

SUBMITTAL INFORMATION

Uni-Flange® Mechanical Joint Restraint (UFR1500-CA-x-RB-I style)

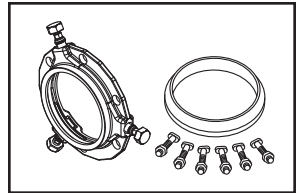

4" - 12" SERIES UFR1500 MECHANICAL JOINT RESTRAINT FOR C900, C909 OR HDPE PACKAGED WITH FLUOROCARBON-COATED ACCESSORIES

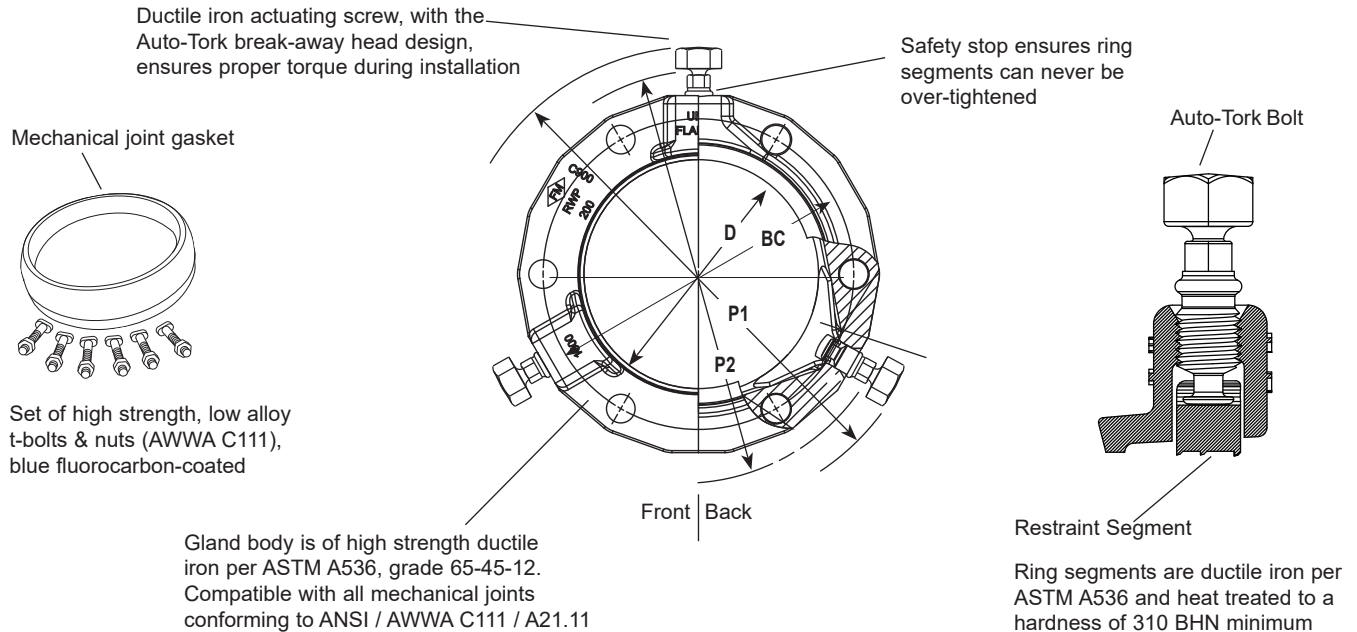

NOM. PIPE SIZE	PIPE O.D. (IN.)	CATALOG NUMBER	NO. OF RESTRAINT SEGMENTS	APPROX. WEIGHT (LBS.)	P1*	P2** APPROX.	BC	D	PRESSURE RATING					✓ SUBMITTED ITEM(S)
									C900			C909		
									DR-14	DR-18	DR-25	PC-165	PC-235	
4"	4.80	UFR1500-CA-4-RB-I	2	12.5	13.00"	9.40"	7.50"	4.90"	305 PSI	235 PSI	165 PSI	165 PSI	235 PSI	
6"	6.90	UFR1500-CA-6-RB-I	3	18.0	15.13"	11.60"	9.50"	7.00"	305 PSI	235 PSI	165 PSI	165 PSI	235 PSI	
8"	9.05	UFR1500-CA-8-RB-I	4	23.0	17.25"	13.75"	11.75"	9.15"	305 PSI	235 PSI	165 PSI	165 PSI	235 PSI	
10"	11.10	UFR1500-CA-10-RB-I	8	33.0	19.38"	16.00"	14.00"	11.20"	305 PSI	235 PSI	165 PSI	165 PSI	235 PSI	
12"	13.20	UFR1500-CA-12-RB-I	8	38.0	21.50"	18.05"	16.25"	13.30"	305 PSI	235 PSI	165 PSI	165 PSI	235 PSI	

*Maximum O.D. of gland on pipe before Auto-Tork heads are removed (as shipped)

**Maximum O.D. of gland on pipe after Auto-Tork heads are removed

Note: Ford recommends the use of a properly sized insert stiffener when using UFR1500 on HDPE

FEATURES

- Full circle contact and support of the pipe wall. The Series 1500 can be used on AWWA C900, AWWA C909 PVCO or HDPE without any point loading.
- Auto-Tork actuating screws with heads specially designed to twist off at the correct installation torque, leaving a hex head for future system maintenance or removal
- Set of high strength, low alloy t-bolts and nuts with blue fluorocarbon-coating (AWWA C111)
- Mechanical joint gasket (AWWA C111)
- Series 1500 eliminates the need to pour expensive and time consuming concrete thrust blocks
- Restraining segments are mechanically retained in pockets
- Gland, screws and segments are black epoxy coated using the e-coat process
- Gland colored red for identification purposes

The Ford Meter Box Company considers the information in this submittal form to be correct at the time of publication. Item and option availability, including specifications, are subject to change without notice. Please verify that your product information is current. Our standard warranty applies.



The Ford Meter Box Company, Inc.
P.O. Box 443, Wabash, Indiana U.S.A. 46992-0443
Phone: 260-563-3171 / Fax: 800-826-3487
Overseas Fax: 260-563-0167
www.fordmeterbox.com



06/24/21

Submitted By: