

FIGURE 661B CAST IRON VALVES



125# FLANGED 200 WOG IBBM GLOBE VALVE

FEATURES

- 200 psi WOG non-shock (-20°F to 150°F)
- 125 psi WSP (125 psi at 450°F)
- Flat faced flanges
- Rising stem OS&Y
- Back seat stop

PRODUCT SPECIFICATIONS

Standards

- Class 125 flanges: ANSI B16.1
- Pressure/temperature rating: MSS SP-85
- Face to face dimensions: ANSI B16.10
- Design and testing: MSS SP-85



OPTIONS & ACCESSORIES

- FNW offers many options, accessories and modifications for their iron body valves which include, but are not limited to: by-passes, packing options, stem extensions, floor stands, switches, and actuation such as pneumatic cylinders or electric operators, gear operators, and chain wheels.

TEMPERATURE/PRESSURE*

Temp (°F)	Pressure (PSI)
-20 to 150	200
200	190
225	180
250	175
275	170
300	165
325	155
350	150
375	145
400	140
425	130
**450	125

**P/T listed is for 2 to 12 inch, 200 WOG ASTM A126 Class B gray iron valves. Temperatures shown are that of the pressure containing parts of the valve and are assumed to be equal to the contained fluid's temperature. Use of a pressure rating at a pressure containing temperature other than the contained fluid's is at the responsibility of the end-user.*

DIMENSIONS (INCHES)

Size	Port	H	L	C	D	D1	T	nxh
2	2.00	11.93	8.00	4.75	6.00	7.00	0.62	4x3/4
2-1/2	2.50	12.83	8.50	5.50	7.00	7.00	0.69	4x3/4
3	3.00	13.62	9.50	6.00	7.50	8.00	0.75	4x3/4
4	4.00	14.57	11.50	7.50	9.00	10.00	0.94	8x3/4
5	5.00	17.71	13.00	8.50	10.00	12.00	0.94	8x3/4
6	6.00	19.69	14.00	9.50	11.00	12.00	1.00	8x3/4
8	8.00	22.68	19.50	11.75	13.50	14.00	1.12	8x3/4
10	10.00	27.00	24.50	14.25	16.00	16.00	1.19	12x1
12	12.00	29.80	27.50	17.00	19.00	18.00	1.25	12x1

FIGURE 661B CAST IRON VALVES



125# FLANGED 200 WOG IBBM GLOBE VALVE

PARTS BREAKDOWN

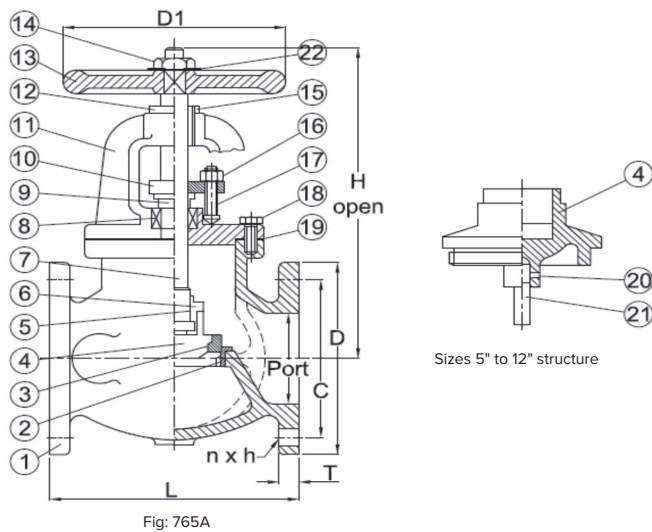

CV & WEIGHT

Size	Cv	Wt. (Lbs)
2	45	36.1
2-1/2	75	48.7
3	110	56.8
4	200	95.0
5	320	138.8
6	475	182.6
8	875	378.3
10	1370	522.5
12	2050	705.0

FIGURE NUMBER MATRIX

FNW	661	Size Code		
		2 = K	4 = P	8 = X
		2-1/2 = L	5 = S	10 = 10
		3 = M	6 = U	12 = 12

PART MATERIALS & QUANTITY

Ref #	Description	Material	Specification	Qty	Notes
1	Body	Cast Iron	ASTM A126-B	1	
2	Body Seat Ring	Cast Bronze	ASTM B62	1	
3	Disc Seat Ring	Cast Bronze	ASTM B62	1	5 - 12
4	Disc Seat Ring	2 - 4 Cast Bronze 5 - 12 Cast Iron	ASTM B62 ASTM A126-B	1	
5	Stop Washer	Brass	ASTM B16	1	
6	Disc Nut	Cast Bronze	ASTM B62	1	
7	Stem	Brass	ASTM B16	1	
8	Packing	Non-Asbestos Packing		3	4 on 6 - 12
9	Gland	Cast Bronze	ASTM B62	1	
10	Gland Flange	Ductile Iron	ASTM A536	1	
11	Bonnet	Cast Iron	ASTM A126-B	1	
12	Yoke Bush	Cast Bronze	ASTM B62	1	
13	Hand Wheel	Cast Iron	ASTM A126-B	1	
14	Nut	Steel	ASTM A307-A	1	
15	Socket Set Screw	Steel	ASTM A307-A	1	
16	Gland Glange Nut	Steel	ASTM A307-A	2	
17	Square Head Bolt	Steel	ASTM A307-A	2	
18	Hex. Head Bolt	Steel	ASTM A307-A	1 Set	
19	Gasket	Non-Asbestos		1	
20	Taper Pin	Steel		1	5 - 12
21	Guide Pin	Brass	ASTM B16	1	5 - 12
22	Washer	Steel	ASTM A307-A	1	