



model 1202S

Wall Mount Hi-Lo ADA Water Cooler

FEATURES & BENEFITS

MODERN INNOVATIVE DESIGN

Modern, innovative design with stainless steel finish gives a sleek look and feel to high-end architectural spaces and lobbies.

UNIVERSAL MOUNTING

Specially designed internal configuration allows for mounting over existing competitors rough-ins.

BUBBLER HEAD

Bubbler features a flexible antimicrobial mouth guard to protect against injury and microorganisms. Anti-rotational design prevents unwanted attempts to remove or rotate

ACTIVATION

Electronic front push bar eight inches wide and operable from any point on the surface activates an electronic solenoid valve.

VANDAL RESISTANT FEATURES

Exceptional vandal resistance features include an anti-rotational bubbler head with an optional stainless steel version, UPC impact tested bowl supports, Torx bit access screws, steel frame, and fasteners hidden from public view.

OPTIONS

Bubbler Head: Model 5716, stainless steel bubbler head for the Haws 1200 series water coolers.

Cane Detection, Floor Mounted: Model SK6, floor mounted cane detection for the Haws Hi-Lo drinking fountains.

For more information, visit www.hawsc.com or call (888) 640-4297.



SPECIFICATIONS

Model 1202S indoor wall-mount ADA Hi-Lo stainless steel water cooler shall include an ASHRAE compliant, hermetically sealed R-134a refrigeration system with adjustable thermostat. Unit features a unique, modern Hi-Lo (dual fountain) design with stainless steel outer shell. The system includes electronic front push bar controlled solenoid valves, and .45 gpm self-regulating, anti-rotational bubbler heads with flexible antimicrobial mouth guards, and instantaneous tankless water cooler for consistent cool water. 115 Volts, 60Hz, rated watts: 350, full load amps: 5. Dimensions: (L x W x H) 18-3/4 x 34-1/16 x 31-3/4"

APPLICATIONS

Great for schools, office buildings, shopping malls, and other indoor environments where there is a demand for a chilled water source. CSA certified to comply with NSF/ANSI 61 and 372, ASME A112.18.1/CSA B125.1, ASME112.19.3/CSA B45.4, UL 399 and CSA C22.2 No. 120. ADA compliant to ICC A117.1, CSA B651, DOJ's 2010 ADA Standards for Accessible Design when properly installed. ASHRAE 18 compliant chilling capacity. Electric water coolers are not recommended or designed for outdoor applications or enclosed pool areas (chlorine), and failure to heed these conditions may void warranty. 5 Year Limited Warranty on the refrigeration system of the unit. Electrical components and water system are warranted for 12 months from date of installation. Warranty pertains to drinking water applications only.



NOTES:

1. HOLD PLUMBING & ELECTRICAL DIMENSIONS $\pm 1/4"$ (6.4mm). HOLD MOUNTING DIMENSIONS $\pm 1/8"$ [± 3.2 MM].
2. ADHERING TO PROVIDED INSTALLATION HEIGHT DIMENSIONS WILL ALLOW A SINGLE WATER COOLER (OR THE LOW WATER COOLER IN A HI-LO INSTALLATION), AND THE BOTTLE FILLER (IF APPLICABLE) TO BE INSTALLED AT ADULT ADA HEIGHT. FOR INSTALLATION HEIGHTS OTHER THAN SHOWN, DIMENSIONS MARKED (*) MUST BE ADJUSTED ACCORDINGLY. WHEN INSTALLING THIS UNIT, LOCAL, STATE, OR FEDERAL CODES SHOULD BE ADHERED TO.

TYPICAL SINGLE (OR LOW) UNIT INSTALLATION

(REFRIGERATION COMPONENTS HIDDEN FOR CLARITY)

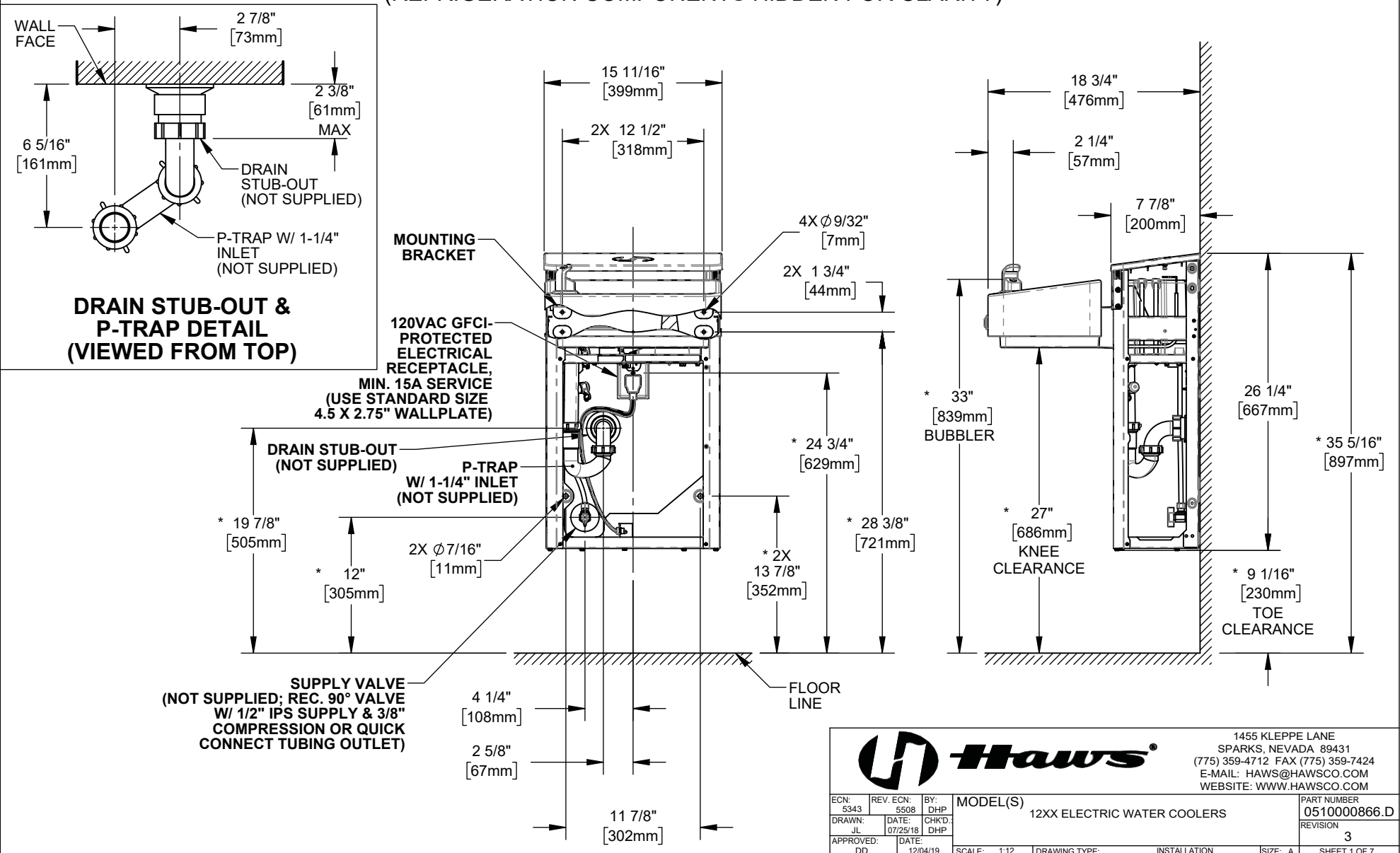

1455 KLEPPE LANE
SPARKS, NEVADA 89431
(775) 359-4712 FAX (775) 359-7424
E-MAIL: HAWS@HAWSO.COM
WEBSITE: WWW.HAWSO.COM

ECN: 5343	REV. ECN: 5508	BY: DHP	MODEL(S)	PART NUMBER
DRAWN: JL	DATE: 07/25/18	CHKD: DHP	12XX ELECTRIC WATER COOLERS	0510000866.D
APPROVED: DD	DATE: 12/04/19			REVISION
				3
SCALE: 1:12 DRAWING TYPE: INSTALLATION			SIZE: A	SHEET 1 OF 7

TYPICAL HI-LO UNIT INSTALLATION

(REFRIGERATION COMPONENTS HIDDEN FOR CLARITY)

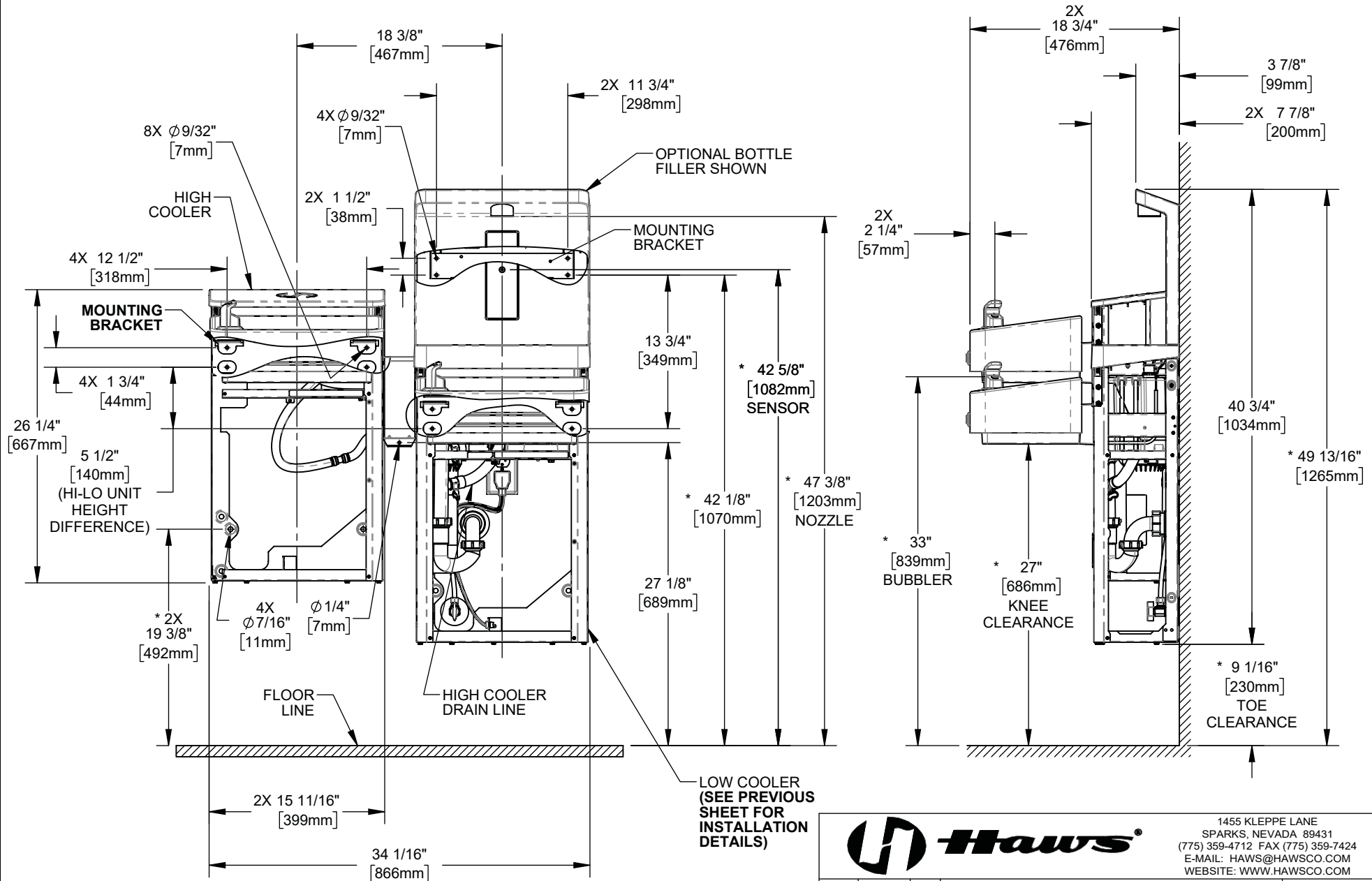

1455 KLEPPE LANE
SPARKS, NEVADA 89431
(775) 359-4712 FAX (775) 359-7424
E-MAIL: HAWS@HAWS.CO.COM
WEBSITE: WWW.HAWS.CO.COM

ECN: 5343	REV. ECN: 5508	BY: DHP	MODEL(S)	PART NUMBER
DRAWN: JL	DATE: 07/25/18	CHKD: DHP	12XX ELECTRIC WATER COOLERS	0510000866.D
APPROVED: DD	DATE: 12/04/19			REVISION
				3
SCALE: 1:12			DRAWING TYPE: INSTALLATION	SIZE: A
				SHEET 2 OF 7

BOTTLE FILLER INSTALLATION DETAILS

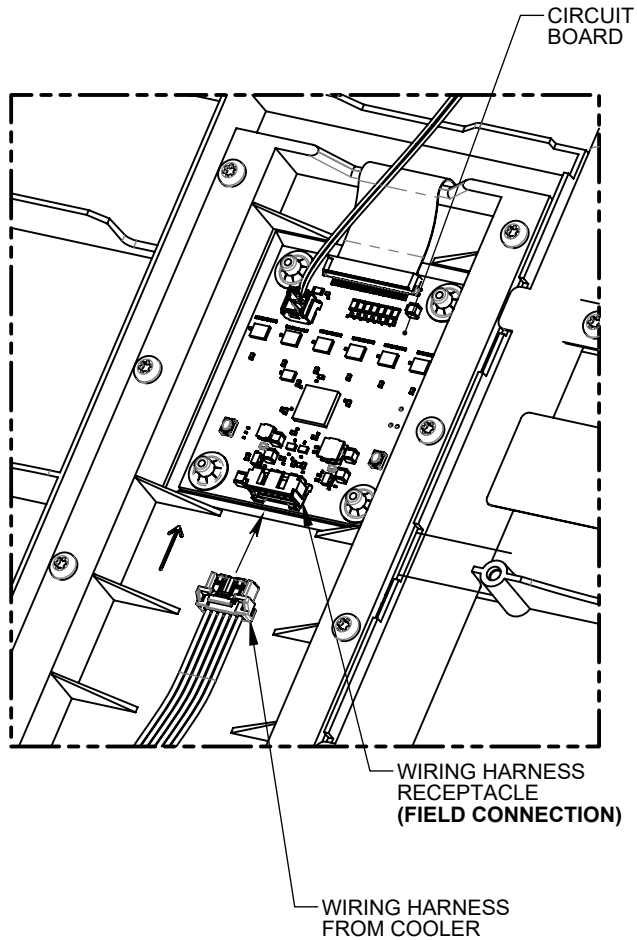

**WIRING HARNESS CONNECTION
(REAR OF BOTTLE FILLER)**

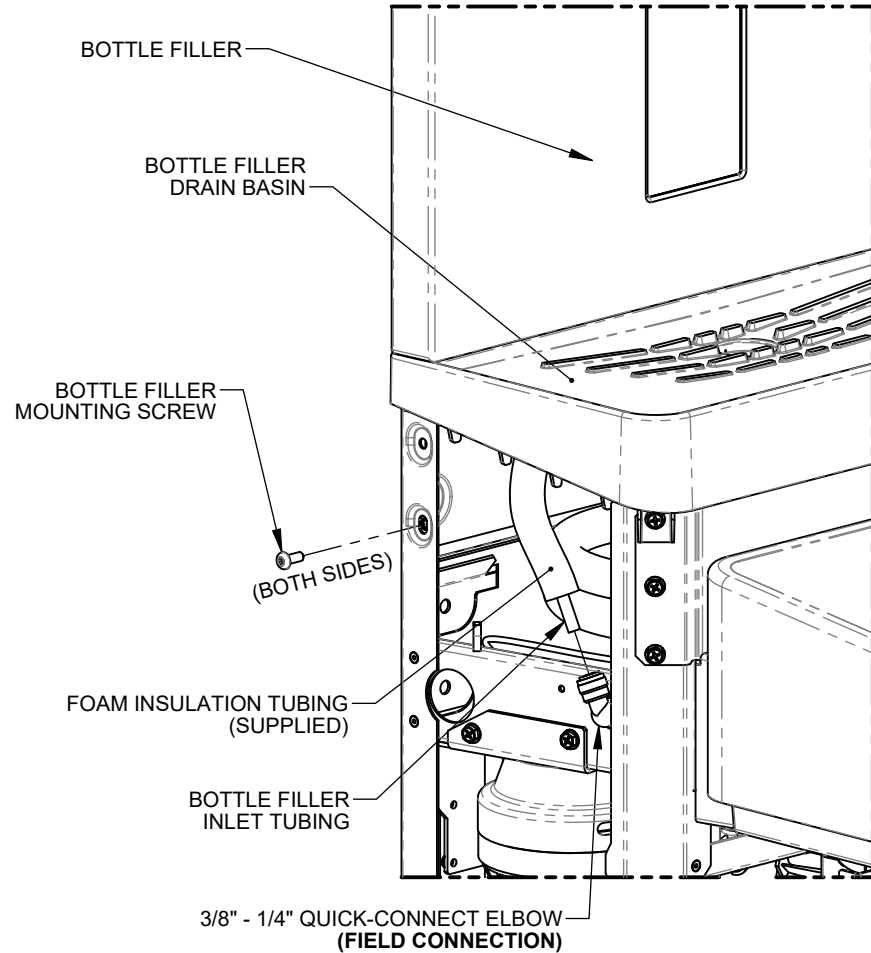

**BOTTLE FILLER MOUNTING &
TUBING CONNECTION**

		1455 KLEPPE LANE SPARKS, NEVADA 89431 (775) 359-4712 FAX (775) 359-7424 E-MAIL: HAWS@HAWSCO.COM WEBSITE: WWW.HAWSCO.COM	
		ECN: 5343 DRAWN: JL APPROVED: DD	REV. ECN: 5508 DATE: 07/25/19 DATE: 12/04/19
PART NUMBER 0510000866.D			REVISION 3
SCALE: 1:12 DRAWING TYPE: INSTALLATION SIZE: A		SHEET 3 OF 7	

HIGH EWC INSTALLATION DETAILS

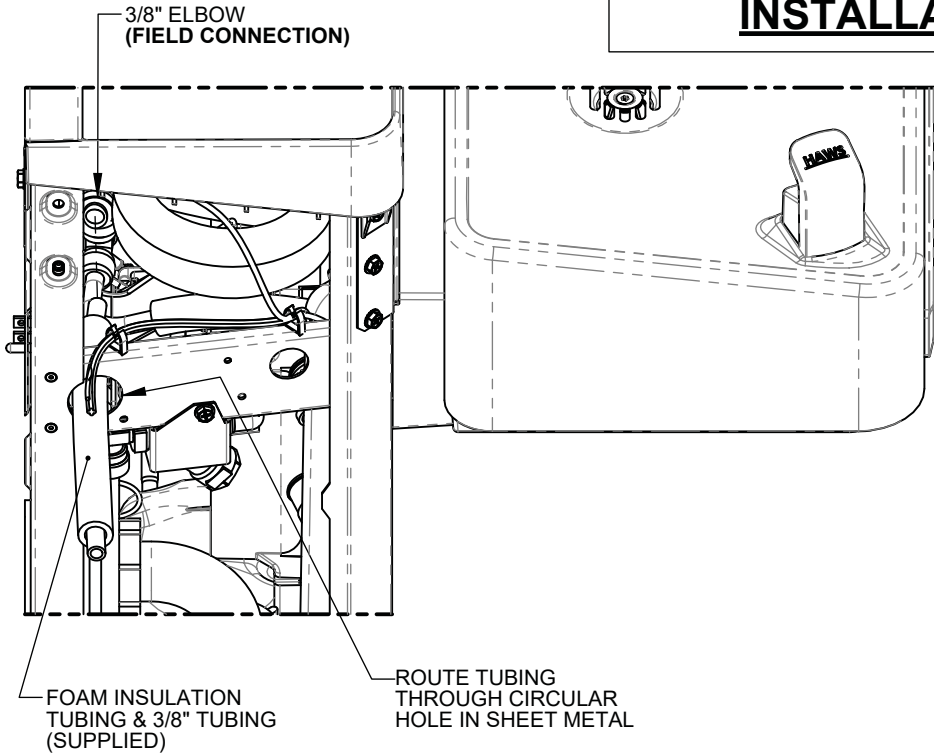

**HIGH EWC TUBING CONNECTION
(ON LOW COOLER)**

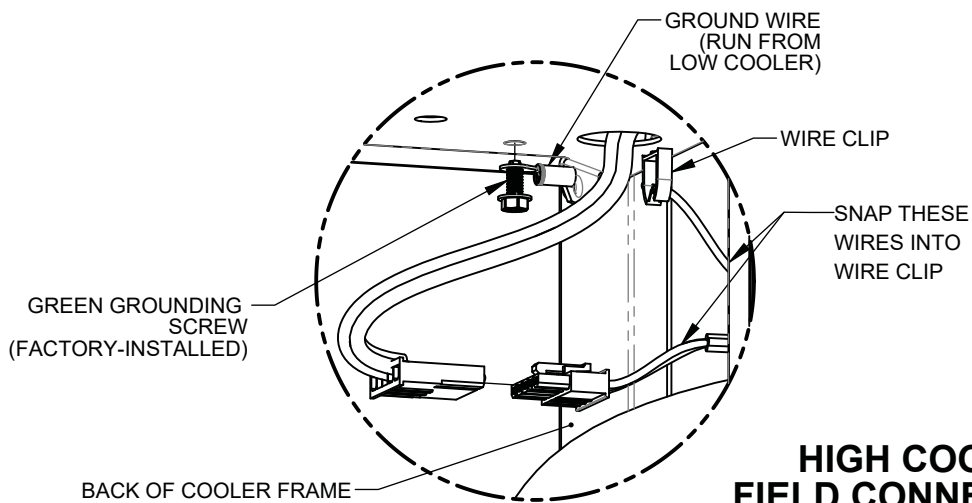
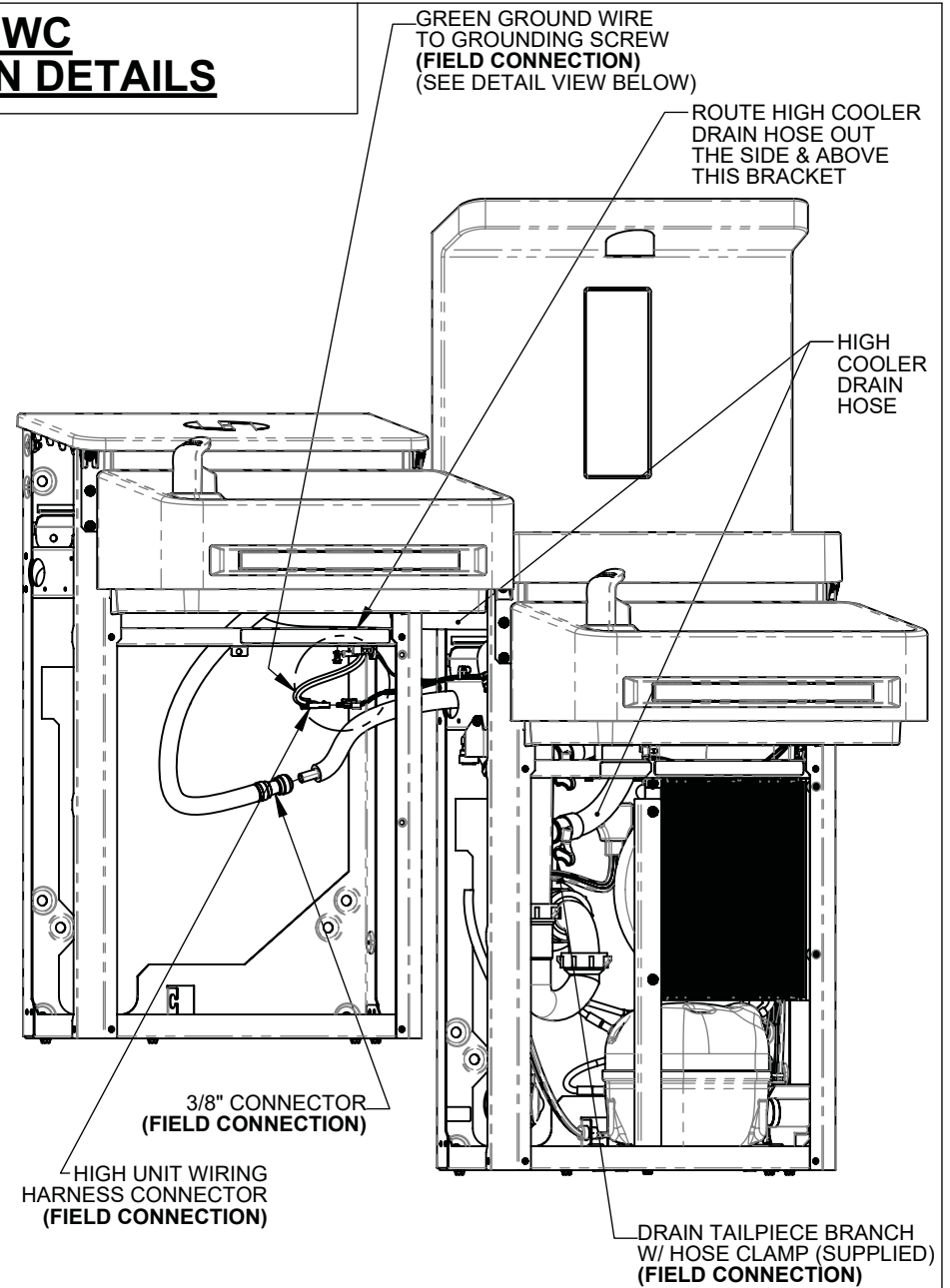

**HIGH COOLER
FIELD CONNECTIONS**

1455 KLEPPE LANE
SPARKS, NEVADA 89431
(775) 359-4712 FAX (775) 359-7424
E-MAIL: HAWS@HAWSCO.COM
WEBSITE: WWW.HAWSCO.COM

ECN: 5343	REV. ECN: 5508	BY: DHP	MODEL(S)	PART NUMBER
DRAWN: JL	DATE: 07/25/18	CHKD: DHP	12XX ELECTRIC WATER COOLERS	0510000866.D
APPROVED: DD	DATE: 12/04/19			REVISION
		SCALE: 1:24	DRAWING TYPE: INSTALLATION	3
			SIZE: A	SHEET 4 OF 7

RETROFIT INSTALLATION DETAILS

3 RETROFIT TABLE

MANUFACTURER	MODEL
HAWS	ALL MODELS STARTING WITH HWUACP
ELKAY/HALSEY TAYLOR	- ALL MODELS STARTING WITH EB, EI, EMA, EN, EZ, HAC HVR, LI, LMA, LZ, TB, & TI - SINGLE COOLER MODELS STARTING WITH VRC & LVR
OASIS	ALL VERSACOOLER II MODELS
SUNROC	ALL MODELS STARTING WITH ADA A171, A171.8, & A172.8UBL MODELS
MURDOCK	NOTE: THE WATER STOP VALVE MUST BE RELOCATED TO RETROFIT A FILTERED 12XX COOLER

LOW COOLER BRACKET HEIGHT		
ADULT STANDING	ADULT ADA	CHILD ADA
33 7/8"	28 3/8"	25 3/8"

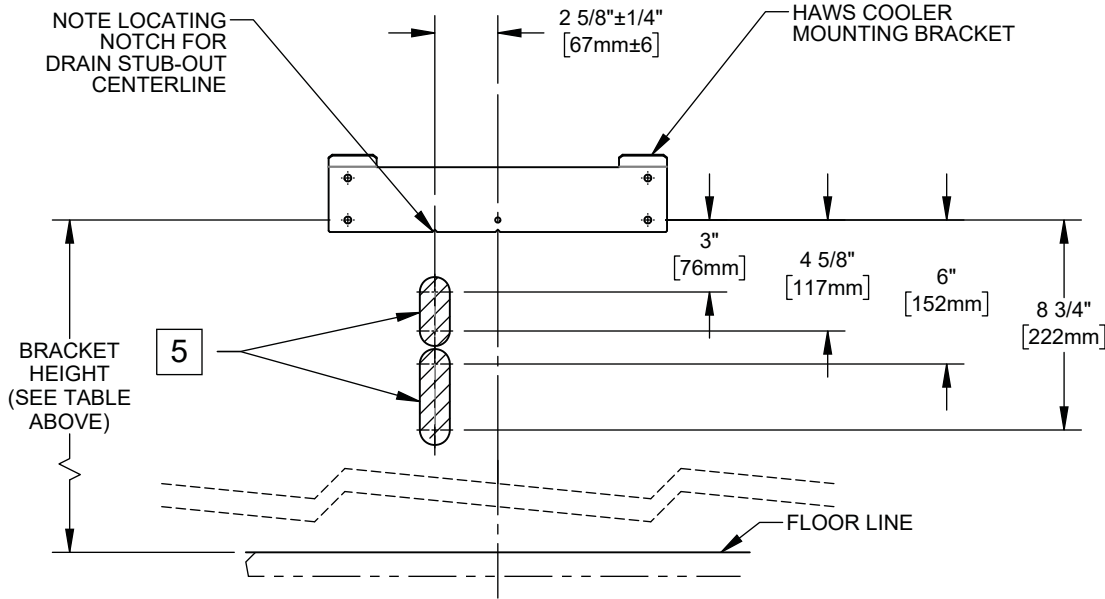

PERMISSIBLE LOCATIONS FOR DRAIN STUB-OUT

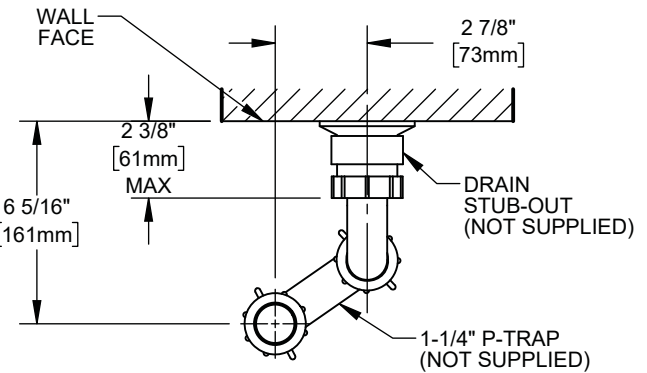

6 DRAIN STUB-OUT/P-TRAP DETAIL (VIEWED FROM TOP)

NOTES:

- 3 THE 12XX COOLER SERIES IS ABLE TO RETROFIT IN PLACE OF A NUMBER OF COMPETITOR MODELS. SEE RETROFIT TABLE ABOVE FOR PARTIAL LIST OF COOLERS ABLE TO BE REPLACED BY THIS ONE.
THE FOLLOWING DISCLAIMERS APPLY:
 - THE 12XX COOLER CENTERLINE MAY NOT MATCH THE OLD COOLER'S CENTERLINE, SINCE THE 12XX COOLER DRAIN MUST BE 2 5/8" OFF OF CENTER. THIS MAY AFFECT ADA COMPLIANCE.
 - FOR HI-LO COOLER RETROFITS, EXISTING RIGHT-SIDE COOLER MUST BE THE LOW COOLER. DRAIN, WATER, AND ELECTRIC SERVICES MUST BE POSITIONED BEHIND RIGHT-SIDE UNIT.
 - THERE MUST BE WALL BLOCKING OR OTHER STRUCTURAL MATERIAL BEHIND HAWS MOUNTING HOLES.
 - VERIFY THAT DRAIN, ELECTRIC, & WATER SERVICES ARE LOCATED WITHIN BOUNDARIES SPECIFIED ON THIS SHEET AND THE NEXT. SOME RETROFITS MAY REQUIRE THE ELECTRIC OUTLET TO BE MOVED.
- 4 THE P-TRAP IS NOT SUPPLIED. THE VERTICAL DIMENSIONS GIVEN ARE BASED UPON INSTALLATION USING OF A KEENEY 200W P-TRAP, AND SHOULD THEREFORE BE REGARDED AS REFERENCE-ONLY.
- 5 THE CENTERLINE OF THE DRAIN STUB-OUT MUST BE BETWEEN 3" [76mm] & 4-5/8" [118mm] OR BETWEEN 6" [152mm] & 8-3/4" [229mm] BELOW THE LOWERMOST EWC MOUNTING BRACKET HOLES IN ORDER FOR THE P-TRAP TO AFFIX PROPERLY TO THE DRAIN TAILPIECE.
 - DEPENDING ON STUB-OUT HEIGHT, SOME TRIMMING OF THE TAILPIECE WILL BE REQUIRED.
 - MOUNTING THE STUB-OUT IN THE HIGHER RANGE WILL REQUIRE TRIMMING THE TAILPIECE ABOVE THE LOWER DRAIN HOSE BRANCH. **IN THIS INSTANCE, THEREFORE, A HI-LO COOLER CANNOT BE INSTALLED.**
- 6 WHATEVER P-TRAP AND STUB-OUT PLUMBING ARE USED, CARE SHOULD BE TAKEN TO ENSURE THAT THE P-TRAP CAN SEAL TO THE STUB-OUT PROPERLY AND STILL ALIGN TO THE DRAIN TAILPIECE (LOCATED AT THE GIVEN DIMENSIONS).

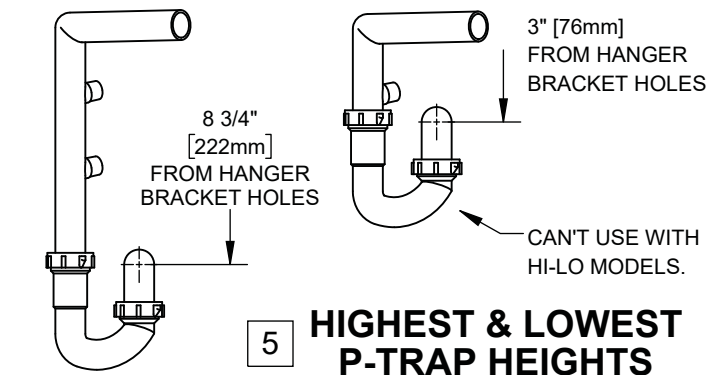

5 HIGHEST & LOWEST P-TRAP HEIGHTS



1455 KLEPPE LANE
SPARKS, NEVADA 89431
(775) 359-4712 FAX (775) 359-7424
E-MAIL: HAWS@HAWS.CO.COM
WEBSITE: WWW.HAWS.CO.COM

ECN: 5343	REV. ECN: 5508	BY: DHP	MODEL(S): 12XX ELECTRIC WATER COOLERS	PART NUMBER: 0510000866.D
DRAWN: JL	DATE: 07/25/18	CHKD: DHP		REVISION: 3
APPROVED: DD	DATE: 12/04/19	SCALE: 1:8	DRAWING TYPE: INSTALLATION	SIZE: A SHEET 5 OF 7

RETROFIT INSTALLATION DETAILS

WATER SUPPLY VALVE IS PERMISSIBLE IN THIS AREA FOR BOTH FILTER AND UNFILTERED MODELS. VALVE MAY PROTRUDE 2 3/4" MAXIMUM FOR WALL. LARGE ESCUTCHEONS MAY NOT BE FEASIBLE, DEPENDING ON VALVE LOCATION.

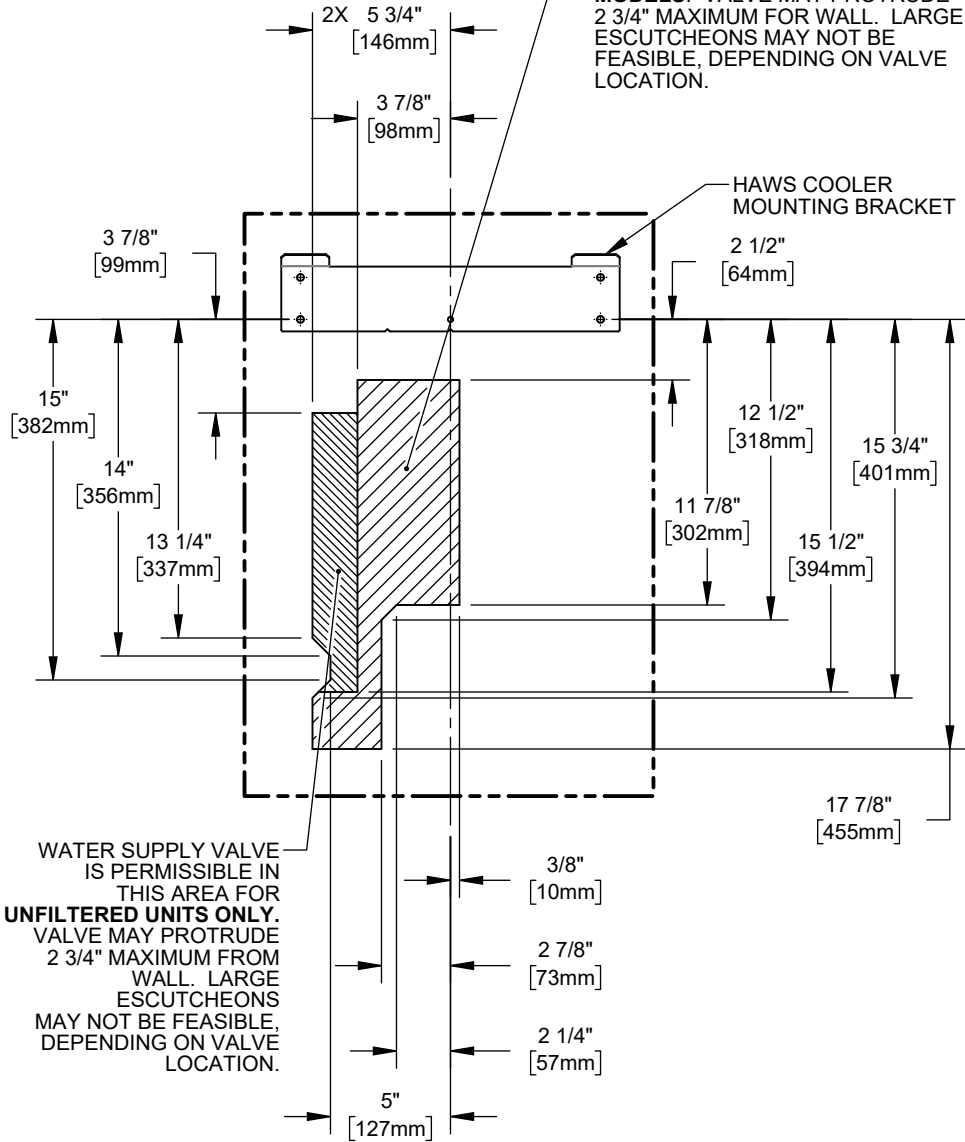

PERMISSIBLE WATER SUPPLY LOCATIONS

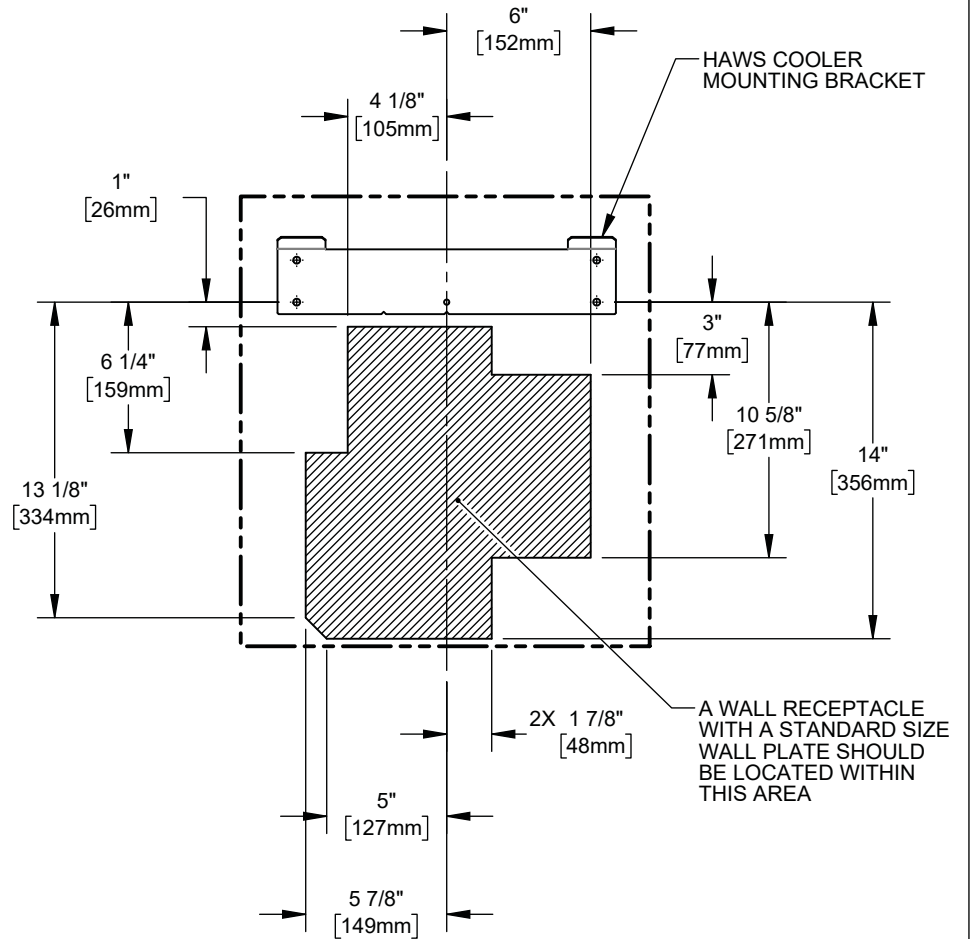

PERMISSIBLE ELECTRICAL RECEPTACLE LOCATIONS

		1455 KLEPPE LANE SPARKS, NEVADA 89431 (775) 359-4712 FAX (775) 359-7424 E-MAIL: HAWS@HAWSCO.COM WEBSITE: WWW.HAWSCO.COM	
		ECN: 5343 REV. ECN: 5508 BY: DHP MODEL(S) DRAWN: JL DATE: 07/25/19 CHKD: DHP 12XX ELECTRIC WATER COOLERS	PART NUMBER 0510000866.D REVISION 3
APPROVED: DD DATE: 12/04/19 SCALE: 1:8 DRAWING TYPE: INSTALLATION SIZE: A SHEET 6 OF 7			

MAINTENANCE

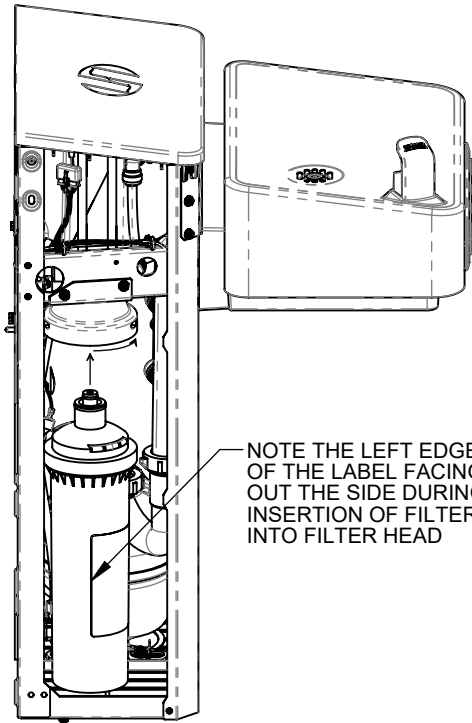

NOTE THE LEFT EDGE OF THE LABEL FACING OUT THE SIDE DURING INSERTION OF FILTER INTO FILTER HEAD

FILTER REPLACEMENT

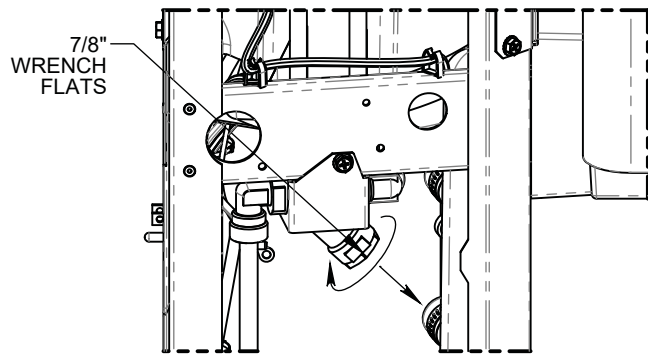

7/8" WRENCH FLATS

Y-STRAINER CLEANING



1455 KLEPPE LANE
 SPARKS, NEVADA 89431
 (775) 359-4712 FAX (775) 359-7424
 E-MAIL: HAWS@HAWSO.COM
 WEBSITE: WWW.HAWSO.COM

ECN: 5343	REV. ECN: 5508	BY: DHP	MODEL(S) 12XX ELECTRIC WATER COOLERS	PART NUMBER 0510000866.D
DRAWN: JL	DATE: 07/25/18	CHKD: DHP		REVISION 3
APPROVED: DD	DATE: 12/04/19	SCALE: 1:8	DRAWING TYPE: INSTALLATION	SIZE: A
				SHEET 7 OF 7