



# Operating Instructions

## Models 46521, 465210, 46523, 465230 465250, 465260

### Wheel Kits 34562 and 34654

<b>46521</b>	
DIMENSIONS:	28" (71cm) L x 20" (51cm) W x 19.5" (49.5cm) H
WEIGHT:	111 lbs. 50.5 kg
PUMP:	Triple Diaphragm: Positive Displacement Ports: 1" inlet ; 3/4" NPT outlet Capacity: 10gpm, 38lpm Pressure: 0-500psi Operating Speed: 550rpm Lubrication: Pump 30W Non-detergent Gear 80/90W Gear Oil Shaft Size: 1" Female
ENGINE:	6.5hp Briggs & Stratton Intek Pro, 4 cycle, gasoline
CONTROL:	0 – 500psi adjustable pressure relief valve
GAUGE:	Glycerin filled, 0 – 600psi, 0-42kg
DISCHARGE HOSE:	3/4" x 10' (3m) 1000psi rated
INLET HOSE:	3/4" x 10' (3m) with strainer

<b>465210</b>	
DIMENSIONS:	28" (71cm) L x 24" (51cm) W x 35" (49.5cm) H
WEIGHT:	111 lbs. 50.5 kg
PUMP:	Triple Diaphragm: Positive Displacement Ports: 1" inlet ; 3/4" NPT outlet Capacity: 10gpm, 38lpm Pressure: 0-500psi Operating Speed: 550rpm Lubrication: Pump 30W Non-detergent Gear 80/90W Gear Oil Shaft Size: 1" Female
ENGINE:	Honda 5.5hp, 4 cycle, gasoline
CONTROL:	0 – 500psi adjustable pressure relief
GAUGE:	Glycerin filled, 0 – 600psi, 0-42kg
DISCHARGE HOSE:	3/4" x 10' (3m) 1000psi rated
INLET HOSE:	3/4" x 10' (3m) with strainer



# Operating Instructions

## Models 46521, 465210, 46523, 465230 465250, 465260

### Wheel Kits 34562 and 34564

<b>46523</b>	
DIMENSIONS:	23" (57cm) L x 20" (51cm) W x 19.5" (50cm) H
WEIGHT:	105 lbs. 48 kg
PUMP:	Triple Diaphragm: Positive Displacement Ports: 3/4" inlet ; 1/2" NPT outlet Capacity: 10gpm, 38lpm Pressure: 0-500psi Operating Speed: 550rpm (max) 400rpm (min) Lubrication: Pump 30W Non-Detergent Gear 80/90W Gear Oil Shaft Size: 1" Female
ENGINE:	6.5hp Briggs & Stratton Intek Pro, 4 cycle, gasoline
CONTROL:	50 – 500psi adjustable pressure relief valve
GAUGE:	Glycerin filled, 0 – 1000psi, 0-69bar
DISCHARGE HOSE:	1/2" x 10' (3m) 2000psi rated
INLET HOSE:	3/4" x 10' (3m) with strainer

<b>465230</b>	
DIMENSIONS:	23" (57cm) L x 20" (51cm) W x 19.5" (50cm) H
WEIGHT:	105 lbs. 48 kg
PUMP:	Triple Diaphragm: Positive Displacement Ports: 3/4" inlet ; 1/2" NPT outlet Capacity: 10gpm, 38lpm Pressure: 0-500psi Operating Speed: 550rpm (max) 400rpm (min) Lubrication: Pump 30W Non-Detergent Gear 80/90W Gear Oil Shaft Size: 1" Female
ENGINE:	Honda 5.5hp, 4 cycle, gasoline
CONTROL:	50 – 500psi adjustable pressure relief
GAUGE:	Glycerin filled, 0 – 1000psi, 0-69bar
DISCHARGE HOSE:	1/2" x 10' (3m) 2000psi rated
INLET HOSE:	3/4" x 10' (3m) with strainer



# Operating Instructions

## Models 46521, 465210, 46523, 465230 465250, 465260

### Wheel Kits 34562 and 34564

<b>465250</b>	With 2 wheel kit and tank
DIMENSIONS:	40" (57cm) L x 20" (51cm) W x 39" (50cm) H
WEIGHT:	<b>200 lbs. 91 kg</b>
PUMP:	Triple Diaphragm: Positive Displacement Ports: 3/4" inlet ; 1/2" NPT outlet Capacity: 10gpm, 38lpm Pressure: 0-500psi Operating Speed: 550rpm (max) 400rpm (min) Lubrication: Pump 30W Non-Detergent Gear 80/90W Gear Oil Shaft Size: 1" Female
ENGINE:	6.5hp Briggs & Stratton Intek Pro, 4 cycle, gasoline
CONTROL:	50 – 500psi adjustable pressure relief valve
GAUGE:	Glycerin filled, 0 – 1000psi, 0-69bar
DISCHARGE HOSE:	1/2" x 10' (3m) 2000psi rated
INLET HOSE:	3/4" x 10' (3m) with strainer

<b>465260</b>	With 4 wheel kit and tank
DIMENSIONS:	38" (57cm) L x 20" (51cm) W x 39" (50cm) H
WEIGHT:	<b>216 lbs. 98 kg</b>
PUMP:	Triple Diaphragm: Positive Displacement Ports: 3/4" inlet ; 1/2" NPT outlet Capacity: 10gpm, 38lpm Pressure: 0-500psi Operating Speed: 550rpm (max) 400rpm (min) Lubrication: Pump 30W Non-Detergent Gear 80/90W Gear Oil Shaft Size: 1" Female
ENGINE:	Honda 5.5hp, 4 cycle, gasoline
CONTROL:	50 – 500psi adjustable pressure relief
GAUGE:	Glycerin filled, 0 – 1000psi, 0-69bar
DISCHARGE HOSE:	1/2" x 10' (3m) 2000psi rated
INLET HOSE:	3/4" x 10' (3m) with strainer



# Operating Instructions

## Models 46521, 465210, 46523, 465230 465250, 465260

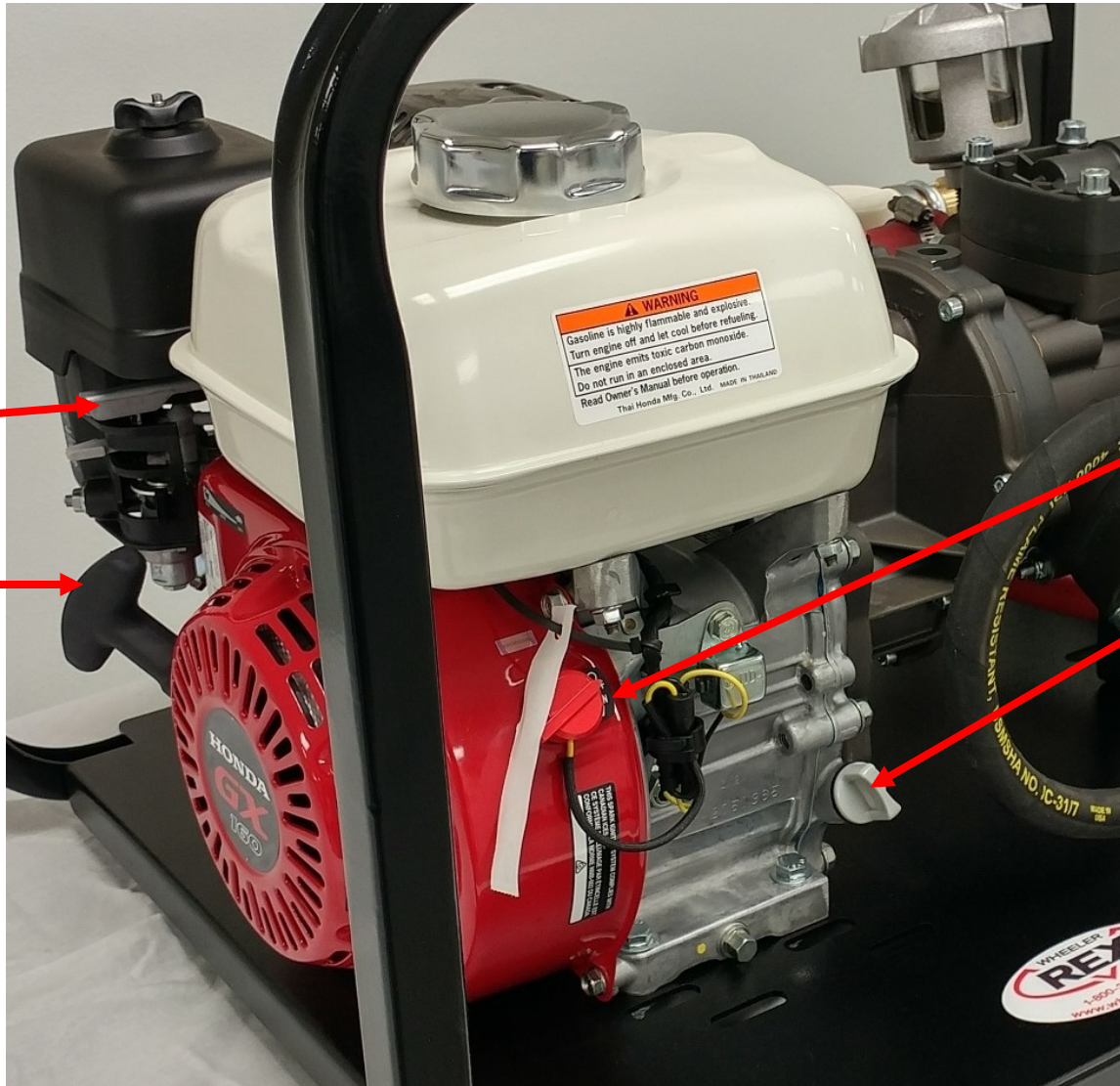

### 465210 / 465230

A	Engine Controls (throttle, choke, gas ON/OFF)
B	Pull Start
C	Power Switch ON/OFF
D	Dipstick / Engine oil fill



# Operating Instructions

## Models 46521, 465210, 46523, 465230 465250, 465260

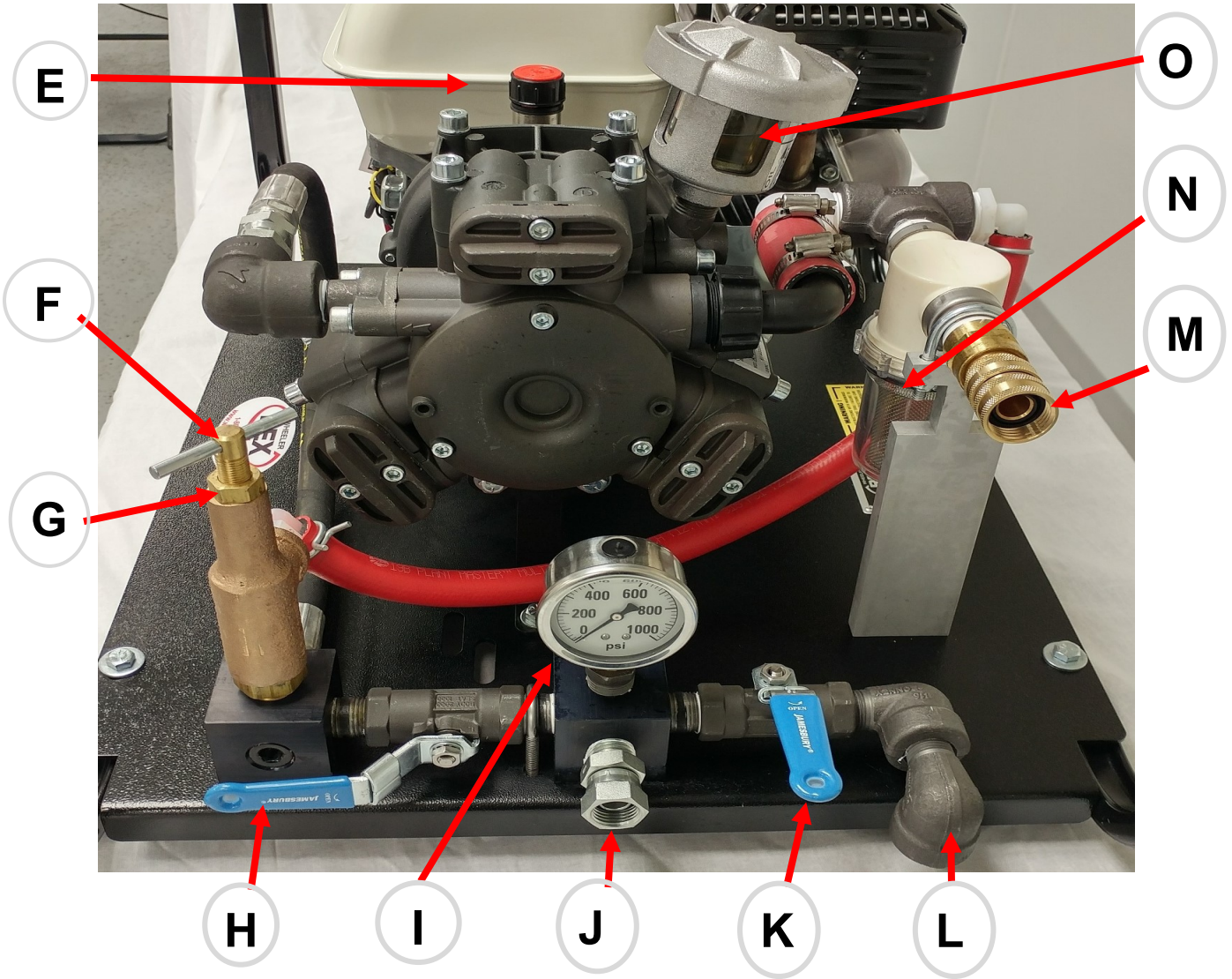

E	Pump gear lube vent cap / fill	L	Dump port
F	Relief valve adjustment	M	Inlet connection
G	Relief valve jam nut	N	Strainer bowl
H	Isolation valve	O	Pump diaphragm oil reservoir
I	Gauge		
J	Outlet connection		
K	Dump Valve		



# Operating Instructions

## Models 46521, 465210, 46523, 465230 465250, 465260

### Gravity Feed: (Preferred Method)

This method requires a tank with a water outlet at the bottom. The water tank's outlet should be level with or above the level of the water inlet connection on the pump. This allows water to flow naturally into the test pump. Connecting a pressure fed water line is harmful to the diaphragms in the pump.

1. Fill the water line (or test vessel) to be tested prior to pump connection.
2. Connect water supply hose to the garden hose inlet connection (M) on the pump.
3. Open valve and turn water supply on.
4. Purge the pump and pressure hose of all air.
5. Connect output (pressure) hose connection (J) between pump and water line (or vessel) being tested.
6. Turn pump on.
7. Purge water line (or vessel) of all air at the highest point of the system.
8. Bring water line (or vessel) to pressure. Watch the gauge (I) while pumping. When the desired pressure is achieved, turn the isolation valve (H) to the "off" position. The engine can now be turned off. If pressure drops, there is a leak in the line.



### Siphon Meth-

*Use a clean water source*

1. Fill the water line to be tested.
2. Fill the intake hose with water, then quickly place the hose into a bucket and turn pump on. (Unit is self-priming once primed). Continue to run pump until you see the water coming out of the outlet hose, with little or no air mixed with it.
3. Connect the output hose to the water line. Continue on with steps 6 through 8 in Gravity Feed Method.

od



# Operating Instructions

## Models 46521, 465210, 46523, 465230 465250, 465260

### Pre-Setting Your Pump

*Your pump can be pre-set to a specific pressure easily by adjusting the pressure relief valve.*

1. Loosen the jam nut (G) on pressure relief valve. Then unscrew (counterclockwise direction) the pressure relief valve knob (F) a few turns . Be sure not to unscrew the knob too far as the knob and nut can easily be lost.
2. Add a ball valve (not supplied with pump) to the end of the high pressure hose.
3. Follow steps 2 through 4 from the 'Gravity Feed Method'.
4. As water is flowing out of the high pressure hose, turn the ball valve to the off position.
5. Slowly start turning pressure relief valve knob (F) in the clockwise direction by  $\frac{1}{4}$  turn increments, until you reach the desired pressure. Tighten jam nut (G) to hold at this desired pressure.
6. Your test pump is now pre-set. This eliminates over-pressurizing the water line (or the vessel).

**WARNING** This product can expose you to chemicals lead and lead compounds, which are known to the State of California to cause cancer and birth defects or other reproductive harm. For more information go to [www.P65Warnings.ca.gov](http://www.P65Warnings.ca.gov).





# Operating Instructions

## Models 46521, 465210, 46523, 465230 465250, 465260

### Troubleshooting Your Pump

Test pressure not being reached:

- Possible air in line (or vessel)
  - ◊ Air needs to be purged from system.
  - ◊ Remove pump from system and follow steps 1 through 6 of the "Pre-setting Your Pump" section.
  - ◊ If using the Siphon Method and not getting pressure, try the "Gravity Feed Method" to ensure water is getting into the pump.
  - ◊ Check strainer (F) O-Ring for cracks.
- Oil Reservoir is milky in color
  - ◊ Diaphragm is cracked, causing water to mix with oil. Diaphragm needs replaced.
- Pressure relief valve not adjusted properly.
  - ◊ Turn relief valve counterclockwise and watch gauge (C) for change in pressure.

### Pump Maintenance

- Pump 50/50 antifreeze/water solution through pump after each use to avoid freezing and to lubricate pump.
- Check strainer (F) O-Ring for cracks prior to each use.
- Check and change engine oil per manufacturers specifications.
- Gear reduction Gear Lube. Check and change per manufacturers specifications.
- Pump repair kit (Wheeler Rex PN 36345)
- Suction Hose (Wheeler Rex PN 34550)
- Pump Oil Reservoir - Check and change per manufacturers specs. Use 30W Non-detergent oil

### Dump Valve

Dump valve is designed to dump off pressure when the test is complete..

**CAUTION !!!**  
**This pump is designed for water only!!**

The pump is equipped with an adjustable pressure relief valve (A), which helps protect the system from being over pressurized. It can be preset by plugging the end of the hose. Turn the adjusting knob clockwise to increase pressure and counterclockwise to decrease.



NOTE: 276140 HONDA ENGINE,  
USED ON 465210 ASSEMBLY

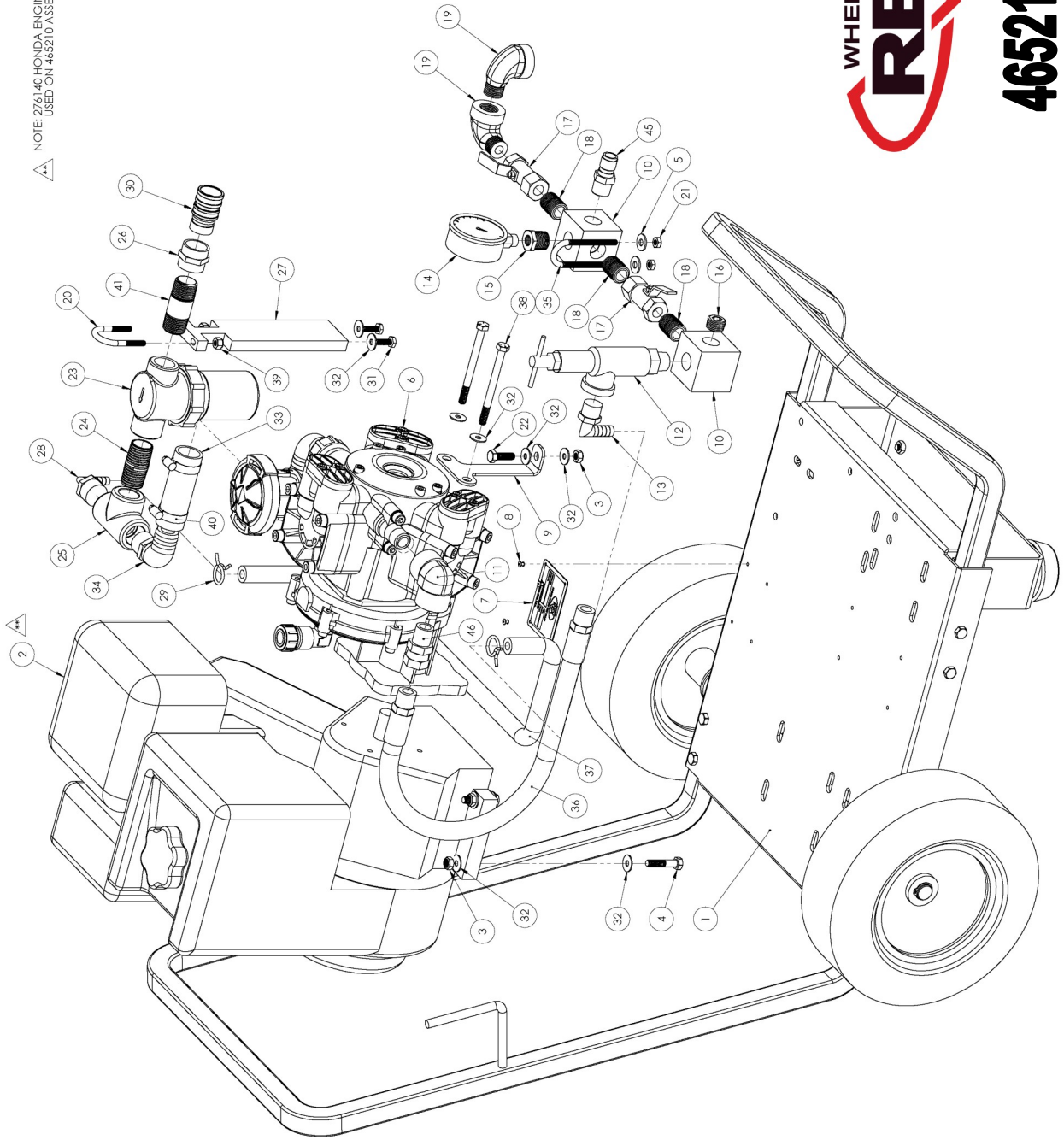

# 46521 Parts

Item	Part No	Description	46521 / 456210	Qty
1	700136	PUMP CART		1
2	275684	6.5 HP BRIGGS & STRATTON ENGINE		1
3	275857	5/16-18 HEX NYLON INSERT LOCKNUTS		7
4	275638	5/16 x 1 1/2" HEX HEAD CAP SCREW		4
5	275685	5/16" FLAT WASHER		2
6	277303	COMET PUMP ASSEMBLY		1
7	220874	NAME PLATE		1
8	275543	POP RIVET, STAR 4-2AAD		4
9	701542	PUMP BRACE (COMET)		1
10	701543	MANIFOLD BLOCK (COMET)		2
11	275697	1/2" 3000LB FS SCRD 90 ELL		1
12	276341	RELIEF VALVE		1
13	277302	1/2" MNPT x 1/2 HB 90 ELBOW		1
14	275788	GAGE 0-1000 PSI		1
15	275670	1/2 x 1/4 FS SCRD HX BUSH		1
16	275368	HEX SOCKET 1/2" NPT PIPE PLUG		1
17	277170	1/2" VALVE		2
18	275669	1/2 x 1 1/2" PIPE NIPPLE		3
19	275666	1/2" FS SCRD STREET ELL		2
20	277220	U-BOLT		1
21	729	1/4-20 THIN ESNA NUT		2
22	1020	5/16-18 x 1" HEX HEAD CAP SCREW		1
23	275932	STRAINER, HYPRO 3350-0040P		1
24	276102	3/4" BRASS CLOSE NIPPLE		1
25	275644	3/4" TEE		1
26	275874	3/4" FH x 3/4" FP ADAPTER		1
27	701544	INLET BRACE		1
28	276184	3/4 NPTx 1/2 90 deg. HOSE BARB		1
29	276185	HOSE CLAMP		2
30	276099	3/4" HOSE QUICK DISCONNECT		1
31	560081	1/4-20 x 3/4" HHCS		2
32	276540	1/4" FLAT WASHER		16
33	701547	CONNECTION HOSE		1
34	277304	3/4 MP x 1" MH 90 DEG HOSE BARB		1
35	277200	SMALL U-BOLT		1
36	700641	HIGH PRESSURE HOSE 22"		1
37	701546	BY-PASS HOSE		1
38	277305	5/16" x 3 3/4" LONG HHCS		2
39	275426	1/4-20 ESNA STOP NUT		2
40	275335	HOSE CLAMP		2
41	277322	3/4" x 2 1/2" LONG BRASS NIPPLE		1
42	277181	WARNING TAG ***NOT SHOWN***		1
43	34550	SUCTION HOSE ASSEMBLY *SHOWN*		1
44	220577	PRESSURE HOSE ***NOT SHOWN***		1
45	276986	1/2" M NPT x M QD		1
46	275689	1/2 NPT x 1/2 SWIVEL ADAPTER		1

**WHEELER**  
**REX**  
**46523 Parts**

NOTE: 276140 HONDA ENGINE  
 USED ON 465200 ASSEMBLY

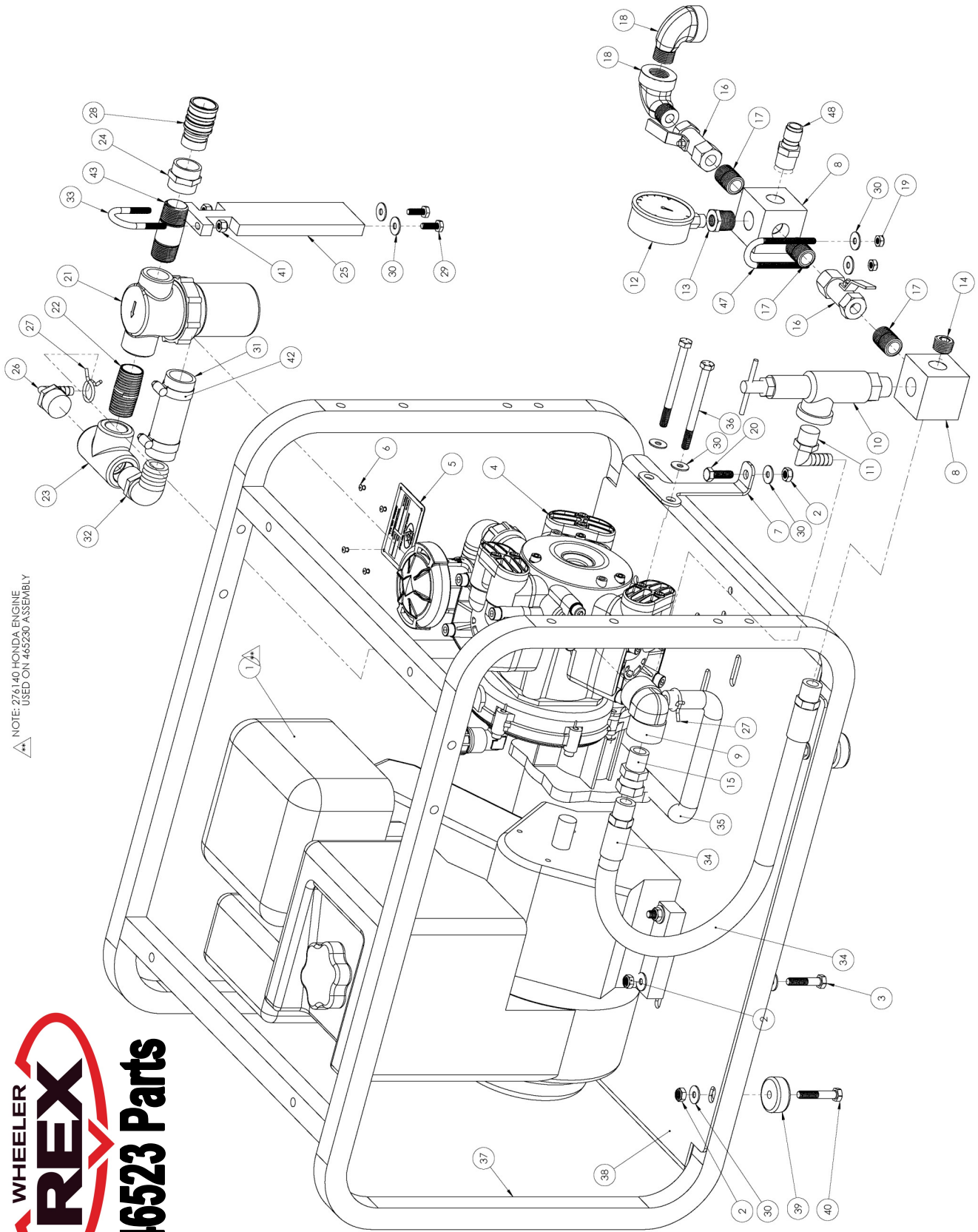

Item	Part No	Description	46523 / 465230	Qty
1	275684	6.5 HP BRIGGS & STRATTON ENGINE		1
2	275857	5/16-18 HEX NYLON INSERT LOCKNUTS		11
3	275638	5/16 x 1 1/2" HEX HEAD CAP SCREW		4
4	277303	COMET PUMP ASSEMBLY		1
5	220874	NAME PLATE		1
6	275543	POP RIVET, STAR 4-2AAD		4
7	701542	PUMP BRACE (COMET)		1
8	701543	MANIFOLD BLOCK (COMET)		2
9	275697	1/2" 3000LB FS SCRD 90 ELL		1
10	276341	RELIEF VALVE		1
11	277302	1/2" MNPT x 1/2 HB 90 ELBOW		1
12	275788	GAGE 0-1000 PSI		1
13	275670	1/2 x 1/4 FS SCRD HX BUSH		1
14	275368	HEX SOCKET 1/2" NPT PIPE PLUG		1
15	275689	1/2 NPT x 1/2 SWIVEL ADAPTER		1
16	277170	1/2" VALVE		2
17	275669	1/2 x 1 1/2" PIPE NIPPLE		3
18	275666	1/2" FS SCRD STREET ELL		2
19	729	1/4-20 THIN ESNA NUT		2
20	1020	5/16-18 x 1" HEX HEAD CAP SCREW		1
21	275932	STRAINER, HYPRO 3350-0040P		1
22	276102	3/4" BRASS CLOSE NIPPLE		1
23	275644	3/4" TEE		1
24	275874	3/4" FH x 3/4" FP ADAPTER		1
25	701544	INLET BRACE		1
26	276184	3/4 NPTx 1/2 90 DEG. HOSE BARB		1
27	276185	HOSE CLAMP		2
28	276099	3/4" HOSE QUICK DISCONNECT		1
29	560081	1/4-20 x 3/4" HHCS		2
30	276540	1/4" FLAT WASHER		21
31	701547	CONNECTION HOSE		1
32	277304	3/4 MP x 1" MH 90 DEG HOSE BARB		1
33	277220	U-BOLT		1
34	700641	HIGH PRESSURE HOSE 22"		1
35	701546	BY PASS HOSE		1
36	277305	5/16" x 3 3/4" LONG HHCS		2
37	701549	ROLL CAGE (XL)		1
38	701548	BASE PLATE (COMET)		1
39	276443	RUBBER FOOT		4
40	275639	5/16-18 x 1 3/4" HHCS		4
41	275426	1/4-20 ESNA STOP NUT		2
42	275335	HOSE CLAMP		2
43	277322	3/4" x 2 1/2" LONG BRASS NIPPLE		1
44	220577	PRESSURE HOSE ***NOT SHOWN***		1
45	277181	WARNING TAG ***NOT SHOWN***		1
46	34550	SUCTION HOSE ASSEMBLY *NOT SHOWN*		1
47	277200	SMALL U-BOLT		1
48	276986	1/2" M NPT x M QD		1
49	276987	1/2" F NPT x F QD*** NOT SHOWN***		1

WHEELER  
**REX**  
 465250 Parts

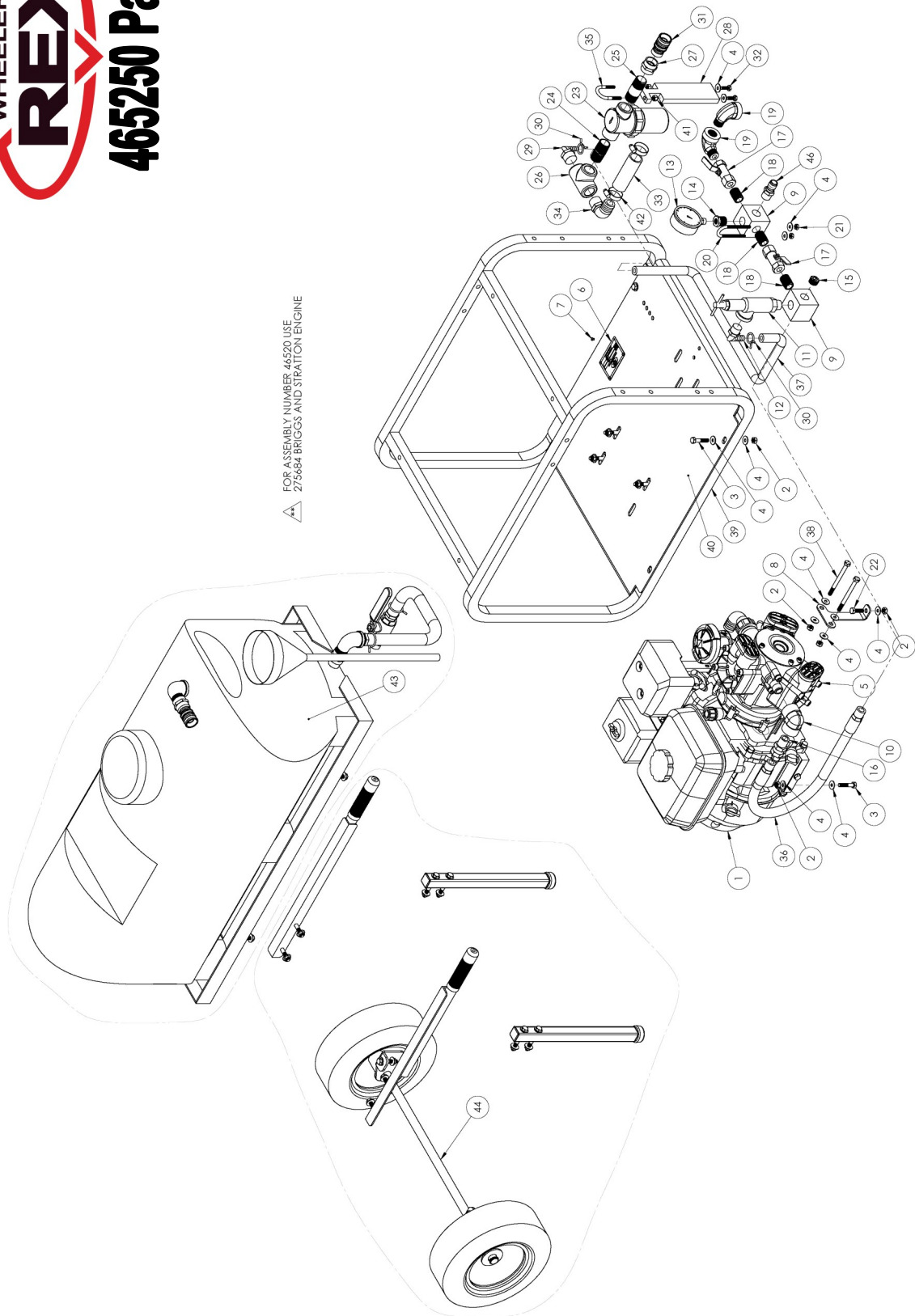

Item	Part No	Description	465250	Qty
1	276140	HONDA GX160		1
2	275857	5/16-18 HEX NYLON INSERT LOCKNUTS		9
3	275638	5/16 x 1 1/2" HEX HEAD CAP SCREW		6
4	276540	1/4" FLAT WASHER		21
5	277303	COMET PUMP ASSEMBLY		1
6	220874	NAME PLATE		1
7	275543	POP RIVET, STAR 4-2AAD		4
8	701542	PUMP BRACE (COMET)		1
9	701543	MANIFOLD BLOCK (COMET)		2
10	275697	1/2" 3000LB FS SCRD 90 ELL		1
11	276341	RELIEF VALVE		1
12	277302	1/2" MNPT x 1/2 HB 90 ELBOW		1
13	275788	GAGE 0-1000 PSI		1
14	275670	1/2 x 1/4 FS SCRD HX BUSH		1
15	275368	HEX SOCKET 1/2" NPT PIPE PLUG		1
16	275689	1/2 NPT x 1/2 SWIVEL ADAPTER		1
17	277170	1/2" VALVE		2
18	275669	1/2 x 1 1/2" PIPE NIPPLE		3
19	275666	1/2" FS SCRD STREET ELL		2
20	277200	SMALL U-BOLT		1
21	729	1/4-20 THIN ESNA NUT		2
22	1020	5/16-18 x 1" HEX HEAD CAP SCREW		1
23	275932	STRAINER, HYPRO 3350-0040P		1
24	276102	3/4" BRASS CLOSE NIPPLE		1
25	277322	3/4" x 2 1/2" LONG BRASS NIPPLE		1
26	275644	3/4" TEE		1
27	275874	3/4" FH x 3/4" FP ADAPTER		1
28	701544	INLET BRACE		1
29	276184	3/4 NPTx 1/2 90 DEG. HOSE BARB		1
30	276185	HOSE CLAMP		2
31	276099	3/4" HOSE QUICK DISCONNECT		1
32	560081	1/4-20 x 3/4" HHCS		2
33	701547	CONNECTION HOSE		1
34	277304	3/4 MP x 1" MH 90 DEG HOSE BARB		1
35	277220	U-BOLT		1
36	700641	HIGH PRESSURE HOSE 22"		1
37	701546	BY PASS HOSE		1
38	277305	5/16" x 3 3/4" LONG HHCS		2
39	701549	ROLL CAGE (XL)		1
40	701548	BASE PLATE (COMET)		1
41	275426	1/4-20 ESNA STOP NUT		2
42	275335	HOSE CLAMP		2
43	34563	25 GALLON TANK ASSEMBLY		1
44	34562	2 WHEEL & HANDLE ASSEMBLY		1
45	220577	PRESSURE HOSE ***NOT SHOWN***		1
46	276986	1/2" M NPT x M QD		1
47	276987	1/2" F NPT x F QD ***NOT SHOWN***		1

**WHEELER**  
**REX**  
**465260 Parts**

FOR ASSEMBLY NUMBER 46526 USE  
 275884 BRIGGS AND STRATTON ENGINE

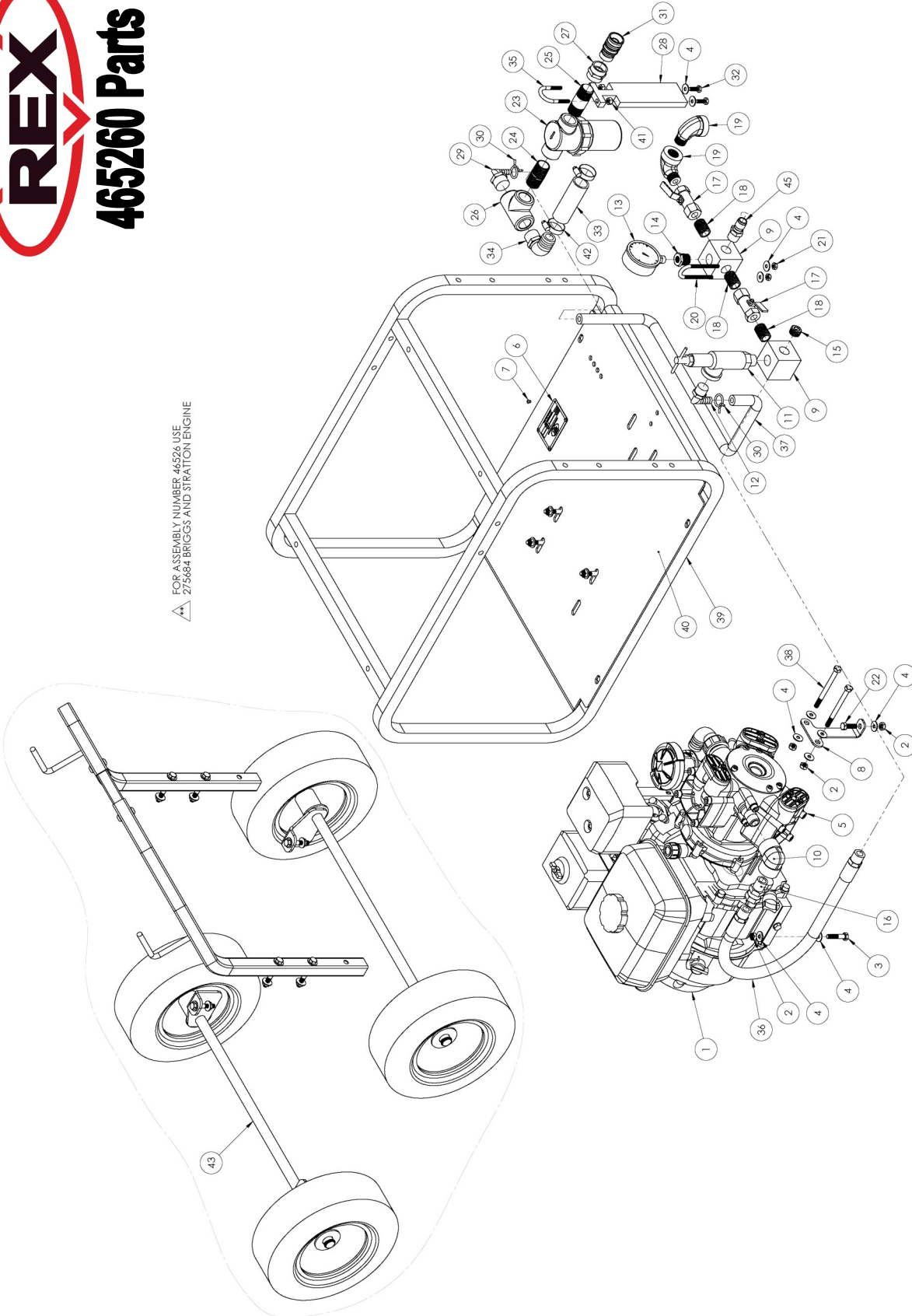

Item	Part No	Description	465260	Qty
1	276140	HONDA GX160		1
2	275857	5/16-18 HEX NYLON INSERT LOCKNUTS		7
3	275638	5/16 x 1 1/2" HEX HEAD CAP SCREW		4
4	276540	1/4" FLAT WASHER		17
5	277303	COMET PUMP ASSEMBLY		1
6	220874	NAME PLATE		1
7	275543	POP RIVET, STAR 4-2AAD		4
8	701542	PUMP BRACE (COMET)		1
9	701543	MANIFOLD BLOCK (COMET)		2
10	275697	1/2" 3000LB FS SCRD 90 ELL		1
11	276341	RELIEF VALVE		1
12	277302	1/2" MNPT x 1/2 HB 90 ELBOW		1
13	275788	GAGE 0-1000 PSI		1
14	275670	1/2 x 1/4 FS SCRD HX BUSH		1
15	275368	HEX SOCKET 1/2" NPT PIPE PLUG		1
16	275689	1/2 NPT x 1/2 SWIVEL ADAPTER		1
17	277170	1/2" VALVE		2
18	275669	1/2 x 1 1/2" PIPE NIPPLE		3
19	275666	1/2" FS SCRD STREET ELL		2
20	277200	SMALL U-BOLT		1
21	729	1/4-20 THIN ESAN NUT		2
22	1020	5/16-18 x 1" HEX HEAD CAP SCREW		1
23	275932	STRAINER, HYPRO 3350-0040P		1
24	276102	3/4" BRASS CLOSE NIPPLE		1
25	277322	3/4" x 2 1/2" LONG BRASS NIPPLE		1
26	275644	3/4" TEE		1
27	275874	3/4" FH x 3/4" FP ADAPTER		1
28	701544	INLET BRACE		1
29	276184	3/4 NPTx 1/2 90 deg. HOSE BARB		1
30	276185	HOSE CLAMP		2
31	276099	3/4" HOSE QUICK DISCONNECT		1
32	560081	1/4-20 x 3/4" HHCS		2
33	701547	CONNECTION HOSE		1
34	277304	3/4 MP x 1" MH 90 DEG HOSE BARB		1
35	277220	U-BOLT		1
36	700641	HIGH PRESSURE HOSE 22"		1
37	701546	BY PASS HOSE		1
38	277305	5/16" x 3 3/4" LONG HHCS		2
39	701549	ROLL CAGE (XL)		1
40	701548	BASE PLATE (COMET)		1
41	275426	1/4-20 ESNA STOP NUT		2
42	275335	HOSE CLAMP		2
43	34564	4 WHEEL & HANDLE ASSEMBLY		1
44	220577	PRESSURE HOSE ***NOT SHOWN***		1
45	276986	1/2" M NPT x M QD		1
46	276987	1/2" F NPT x F QD ***NOT SHOWN***		1





## WHEELER-REX LIMITED LIFETIME WARRANTY

WHEELER-REX covers its products with a Limited Lifetime Warranty, with exception of pipe threading machines which have a Limited Three Year Warranty (including electric motors). Warranties from manufacturers of components used in our products may pre-empt the Wheeler-Rex warranty. Wheeler-Rex warranties against defects in material or workmanship. To take advantage of this warranty, the complete product must be delivered prepaid to Wheeler-Rex or any WHEELER-REX AUTHORIZED SERVICE CENTER. No tools are to be returned to the factory without receiving prior authorization. Obviously, failures due to misuse, abuse, or normal wear and tear are not covered by this warranty. **NO OTHER WARRANTY, WRITTEN, OR ORAL, APPLIES. THERE ARE NO WARRANTIES WHICH EXTEND BEYOND THE DESCRIPTION ON THE FACE HEREOF.** No employee, agent, dealer, or other person is authorized to give any warranty on behalf of Wheeler-Rex. Warranted products will be repaired or replaced at our option, at no charge and returned to you via prepaid transportation. Such replacement or repair is the exclusive remedy available from Wheeler-Rex. Wheeler-Rex is not liable for damage of any sort, including incidental and consequential damages. Some U.S.A. states do not allow the exclusion or limitation of incidental or consequential damages, so the above limitation or exclusion may not apply. This warranty gives you specific legal rights, and you may also have other rights which vary from state to state.

Form # 1031

## WARNING

### GENERAL TOOL OPERATION WARNINGS

#### FOR ALL TOOLS-

1. **Keep Guards in Place** and in working order.
2. **Remove Adjusting Keys and Wrenches** from tool before turning it on.
3. **Keep Work Area Clean.** Cluttered areas and benches invite accidents.
4. **Avoid Dangerous Environment.** Don't use power tools in damp or wet locations. Keep work area well lit. Don't expose power tools to rain.
5. **If you must use an electric tool in a damp or wet location;** make sure it is plugged into a circuit which is protected by a ground fault interrupt.
6. **Keep Children Away. ALL VISITORS SHOULD BE KEPT A SAFE DISTANCE FROM WORK AREA.**
7. **Store Idle Tools** in dry, high, or locked-up place out of reach of children.
8. **Don't Force Tool.** It will do a better and safer job at the rate for which it is designed.
9. **Use Right Tool.** Don't force a small tool or attachment to do the job of a heavy-duty tool.
10. **Wear Proper Apparel.** No loose clothing or jewelry to get caught in moving parts. Rubber gloves and footwear are recommended when working outdoors.
11. **Use Safety Glasses.**
12. **Don't Abuse Cord.** Never carry tool by cord or yank it to disconnect from receptacle. Keep cord from heat, oil, and sharp edges.
13. **Secure Work.** Use clamps or vise to hold work when practical. It's safer than using your hand and it frees both hands to operate tool.
14. **Don't Overreach.** Keep proper footing and balance at all times.
15. **Maintain Tools Properly.** Keep tools sharp and clean for best and safest performance. Follow instructions for lubricating and changing accessories. Equipment operators must have proper maintenance & instruction sheets. Be sure the tool operator reads and understands this information. If you don't have current maintenance and instruction sheets, contact the factory & we will supply them at no charge.
16. **Disconnect Tools** when not in use; before servicing; when changing accessories such as dies, cutters, etc.
17. **Avoid Accidental Starting.** Don't carry plugged-in tool with finger on switch. Be sure switch is off when plugging in.
18. **Outdoor Use Extension Cords.** When tool is used outdoors, use only extension cords suitable for use outdoors and so marked.
19. **Wear Ear Protection** if exposed to long periods of very noisy shop operations.
20. **Do not operate tools** while under the influence of alcohol, drugs or medication.



Wheeler Rex ▪ 3744 Jefferson Road ▪ Ashtabula, Ohio 44005  
Tel: 800-321-7950 or 440-998-2788 ▪ Fax: 440-992-2925  
[wheeler@wheelerrex.com](mailto:wheeler@wheelerrex.com) ▪ [www.wheelerrex.com](http://www.wheelerrex.com)