

Job Name/Location:

Tag #:

Date:

For:	File	Resubmit
	Approval	Other_____

PO No.:

Architect: _____ GC: _____

Engr: _____ Mech: _____

Rep: _____
(Company) (Project Manager)

LQ120HV4 Single Zone Low Wall Console

Outdoor Unit (ODU) - LUU127HV, Indoor Unit (IDU) - LQN120HV4



Performance:

Cooling:

Cooling (Min~Rated~Max, Btu/h)	4,500 ~ 10,200 ~ 13,460
SEER	20.8
EER	12.60

SEER - Seasonal Energy Efficiency Ratio EER - Energy Efficiency Ratio

Heating:

Heating (Min~Rated~Max, Btu/h)	5,970 ~ 13,000 ~ 15,000
HSPF	10.2

HSPF - Heating Seasonal Performance Factor

Cooling Nominal Test Conditions: Heating Nominal Test Conditions:
Indoor: 80°F DB / 67°F WB Indoor: 70°F DB / 60°F WB
Outdoor: 95°F DB / 75°F WB Outdoor: 47°F DB / 43°F WB

Electrical:

Power Supply ¹ (V/Hz/Ø)	208-230/60/1
------------------------------------	--------------

Outdoor Unit:

MOP (A)	15
MCA (A)	12.3
Cooling Rated Amps (A)	9.95
Heating Rated Amps (A)	9.95
Compressor(A)	9.0
Fan Motor (IDU + ODU) (A)	0.7 + 0.25
Cooling Power Input (kW)	0.4 ~ 0.81 ~ 1.35
Heating Power Input (kW)	0.55 ~ 1.25 ~ 1.58

MOP - Maximum Overcurrent Protection MCA - Minimum Circuit Ampacity

Piping:

Liquid Line (in., O.D.)	1/4
Vapor Line (in., O.D.)	3/8
Additional Refrigerant (oz./ft.)	0.22
Max. Pipe Length ² (ft.)	66
Piping Length (no add'l refriger., ft.)	24.6
Max. Elevation (ft.)	49

Features:

- Hot start
- Inverter (variable speed fan)
- Auto restart
- Control lock
- Group control
- Timer (on/off)
- Sleep Mode
- Optional Wi-Fi Control

Included Accessories:

Wireless Remote Controller — AKB75735410

Optional Accessories:

- | | |
|--|---|
| <input type="checkbox"/> MultiSITE™ CRC1 - PREMTBVC0 | <input type="checkbox"/> Drain Pan Heater - PQSH1202 |
| <input type="checkbox"/> MultiSITE CRC1+ - PREMTBVC1 | <input type="checkbox"/> Dry Contact for Thermostat - PDRYCB320 |
| <input type="checkbox"/> MultiSITE Comm. Mgr. - PBACNBTR0A | <input type="checkbox"/> Simple Dry Contact (1 Contact, 24VAC external power) - PDRYCB100 |
| <input type="checkbox"/> AC Smart 5 - PACS5A000 | <input type="checkbox"/> Dry Contact for Economizer - PDRYCB400 |
| <input type="checkbox"/> Simple Controller - PREMTCC00U | <input type="checkbox"/> Premium Remote Controller - PREMTA000 |
| <input type="checkbox"/> Wi-Fi module with cable - PWFMD200 | <input type="checkbox"/> PI-485 - PMNFP14A1 |
| <input type="checkbox"/> Low Ambient Wind Baffle (Cooling operation to -4°F) ZLABGP01A | |

Operating Range:

Outdoor Unit:

Cooling (°F DB)	0 to 118
Heating (°F WB)	-4 to 64

Indoor Unit:

Cooling (°F WB)	57 to 77
Heating (°F DB)	59 to 81

System Data:

Refrigerant Type	R410A
Refrigerant Control	EEV
Refrigerant Charge (lbs.)	38.8
ODU Sound Pressure Max (Cool / Heat) ±3 dB(A) ³	49 / 52
IDU Sound Pressure (H/M/L) ±3 dB(A) ³	39 / 32 / 27
ODU Net / Shipping Weight (lbs.)	74.5 / 80
IDU Net / Shipping Weight (lbs.)	35.9 / 42.5
Heat Exchanger Coating	GoldFin™

Fan:

ODU Type	Propeller
IDU Type	Sirocco
Fan Speeds (Fan/Cool/Heat)	4 / 5 / 5
Fan Quantity (ODU + IDU)	1 + 1
Motor/Drive	Brushless Digitally Controlled/Direct
ODU Air Circulation (CFM)	988
Air Flow (Max/H/M/L) (CFM)	353 / 318 / 244 / 184
Dehumidification Rate (pts/hr)	2.5

Notes:

1. Acceptable operating voltage: 187V-253V.
2. Piping lengths are equivalent.
3. Sound Pressure levels are tested in an anechoic chamber under ISO Standard 3745.
4. All communication / connection (power) cable from the outdoor unit to the indoor unit is field supplied and is to be minimum four-conductor, 14 AWG, stranded, shielded or unshielded (if shielded, it must be grounded to the chassis of the outdoor unit only), and must comply with applicable local and national codes.
5. See Engineering Manual for sensible and latent capacities.
6. Power wiring cable size must comply with the applicable local and national code.
7. The indoor unit comes with a dry helium charge.
8. This data is rated 0 ft. above sea level, with 24.6 ft. of refrigerant line and a 0 ft. level difference between outdoor and indoor units.
9. Must follow installation instructions in the applicable LG installation manual.



For a complete list of available accessories, contact your LG representative.

For continual product development, LG reserves the right to change specifications without notice.

© LG Electronics U.S.A., Inc., Englewood Cliffs, NJ. All rights reserved. "LG Life's Good" is a registered trademark of LG Corp. /www.lghvac.com

SB_SZ_Console_LQ120HV4_2020_05_20_120052

Page 1 of 3

LQ120HV4

Single Zone Low Wall Console

Outdoor Unit (ODU) - LUU127HV, Indoor Unit (IDU) - LQN120HV4



Tag No.: _____

Date: _____

PO No.: _____

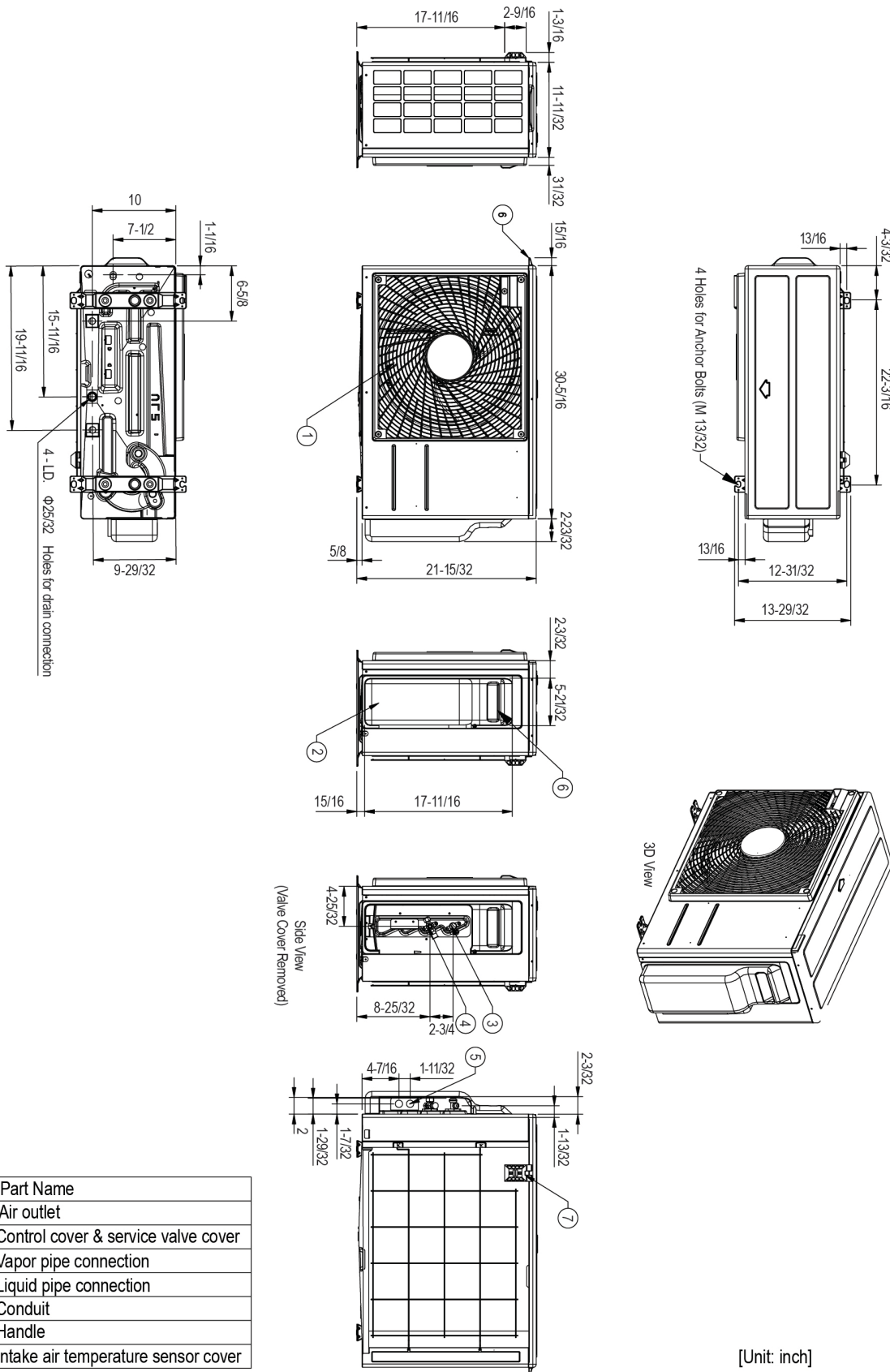

No.	Part Name
1	Air outlet
2	Control cover & service valve cover
3	Vapor pipe connection
4	Liquid pipe connection
5	Conduit
6	Handle
7	Intake air temperature sensor cover

[Unit: inch]

Job Name/Location: _____

LQ120HV4

Single Zone Low Wall Console

Outdoor Unit (ODU) - LUU127HV, Indoor Unit (IDU) - LQN120HV4



Tag No.: _____

Date: _____

PO No.: _____

