

Tips on Installing and Maintaining Rain Bird Residential Valves

Valves are an essential part of any sprinkler system. They are the link between the "brains" of the system (the timer) and the sprinkler heads to turn the water on and off.



Customer Support Center
6991 E. Southpoint Rd., Bldg. #1
Tucson, AZ 85706
1-800-RAIN-BIRD

Valves are an essential part of any sprinkler system. They are the link between the "brains" of the system (the timer) and the sprinkler heads, to turn the water on and off.

Most automatic sprinkler systems are set up with two types of valves. A brass "gate valve" or "ball valve" is usually located right after the "tee" where the sprinkler system cuts off from the main source of water to the house. This valve, referred to as the "shutoff valve," is used to shut down the sprinkler system for repairs or winterizing without shutting off the water to the entire house. It is recommended that all systems be equipped with a shutoff valve installed in a box for easy access.

The second type of valve is the sprinkler "zone valve." Each zone valve is piped to a set of sprinklers. When the valve is turned on, either by hand or in response to an electronic signal from the timer, all the sprinklers piped to that particular valve go on. In most cases, there are several valves located together (called a manifold), each con-

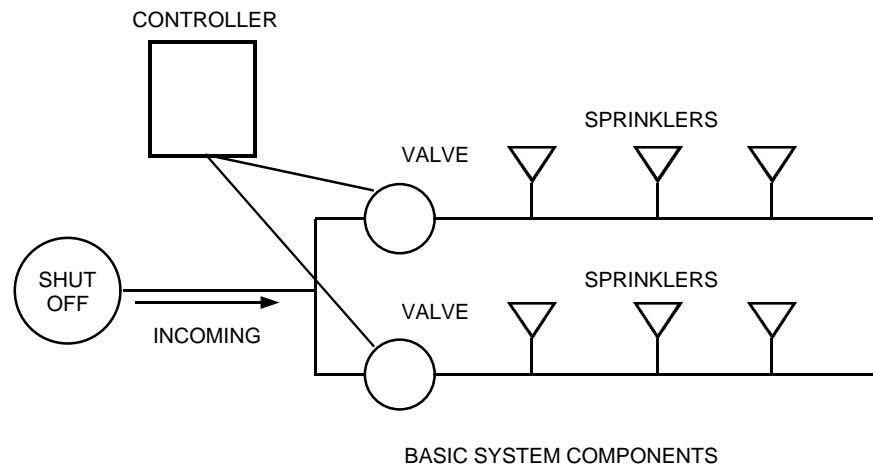

Why are several valves needed? All systems are limited by a combination of the pressure of the water (psi) and the number of gallons per minute (gpm) available. Each sprinkler uses a certain number of gallons per minute of water. This release of water through the nozzle reduces water pressure to a certain degree while the system is working. For maximum performance, each zone is controlled by one valve and is set up with the proper amount of sprinklers so that the psi and gpm capacity of the system is not exceeded. The purpose of this information is to address questions and problems related to zone valves.

Types of Zone Valves

There are two basic types of zone valves commonly available. Anti-siphon valves have a built-in backflow device to prevent possibly contaminated water from flowing backward into the household supply. If approved by your local codes, these types of valves provide inexpensive backflow protection. Anti-siphon valves must be installed at least 6" above the highest sprinkler head on the line in order for the backflow device to work properly. Both automatic and manual versions are available.

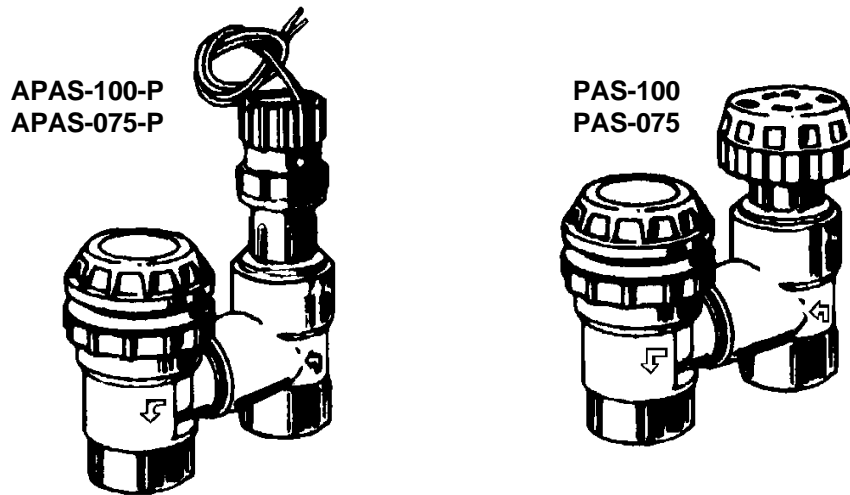

The second type of valve is an "in-line" valve. It is installed below ground, preferably in a valve box, for ease of maintenance. A separate backflow preventer is required for backflow protection. In-line valves are automatic valves.

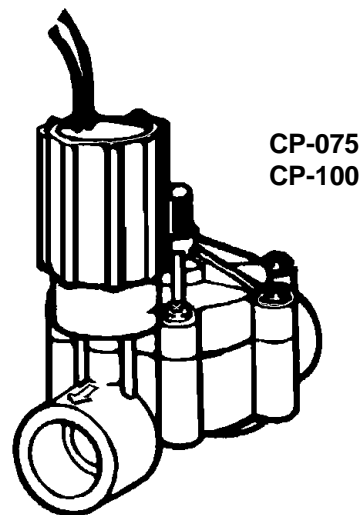

Anti-Siphon Valves

Anti-siphon valves are an inexpensive choice and easy to install and maintain. The built-in anti-siphon backflow device prevents potential contamination of household water supplies from fertilizers and other toxic chemicals which may enter the system. Check your local codes for the types of backflow protection required in your area. Electric models are simple to hook up to a timer for automatic watering. They are best suited to plans where there is not more than a slight rise in elevation, and fairly clean source water.

Caution: This valve is designed as a zone valve and as such may suffer severe damage if installed where constant pressure is placed on the outlet (sprinkler) side of the valve. The manual version *is not* suitable for use in a continuous open position as a main shutoff valve or as a means of inexpensive backflow prevention for an entire system; nor are the automatic models to be used as a master valve where other valves will be installed downstream.

(**Note:** A master valve is an electric valve that is automatically activated to open and allow the flow of water through, only when the zone valves downstream are activated.)

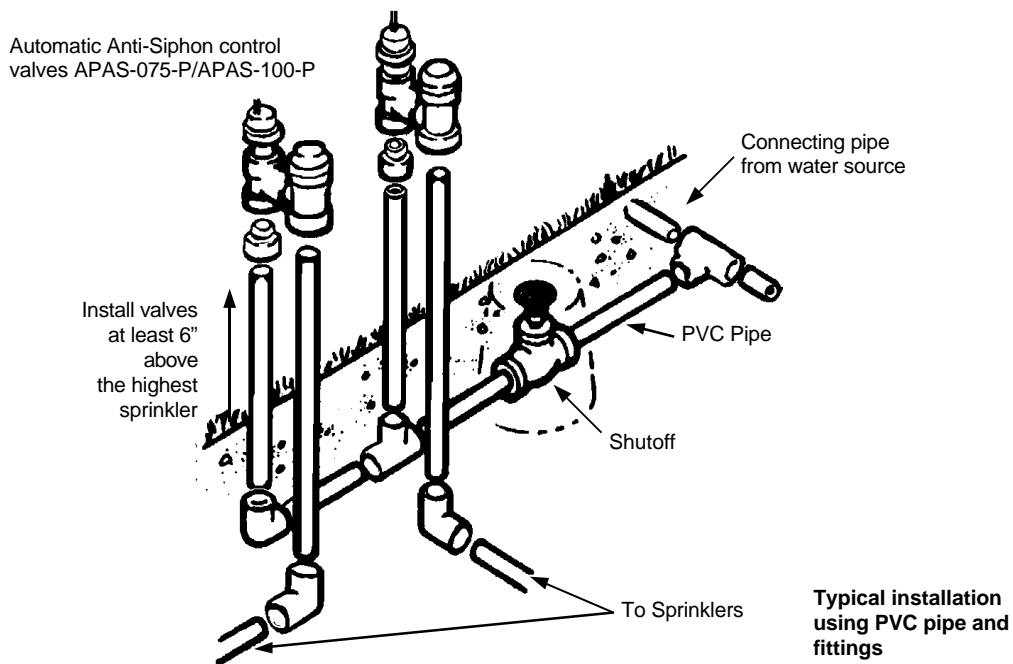

In-Line Valves

In-line valves, installed below ground level, are suitable for sites with all types of elevation changes. Because of their protected location, in-line valves are less likely to be tampered with by children or vandals, and less likely to incur freeze damage than above ground models. In-line valves do not afford backflow protection.

In situations where the water is pumped from a lake, well, ditch, or other "dirty" water source, sand and other debris should be filtered from the line through a filter with a 100 mesh screen. If water supply is also used as a drinking water source, a separate backflow prevention device is required to prevent potential contamination should fertilizers or toxic chemicals in the water be siphoned backwards through the lines.

If your water is supplied by a municipal water system, check with your local Rain Bird dealer or plumbing supplier for the type of backflow prevention device required in your area. For specific information about backflow and the types of backflow prevention devices available, please call our toll-free number. 1-800-RAIN-BIRD, and request a "Backflow Prevention Handbook."

In-line valves are installed below ground, protected by a valve box. An in-line valve is also suitable for use as a master valve.

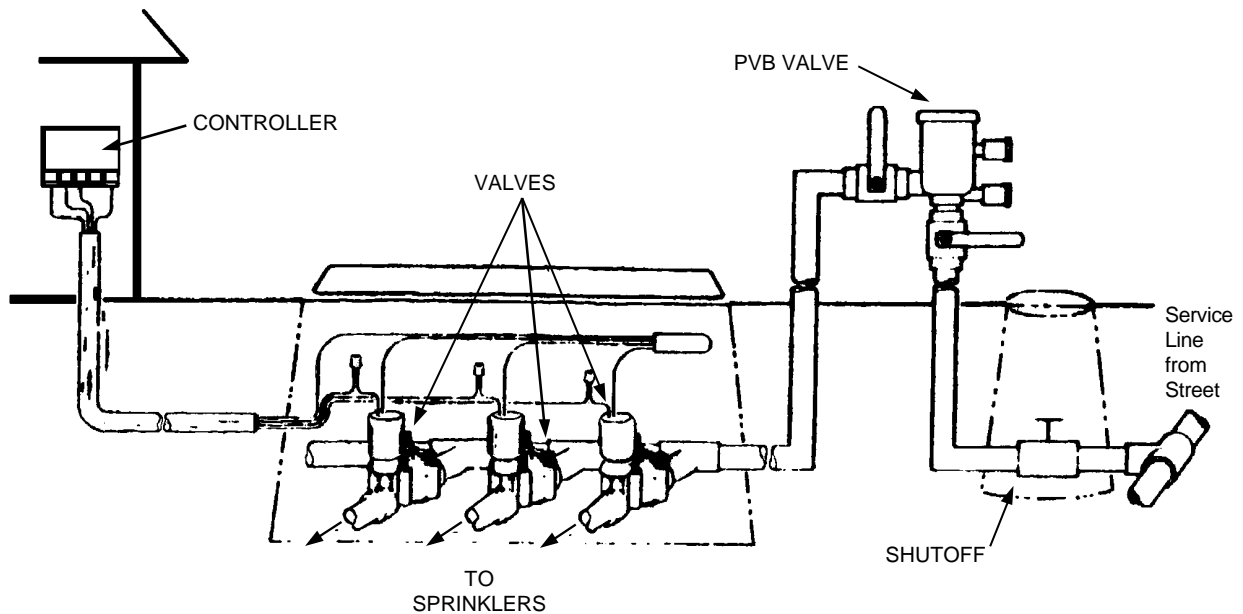

Tips On New Installations

Tapping Into Your Water Source

Turn off the water at the meter. Cut into your household service line and install a brass slip-type compression tee, after the meter. The cut can be done anywhere on the line, depending on the layout of your system and the location of your first manifold. Unless unregulated static pressure is over 80 psi, tap into the line before the household pressure regulator. In freezing climates, you will probably be tapping into your source inside a basement.

Next, install a gate or ball valve to act as your system shutoff valve. House the valve in a valve box for easy access in below ground situations. Once this valve is installed and tested, the valve at the meter may be left open for water usage inside the house. In freezing climates, your next step will be to install a manual drain valve so that the water can be drained from the pipes between the zone valves and the shut-off valve.

Install Schedule 40 PVC, thick-walled pipe up to the valves. In basement installations, you will need to drill a hole through the wall to direct the pipe out to the valves. For convenience in "blowing out" the system for winter, access to the line by means of a tee with a capped 1" riser may be installed at this point.

If a backflow preventer is to be used, install it outside at the proper height.

FLUSH, FLUSH, FLUSH. . . Turn on the water at the shutoff valve and flush the pipes free of dirt.

Meter in House

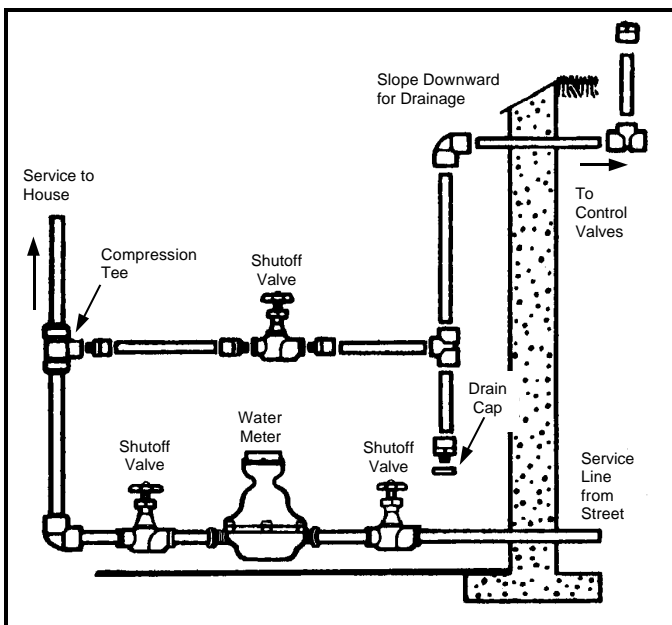

Meter in Yard

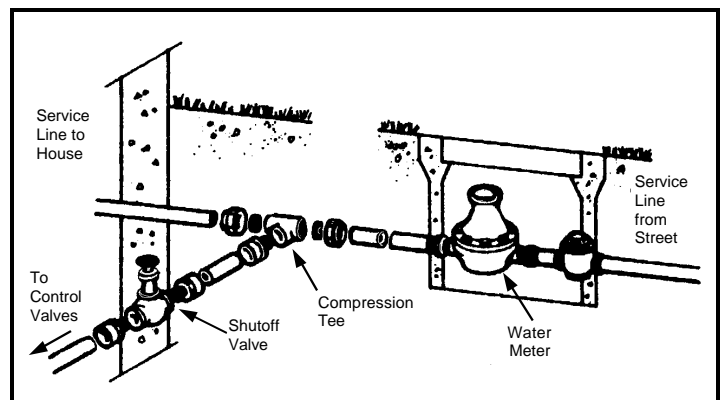

Installing the Manifold

If you are installing a new valve manifold, keep in mind that the location should be easily accessible for maintenance. Locate the manifold where you are not likely to be sprayed by the sprinklers when turning the system on manually. On larger systems, separate manifolds may be required for the front and back yards. It is a good idea to keep a plan showing where all in-ground valves and pipes have been installed.

Be sure to flush the line coming up to the manifold, before installing the valves. Test and flush each line before sprinklers are attached. Most valves have a flush mode which allows a little extra water through the valve to clean it out.

To Flush:

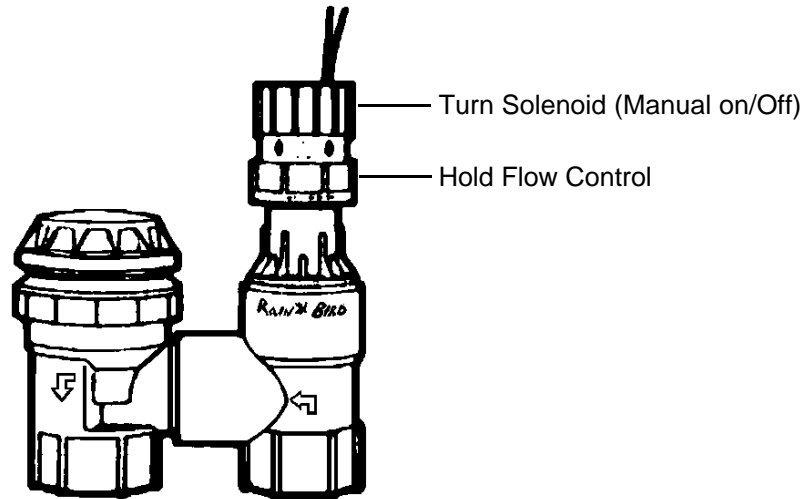

Turn black SOLENOID counterclockwise (do not turn gray ring) until a small amount of water discharges between SOLENOID and FLOW CONTROL ring.

Anti-Siphon Valves Grouped Above Ground

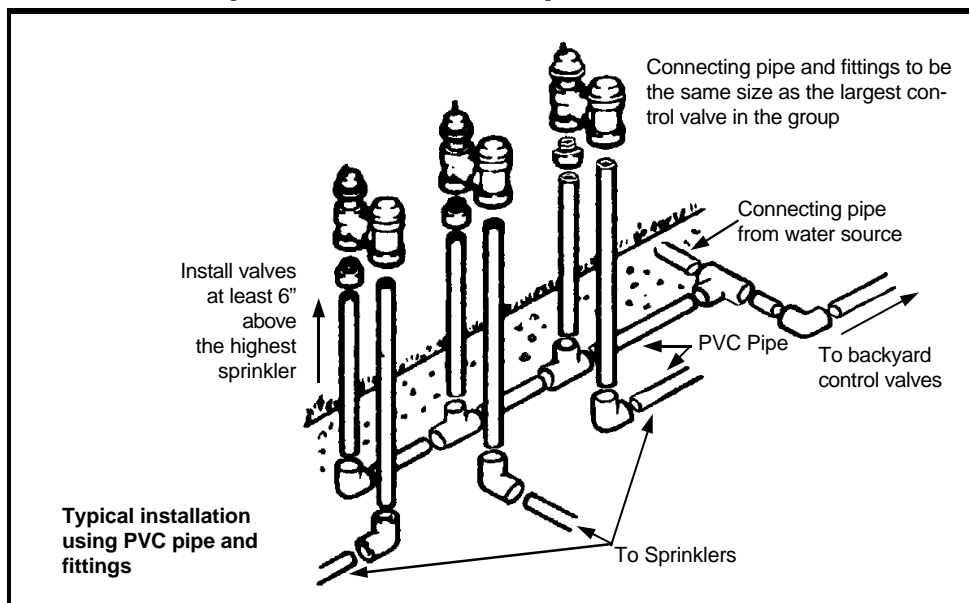

To Flush:

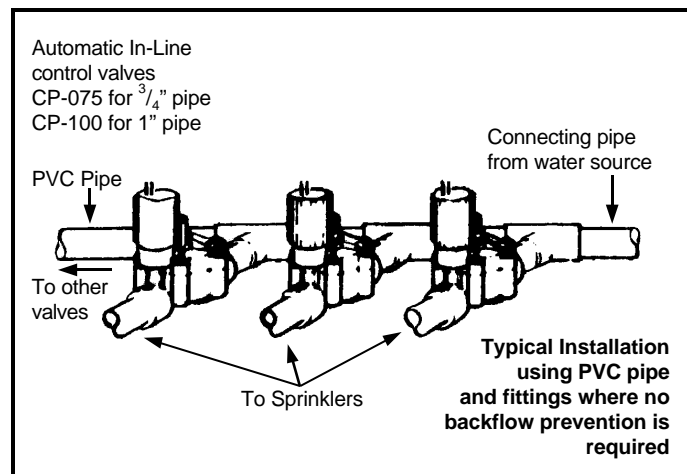
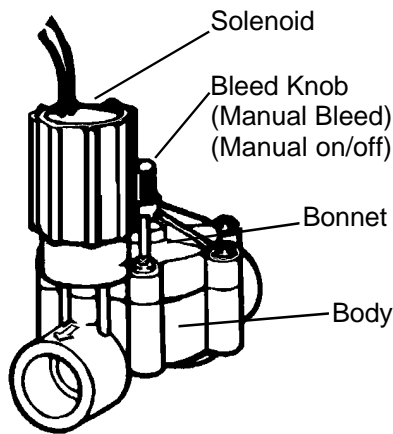

Turn bleed knob 1 full turn counterclockwise and allow water to spray out for 10-15 seconds; turn back to clockwise position.

Installing the Manifold (Continued)

Tip: Partially assembling the manifold ahead of time will make the job easier. Be sure that the valve is installed horizontally according to the arrows printed on the body for the direction of flow. Valve operation may be erratic and valve warranty is void if installed backward or in a vertical position. Call our toll-free Technical Services Hotline for any questions on system installation: 1-800-RAIN-BIRD.

CAUTION: Do *not* use plumber's pipe dope on valve threads when installing. Chemicals in the pipe dope may react with the plastic in the valve body causing the valve to weaken and crack at the threads. Three wraps of Teflon tape should be sufficient to create a leak-proof seal.

How to Operate

Several models of Rain Bird 24 Volt valves are available for home use. Minimum current requirements for opening the smaller valves is .30 amps and for holding the valve open is .19 amps. Larger valve models have slightly higher requirements. All Rain Bird valves are designed to work with Rain Bird timers and other timers that have a power output sufficient to activate the valve. Your Rain Bird valve offers some simple features you should be familiar with. **Note:** Some valves have only part of these features. See the diagram above and on the previous page for information on flushing the valves.

- a. Flow control - Regulates the amount of water passing through the valve. (Not available on all models.)
- b. Manual bleed - Turns the valve on manually by "bleeding" water off of the diaphragm. External bleed models have a knob or screw to turn and the water sprays out of the top of the valve. Internal bleed models have a open/close knob or require a $\frac{1}{4}$ turn of solenoid and water bleeds off inside the valve.
- c. Manual On/Off - Turn solenoid $\frac{1}{4}$ turn counterclockwise to turn valve on manually.

Troubleshooting

How the Valve Works

It is easier to troubleshoot valves if you know a little about how the valve works. When an electrical impulse is transmitted to the solenoid (black cylinder with wires), an electromagnetic field causes a small metal plunger in the solenoid to move upward. When the plunger moves upward, a small hole (port) in the valve is uncovered. Water in the chamber above the closing mechanism (either diaphragm or piston) flows through the port and out of the valve, relieving water pressure needed to hold the valve closed. At this point, the pressure of the incoming flow of water is now greater than the pressure in the chamber above the piston/diaphragm, and the force of the water pushing up underneath the piston/diaphragm opens the valve.

When the solenoid is de-energized, the plunger moves down, closing the small port. Water flowing through a small hole in the closing mechanism refills the chamber above the piston/ diaphragm and builds up pressure. The increased pressure forces the piston/diaphragm downward, thus closing the valve. All valves have a range of pressure and water flow that must be maintained in order to work properly.

Now that you have an idea of the way the valves work, you can see why sufficient pressure and flow are important. If a problem does occur, it is also very important to ensure that the small internal ports are not blocked by debris. Adequate flushing is the key to success in a new installation.

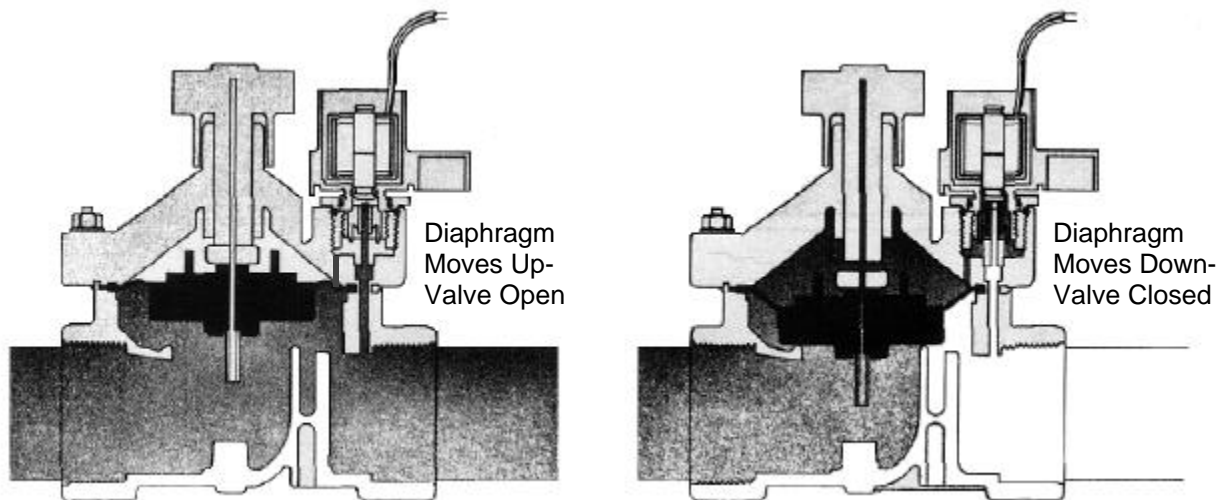

How a diaphragm valve opens and closes.

TROUBLESHOOTING GUIDE

<p>1. For any problem, check the basics first.</p>	<p>A. Is timer plugged in and properly programmed? B. Is master shut off valve open? C. Is flow control on valve in an "open" or "flow" position? Not all models have this feature. Check the instructions that came with your valve, or see "How to Operate" section of this packet. D. Are water pressure and flow rate adequate for your particular valve model? (Check the instructions that came with the valve or call us toll free at 1-800-RAIN-BIRD for the requirements of your particular Rain Bird valve model.) If your pressure is too low, investigate these causes:</p> <ul style="list-style-type: none"> • Pressure drain from washing machines, showers, etc. or broken pipe, • Master shutoff valve not fully open, • Blockage in main supply line; to repair, cut main line, flush line, and repair cut; • Too many heads on line; redesign system layout to reduce the number of heads operating at once. <p>E. Is valve in "Manual Off" position? See "How to Operate" section of this packet. F. If your system is supplied by a pump, is it working?</p>		
SYMPTOM	CAUSE	DIAPHRAGM VALVE REMEDY (See Valve Disassembly Procedure A)	PISTON-TYPE VALVE REMEDY (See Valve Disassembly Procedure B)
<p>2. Valve won't turn on with timer.</p>	<p>A. Check the Basics as in No. 1 above.</p> <p>B. No power between timer and valves.</p> <p>C. Solenoid burned out or clogged.</p> <p>D. Valve opening mechanism damaged or clogged with debris. Bleed ports clogged.</p> <p>E. Valve installed backwards</p>	<p>• If all basics check out, see if the valve will work manually. On some models you will need to turn the solenoid 1/4 turn counter-clockwise. On other models, turn the screw in the center of the bonnet (water should spray out of the top of the valve temporarily). Check your valve operating instructions or refer to section entitled "How to Operate," in this packet of information. If the valve works manually, go on to step 2-B. If the valve doesn't work, go on to step 2-D.</p> <p>• Check by pressing the "Manual Start" button of the timer and advance to the desired station. Attach a circuit tester (voltmeter) to the common terminal and the station terminal of the timer. If you do not get a 24-27 volt reading, the problem is in the timer.</p> <p>• Check for shorted or broken wiring. Follow directions as above, except attach voltmeter to common wire and station wire nearest valve. If you do not receive a 24-27 volt reading, replace or repair wiring.</p> <p>• The solenoid should make a distinct "click" when activated. If timer and wiring check out, try unscrewing the solenoid and swapping it with a nearby valve of the same model. Using the "Manual Start" on your timer, check the station again to see if the borrowed solenoid activates the valve. If so, replace solenoid. If not check 2-D.</p> <p>• See if you can flush debris from the valve by using the flush mode. If not, turn off the water, disassemble, inspect and clean the valve (See Valve Disassembly Procedure A). Pay particular attention to cleaning the small bleed ports underneath the solenoid and on the surface of the diaphragm. Check to see that the diaphragm is not torn damaged. Replace diaphragm if damaged. If water is particularly dirty, install a 100 mesh or finer filter before the valve to prevent future grit build-up.</p> <p>• Reinstall valve so that water flow is the same direction as arrows embossed on valve.</p>	<p>• If all basics check out, see if the valve will work manually by holding onto the gray flow control ring and turning the solenoid 1/4 turn counter-clockwise. If the valve works manually, go on to step 2-B. If the valve doesn't work, go on to step 2-D.</p> <p>• See recommendations at left for diaphragm valve.</p> <p>• See recommendations at left for diaphragm valve.</p> <p>• See recommendations at left for diaphragm valve.</p> <p>• Turn off the water. Remove the actuator and examine piston (See Valve Disassembly Procedure B). Remove dirt and deposits. If removing and cleaning the piston does not help, replace with the PRK-100 piston replacement kit. If the problem is continual, install a 150 mesh or finer filter before the valve to prevent future grit build-up,</p> <p>• See recommendations at left for diaphragm valve.</p>

TROUBLESHOOTING GUIDE

SYMPTOM	CAUSE	DIAPHRAGM VALVE REMEDY (See Valve Disassembly Procedure A)	PISTON-TYPE VALVE REMEDY (See Valve Disassembly Procedure B)
<p>3. Valve won't turn off with timer.</p>	<p>A. When the valve won't turn off with the timer, the foremost goal is to stop the flow of water. When this is accomplished, check steps B through D for trouble-shooting procedure.</p> <p>B. Solenoid burned out or plunger clogged.</p> <p>C. Valve closing mechanism stuck in open position due to debris or damage.</p> <p>D. Damaged or misaligned parts allow water to leak from valve.</p> <p>E. Valve set in "Manual On" mode.</p>	<ul style="list-style-type: none"> • Put timer in auto/off (Rain Shutoff) mode. If watering continues. . . • Unplug timer. If this stops the watering, the problem is probably in the timer. If watering continues. . . • Turn flow control knob (if there is one) to lowest flow position. If this does not shut off the flow completely. . . • Turn off manual main shut off valve to sprinkler system. • Check solenoid as in 2-C. Check for dirt impeding the movement of the plunger. To do this, turn off the water and remove power to the solenoid. Unscrew the solenoid. Sometimes the plunger inside the solenoid can become stuck in the upward position due to dirt in the solenoid. Run water into the solenoid to dislodge dirt. Push a piece of wire into the small hole in the retainer at the bottom of the solenoid to see if the plunger inside will move up and down freely. If not, replace the solenoid. • See Valve Disassembling Procedure A. Check small ports for blockage by debris; rinse and inspect diaphragm and diaphragm seat for dirt or damage. Replace diaphragm if damaged. • Check valve body and bonnet for cracks. Check integrity of seal between body and bonnet and solenoid and bonnet. Repair or replace parts as necessary to stop leak. • Depending on the model, you will need to be sure the solenoid is tightened into the full clockwise position ("Manual Off") or turn the bleed screw or knob on top of the valve clockwise to tighten. See section entitled "How to Operate." 	<ul style="list-style-type: none"> • See recommendations at left for diaphragm valve. • See recommendations at left for diaphragm valve. • Turn gray flow control ring on valve clockwise until resistance is felt. This is the lowest flow position. If more than one valve is affected or if turning the flow control does not shut off the flow completely... • See recommendations at left for diaphragm valve. • See recommendations at left for diaphragm valve. • Remove piston and check for debris that may be restricting movement (See Valve Disassembling Procedure B). If piston is damaged replace with PRK-100 piston replacement kit. • Check for crack in actuator or bent o-rings. Replace actuator or o-rings to stop leak. • Hold gray flow control ring and turn solenoid clockwise until resistance is felt.
<p>4. Water leaks out at sprinkler heads when station is off.</p>	<p>A. Closing mechanism dirty or damaged and does not seat properly.</p> <p>B. Valve not fully in "Manual Off" mode.</p> <p>C. Solenoid burned out or obstructed.</p> <p>D. Low head drainage.</p>	<ul style="list-style-type: none"> • See Valve Disassembly Procedure A. Check small ports for blockage by debris; rinse and inspect diaphragm and diaphragm seat for dirt or damage. Replace diaphragm or valve body if damaged. • See 3-E above. • Turn off water. Remove solenoid. Check for twisting or damage to solenoid O-ring. Check solenoid plunger as in 3-B above. Rinse bottom of solenoid and seating surface inside valve. Replace solenoid if damaged. • It is normal for water to temporarily continue to drain from the piping through the lowest head on the line. The longer the piping, and the lower the slope of the pipe, the longer this will take. 	<ul style="list-style-type: none"> • See Valve Disassembly Procedure B. If thoroughly cleaning the piston and housing does not help, replace piston with PRK-100 piston replacement kit. • See 3-E above • See recommendations at left for diaphragm valve. • Same for all types of valves. See recommendations at left for diaphragm valve

TROUBLESHOOTING GUIDE

SYMPTOM	CAUSE	DIAPHRAGM VALVE REMEDY (See Valve Disassembly Procedure A)	PISTON-TYPE VALVE REMEDY (See Valve Disassembly Procedure B)
4. Water leaks out at sprinkler head when station is off. (Continued)	D. Low head drainage. (Continued)	<p>Stop watering on the soggy zone for two days. Check the lowest head on the line.</p> <p>If area is very wet or a small amount of water drips from sprinkler, see 4-A and 4-B above. If area around sprinkler has dried out somewhat, the problem is probably due to drainage from the piping.</p>	
5. Valve won't turn off manually.	<p>A. Valve in "Manual On" mode.</p> <p>B. Valve closing mechanism stuck in open position.</p> <p>C. Solenoid energized</p>	<ul style="list-style-type: none"> • See 3-E above. • See 3-C above. • Stop power to valve. 	<ul style="list-style-type: none"> • See 3-E above. • See 3-C above. • Stop power to valve
6. Valve won't turn on manually.	<p>A. Flow control in closed position.</p> <p>B. Valve opening mechanism blocked by debris.</p> <p>C. Valve in "Manual Off" mode.</p>	<ul style="list-style-type: none"> • See I-C above. • See 2-D above. • See 2-A above. 	<ul style="list-style-type: none"> • Turn gray ring counterclockwise to increase flow. • See 2-D above. • See 2-A above.
7. Water leaks out at valve.	<p>A. Leaking round pipe connections.</p> <p>B. Leaking around actuator assembly.</p> <p>C. Leaking between bonnet and body.</p> <p>D. Leaking under anti-siphon cap. (Anti-siphon models only).</p>	<ul style="list-style-type: none"> • Tighten connections (use teflon tape only). • Not applicable. • Check that diaphragm washer is properly in place. Tighten bonnet screws. • Not applicable. • Not applicable • Not applicable • Not applicable 	<ul style="list-style-type: none"> • See recommendations at left for diaphragm valve. • Tighten actuator to body (See Valve Disassembly Procedure B) Be sure O-ring seal is in place. Do not use pipe dope or teflon tape or tighten with such force as to crack plastic valve body. • Not applicable. • Float under cap is not moving freely due to debris. Turn off water and unscrew cap. Clean out area around float and replace float and cap. • Valves not installed 6" higher than highest sprinkler head. Raise position of valve or redesign system. • Insufficient water pressure (See I-D) • Vacuum breaker cap or valve body cracked. Replace as necessary.
8. Valve slams on/off (water hammer)	<p>A. Excessive water pressure.</p> <p>B. Valve closing/opening mechanism worn.</p> <p>C. Air bubble in line</p> <p>D. Valve too small for amount of flow.</p>	<ul style="list-style-type: none"> • Install pressure regulator on line before valves to reduce pressure. • Replace diaphragm with model number appropriate for your valve. Call our Technical Service hotline for assistance in identifying valve or part numbers. 1-800-RAIN-BIRD • Shut off water at main shut off valve and drain the line to release air bubble. Slowly refill the line. • Replace with larger valve 	<ul style="list-style-type: none"> • See recommendations at left for diaphragm valve. • Replace piston with PRK-100 piston replacement kit. • See recommendations at left for diaphragm valve. • Not applicable
9. Water runs continuously when valve is not activated; shuts off when valve is activated.	A. Valve installed backwards.	• Reinstall valve according to arrows on valve depicting direction of flow.	• Not applicable.

Disassembling the valve for cleaning or part replacement — Disassembly Procedure A

To inspect the inside of the valve for cleaning or replacement of the diaphragm use the following procedure:

1. Shut off the water at the master shut off valve.
2. Unscrew all bonnet screws. On some models, the bleed screw and/or flow control knob will also need to be removed.
3. Remove bonnet assembly to expose the spring, diaphragm, and rubber gasket (if any) and filter (if any). Remove and inspect the spring, diaphragm, and rubber gasket for wear or damage. Inspect the diaphragm for clog or a tear in the small hole on its surface.
4. Inspect the valve body for dirt on the diaphragm seat.
5. Inspect the bonnet for dirt clogging the small bleed port near the solenoid.
6. Rinse dirt off if necessary, or use a wire to gently dislodge dirt from the bleed port.
7. Install new diaphragm if necessary. Do not forget to replace the spring. Some new replacement diaphragms are an all-in-one design and do not have a separate rubber gasket to install. Be sure that the holes line up.
8. Press the bonnet firmly back in place. Replace the screws and tighten. Pressure test the valve to assure that all of the screws are tight enough to prevent any water leakage between the valve body and bonnet.

To replace the solenoid:

1. Unscrew the solenoid.
2. Check for debris clogging the small port where the solenoid seats.
3. Rinse off the solenoid to remove debris.
4. Check condition of solenoid O-ring.
5. Replace solenoid if necessary with part number applicable to your particular model.

<u>Model</u>	<u>Solenoid P/N</u>	<u>Diaphragm P/N</u>
CP-075 or-100	208484	209391
EV-100 EV-100F	407200	407303

CP-075
CP-100
VALVE PARTS



SOLENOID



BONNET SCREWS



BLEED SCREW

BLEED PORT



BONNET



DIAPHRAGM KIT
•Spring



•Diaphragm*

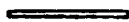

•Body Seal*

*May be combined as one piece.

BLEED PORT

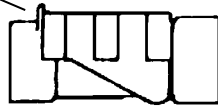

VALVE BODY

If you need further assistance, or other advice on installation, contact our customer service team at 1-800-RAIN-BIRD.

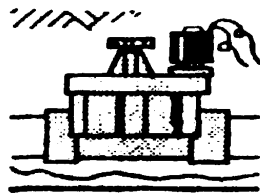

EV-100

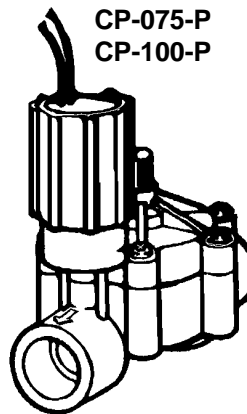

CP-075-P
CP-100-P

INSURE QUALITY - USE ONLY GENUINE RAIN BIRD PARTS

Disassembling the valve for cleaning or part replacement — Disassembly Procedure B

A removable actuator makes piston-type valves easy to access for maintenance. Should you need to clean the valve or replace a part, the actuator is removable following these procedures:

1. Shut off the water at the master shut off valve.
2. Using a pair of adjustable pliers clamped in the area of the valve indicated in the illustration (next page), unscrew the actuator counterclockwise.
3. To inspect the piston seals or replace the piston, gently pull piston from the bottom to pull it out of valve.
4. To remove solenoid, hold gray flow ring and twist counter-clockwise to unscrew.

To reassemble the valve actuator assembly, screw it into the valve body in a clockwise direction until the actuator body contacts the valve body. **Caution:** Do not over tighten as this may cause damage to the actuator. Do not use any pipe dope or tape on the actuator threads. The bleed ports (holes) just above the threads can become clogged and prevent operation.

Two types of Repair kits are available, the SRK-1 Solenoid Replacement Kit and the PRK-100 Piston Replacement Kit.

<u>Ref.</u>	<u>Part Description</u>	<u>Part No.</u>
1	Solenoid Assembly	(SRK-1) B40602
2	O-Ring	
3	Piston Repair Kit (Santoprene)	(PRK-100) B40642
4	Piston	
5	Piston Spring	
	Piston Retainer	
	Piston Sleeve	
6	Filter	
7	Upper Bonnet O-Ring	
8	Lower Bonnet O-Ring	
9	Cap, Cover & Piston Assembly	210067
10	Cap & Cover Assembly	203661
11	Gasket	
12	Piston Vacuum Breaker	
13	Sealing Washer	
14	Body	

Please see the parts diagram on the next page.

Parts and Repair Information

A variety of parts and parts assemblies are available for Rain Bird valves. If your local Rain Bird dealer does not carry the part you need, ask if it can be ordered, or call our toll free Technical Services hotline for dealer referral or factory direct ordering information. If you are unsure of the model you have or need help in identifying or finding a part, the Technicians on our toll-free line are eager to assist you. A parts breakdown on your particular model is available upon request.

If you have any questions about the information in this packet or about any Rain Bird products, call us toll free for fast and knowledgeable service at: 1-800-RAIN-BIRD.

Customer Support Center: 6640 S. Bonney Ave., Tucson, AZ 85706
FAX: (520) 434-6289

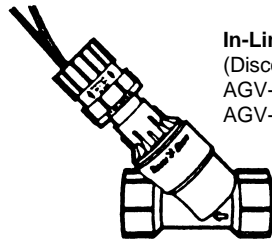

In-Line Valves
 (Discontinued)
 AGV-075-P
 AGV-100-P

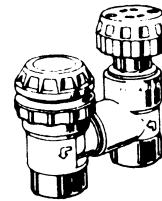

PAS-100
Manual
Anti-Siphon
Valve

Anti-Siphon Valve
With Backflow Prevention
 APAS-075-P
 APAS-100-P

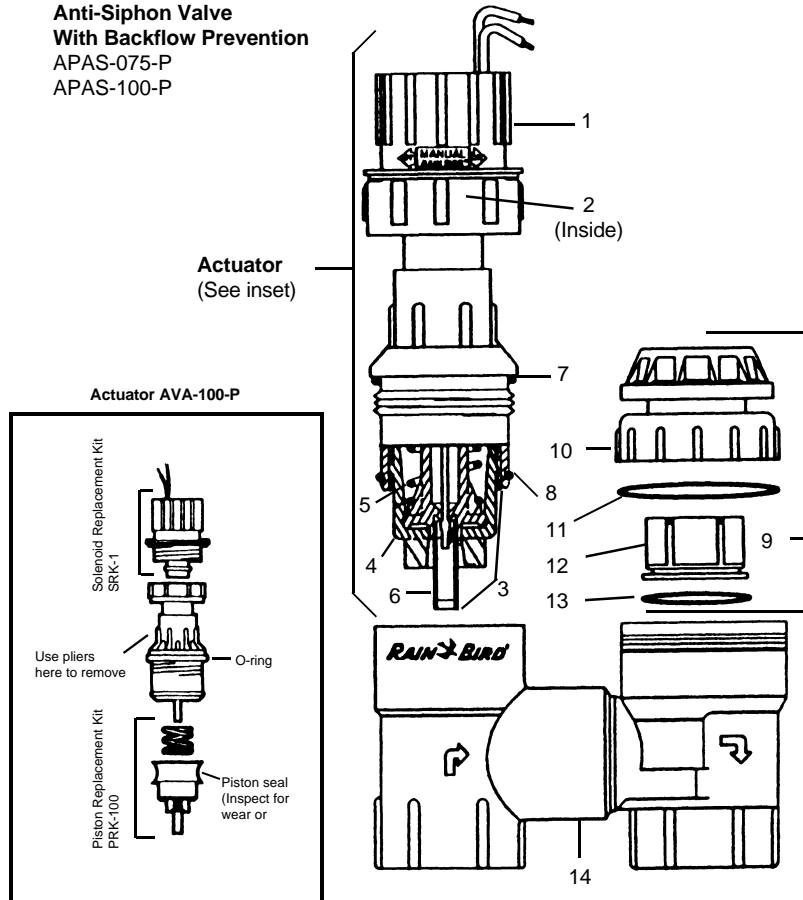

INSURE QUALITY - USE ONLY GENUINE RAIN BIRD PARTS