



**.5-3" (15-80mm)
PEC ECCENTRIC PLUG VALVES
TECHNICAL SPECIFICATIONS**



Flanged Construction .5-3" (15-80mm)

Materials of Construction

Item	Description	Material
A1	Body	Cast Iron, ASTM A126, Class B
		Acid Resistant Bronze, ASTM B427 Alloy C90800
		Carbon Steel, ASTM A216, Grade WCB
		316 Stainless Steel, ASTM A743, Grade CF-8M
		Alloy 20
		Hastelloy C
	Monel	
A2	Bearing	316L Stainless Steel, Sintered Stainless Steel
A4	Bearing	316L Stainless Steel, Sintered Stainless Steel
A5	Gasket	Non-asbestos filler in Styrene-Butadiene Rubber binder
A6	Bonnet	Same material as body
A7	Stud, Plug	Carbon Steel, Grade 2, Zinc Plated
A8	Plug	Metal (same metal as valve body except Cast Iron and Carbon Steel which have 316 Stainless Steel Plug)
		Rubber Faced (same metal as valve body except Carbon Steel which has 316 Stainless Steel Plug) See plug facing materials listed below.
	Plug Facing	CR Chloroprene (RS16* and RS17)
		NBR Acrylonitrile-Butadiene (RS24* and RS26*)
		NRH Hard Natural Rubber (RS53)
		CIIR Chloro-Isobutene Isoprene (RS55*)
		NRCR Hard Rubber with Chloroprene Overlay (RS53 with RS17)
		CSM Chloro-Sulfonyl Polyethylene (RS47*)
		FKM Fluoro Rubber (RS48*)
		NBRD Acrylonitrile-Butadiene (RS26)
3" NRCR Plugs and CIS bodies only	CR Chloroprene (RS17)	
A9	Bonnet Screws	Carbon Steel, Grade 2, Zinc Plated (CI, ABZ, NR Body Materials)
		Carbon Steel, Grade 5, Zinc Plated (CS Body Material)
		18-8 Stainless Steel (S2, AA, HC, ML Body Materials)
A10	Felt Washer (Lever, MNA and NT actuators only)	SAE F-7
A11	Stem Seal	NBR Acrylonitrile-Butadiene, PTFE and NBR Rubber
		FKM Fluorinated Hydrocarbon, PTFE and FKM Rubber
		PTFE
		Graphoil (GTN)
A12	U-Ring Filler	FKM and NBR only

*Indicates transfer molded process

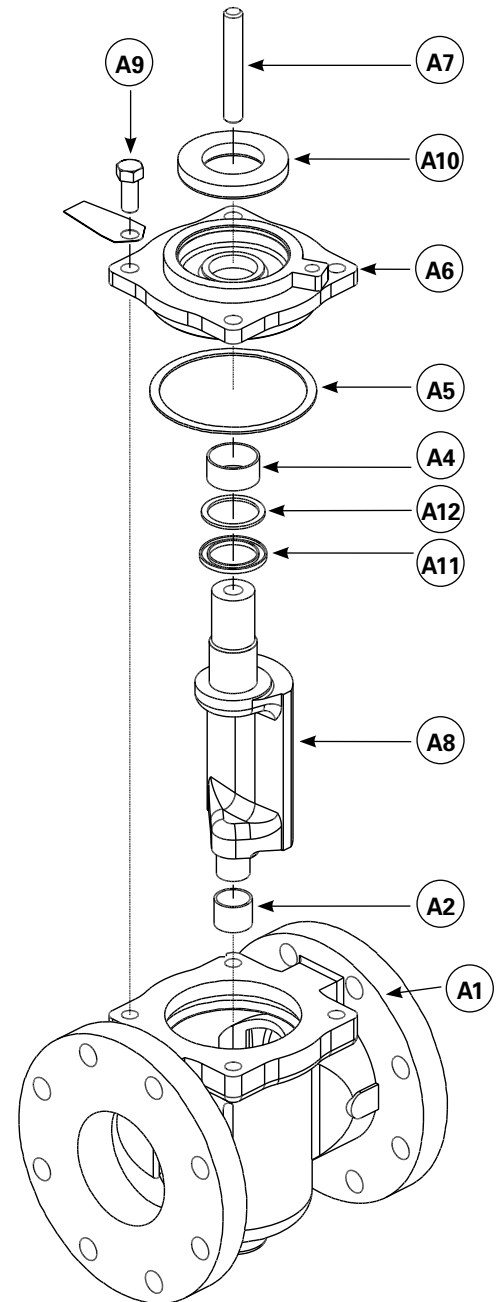

Valve Selection

Cv/Kv Values

Valve Size	Port Area %	Cv/Kv
.5" (15mm)	204	10/9
.75" (20mm)	117	20/17
1" (25mm)	72	33/29
1.25" (32mm)	115	74/64
1.5" (40mm)	84	74/64
2" (50mm)	91	148/128
2.5" (65mm)	99	236/204
3" (80mm)	80	330/285

*Cv Values = Flow in GPM of water at 1 psi pressure drop.
Kv Values = Flow in m³/hr of water at 100 kPa pressure drop.

Note: Cv/Kv Values will be slightly higher for valves with threaded end and for metal-to-metal seated valves. Sizing data is based on discharge into conduit rather than atmosphere.

Applicable Standards

ANSI flange drilling conforms to ANSI B16.1, Class 125 and ANSI B16.5, Class 150.

ANSI threaded end connections conform to the NPT requirements of ANSI B1.20.1.

Mechanical-joint end connections conform to ANSI/AWWA C111/A21.11.

Grooved joint end connections conform to ANSI/AWWA C606.

Metric 10 bar flange drilling conforms to the NP 10 requirements of International Standard ISO 2084, to the 10 bar requirements of British Standard 4504, and to the NP 10 requirements of German Standard DIN 2532.

Metric 16 bar flange drilling conforms to the NP 16 requirements of International Standard ISO 2084, to the 16 bar requirements of British Standard 4504, and to the NP 16 requirement of German Standard DIN 2533.

DIN parallel threaded end connections conform to German Standard DIN 259.

British Table D flange drilling and Table E flange drilling conform to British Standard BS 10.

British tapered thread end connections conform to British Standard BS 21.

Japanese 10 bar flange drilling conforms to Japanese Industrial Standard JIS B 0203.

Japanese tapered threaded end connections conform to Japanese Industrial Standard JIS B 0203.

French tapered threaded end connections conform to French Standard NFPN E 03-004.

Flow Characteristic

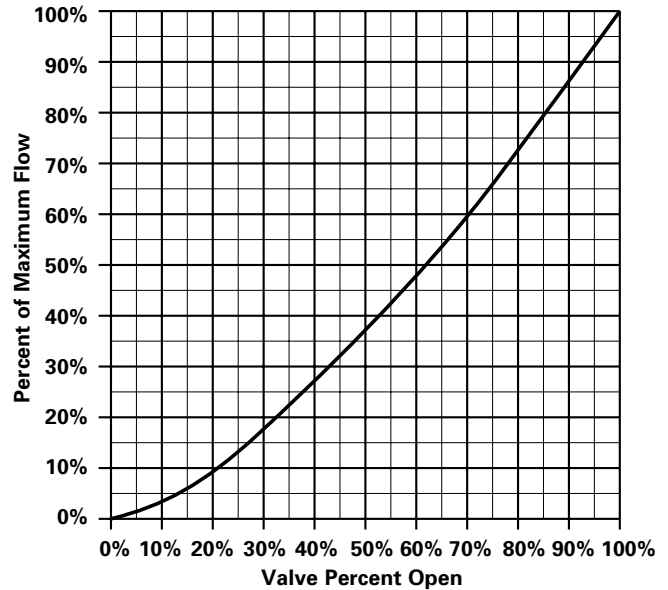

Pressure Ratings

C.W.P. non-shock working pressure ratings are:

Cast Iron	175 psi (1207 kPa)
Acid Resisting Bronze	200 psi (1379 kPa)
Aluminum	150 psi (1034 kPa)
Carbon Steel**	285 psi (1965 kPa)
Stainless Steel** and Other Alloys	275 psi (1896 kPa)
Hard and Soft Rubber Lined Cast Iron* Body	175 psi (1207 kPa)

*Cast Iron conforms to ANSI B16.1 Class 125 Hydrostatic Test.

**Carbon Steel and 316 Stainless Steel conform to ANSI B16.5 Class 150.

Valve Weights

Valve Size	Body Material lb (kg)									
	Cast Iron		Bronze, Acid Bronze		Aluminum		Carbon Steel		Stainless Steel	
	Flanged	Threaded	Flanged	Threaded	Flanged	Threaded	Flanged	Threaded	Flanged	Threaded
.5" (15mm)	8 (4)	5 (2)	8 (4)	5 (2)	4 (2)	3 (1)	7 (3)	5 (2)	7 (3)	5 (2)
.75" (20mm)	8 (4)	5 (2)	8 (4)	5 (2)	4 (2)	3 (1)	8 (4)	5 (2)	8 (4)	5 (2)
1" (25mm)	8 (4)	5 (2)	9 (4)	5 (2)	4 (2)	3 (1)	9 (4)	5 (2)	9 (4)	5 (2)
1.25" (32mm)	12 (5)	8 (4)	13 (6)	9 (4)	6 (3)	4 (2)	11 (5)	8 (4)	11 (5)	8 (4)
1.5" (40mm)	13 (6)	8 (4)	14 (6)	9 (4)	6 (3)	4 (2)	12 (5)	8 (4)	12 (5)	8 (4)
2" (50mm)	20 (9)	12 (5)	23 (10)	13 (6)	10 (5)	7 (3)	21 (10)	12 (5)	21 (10)	12 (5)
2.5" (65mm)	29 (13)	19 (9)	34 (15)	20 (9)	14 (6)	10 (5)	32 (15)	19 (9)	32 (15)	19 (9)
3" (80mm)	42 (19)	31 (14)	45 (20)	32 (15)	21 (10)	16 (7)	45 (20)	31 (14)	45 (20)	31 (14)

Note: Weight includes levers. Weight added for adapters: 1 lb. /5 kg

Valve Sizing

Flow Charts

Valve Fully Open

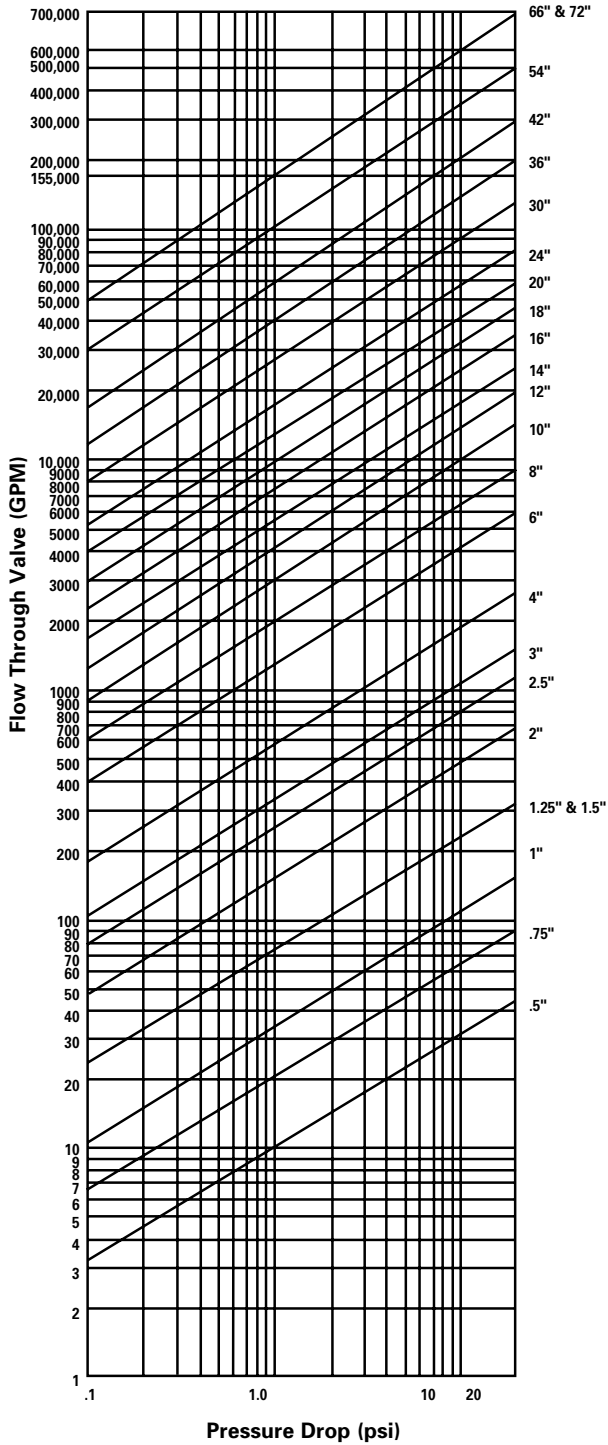

Valve Fully Open — Metric

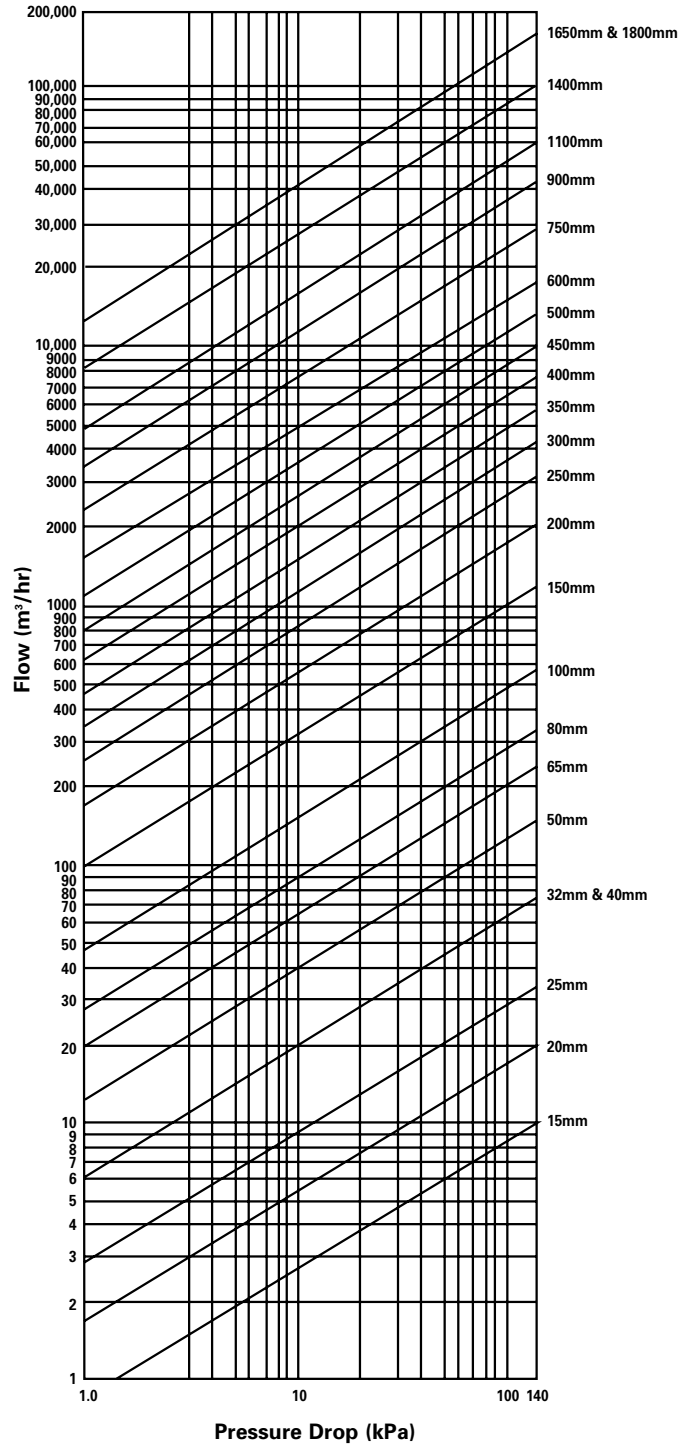

Installation Instructions

The type of materials carried in the pipeline and the location of the valve determine the correct installation procedure:

Liquids and Gases

1. Before installation, remove foreign material such as weld spatter, oil, grease, and dirt from the valve and pipeline.
2. Install the valve as shown in Figure 1.
3. Ensure the valve and flanges are concentric to ensure proper flange sealing.
4. Tighten the flange bolts or studs in a criss-cross pattern.

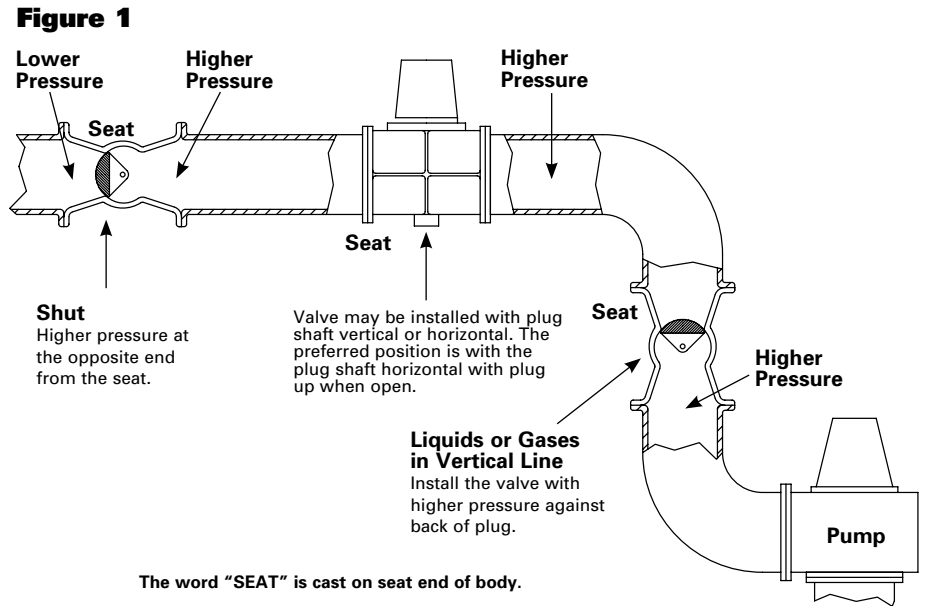

Suspended Solids

If the pipeline carries suspended solids such as paper stock of 2% or higher consistency, mining slurry, or raw sewage:

Figure 2

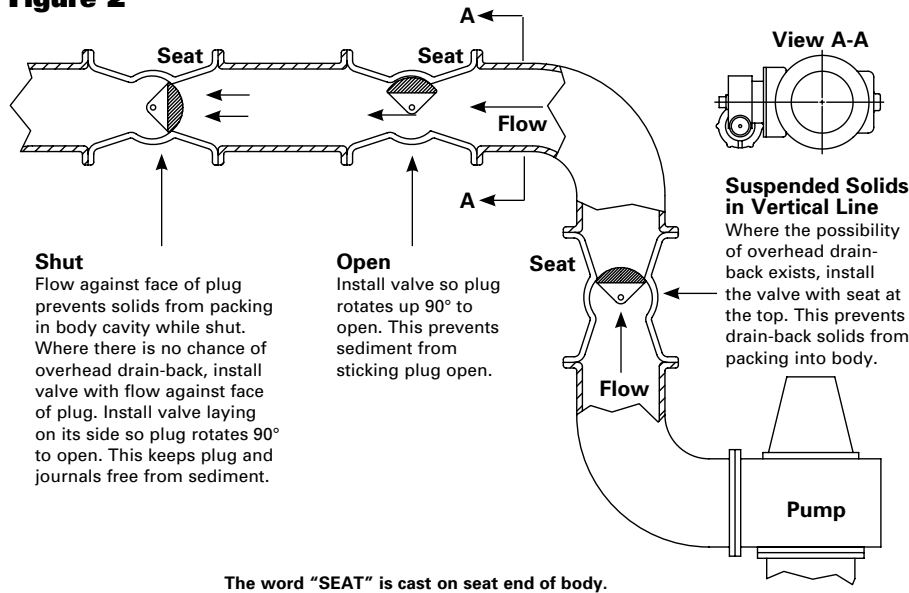

1. Before installation, remove foreign material such as weld spatter, oil, grease, and dirt from the valve and pipeline.
2. Install the valve as shown in Figure 2.
 - A. In horizontal pipelines install valve so plug is horizontal and rotates upward as valve opens.
 - B. For vertical pipelines, install valve with the end marked "Seat" at top of valve.
3. Tighten the flange bolts or studs in a criss-cross pattern.
4. Ensure the valve and flanges are concentric to ensure proper flange sealing.

Ordering

To order, simply complete the valve order code from the information shown.

Valve Style

Give valve style code as follows:

PEC = Eccentric Plug

Valve Size

Give valve size code as follows:

.5	=	.5"	(15mm)	1.5	=	1.5"	(40mm)
.75	=	.75"	(20mm)	2	=	2"	(50mm)
1	=	1"	(25mm)	2.5	=	2.5"	(65mm)
1.25	=	1.25"	(32mm)	3	=	3"	(80mm)

End Connection

F1	=	Flanged, ANSI Class 125/150 (except .5–1.5" (15–40mm) Cast Iron)
F110	=	Flanged, Class 150 DIN 10 or BS4504/10
F116	=	Flanged, Class 150 DIN 16 or BS4504/16
T1	=	Threaded, ANSI Class 150
F1D	=	Flanged, Class 150 BS Table D Drilling
F1E	=	Flanged, Class 150 BS Table E Drilling
F1J1	=	Flanged, Class 150 JIS 10 Drilling
GS	=	DIN Threaded (Parallel)
HS	=	BS Threaded (Taper)
JS	=	JIS Threaded (Taper)
KS	=	GAZ
MJ	=	Mechanical-Joint (3" (80mm) Cast Iron only)
V7	=	Grooved Ends Style 77 (.5–3" (20–80mm) Cast Iron only) per AWWA C606-97, Table 4
VF	=	Flexible Grooved Ends Style 31 (3" (80mm) Cast Iron only) per AWWA C606-97, Table 2
VR	=	Rigid Grooved Ends Style 31 (3" (80mm) Cast Iron only) per AWWA C606-97, Table 3

Body Material

Give body material code as follows:

CI	=	Cast Iron
CIH	=	Cast Iron, Hard Rubber Lined — 3" (80mm) Flanged only
CIN	=	Cast Iron, Nickel Welded Seat (3" only)
CIS	=	Cast Iron, Soft Rubber Lined — with T Packing and CR Plug Facing 3" (80mm) Flanged only
DI	=	Ductile Iron
DIN	=	Ductile Iron, Nickel Welded Seat (3" only)
DIS	=	Ductile Iron, Soft Rubber Lined (3" Flanged Only)
ABZ	=	Acid Bronze
CS	=	Carbon Steel (except .5–1.5" (15–40mm) Flanged) Nickel Seat on 2–3" (50–80mm) Valve
S2	=	316 Stainless Steel
AA	=	Alloy 20
HC	=	Hastelloy C
ML	=	Monel

Packing

Give packing code as follows:

NBR	=	Acrylonitrile-Butadiene Reinforced filler in a PTFE U-ring .5–3" (15–80mm) all resilient faced plugs except FKM and except 3" with CIS body material. -20 to 250° F (-29 to 121° C)
FKM	=	Fluorinated Hydrocarbon filler in a PTFE U-ring .5–3" (15–80mm) all metal and FKM plugs -20 to 450° F (-29 to 232° C) and CIIR plugs -20 to 250° F (-29 to 121° C)
T	=	Solid PTFE .5–3" (15–80mm) all metal plugs and 3" (80mm) CIH and CIS rubber lined valves -20 to 450° F (-29 to 232° C)

Plug Facing

Give plug facing code as follows:

M	=	Metal (same metal as valve body except CI and CS which have a Stainless Steel plug)
CR	=	Chloroprene (RS16) -20 to 180° F (-29 to 83° C)
NBR	=	Acrylonitrile-Butadiene (RS24) -20 to 180° F (-29 to 83° C)
NBRD	=	Acrylonitrile-Butadiene (RS26) -20 to 180° F (-29 to 83° C)
NRH	=	Hard Natural Rubber (RS53) -20 to 180° F (-29 to 83° C)
CIIR	=	Chloro-Isobutene Isoprene (RS55) -20 to 250° F (-29 to 121° C)
NRRCR	=	Hard Rubber with Chloroprene Overlay Use on CIH body only -20 to 180° F (-29 to 83° C)
CSM	=	Chloro-Sulfonyl Polyethylene (RS47) -20 to 200° F (-29 to 94° C)
FKM	=	Fluoro Rubber -20 to 450° F (-29 to 232° C) used with FKM or T packing only.
EPDM	=	Terpolymer of Ethylene Propylene & A Diene -20 to 250° F (-29 to 121° C)

Options

Give options codes as follows:

BV1	=	Balancing Valve with 1/8" air valve fittings
BV2	=	Balancing Valve with 1/8" quick disconnect couplings
DST	=	Dry Seat Test
PD	=	1/8" Pipe Tap Downstream
PU	=	1/8" Pipe Tap Upstream
PDU	=	1/8" Pipe Tap Upstream & Downstream
S2	=	Stainless Steel Plug
GE	=	Grit Excluders
GR	=	Grease Fittings in Body

Ordering Example:

PEC,2,F1,CI,NBR,CR,S2*PR-R1A-PC4

Note:

The limiting factor in valve selection is the lowest temperature limit of the packing or plug facing.

Manual Actuators

Pressure Ratings

Direct shutoff pressure differentials for lever, nut and adapter actuated valves must not exceed 150 psi (1030 kPa). Reverse shutoff differentials must not exceed 25 psi (170 kPa). If valves must seal higher reverse pressure, use handwheel actuators.

Lever (LV)

.5–3" (15–80mm) valve design includes a bolted-on, non-removable lever. To order, add code LV to basic valve code.

Ordering Example:
PEC,2,F1,CI,NBR,CR*LV

Adjustable Memory Stop

All .5–3" (15–80mm) lever actuated valves are furnished with an adjustable, open position memory stop as standard. With the stop ring adjusted to the desired open position, the valve can be closed and reopened to the same position. This feature makes the valve ideal for air conditioning balancing service. Valves with resilient seats provide double-duty on this application by combining balancing and shutoff in a single valve.

Stainless Steel Bolting — Lever Actuated Valves

Includes stainless steel spring, stud, nut, washer and bonnet bolts. To order, add SB18 for 18-8 stainless steel or SB16 for 316 stainless steel after the actuator order codes

Ordering Example:
PEC,2,F1,CI,NBR,CR,S2*LV,SB18

Adapter for Handles (HLA)

Furnished as standard on .5–3" (15–80mm) valves. Must be ordered to use LVR Removable Lever or CH Chain Handle. To order, add code HLA to basic valve code.

Ordering Example:
PEC,2,F1,CI,NBR,CR*HLA

Removable Lever (LVR)

For use with HLA Adapter. Removable levers must be ordered separately.

Order Code	Size
ACC*LVR103	.5–2" (15–50mm)
ACC*LVR105	2.5–3" (65–80mm)

Ordering Example:
ACC*LVR103

MNA Adapter for Lever Actuated Valves

The MNA adapter is required in order to use Floor Boxes (FB), Valves Boxes (VB), Extension Fittings (EF), Tee Wrenches (WRT) and Extended Nut (ENLV). To order, add MNA to basic valve code.

Ordering Example:
PEC,2,F1,CI,NBR,CR*MNA



Chain Handle (CH)

For use with HLA Adapter. Chain Handle must be ordered separately by giving code ACC*CH followed by a dash and valve size.

Order Code	Size
ACC*CH-.5	.5" (15mm)
ACC*CH-.75	.75" (20mm)
ACC*CH-1	1" (25mm)
ACC*CH-1.25	1.25" (30mm)
ACC*CH-1.5	1.5" (40mm)
ACC*CH-2	2" (50mm)
ACC*CH-2.5	2.5" (65mm)
ACC*CH-3	3" (80mm)

Ordering Example:
ACC*CH-2

Chain for Chain Handle (CN)

Order as a separate item by giving code ACC*CN101. Specify number of feet required and number of pieces.

Ordering Example:
ACC*CN101
Chain 1 piece 10 feet long

Accessories — Manual Actuators

EF Extension for Lever Actuated Valves

Includes extension pipe, bearing plate and couplings. Valves for use with EF Extensions must be ordered with MNA adapters. Order Extension Assembly as a separate item by giving code ACC*EF followed by a dash and valve size. Specify length from centerline of valve to bottom of bearing plate. When ordering for use with FS101 Floor Stand, give dimension from centerline of valve to base of floor stand.

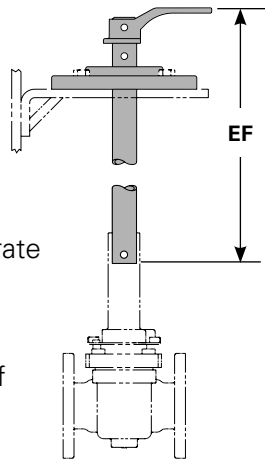

Ordering Example:

ACC*EF-3

Centerline of valve to bottom of bearing plate
110 inches (2795mm)

FS101 Floor Stand for Lever Actuated Valves

Includes floor stand only. For extension pipe and fittings, order EF Extension Assembly. Lever actuated valves for use with EF Extension and FS101 Floor Stand must be ordered with adapters. Order floor stands as a separate item.

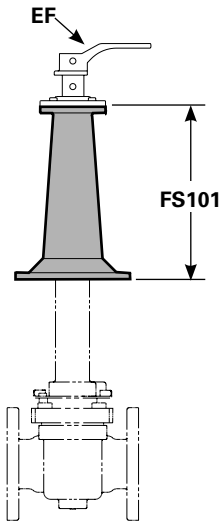

Ordering Example:

ACC*FS101

FB Floor Box for Lever Actuated Valves

Includes floor box and cover only. Can be used with valves having operating nut mounted on the valve or extended with top of nut 2" (50mm) from top of floor box. All valves for use with floor boxes are Tee Wrench actuated (order separately). Order extended operating nuts (ENLV) separately. Floor box requires MNA adapters (order separately). Order floor boxes separately. Specify ACC*FB and depth of floor box in 1" (25mm) increments from 6–18" (150–455mm). Standard depth is 6" (150mm).

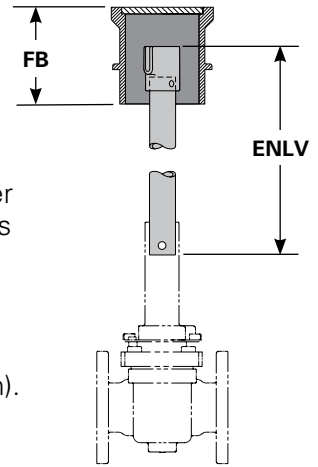

Ordering Example:

ACC*FB6

ENLV Extended Nut for Lever Actuated Valves

For use with ACC*FB Floor Box or VB Valve Box. Includes operating nut, couplings and pipe. Valves for use with ENLV Extended Nut must be ordered with MNA adapters. All valves for use with ENLV are Tee Wrench activated (order separately). Order as a separate item by giving ACC*ENLV followed by a dash and valve size. Give required length from centerline of valve to top of nut. Note dimensions in table.

Valve Size	Minimum Dimension C/L of Valve to Top of Nut
.5–1" (15–25mm)	9.25" (235mm)
1.25–1.5" (32–40mm)	9.63" (245mm)
2" (50mm)	11.00" (280mm)
2.5" (65mm)	13.50" (345mm)
3" (80mm)	14.13" (360mm)

Ordering Example:

ACC*ENLV-3

Centerline of valve to top of valve nut 126 inches (3200mm)

WRT Tee Wrench

Valves for Tee Wrench operation must be ordered with MNA Adapter or ENLV Extended Nut. To order Tee Wrenches, list order code per table below.

Wrench Length	Valve Size		
	.5–1.5" (15–40mm)	2" (50mm)	2.5–3" (65–80mm)
4 Feet (120cm) (Standard)	ACC*WRT250-A	ACC*WRT250-B	ACC*WRT250-C
5 Feet (150cm)	ACC*WRT251-A	ACC*WRT251-B	ACC*WRT251-C
6 Feet (185cm)	ACC*WRT252-A	ACC*WRT252-B	ACC*WRT252-C
7 Feet (215cm)	ACC*WRT253-A	ACC*WRT253-B	ACC*WRT253-C
8 Feet (245cm)	ACC*WRT254-A	ACC*WRT254-B	ACC*WRT254-C

Ordering Example:

ACC*WRT250-A

Accessories — Manual Actuators

VB Valve Box for Lever Actuated Valves

Valve boxes are for use with lever actuated valves. Includes valve box and cover only. Can be used with valves having operating nut mounted on the valve or extended with top of nut 6" (150mm) from top of valve box. All valves for use with valve boxes are Tee Wrench actuated (order separately). Order extended operating nuts (ENLV) separately. Valve box requires MNA adapters (order separately). To order valve boxes, list order code and specify valve centerline to top of valve box (grade). If an extension is required, add a dash and extension order code.

.5-3" (15-80mm) Valve Boxes

Valve Center Line to Top of Box (Grade)	Valve Box Order Code
18-24" 450-600mm	ACC*VB627
22-28" 550-700mm	ACC*VB628
24-30" 600-750mm	ACC*VB629
27-38" 680-960mm	ACC*VB630
39-60" 990-1500mm	ACC*VB631

Valve Box Extensions

Extension Length (Grade)	Quantity	Extension Order Code
	1	18A
	2	18B
18"	3	18C
460mm	4	18D
	5	18E

Ordering Example (without extension):

ACC*VB627

Valve centerline to top of box - 22 inches (560mm)

Ordering Example (with extension):

ACC*VB627-18A

Valve centerline to top of box - 40 inches (1015mm)

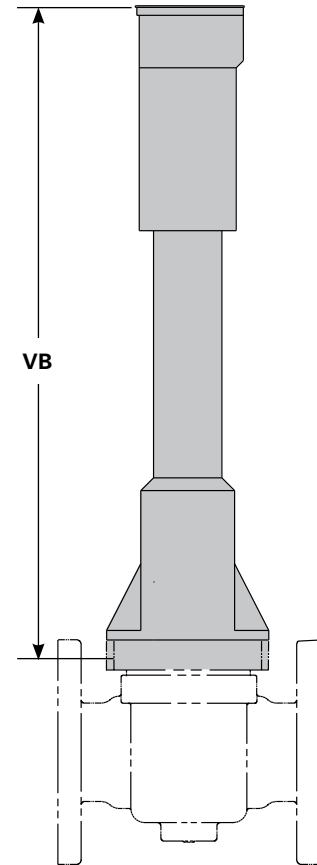

Handwheel and Chainwheel Actuators

Manual gear actuator housings are constructed of high strength metal and feature sintered bronze bearings on each end of the input shaft for durability and performance. The high strength gear provides strength for robust applications and a long service life without maintenance. All manual gear actuators feature external position indication and are available with safety lockout devices. Actuators for buried service are available as an option.



Compact Cylinder Actuators

Compact actuators are a versatile rack-and-pinion design and are available as double-acting or spring-return units. The compact, modular design allows the actuator to be mounted for a low profile assembly. Compact actuators are matched to each valve's torque requirements to ensure that the most economical valve and actuator package is specified.

Electric Motors

DeZURIK offers a variety of electric motor actuators on Eccentric Plug valves. When ordering, please specify valve function, installation location, line fluid, maximum fluid temperature, pipe connection, line size, normal and maximum working pressure, normal and maximum wide open valve flow, and flow range desired if throttling or modulating control.



Dimensions

Material Groups

Group 1	Cast Iron
Group 2	Carbon Steel 2-3" (50-80mm)
Group 3	Stainless Steel, Bronze, Alloys

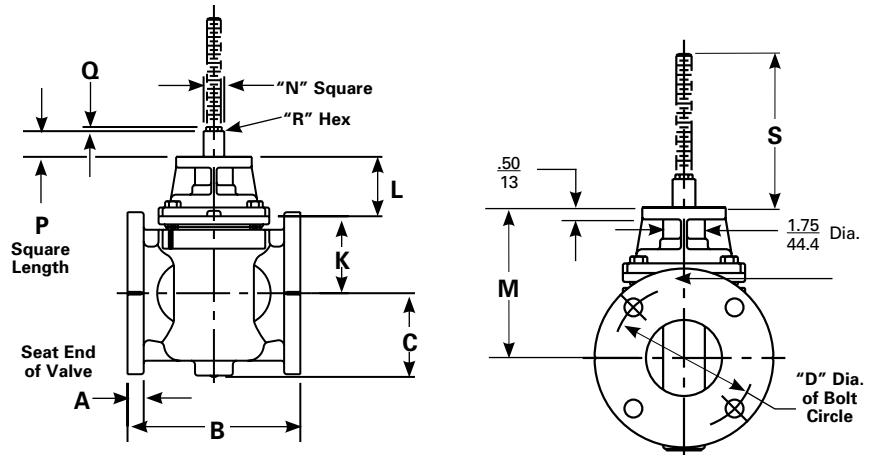

Basic Valve

Valve Size	A	B			C	D**	K	L	M	Square 1	Square 2	Square 3	Square 4	Q	R	S		
		Flanged Material Group 1 & 2*	Flanged Material Group 3	Threaded Material Group 1, 2 & 3						N x P	N x P	N x P	N x P			Power-Rac®	DR40	DR55 DR85
.5" 15mm	.44 11	4.12 105	4.12 105	3.12 79	1.69 43	2.38 60	1.72 44	2.38 60	4.10 104	.55x.55 14x14	.88x.69 22x17	.50x1.42 13x36	.63x.75 16x19	.21 5	.44 11	4.03 102	3.54 90	5.19 132
.75" 20mm	.44 11	4.12 105	4.12 105	3.12 79	1.69 43	2.75 70	1.72 44	2.38 60	4.10 104	.55x.55 14x14	.88x.69 22x17	.50x1.42 13x36	.63x.75 16x19	.21 5	.44 11	4.03 102	3.54 90	5.19 132
1" 25mm	.44 11	4.12 105	4.12 105	3.12 79	1.69 43	3.12 79	1.72 44	2.38 60	4.10 104	.55x.55 14x14	.88x.69 22x17	.50x1.42 13x36	.63x.75 16x19	.21 5	.44 11	4.03 102	3.54 90	5.19 132
1.25" 32mm	.56 14	4.38 111	4.38 111	4.50 114	2.12 54	3.50 89	2.12 54	2.38 60	4.44 113	.55x.55 14x14	.88x.69 22x17	.50x1.42 13x36	.63x.75 16x19	.21 5	.44 11	4.03 102	3.54 90	5.19 132
1.5" 40mm	.56 14	4.38 111	4.38 111	4.50 114	2.12 54	3.88 98	2.12 54	2.38 60	4.44 113	.55x.55 14x14	.88x.69 22x17	.50x1.42 13x36	.63x.75 16x19	.21 5	.44 11	4.03 102	3.54 90	5.19 132
2" 50mm	.62 16	7.00 178	5.50 140	5.25 133	2.50 64	4.75 121	2.53 64	2.38 60	4.91 125	.55x.55 14x14	.88x1.31 22x33	.50x1.42 13x36	.63x.73 16x19	.21 5	.44 11	4.03 102	3.54 90	5.19 132
2.5" 65mm	.69 18	7.50 191	6.50 165	6.25 159	3.12 79	5.50 140	3.03 77	2.75 70	5.78 147	.67x.54 17x14	.88x1.31 22x33	.63x.74 16x19	-	.26 7	.50 13	3.91 99	3.43 87	5.19 132
3" 80mm	.75 19	8.00 203	7.38 187	7.75 197	3.88 98	6.00 152	3.56 90	2.75 70	6.31 160	.67x.54 17x14	.88x1.31 22x33	.63x.74 16x19	-	.26 7	.50 13	4.03 102	-	5.29 134

Inches *Flanged cast iron valves are available in sizes 2, 2.5, and 3" only (50, 65 and 80mm).
 Millimeters **Dimension D is ANSI B16.1 Class 125 and ANSI B16.5 Class 150.

Dimensions

Lever

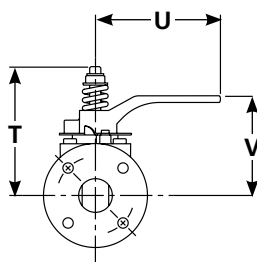

HLA Adapter w/Chain Handle

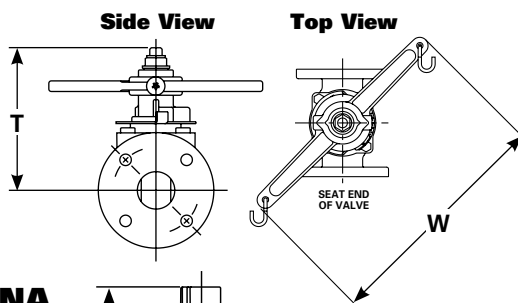

HLA Adapter

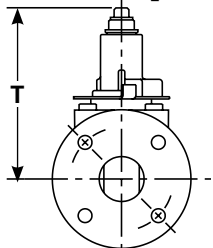

MNA Adapter

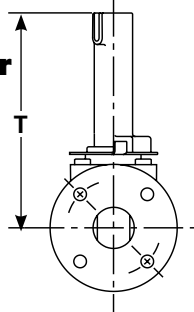

Manual Actuators

Valve Size	Dimensions					
	Lever	T		U	V	W
		HLA Adapter	MNA Adapter			
.5" 15mm	4.50 114	4.38 111	6.12 155	4.00 102	4.06 103	9.00 229
.75" 20mm	4.50 114	4.38 111	6.12 155	4.00 102	4.06 103	9.00 229
1" 25mm	4.50 114	4.38 111	6.12 155	4.00 102	4.06 103	9.00 229
1.25" 32mm	4.88 124	4.69 119	6.50 165	5.00 127	4.53 115	11.00 279
1.5" 40mm	4.88 124	4.69 119	6.50 165	5.00 127	4.53 115	11.00 279
2" 50mm	6.19 157	6.00 152	7.75 197	6.50 165	5.22 133	14.00 356
2.5" 65mm	7.00 178	7.00 178	9.50 241	7.50 191	5.69 145	14.50 368
3" 80mm	7.75 197	7.62 194	9.50 241	9.00 229	6.38 162	19.00 483

Sales and Service

For information about our worldwide locations, approvals, certifications and local representative:

Web Site: www.dezurik.com E-Mail: info@dezurik.com



250 Riverside Ave. N. Sartell, Minnesota 56377 • Phone: 320-259-2000 • Fax: 320-259-2227

DeZURIK reserves the right to incorporate our latest design and material changes without notice or obligation. Design features, materials of construction and dimensional data, as described in this bulletin, are provided for your information only and should not be relied upon unless confirmed in writing by DeZURIK. Certified drawings are available upon request.