

# FNW 9301

## HYDRANT ADAPTERS



### BRASS FEMALE ADAPTER

#### FEATURES

- Used to change the pipe size, reverse the sex of the fitting or change the thread type
- Fire hose Female by Female threaded connection
- Pin lug
- Washer seal on FNST end
- Thread seal on FNPT end



#### PART MATERIALS & QUANTITY

- Brass C38500 MOD1

#### REPLACEMENT BUNA GASKETS

Size	Part Number
1-1/2	FNW9300J
2-1/2	FNW9300L

**Note:** Only compatible with Female NST adapters

#### PRODUCT SPECIFICATIONS

PRODUCT CODE	DESCRIPTION	WEIGHT
FNW9301LL	2-1/2 FNST X 2-1/2 FNPT BRS PIN LU	3.825
FNW9301LM	2-1/2 FNST X 3 FNPT FEM SWVL ADPT	3.933

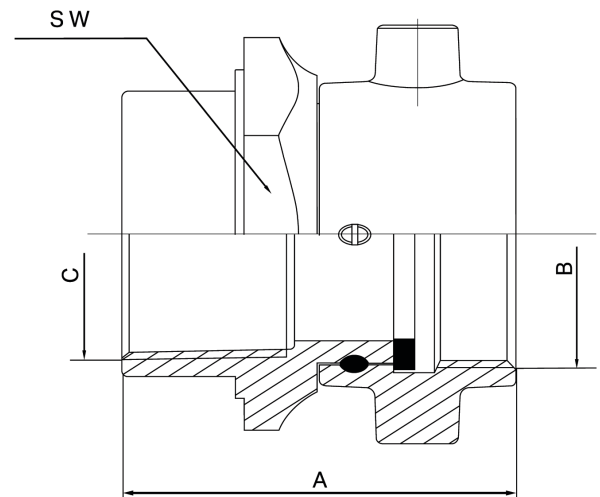

#### PARTS BREAKDOWN

PRODUCT CODE	A	B	C	SW	WASHER
FNW9301LL	2.88	2-1/2 FNST	2-1/2 FNPT	3.92	V
FNW9301LM	2.90	2-1/2 FNST	3 FNPT	4.53	V

**Note:** Tolerance: Cast Dim.: +/-0.03" Machining Dim.: +/-0.02"