



# Installation & Service Manual

**Models: SWR125, SWR150, SWR200, SWR285, SWR400, SWA150, SWA200, SWA285, SWA400 and SWA500**

**WARNING:** If the information in these instructions is not followed exactly, a fire or explosion may result causing property damage, personal injury or death.

-- Do not store or use gasoline or other flammable vapors and liquids in the vicinity of this or any other appliance.

**-- WHAT TO DO IF YOU SMELL GAS**

- Do not try to light any appliance.
- Do not touch any electrical switch; do not use any phone in your building.
- Immediately call your gas supplier from a near by phone. Follow the gas supplier's instructions.
- If you cannot reach your gas supplier, call the fire department.

-- Installation and service must be performed by a qualified installer, service agency, or the gas supplier.

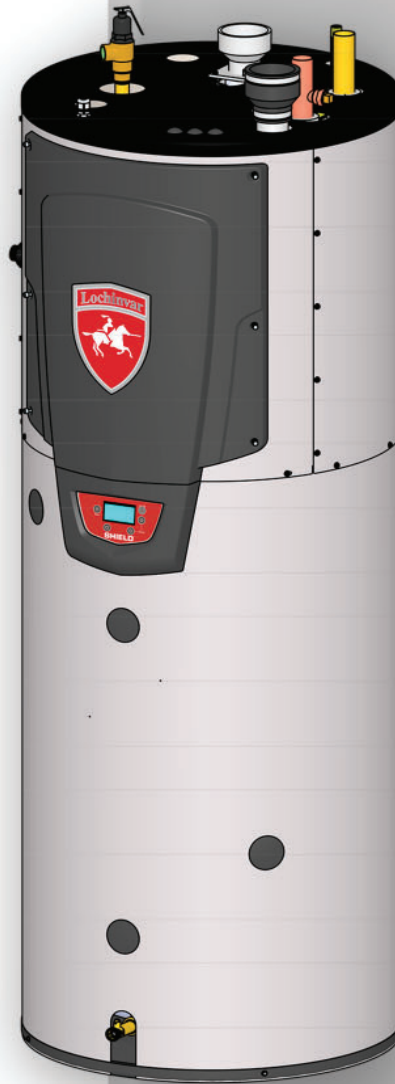

DIR #2000602769 00



**WARNING**

This manual must only be used by a qualified heating installer / service technician. Read all instructions in this manual before installing. Perform steps in the order given. Failure to comply could result in severe personal injury, death, or substantial property damage.

Save this manual for future reference.



# Contents

<b>PLEASE READ BEFORE PROCEEDING</b> .....	3
Hazard Definitions .....	3
<b>THE SHIELD -- HOW IT WORKS</b> .....	4-6
<b>RATINGS</b> .....	7
<b>1. DETERMINE WATER HEATER LOCATION</b>	
Closet and Alcove Installations .....	8
Provide Clearances .....	8
Flooring and Foundation .....	10
Remove Water Heater from Wood Pallet .....	10
Prevent Combustion Air Contamination .....	10
Using an Existing Vent System to Install a New Water Heater .....	11
Removing Water Heater From Existing Common Vent ..	11
Combustion & Ventilation Air Requirements .....	12-14
<b>2. GENERAL VENTING</b>	
Direct Venting Options .....	15
Install Vent and Combustion Air Piping .....	16
Requirements for Installation in Canada .....	17
Sizing .....	17
Min./Max. Combustion Air & Vent Piping Lengths .....	17
Materials .....	18
Optional Room Air .....	19
PVC/CPVC .....	20
Polypropylene .....	21
Stainless Steel Vent .....	22
<b>3. SIDEWALL DIRECT VENTING</b> .....	23-32
<b>4. VERTICAL DIRECT VENTING</b> .....	33-36
<b>5. SYSTEM PIPING</b>	
General Piping .....	37
Scalding .....	37
Water Chemistry .....	38
Piping Components .....	38
Piping Diagrams .....	39-41
<b>6. GAS CONNECTIONS</b>	
Connecting Gas Supply Piping .....	42
Natural Gas .....	43
Pipe Sizing for Natural Gas .....	43
Natural Gas Supply Pressure Requirements .....	43
Propane Gas .....	43
Pipe Sizing for Propane Gas .....	43
Propane Supply Pressure Requirements .....	43
Check Inlet Gas Supply .....	44-45
Gas Pressure .....	45
Gas Valve Replacement .....	45
<b>7. FIELD WIRING</b>	
Low Voltage Connections .....	46
Enable Switch .....	46
Louver Relay Output / Louver Proving Switch Input .....	46
Power Cord Connection .....	46
Runtime Contacts .....	46
Alarm Contacts .....	46
<b>8. CONDENSATE DISPOSAL</b>	
Condensate Drain .....	49
<b>9. START-UP</b>	
Check for Gas Leaks .....	50
Inspect/fill Condensate System .....	50
Final Checks Before Starting the Water Heater .....	51-54
Shield Control Module .....	55
Setup Wizard .....	56
<b>10. OPERATING INFORMATION</b>	
How the Water Heater Operates .....	57
Temperature Control .....	57
Protection Features .....	57
Water Heater Temperature Regulation .....	58
Adjustable Control Parameters .....	58
Installer Adjustable Parameters .....	59
General SubMenu .....	59-60
Service Mode .....	61
Building Management System (BMS) .....	61-62
<b>11. MAINTENANCE</b>	
Maintenance and Annual Startup .....	63
Address Reported Problems .....	64
Inspect Water Heater Interior .....	64
Clean Condensate Trap .....	64
Check All Piping for Leaks .....	64
Flue Vent System and Air Piping .....	64
Check Water System .....	64
Check Expansion Tank .....	65
Check Water Heater Relief Valve .....	65
Inspect Ignition & Flame Sense Electrodes .....	65
Check Ignition Ground Wiring .....	65
Check All Water Heating Wiring .....	65
Check Control Settings .....	65
Perform Startup & Checks .....	65
Check Burner Flames .....	66
Check Flame Signal .....	66
Review with Owner .....	66
Handling Ceramic Fiber Materials .....	66
Cleaning Heat Exchanger .....	66-67
Oiled Bearing Circulators .....	67
Magnesium Anode Rod Inspection .....	67
<b>12. TROUBLESHOOTING</b>	
Before Troubleshooting .....	68
Troubleshooting Chart - No Display .....	69
Checking Temperature Sensors .....	70
Troubleshooting Chart - Noisy System .....	71
Troubleshooting Chart - Fault Messages Displayed .....	72-77
Combustion Analysis Procedure .....	78
Gas Valve Adjustment Procedure .....	79
<b>13. DIAGRAMS</b>	
Ladder Diagram .....	80
Wiring Diagram .....	81

## Please read before proceeding

### Hazard definitions

The following defined terms are used throughout this manual to bring attention to the presence of hazards of various risk levels or to important information concerning the life of the product.

#### ⚠ DANGER

DANGER indicates an imminently hazardous situation which, if not avoided, will result in death or serious injury.

#### ⚠ WARNING

WARNING indicates a potentially hazardous situation which, if not avoided, could result in death or serious injury.

#### ⚠ CAUTION

CAUTION indicates a potentially hazardous situation which, if not avoided, may result in minor or moderate injury.

#### CAUTION

CAUTION used without the safety alert symbol indicates a potentially hazardous situation which, if not avoided, may result in property damage.

#### NOTICE

NOTICE indicates special instructions on installation, operation, or maintenance that are important but not related to personal injury or property damage.

#### ⚠ WARNING

**Installer** – Read all instructions, in this manual before installing. Perform steps in the order given.

Have this water heater serviced/inspected by a qualified service technician, at least annually.

Failure to comply with the above could result in severe personal injury, death or substantial property damage.

#### NOTICE

When calling or writing about the water heater – Please have the water heater model and serial number from the water heater rating plate.

Consider piping and installation when determining water heater location.

Any claims for damage or shortage in shipment must be filed immediately against the transportation company by the consignee.

Factory warranty (shipped with unit) does not apply to units improperly installed or improperly operated.

#### ⚠ WARNING

Failure to adhere to the guidelines on this page can result in severe personal injury, death, or substantial property damage.

#### ⚠ WARNING

DO NOT install units in rooms or environments that contain corrosive contaminants (see Table 1A on page 10). Failure to comply could result in severe personal injury, death, or substantial property damage.

### When servicing the water heater –

- To avoid electric shock, disconnect electrical supply before performing maintenance.
- To avoid severe burns, allow the water heater to cool before performing maintenance.

#### ⚠ WARNING

If the information in these instructions is not followed exactly, a fire or explosion may result causing property damage, personal injury or death

-- Do not store or use gasoline or other flammable vapors and liquids in the vicinity of this or any other appliance.

#### -- WHAT TO DO IF YOU SMELL GAS

- Do not try to light any appliance.
  - Do not touch any electrical switch; do not use any phone in your building.
  - Immediately call your gas supplier from a near by phone. Follow the gas supplier's instructions.
  - If you cannot reach your gas supplier, call the fire department.
- Installation and service must be performed by a qualified installer, service agency, or the gas supplier.

### Water heater operation –

- Do not block flow of combustion or ventilation air to the water heater.
- Should overheating occur or gas supply fail to shut off, do not turn off or disconnect electrical supply to circulator. Instead, shut off the gas supply at a location external to the appliance.
- Do not use this water heater if any part has been under water. The possible damage to a flooded appliance can be extensive and present numerous safety hazards. Any appliance that has been under water must be replaced.

## The Shield - How it works...

- 1. Access cover - front**  
Provides access to the gas train, heat exchanger and controls.
- 2. Air intake adapter**  
Allows for the connection of the PVC air intake pipe to the water heater.
- 3. Air pressure switch**  
The air pressure switch detects blocked inlet conditions.
- 4. Burner door temperature switch (285 --500 Models Only)**  
An electrical switch designed to shut down water heater operation in the event the combustion chamber access cover exceeds 500°F (260°C). This switch may only be reset by a qualified service technician AFTER the underlying cause has been identified and corrected. Check the integrity of the front refractory on the inside of the combustion chamber access cover if the switch opens.
- 5. Blower**  
The blower pulls in air and gas through the venturi (item 32). Air and gas mix inside the blower and are pushed into the burner, where they burn inside the combustion chamber.
- 6. Burner (not shown)**  
Made with metal fiber and stainless steel construction, the burner uses pre-mixed air and gas and provides a 5 to 1 firing rate.
- 7. Condensate drain connection**  
Connects the condensate drain line to 1/2" PVC.
- 8. Electronic Control Module**  
The electronic control responds to internal and external signals and controls the blower, gas valve, and pump to meet the demand.
- 9. Electronic display**  
The electronic display consists of 4 buttons, and a liquid crystal display. The display is used to make adjustments and read water heater status.
- 10. Flame inspection window (not shown)**  
The quartz glass window provides a view of the burner surface and flame.
- 11. Flame sensor**  
Used by the control module to detect the presence of burner flame.
- 12. Flue gas sensor (not shown)**  
This sensor monitors the flue gas exit temperature. The control module will modulate and shut down the water heater if the flue gas temperature gets too hot. This protects the flue pipe from overheating.
- 13. Gas connection pipe**  
Threaded pipe connection, either 1/2", 3/4", or 1", depending on the model. This pipe should be connected to the incoming gas supply for the purpose of delivering gas to the water heater.
- 14. Gas shutoff switch**  
An electrical switch designed to cut power from the gas valve to prevent gas flow to the burner.
- 15. Gas shutoff valve (400 -- 500 Models Only)**  
Manual valve used to isolate the gas valve from the gas supply.
- 16. Gas valve**  
The gas valve senses the negative pressure created by the blower, allowing gas to flow only if the gas valve is powered and combustion air is flowing.
- 17. Heat exchanger access cover**  
Allows access to the combustion side of the heat exchanger coils.
- 18. Heat exchanger inlet temperature sensor**  
This sensor monitors the inlet water temperature to the heat exchanger.
- 19. Heat exchanger outlet temperature sensor (not shown)**  
This sensor monitors heat exchanger outlet water temperature.
- 20. Ignition electrode**  
Provides direct spark for igniting the burner.
- 21. Line voltage junction box**  
The junction box contains the connection points for the line voltage power.
- 22. Low voltage connection board**  
The connection board is used to connect external low voltage devices.
- 23. Low voltage wiring connections (plugs)**  
Conduit entryway for the low voltage connection board.
- 24. Power cord (not shown)**  
The power cord allows for quick connection to 120V supply.
- 25. Pump**  
Circulates water between the tank and the heat exchanger.
- 26. Pump relay**  
Switches power to the pump.
- 27. Relief valve**  
Protects the heat exchanger from over pressure and temperature conditions. The relief valve is set at 150 PSI.
- 28. Stainless steel heat exchanger**  
Allows water to flow through specially designed coils for maximum heat transfer, while providing protection against flue gas corrosion. The coils are encased in a jacket that contains the combustion process.
- 29. Tank sensor**  
Used by the control to monitor the temperature of the tank.
- 30. Pump access panel**  
Panel used to gain access to the pump and condensate trap; also used to gain access to the outlet water sensor.
- 31. Vent pipe connection**  
Allows for the connection of the vent pipe system to the water heater.
- 32. Venturi**  
The venturi controls air and gas flow into the burner.
- 33. Water heater drain valve**  
Location from which the water heater can be drained.
- 34. Water inlet**  
Copper sweat 1-1/2" connection for cold water supply that returns water from the system to the heat exchanger.
- 35. Water outlet**  
Copper sweat 1-1/2" connection that supplies hot water to the system.
- 36. Over-temp switch (285 --500 Models Only)**  
An electrical switch designed to shut down water heater operation in the event the outer back of the heat exchanger, directly above the flue connection exceeds 604°F (318°C). This is a one time switch and could warrant a heat exchanger replacement. Check the integrity of the rear refractory at the back of the upper coil if the switch opens.

# The Shield - How it works... (continued)

## Models SWR125 - 200

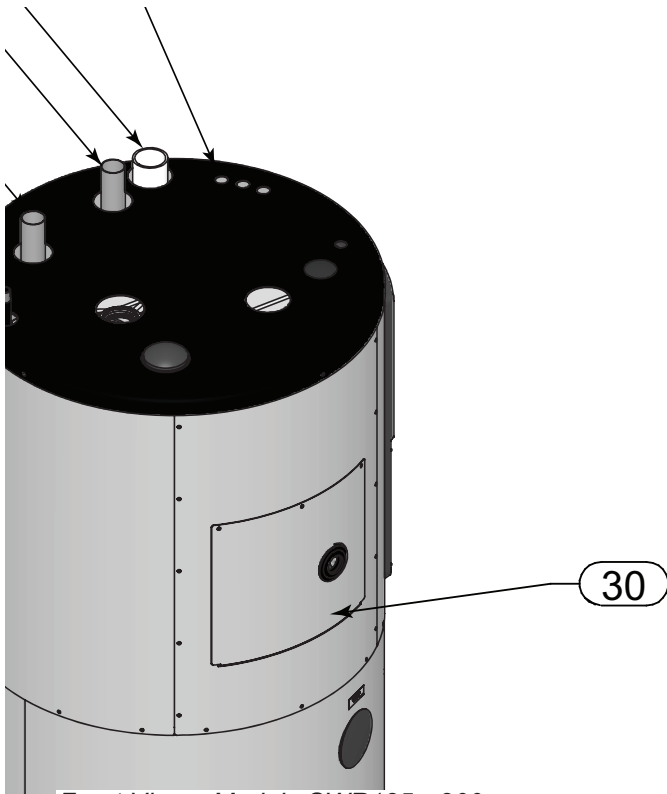

Front View - Models SWR125 - 200

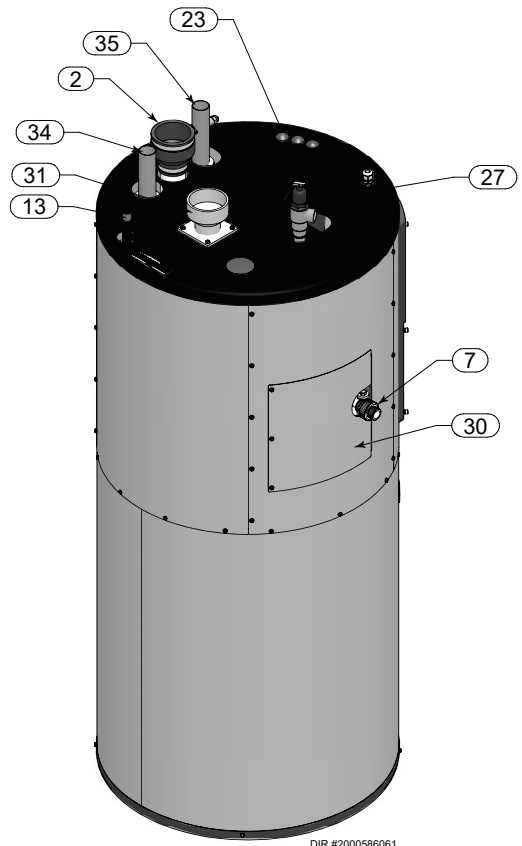

DIR #2000586061

Rear View - Models SWR125 - 200

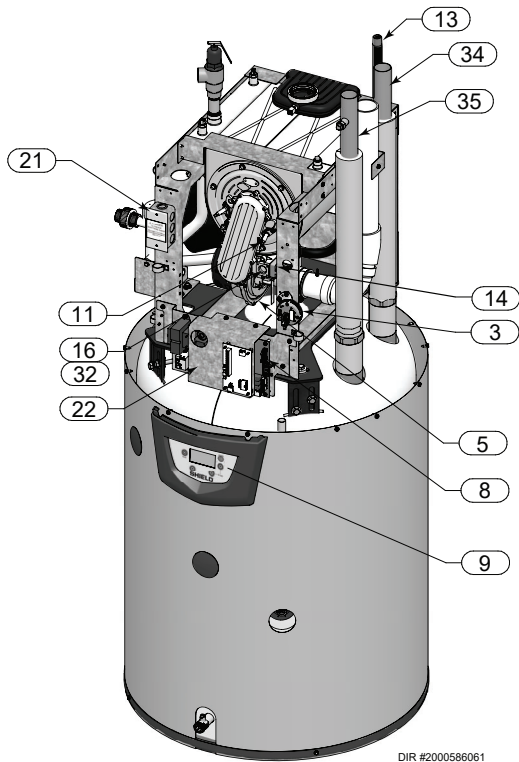

DIR #2000586061

Left Side (inside unit) -- Models SWR125 - 200

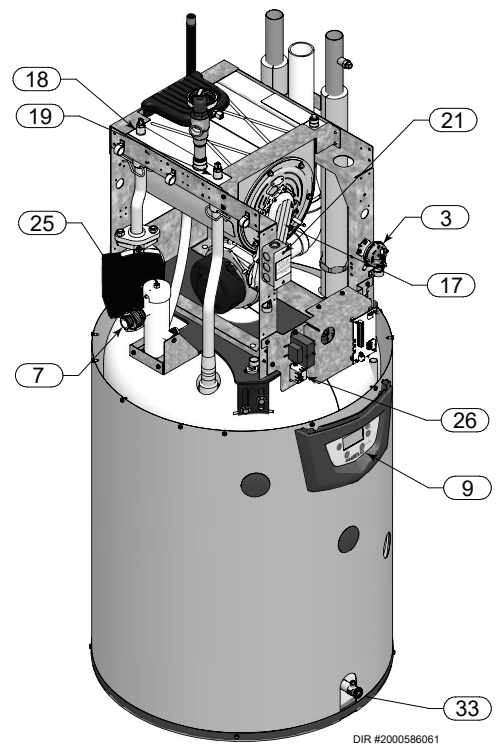

DIR #2000586061

Right Side (inside unit) -- Models SWR125 - 200

# The Shield - How it works...

## Models SWA285

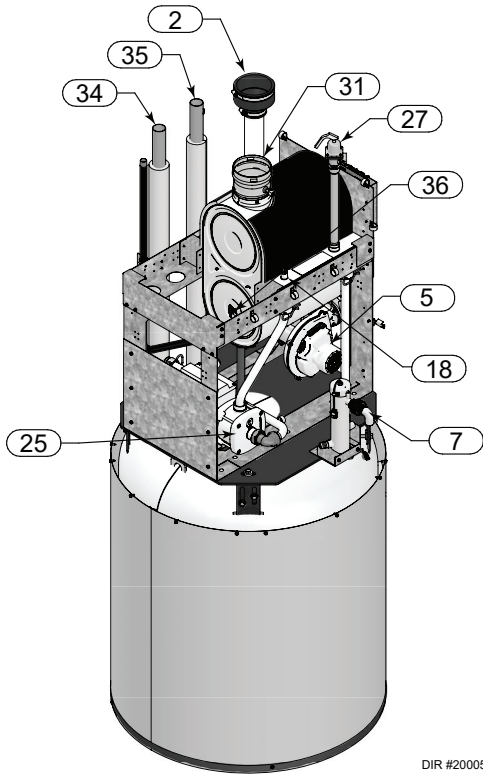

DIR #2000586074

Rear View - Models SWA285

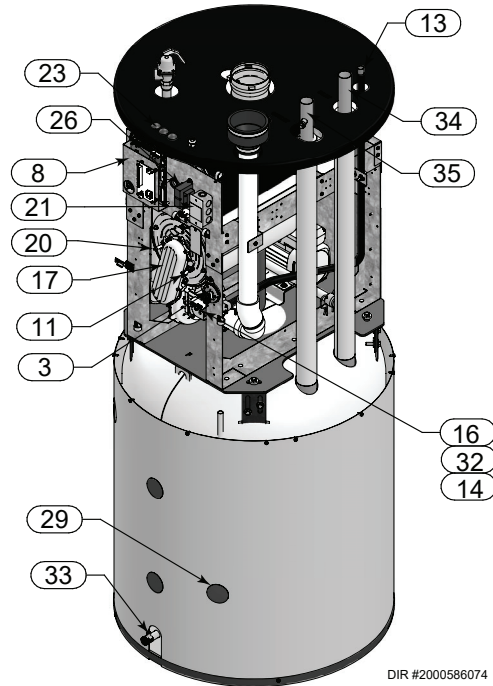

DIR #2000586074

Right Side (inside unit) - Models SWA285

## Model SWA400 - 500

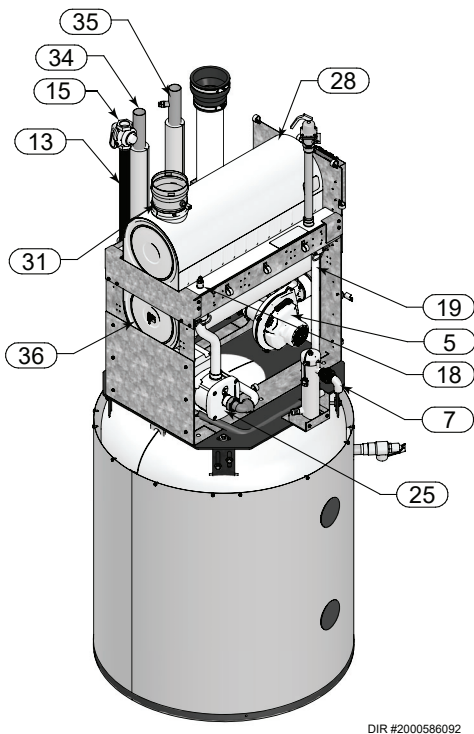

DIR #2000586092

Rear View - Model SWA400 - 500

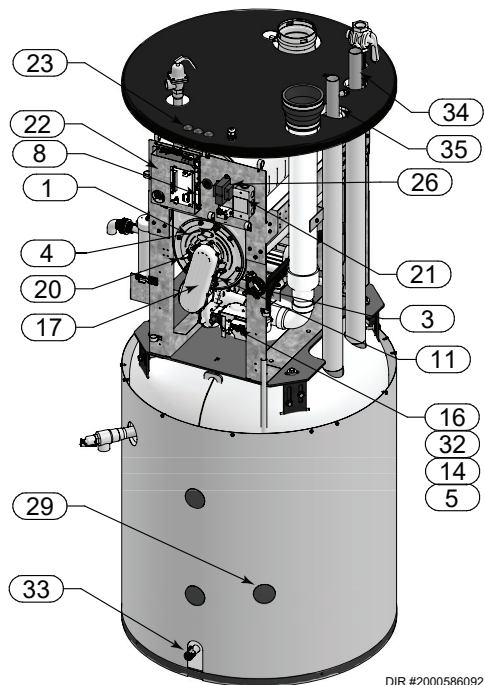

DIR #2000586092

Right Side (inside unit) - Model SWA400 - 500

## Ratings



Model Number  Note: Change "N" to "L" for L.P. gas models.	CSA Input Modulation Btu/hr (Note 2)		Water Content Gallons	Water Connections	Gas Connections	Vent/Air Size
	Min	Max				
SWR125(N,L)	25,000 - 125,000		65	1-1/2"	1/2"	3"
SWR150(N,L)	30,000 - 150,000		90	1-1/2"	1/2"	3"
SWA150(N,L)	30,000 - 150,000		91	1-1/2"	1/2"	3"
SWR200(N,L)	39,800 - 199,000		91	1-1/2"	1/2"	3"
SWA200(N,L)	39,800 - 199,000		91	1-1/2"	1/2"	3"
SWR285(N,L)	57,000 - 285,000		110	1-1/2"	1/2"	4"
SWA285(N,L)	57,000 - 285,000		110	1-1/2"	1/2"	4"
SWR400(N,L)	79,800 - 399,000		110	1-1/2"	1"	4"
SWA400(N,L)	79,800 - 399,000		110	1-1/2"	1"	4"
SWA500(N,L)	100,000 - 500,000		110	1-1/2"	1"	4"

**NOTICE**

Maximum allowed working pressure is located on the rating plate.

**Notes:**

- Shield water heaters require special gas venting. Use only the vent materials and methods specified in the Shield Installation and Service Manual.
- For US installations above 2,000 feet elevation, reference NFPA 54 for derate information.

Derate values are based on proper combustion calibration and CO<sub>2</sub>'s adjusted to the recommended levels.

- In Canada, installations above 2,000 feet elevation are not approved.

# 1 Determine water heater location

## Installation must comply with:

- Local, state, provincial, and national codes, laws, regulations, and ordinances.
- National Fuel Gas Code, ANSI Z223.1 – latest edition.
- National Electrical Code.
- For Canada only: B149.1 Installation Code, CSA C22.1 Canadian Electrical Code Part 1 and any local codes.

### NOTICE

The Shield water heater gas manifold and controls met safe lighting and other performance under tests specified in ANSI Z21.10.3 – latest edition.

## Before locating the water heater, check:

1. Check for nearby connection to:
  - Water piping
  - Venting connections
  - Gas supply piping
  - Electrical power
2. Locate the appliance so that if water connections should leak, water damage will not occur. When such locations cannot be avoided, it is recommended that a suitable drain pan, adequately drained, be installed under the appliance. Under no circumstances is the manufacturer to be held responsible for water damage in connection with this appliance, or any of its components.
3. Check area around the water heater. Remove any combustible materials, gasoline and other flammable liquids.

### WARNING

Failure to keep water heater area clear and free of combustible materials, gasoline, and other flammable liquids and vapors can result in severe personal injury, death, or substantial property damage.

4. The Shield water heater must be installed so that gas control system components are protected from dripping or spraying water or rain during operation or service.

### WARNING

This appliance is certified as an indoor appliance. Do not install the appliance outdoors or locate where the appliance will be exposed to freezing temperatures or to temperatures that exceed 100°F.

Do not install the appliance where the relative humidity may exceed 93%. Do not install the appliance where condensation may form on the inside or outside of the appliance, or where condensation may fall onto the appliance.

Failure to install the appliance indoors could result in severe personal injury, death, or substantial property damage.

### WARNING

This appliance requires a special venting system. The vent connection to the appliance must be made with the CPVC pipe section provided with the appliance. The field provided vent fittings must be cemented to the CPVC pipe section. Use only the vent materials, primer and cement specified in this manual to make the vent connections. Failure to follow this warning could result in fire, personal injury, or death.

## Closet and alcove installations

A closet is any room the water heater is installed in which is less than 433 cubic feet for 125 through 200 models and 638 cubic feet for the 285 through 500 models.

An alcove is any room which meets the criteria for a closet with the exception that it does not have a door.

**Example:** Room dimensions = 6 feet long, 6 feet wide, and 9 foot ceiling = 6 x 6 x 9 = 324 cubic feet. This would be considered a closet for a Shield Water Heater.

### WARNING

For closet and alcove installations as shown in FIG.'s 1-1 and 1-2, CPVC or stainless steel vent material must be used inside the structure. The ventilating air openings shown in FIG.'s 1-1 and 1-2 are required for this arrangement. Failure to follow this warning could result in fire, personal injury, or death.

## Provide clearances:

### Clearances from combustible materials

1. Hot water pipes—at least 1/4" from combustible materials.
2. Vent pipe – at least 1" from combustible materials.
3. See FIG.'s 1-1 and 1-2 on page 9 for other clearance minimums.

### Clearances for service access

1. See FIG.'s 1-1 and 1-2 on page 9 for recommended service clearances. If you do not provide the minimum clearances shown, it may not be possible to service the water heater without removing it from the space.



# 1 Determine water heater location *(continued)*

**Figure 1-1 Closet Installation - Minimum Required Clearances**

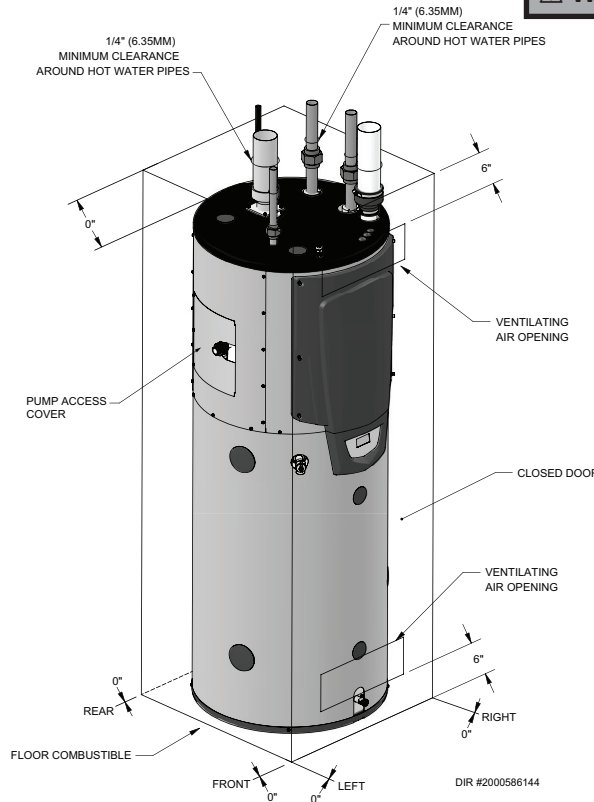

**WARNING**

For closet installations, CPVC, polypropylene or stainless steel vent material **MUST BE** used in a closet structure due to elevated temperatures. Failure to follow this warning could result in fire, personal injury, or death.

**RECOMMENDED SERVICE CLEARANCES:**

- Top - 18" (457 mm)
- Left/Right Side - 24" (610 mm)
- Front - 24" (610 mm)

**Figure 1-2 Alcove Installation - Minimum Required Clearances**

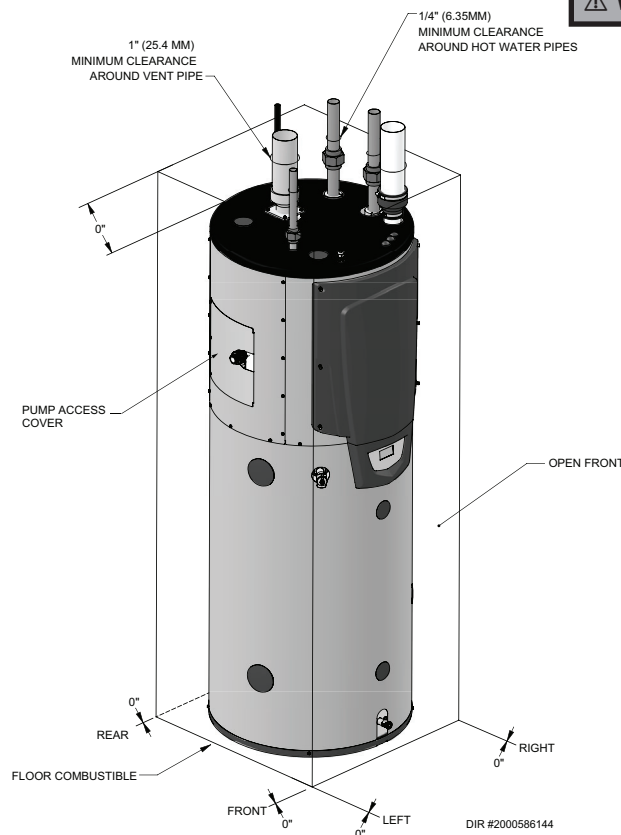

**WARNING**

For alcove installations, CPVC, polypropylene or stainless steel vent material **MUST BE** used in an alcove structure due to elevated temperatures. Failure to follow this warning could result in fire, personal injury, or death.

**RECOMMENDED SERVICE CLEARANCES:**

- Top - 18" (457 mm)
- Left/Right Side - 24" (610 mm)
- Front - 24" (610 mm)

# 1 Determine water heater location

**Table 1A Corrosive Contaminants and Sources**

Products to avoid:
Spray cans containing chloro/fluorocarbons
Permanent wave solutions
Chlorinated waxes/cleaners
Chlorine-based swimming pool chemicals
Calcium chloride used for thawing
Sodium chloride used for water softening
Refrigerant leaks
Paint or varnish removers
Hydrochloric acid/muriatic acid
Cements and glues
Antistatic fabric softeners used in clothes dryers
Chlorine-type bleaches, detergents, and cleaning solvents found in household laundry rooms
Adhesives used to fasten building products and other similar products
Areas likely to have contaminants
Dry cleaning/laundry areas and establishments
Swimming pools
Metal fabrication plants
Beauty shops
Refrigeration repair shops
Photo processing plants
Auto body shops
Plastic manufacturing plants
Furniture refinishing areas and establishments
New building construction
Remodeling areas
Garages with workshops

## Flooring and foundation

### Flooring

The Shield water heater is approved for installation on combustible flooring, but must never be installed on carpeting.

**⚠ WARNING** Do not install the water heater on carpeting even if foundation is used. Fire can result, causing severe personal injury, death, or substantial property damage.

When local codes require compliance with NSF 5, the heater must be sealed to the floor with a food grade silicone to prevent debris and harborage of vermin under the heater.

If flooding is possible, elevate the water heater sufficiently to prevent water from reaching the water heater.

### Remove water heater from wood pallet

1. Remove the sides and the top of the crate.
2. Remove the blocks on the base of the crate to allow for easier removal.
3. The water heater can then be slid off the base of the crate for installation.

**NOTICE** Do not drop the water heater or bump the jacket on the floor or pallet. Damage to the water heater can result.

### Prevent combustion air contamination

Install air inlet piping for the Shield water heater as described in this manual. Do not terminate vent/air in locations that can allow contamination of combustion air. Refer to Table 1A, for products and areas which may cause contaminated combustion air.

**⚠ WARNING** Ensure that the combustion air will not contain any of the contaminants in Table 1A. Contaminated combustion air will damage the water heater, resulting in possible severe personal injury, death or substantial property damage. Do not pipe combustion air near a swimming pool, for example. Also, avoid areas subject to exhaust fumes from laundry facilities. These areas will always contain contaminants.

# 1 Determine water heater location *(continued)*

## When using an existing vent system to install a new water heater:

**⚠ WARNING** Failure to follow all instructions can result in flue gas spillage and carbon monoxide emissions, causing severe personal injury or death.

Check the following venting components before installing:

- **Material** - For materials listed for use with this appliance, see Section 2 - General Venting. For polypropylene or stainless steel venting, an adapter of the same manufacturer must be used at the flue collar connection.
- **Size** - To ensure proper pipe size is in place, see Table 2A. Check to see that this size is used throughout the vent system.
- **Manufacturer** - For a stainless steel or polypropylene application, you must use only the listed manufacturers and their type product listed in Tables 2D and 2F for CAT IV positive pressure venting with flue producing condensate.
- **Supports** - Non-combustible supports must be in place allowing a minimum 1/4" rise per foot. The supports should adequately prevent sagging and vertical slippage, by distributing the vent system weight. For additional information, consult the vent manufacturer's instructions for installation.
- **Terminations** - Carefully review Sections 2 through 4 to ensure requirements for the location of the vent and air terminations are met and orientation of these fit the appropriate image from the Sidewall or Vertical options listed in the General Venting Section. For stainless steel vent, only use terminations listed in Table 2G for the manufacturer of the installed vent.
- **Seal** - With prior requirements met, the system should be tested to the procedure listed in parts (c) through (f) of the Removal of an Existing Water Heater Section, this page.

With polypropylene and stainless steel vent, seal and connect all pipe and components as specified by the vent manufacturer used; with PVC/CPVC vent, see the Installing Vent or Air Piping Section on page 20.

**⚠ WARNING** If any of these conditions are not met, the existing system must be updated or replaced for that concern. Failure to follow all instructions can result in flue gas spillage and carbon monoxide emissions, causing severe personal injury or death.

## When removing a water heater from existing common vent system:

**⚠ DANGER** Do not install the Shield water heater into a common vent with any other appliance. This will cause flue gas spillage or appliance malfunction, resulting in possible severe personal injury, death, or substantial property damage.

**⚠ WARNING** Failure to follow all instructions can result in flue gas spillage and carbon monoxide emissions, causing severe personal injury or death.

At the time of removal of an existing water heater, the following steps shall be followed with each appliance remaining connected to the common venting system placed in operation, while the other appliances remaining connected to the common venting system are not in operation.

- a. Seal any unused openings in the common venting system.
- b. Visually inspect the venting system for proper size and horizontal pitch and determine there is no blockage or restriction, leakage, corrosion, or other deficiencies, which could cause an unsafe condition.
- c. Test vent system – Insofar as is practical, close all building doors and windows and all doors between the space in which the appliances remaining connected to the common venting system are located and other spaces of the building. Turn on clothes dryers and any appliance not connected to the common venting system. Turn on any exhaust fans, such as range hoods and bathroom exhausts, so they will operate at maximum speed. Do not operate a summer exhaust fan. Close fireplace dampers.
- d. Place in operation the appliance being inspected. Follow the lighting instructions. Adjust thermostat so appliance will operate continuously.
- e. Test for spillage at the draft hood relief opening after 5 minutes of main burner operation. Use the flame of a match or candle, or smoke from a cigarette, cigar, or pipe.
- f. After it has been determined that each appliance remaining connected to the common venting system properly vents when tested as outlined herein, return doors, windows, exhaust fans, fireplace dampers, and any other gas-burning appliance to their previous conditions of use.
- g. Any improper operation of the common venting system should be corrected so the installation conforms with the National Fuel Gas Code, ANSI Z223.1/NFPA 54 and/or CAN/CSA B149.1, Natural Gas and Propane Installation Code. When resizing any portion of the common venting system, the common venting system should be resized to approach the minimum size as determined using the appropriate tables in Part 11 of the National Fuel Gas Code, ANSI Z223.1/NFPA and/or CAN/CSA B149.1, Natural Gas and Propane Installation Code.

# 1 Determine water heater location

Maintain minimum specified clearances for adequate operation. All installations must allow sufficient space for servicing the vent connections, water pipe connections, piping and other auxiliary equipment, as well as the appliance.

Multiple appliances may be installed in a modular water heater installation. Multiple appliances may be installed side by side with no clearance between adjacent appliances because this appliance is approved for zero clearance from combustible surfaces; however, service access will be limited from the sides. Do not block the pump access cover. (see FIG's 1-1 and 1-2.)

Consult the *Venting* section of this manual for specific installation instructions for the appropriate type of venting system that you will be using.

## Combustion and ventilation air requirements for appliances drawing air from the equipment room

Provisions for combustion and ventilation air must be in accordance with Air for Combustion and Ventilation, of the latest edition of the National Fuel Gas Code, ANSI Z223.1, in Canada, the latest edition of CGA Standard B149 Installation Code for Gas Burning Appliances and Equipment, or applicable provisions of the local building codes.

The equipment room **MUST** be provided with properly sized openings to assure adequate combustion air and proper ventilation.

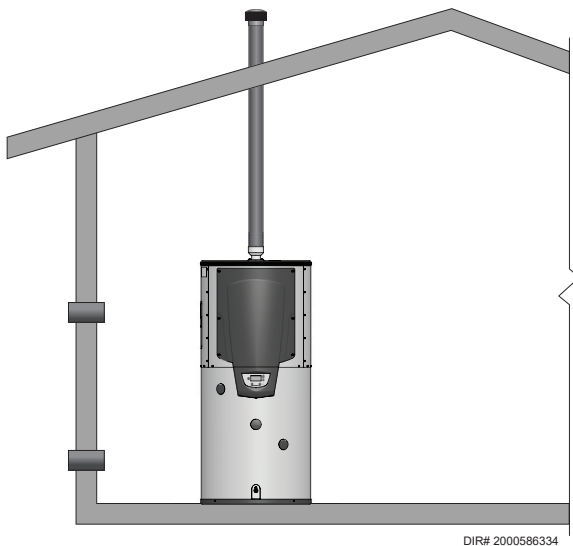

Figure 1-3\_Combustion Air Direct from Outside

1. If air is taken directly from outside the building with no duct, provide two permanent openings to the equipment room (see FIG. 1-3):

- (a) Combustion air opening, with a minimum free area of one square inch per 4000 Btu/hr input (5.5 cm<sup>2</sup> per kW). This opening must be located within 12" (30 cm) of the bottom of the enclosure.
- (b) Ventilation air opening, with a minimum free area of one square inch per 4000 Btu/hr input (5.5 cm<sup>2</sup> per kW). This opening must be located within 12" (30 cm) of the top of the enclosure.

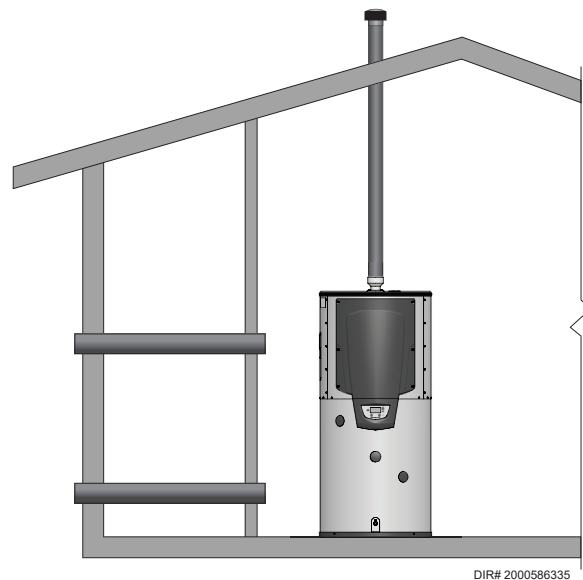
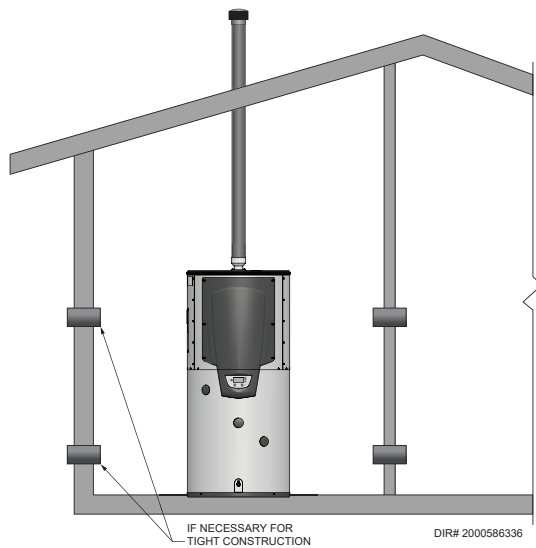

Figure 1-4\_Combustion Air Through Ducts

2. If combustion and ventilation air is taken from the outdoors using a duct to deliver the air to the equipment room, each of the two openings should be sized based on a minimum free area of one square inch per 2000 Btu/hr (11 cm<sup>2</sup> per kW) of input (see FIG. 1-4).

# 1 Determine water heater location *(continued)*



**Figure 1-5\_Combustion Air from Interior Space**

3. If air is taken from another interior space, each of the two openings specified above should have a net free area of one square inch for each 1000 Btu/hr (22 cm<sup>2</sup> per kW) of input, but not less than 100 square inches (645 cm<sup>2</sup>) (see FIG. 1-5).

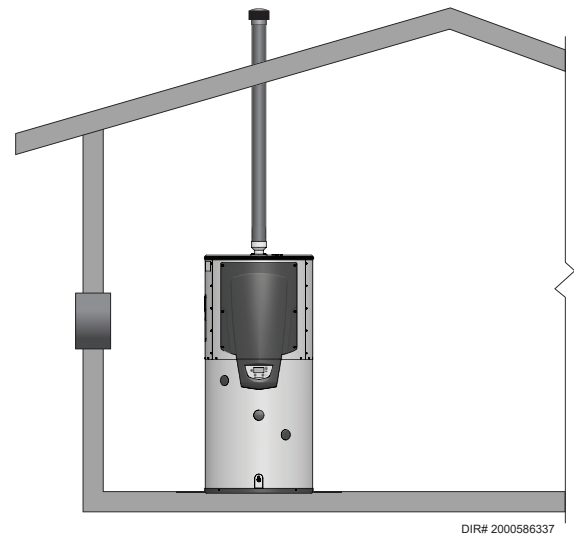

**Figure 1-6\_Combustion Air from Outside - Single Opening**

4. If a single combustion air opening is provided to bring combustion air in directly from the outdoors, the opening must be sized based on a minimum free area of one square inch per 3000 Btu/hr (7 cm<sup>2</sup> per kW). This opening must be located within 12" (30 cm) of the top of the enclosure (see FIG. 1-6).

TABLE - 1B MINIMUM RECOMMENDED COMBUSTION AIR SUPPLY TO EQUIPMENT ROOM							
Model Number	FIG. 1-3		FIG. 1-4		FIG. 1-5		FIG. 1-6
	*Outside Air from 2 Openings Directly from Outdoors		*Outside Air from 2 Ducts Delivered from Outdoors		**Inside Air from 2 Ducts Delivered from Interior Space		*Outside Air from 1 Opening Directly from Outdoors, in <sup>2</sup>
	Top Opening, in <sup>2</sup>	Bottom Opening, in <sup>2</sup>	Top Opening, in <sup>2</sup>	Bottom Opening, in <sup>2</sup>	Top Opening, in <sup>2</sup>	Bottom Opening, in <sup>2</sup>	
125	32 (207 cm <sup>2</sup> )	32 (207 cm <sup>2</sup> )	63 (407 cm <sup>2</sup> )	63 (407 cm <sup>2</sup> )	125 (807 cm <sup>2</sup> )	125 (807 cm <sup>2</sup> )	42 (271 cm <sup>2</sup> )
150	38 (246 cm <sup>2</sup> )	38 (246 cm <sup>2</sup> )	75 (484 cm <sup>2</sup> )	75 (484 cm <sup>2</sup> )	150 (968 cm <sup>2</sup> )	150 (968 cm <sup>2</sup> )	50 (323 cm <sup>2</sup> )
200	50 (323 cm <sup>2</sup> )	50 (323 cm <sup>2</sup> )	100 (646 cm <sup>2</sup> )	100 (646 cm <sup>2</sup> )	200 (1,291 cm <sup>2</sup> )	200 (1,291 cm <sup>2</sup> )	67 (433 cm <sup>2</sup> )
285	72 (465 cm <sup>2</sup> )	72 (465 cm <sup>2</sup> )	143 (923 cm <sup>2</sup> )	143 (923 cm <sup>2</sup> )	285 (1,839 cm <sup>2</sup> )	285 (1,839 cm <sup>2</sup> )	95 (613 cm <sup>2</sup> )
400	100 (646 cm <sup>2</sup> )	100 (646 cm <sup>2</sup> )	200 (1,291 cm <sup>2</sup> )	200 (1,291 cm <sup>2</sup> )	400 (2,581 cm <sup>2</sup> )	400 (2,581 cm <sup>2</sup> )	134 (865 cm <sup>2</sup> )
500	125 (807 cm <sup>2</sup> )	125 (807 cm <sup>2</sup> )	250 (1,613 cm <sup>2</sup> )	250 (1,613 cm <sup>2</sup> )	500 (3,226 cm <sup>2</sup> )	500 (3,226 cm <sup>2</sup> )	167 (1,078 cm <sup>2</sup> )

\*Outside air openings shall directly communicate with the outdoors. When combustion air is drawn from the outside through a duct, the net free area of each of the two openings must have twice (2 times) the free area required for Outside Air/2 Openings. The above requirements are for the water heater only; additional gas fired appliances in the equipment room will require an increase in the net free area to supply adequate combustion air for all appliances.

\*\*Combined interior space must be 50 cubic feet per 1,000 Btu/hr input. **Buildings MUST NOT be of "Tight Construction"**. For buildings of **"Tight Construction"**, provide air openings into the building from outside.

\*No combustion air openings are needed when the water heater is installed in a space with a volume NO LESS than 50 cubic feet per 1,000 Btu/hr of all installed gas fired appliances. **Buildings MUST NOT be of "Tight Construction"**.

\*\*"Tight Construction" is defined as a building with less than 0.40 ACH (air changes per hour).

# 1 Determine water heater location

Combustion air requirements are based on the latest edition of the National Fuel Gas Code, ANSI Z223.1; in Canada refer to the latest edition of CGA Standard CAN B149.1. Check all local code requirements for combustion air.

All dimensions based on net free area in square inches. Metal louvers or screens reduce the free area of a combustion air opening a minimum of approximately 25%. Check with louver manufacturers for exact net free area of louvers. Where two openings are provided, one must be within 12" (30cm) of the ceiling and one must be within 12" (30cm) of the floor of the equipment room. Each opening must have net free area as specified in Table 1B. Single openings shall commence within 12" (30cm) of the ceiling.

## ⚠ CAUTION

Under no circumstances should the equipment room ever be under negative pressure. Particular care should be taken where exhaust fans, attic fans, clothes dryers, compressors, air handling units, etc., may take away air from the unit.

The combustion air supply must be completely free of any flammable vapors that may ignite or chemical fumes which may be corrosive to the appliance. Common corrosive chemical fumes which must be avoided are fluorocarbons and other halogenated compounds, most commonly present as refrigerants or solvents, such as Freon, trichlorethylene, perchlorethylene, chlorine, etc. These chemicals, when burned, form acids which quickly attack the stainless steel heat exchanger, headers, flue collectors, and the vent system.

The result is improper combustion and a non-warrantable, premature appliance failure.

**EXHAUST FANS:** Any fan or equipment which exhausts air from the equipment room may deplete the combustion air supply and/or cause a downdraft in the venting system. Spillage of flue products from the venting system into an occupied living space can cause a very hazardous condition that must be immediately corrected. If a fan is used to supply combustion air to the equipment room, the installer must make sure that it does not cause drafts which could lead to nuisance operational problems with the appliance.

## 2 General venting

### Direct venting options - Sidewall Vent

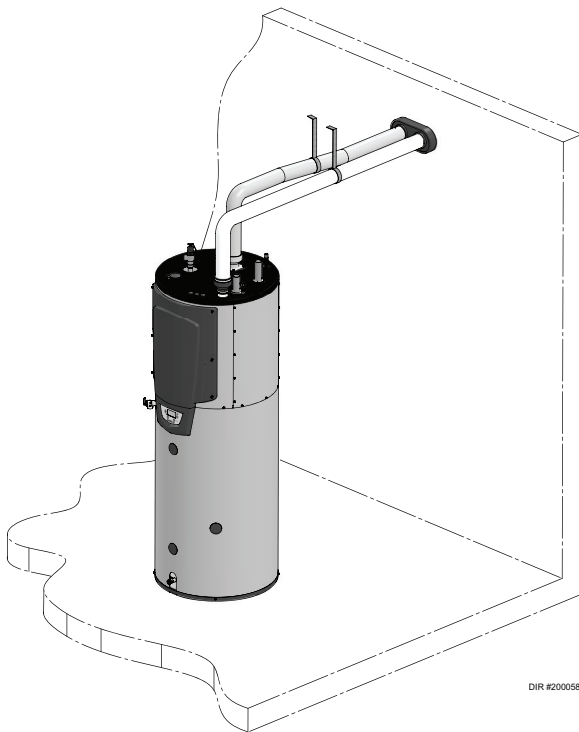

Figure 2-1 Two-Pipe Sidewall Termination

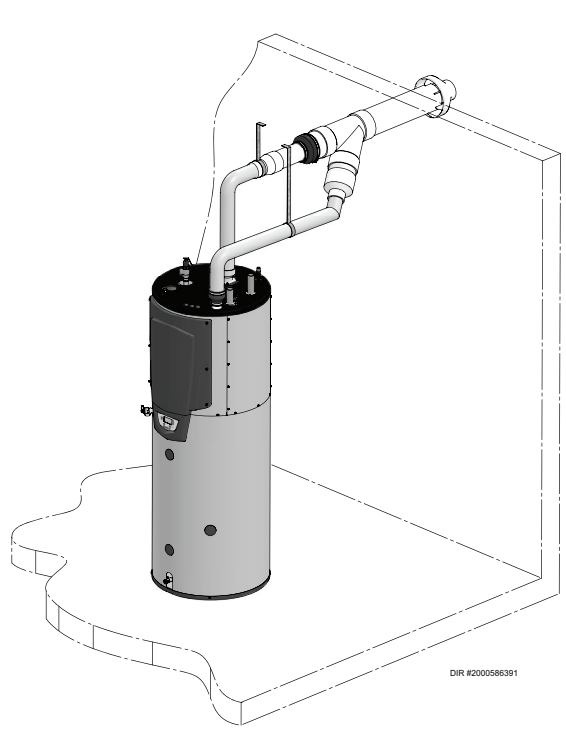

Figure 2-2 PVC/CPVC Concentric Sidewall Termination

### Direct venting options - Vertical Vent

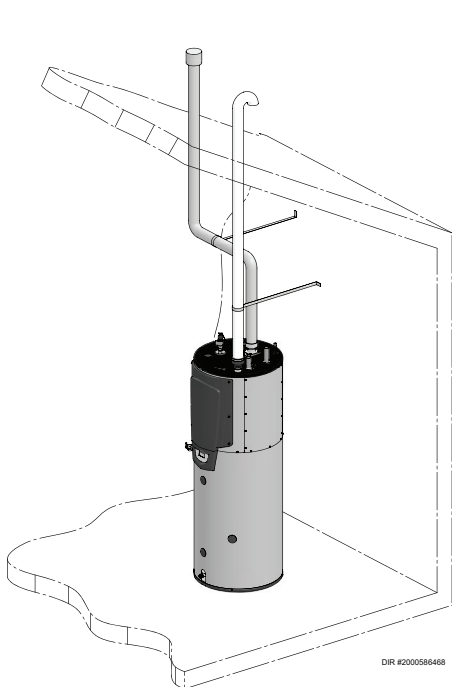

Figure 2-3 Two-Pipe Vertical Termination

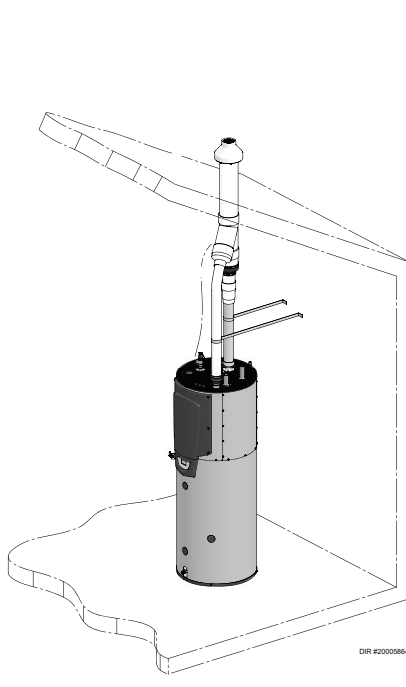

Figure 2-4 PVC/CPVC Concentric Vertical Termination

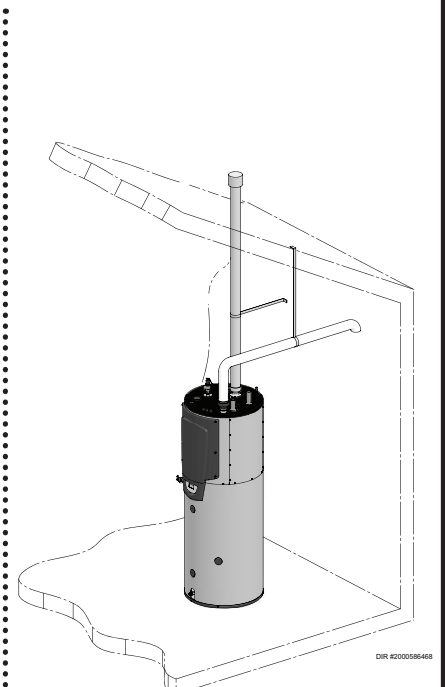

Figure 2-5 Vertical Vent, Sidewall Air

## 2 General venting

### Install vent and combustion air piping

#### ⚠ DANGER

The Shield water heater must be vented and supplied with combustion and ventilation air as described in this section. Ensure the vent and air piping and the combustion air supply comply with these instructions regarding vent system, air system, and combustion air quality. See also Section 1 of this manual.

Inspect finished vent and air piping thoroughly to ensure all are airtight and comply with the instructions provided and with all requirements of applicable codes.

Failure to provide a properly installed vent and air system will cause severe personal injury or death.

#### ⚠ WARNING

This appliance requires a special venting system. Use only approved stainless steel, PVC, CPVC or polypropylene pipe and fittings listed in Tables 2C, 2D, and 2F for vent pipe, and fittings. Failure to comply could result in severe personal injury, death, or substantial property damage.

#### ⚠ WARNING

DO NOT mix components from different systems. The vent system could fail, causing leakage of flue products into the living space. Mixing of venting materials will void the warranty and certification of the appliance.

#### NOTICE

Installation must comply with local requirements and with the National Fuel Gas Code, ANSI Z223.1 for U.S. installations or CSA B149.1 for Canadian installations.

#### ⚠ WARNING

For closet and alcove installations, CPVC, polypropylene or stainless steel material **MUST BE** used in a closet/alcove structure. Failure to follow this warning could result in fire, personal injury, or death.

#### ⚠ CAUTION

Improper installation of venting systems may result in injury or death.

#### NOTICE

Follow the instructions in Section 1, page 11 of this manual when removing a water heater from an existing vent system.

#### ⚠ WARNING

Do not connect any other appliance to the vent pipe or multiple water heaters to a common vent pipe. Failure to comply could result in severe personal injury, death, or substantial property damage.

#### NOTICE

Vent system must be pitched a 1/4" minimum per foot back to the appliance to allow drainage of condensate.

The Shield water heater vent and air piping can be installed through the roof or through a sidewall. Follow the procedures in this manual for the method chosen. Refer to the information in this manual to determine acceptable vent and air piping length.

You may use any of the vent/air piping methods covered in this manual. Do not attempt to install the Shield water heater using any other means.

You must also install air piping from outside to the water heater air intake adapter unless following the Optional Room Air instructions on page 19 of this manual. The resultant installation is direct vent (sealed combustion).

### Air intake/vent connections

1. **Combustion Air Intake Connector** (FIG. 2-6) - Used to provide combustion air directly to the unit from outdoors. A fitting is provided on the unit for final connection. Combustion air piping must be supported per guidelines listed in the National Mechanical Code, Section 305, Table 305.4 or as local codes dictate.
2. **Vent Connector** (FIG.'s 2-7 thru 2-10) - Used to provide a passageway for conveying combustion gases to the outside. A transition fitting is provided on the unit for final connection. Vent piping must be supported per the National Building Code, Section 305, Table 305.4 or as local codes dictate.

Figure 2-6 Near Water Heater Air Piping

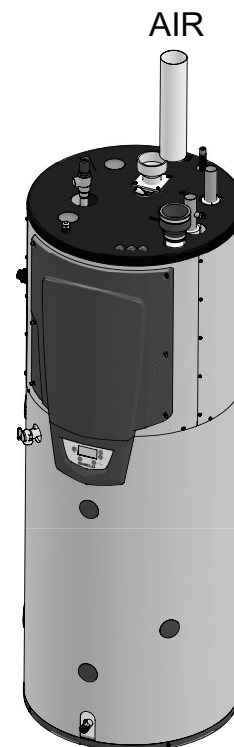

DIR #2000586184



## 2 General venting *(continued)*

### Requirements for installation in Canada

1. Installations must be made with a vent pipe system certified to ULC-S636.
2. The first three (3) feet of plastic vent pipe from the appliance flue outlet must be readily accessible for visual inspection.
3. The components of the certified vent system must not be interchanged with other vent systems or unlisted pipe/fittings. For concentric vent installations, the inner vent tube must be replaced with field supplied certified vent material to comply with this requirement.
4. The 3" Concentric Vent Kit available from Lochinvar (see Section 3 – *Sidewall Termination – Optional Concentric Vent*) and the 3" Concentric Vent Kit available from IPEX are both approved for use on the Shield water heater. Both kits are listed to the ULC-S636 standard for use in Canada.

### Sizing

The Shield water heater uses model specific combustion air intake and vent piping sizes as detailed in Table 2A-1 below.

**Table 2A Air Intake/Vent Piping Sizes**

Model	Air Intake	Vent
125 -- 200	3 inches	3 inches
285 -- 500	4 inches	4 inches

#### NOTICE

Increasing or decreasing combustion air or vent piping sizes is not authorized.

### Minimum / Maximum allowable combustion air and vent piping lengths are as follows:

**Combustion Air** = 12 equivalent feet minimum / 150 equivalent feet maximum

**Vent** = 12 equivalent feet minimum / 150 equivalent feet maximum

When determining equivalent combustion air and vent length, add 5 feet for each 90° elbow and 3 feet for each 45° elbow.

**EXAMPLE:** 20 feet of PVC pipe + (4) 90° elbows + (2) 45° elbows + (1) concentric vent kit (100140480) = 49 equivalent feet of piping.

#### NOTICE

The appliance output rating will reduce by up to 1.0% for each 25 feet of vent length.

**Table 2B Concentric Vent Kit Equivalent Vent Lengths**

Model	Kit Number	Equivalent Vent Length
125 -- 200	100140480	3 feet
285	100140484	3 feet
400	100140484	5 feet
500	100140484	30 feet

## 2 General venting

### Materials

#### Air inlet pipe materials:

The air inlet pipe(s) must be sealed. Choose acceptable combustion air inlet pipe materials from the following list:

PVC, CPVC, Polypropylene or ABS

Dryer Vent or Sealed Flexible Duct (not recommended for rooftop air inlet)

Galvanized steel vent pipe with joints and seams sealed as specified in this section.

Type "B" double-wall vent with joints and seams sealed as specified in this section.

AL29-4C, stainless steel material to be sealed to specification of its manufacturer.

\*Plastic pipe may require an adapter (not provided) to transition between the air inlet connection on the appliance and the plastic air inlet pipe.

**⚠ WARNING** Using air intake materials other than those specified can result in personal injury, death or property damage.

**NOTICE** The use of double-wall vent or insulated material for the combustion air inlet pipe is recommended in cold climates to prevent the condensation of airborne moisture in the incoming combustion air.

Sealing of Type "B" double-wall vent material or galvanized vent pipe material used for air inlet piping on a sidewall or vertical rooftop Combustion Air Supply System:

- Seal all joints and seams of the air inlet pipe using either Aluminum Foil Duct Tape meeting UL Standard 723 or 181A-P or a high quality UL Listed silicone sealant such as those manufactured by Dow Corning or General Electric.
- Do not install seams of vent pipe on the bottom of horizontal runs.
- Secure all joints with a minimum of three (3) sheet metal screws or pop rivets. Apply Aluminum Foil Duct Tape or silicone sealant to all screws or rivets installed in the vent pipe.
- Ensure that the air inlet pipes are properly supported.

The PVC, CPVC, or ABS air inlet pipe should be cleaned and sealed with the pipe manufacturer's recommended solvents and standard commercial pipe cement for the material used. The PVC, CPVC, ABS, Dryer Vent or Flex Duct air inlet pipe should use a silicone sealant to ensure a proper seal at the appliance connection and the air inlet cap connection. Dryer vent or flex duct should use a screw type clamp to seal the vent to the appliance air inlet and the air inlet cap. Proper sealing of the air inlet pipe ensures that combustion air will be free of contaminants and supplied in proper volume.

Follow the polypropylene manufacturer's instructions when using polypropylene material as an inlet pipe.

When a sidewall or vertical rooftop combustion air supply system is disconnected for any reason, the air inlet pipe must be resealed to ensure that combustion air will be free of contaminants and supplied in proper volume.

**⚠ DANGER** Failure to properly seal all joints and seams as required in the air inlet piping may result in flue gas recirculation, spillage of flue products and carbon monoxide emissions causing severe personal injury or death.

### Supports

Vent system must be supported horizontally to prevent sagging. Methods and intervals for support vary by vent manufacturer and vent material. Vent support methods and intervals shall adhere to vent manufacturer's instructions, where applicable. Vent piping must be supported per the National Building Code, Section 305, Table 305.4 or as local codes dictate.

## 2 General venting *(continued)*

### Optional room air

**NOTICE**

Optional room air is intended for commercial applications. Combustion air piping to the outside is recommended for residential applications.

Commercial applications utilizing the Shield water heater may be installed with a single pipe carrying the flue products to the outside while using combustion air from the equipment room. In order to use the room air venting option the following conditions and considerations must be followed.

- The unit **MUST** be installed with the appropriate room air provisions.
- The equipment room **MUST** be provided with properly sized openings to assure adequate combustion air. Please refer to instructions provided with the room air kit (100157615 - Models 125 -- 200 and 100157616 - Models 285 -- 500).
- There will be a noticeable increase in the noise level during normal operation from the inlet air opening.
- Using the room air configuration makes the unit vulnerable to combustion air contamination from within the building. Please review Section 1, Prevent Combustion Air Contamination, to ensure proper installation.
- Vent system and terminations must comply with the standard venting instructions set forth in this manual.

**⚠ WARNING**

When utilizing the single pipe method, provisions for combustion and ventilation air must be in accordance with Air for Combustion and Ventilation, of the latest edition of the National Fuel Gas Code, ANSI Z223.1, in Canada, the latest edition of CGA Standard B149 Installation Code for Gas Burning Appliances and Equipment, or applicable provisions of the local building codes.

### Air contamination

Pool and laundry products and common household and hobby products often contain fluorine or chlorine compounds. When these chemicals pass through the water heater, they can form strong acids. The acid can eat through the water heater wall, causing serious damage and presenting a possible threat of flue gas spillage or water heater water leakage into the building.

Please read the information given in Table 1A, page 10, listing contaminants and areas likely to contain them. If contaminating chemicals will be present near the location of the water heater combustion air inlet, have your installer pipe the water heater combustion air and vent to another location, per this manual.

**⚠ WARNING**

If the water heater combustion air inlet is located in a laundry room or pool facility, for example, these areas will always contain hazardous contaminants.

**⚠ WARNING**

To prevent the potential of severe personal injury or death, check for areas and products listed in Table 1A, page 10 before installing the water heater or air inlet piping.

If contaminants are found, you **MUST**:

- Remove contaminants permanently.
- OR—
- Relocate air inlet and vent terminations to other areas.

## 2 General venting

### PVC/CPVC

This product has been approved for use with the PVC/CPVC vent materials listed in Table 2C.

#### Installing vent and air piping

**⚠ WARNING** The vent connection to the appliance must be made with the starter CPVC pipe section provided with the 285-500 models (starter piece is factory installed on the 125-200 models) if PVC/CPVC vent is to be used. The field provided vent fittings must be cemented to the CPVC pipe section using an “All Purpose Cement” suitable for PVC and CPVC pipe. Use only the vent materials, primer, and cement specified in Table 2C to make the vent connections. Failure to follow this warning could result in fire, personal injury, or death.

**NOTICE** Use only cleaners, primers, and solvents that are approved for the materials which are joined together.

**NOTICE** All CPVC and PVC vent pipes must be glued, properly supported, and the exhaust must be pitched a minimum of a 1/4 inch per foot back to the water heater (to allow drainage of condensate). Horizontal runs shall have supports suitable for non-metallic vent piping that do not clamp tightly onto vent, allowing for vent expansion or contraction. Supports shall be as close to joints and fittings as practical and no more than 5 feet apart.

**⚠ WARNING** Insulation shall not be used on PVC or CPVC venting materials. The use of insulation will cause increased vent wall temperatures, which could result in vent pipe failure.

**NOTICE** When available, follow all vent manufacturer’s installation instructions.

**Table 2C PVC/CPVC Vent Pipe, and Fittings**

Approved PVC/CPVC Vent Pipe and Fittings		
Item	Material	Standard
Vent pipe	PVC Schedule 40, 80	ANSI/ASTM D1785
	PVC - DWV	ANSI/ASTM D2665
	CPVC Schedule 40, 80	ANSI/ASTM F441
Vent fittings	PVC Schedule 40	ANSI/ASTM D2466
	PVC Schedule 80	ANSI/ASTM D2467
	CPVC Schedule 80	ANSI/ASTM F439
	PVC - DWV	ANSI/ASTM D2665
Pipe Cement / Primer	PVC	ANSI/ASTM D2564
	CPVC	ANSI/ASTM F493

**NOTICE: DO NOT USE CELLULAR (FOAM) CORE PIPE**

NOTE: In Canada, CPVC and PVC vent pipe, fittings and cement/primer must be ULC-S636 certified.

1. Work from the water heater to vent or air termination. Do not exceed the lengths given in this manual for the air or vent piping.
2. Cut pipe to the required lengths and deburr the inside and outside of the pipe ends.
3. Chamfer outside of each pipe end to ensure even cement distribution when joining.
4. Clean all pipe ends and fittings using a clean dry rag. (Moisture will retard curing and dirt or grease will prevent adhesion.)
5. Dry fit vent or air piping to ensure proper fit up before assembling any joint. The pipe should go a third to two-thirds into the fitting to ensure proper sealing after cement is applied.
6. Priming and Cementing:
  - a. Handle fittings and pipes carefully to prevent contamination of surfaces.
  - b. Apply a liberal even coat of primer to the fitting socket and to the pipe end to approximately 1/2" beyond the socket depth.
  - c. Apply a second primer coat to the fitting socket.
  - d. While primer is still wet, apply an even coat of approved cement to the pipe equal to the depth of the fitting socket along with an even coat of approved cement to the fitting socket.
  - e. Apply a second coat of cement to the pipe.
  - f. While the cement is still wet, insert the pipe into the fitting, if possible twist the pipe a 1/4 turn as you insert it. **NOTE:** If voids are present, sufficient cement was not applied and joint could be defective.
  - g. Wipe excess cement from the joint removing ring or beads as it will needlessly soften the pipe.

**Figure 2-7 Near Water Heater PVC/CPVC Venting**

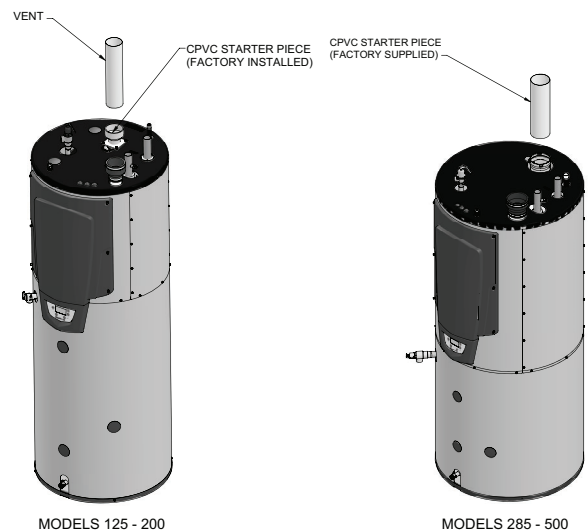

# 2 General venting *(continued)*

## Polypropylene

This product has been approved for use with polypropylene vent with the manufacturers listed in Table 2D.

All terminations must comply with listed options in this manual and be a single-wall vent offering.

For support and special connections required, see the manufacturer's instructions. All vent is to conform to standard diameter and equivalent length requirements established.

When determining equivalent combustion air and vent length for polypropylene single-wall piping:

- 1 foot of Duravent 4 inch single-wall pipe is equivalent to 1.6 feet of piping

## Flexible polypropylene

For use of flex pipe, it is recommended to have the vent material in 32°F or higher ambient space before bending at installation. No bends should be made to greater than 45° and ONLY installed in vertical or near vertical installations (FIG. 2-8).

**Figure 2-8 Near Boiler Flexible Polypropylene Venting**

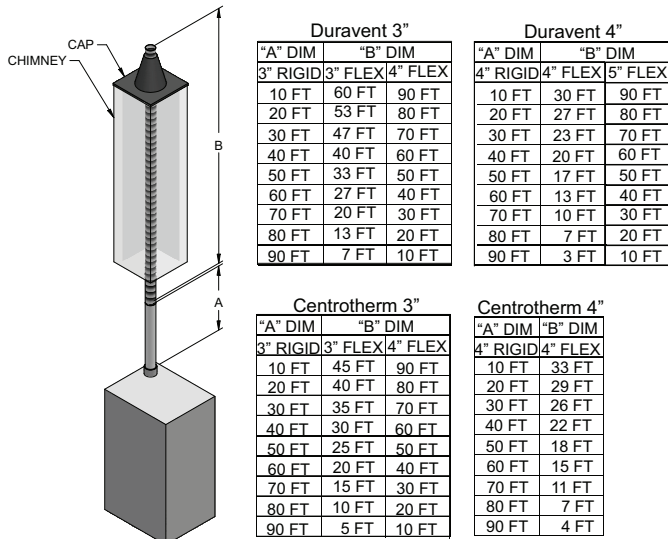

\*NOTES: 1) FLEX PIPE MAY ONLY BE RUN IN A VERTICAL ORIENTATION  
 2) ALL VENT LENGTHS REPRESENTED IN ABOVE CHARTS ARE EQUIVALENT LENGTHS.  
 3) SECTION A IS EQUIVALENT FEET OF RIGID PIPE, WHICH MAY INCLUDE 45 AND 90° ELBOWS. PLEASE SEE SIZING SECTION FOR DETERMINING EQUIVALENT FEET.  
 IMG00840

**NOTICE**

The installer must use a specific vent starter adapter at the flue collar connection. The adapter is supplied by the vent manufacturer to adapt to its vent system. See Table 2E for approved vent adapters. Discard CPVC starter piece.

**NOTICE**

All vent connections MUST be secured by the vent manufacturer's joint connector (FIG. 2-9).

**WARNING**

Insulation should not be used on polypropylene venting materials. The use of insulation will cause increased vent wall temperatures, which could result in vent pipe failure.

**WARNING**

Use only the adapters and vent system listed in Tables 2D and 2E. DO NOT mix vent systems of different types or manufacturers. Failure to comply could result in severe personal injury, death, or substantial property damage.

**NOTICE**

Installations must comply with applicable national, state, and local codes. For Canadian installation, polypropylene vent must be listed as a ULC-S636 approved system.

**NOTICE**

Installation of a polypropylene vent system should adhere to the vent manufacturer's installation instructions supplied with the vent system.

**Figure 2-9 Near Water Heater Polypropylene Venting**

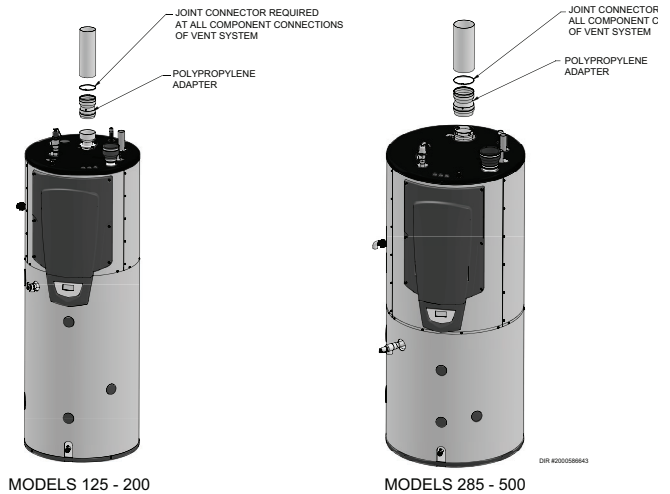

**Table 2D Polypropylene Vent Pipe and Fittings**

Approved Polypropylene Vent Manufacturers		
Make	Model	Standard
Centrotherm Eco Systems	InnoFlue SW/Flex	UL-1738/ULC-S636
Duravent (M & G Group)	PolyPro Single-Wall / PolyPro Flex	ULC-S636

**Table 2E Approved Polypropylene Terminations**

Model	Centrotherm InnoFlue SW					Duravent Polypro		
	Polypropylene Adapter	Joint Connector	Sidewall Kit*	Sidewall Retaining Bracket*	Sidewall Adapter*	Polypropylene Adapter	Joint Connector	Sidewall Kit*
125 -- 200	ISAGL0303	IANS03	ISLPT0303	IATP0303	ISTAGL0303	3PPS-ADL	3PPS-LB	3PPS-HLK
285 -- 500	ISAAL0404	IANS04	ISLPT0404	IATP0404	ISTAGL0404	4PPS-AD-M	4PPS-LB	4PPS-HLK

\* These parts are only needed if the sidewall termination assembly is used (see FIG. 3-4B on page 28).

## 2 General venting

### Stainless steel vent

This product has been approved for use with stainless steel using the manufacturers listed in Table 2F. This unit requires Category IV venting.

**WARNING** Use only the materials, vent systems, and terminations listed in Tables 2F and 2G. DO NOT mix vent systems of different types or manufacturers. Failure to comply could result in severe personal injury, death, or substantial property damage.

**NOTICE** The installer must use a specific vent starter adapter at the flue collar connection, supplied by the vent manufacturer to adapt to its vent system. See Table 2G for approved vent adapters. Discard CPVC starter piece.

**NOTICE** Installations must comply with applicable national, state, and local codes. Stainless steel vent systems must be listed as a UL-1738 approved system for the United States and a ULC-S636 approved system for Canada.

**NOTICE** Installation of a stainless steel vent system should adhere to the stainless steel vent manufacturer's installation instructions supplied with the vent system.

Figure 2-10 Near Water Heater Stainless Steel Venting

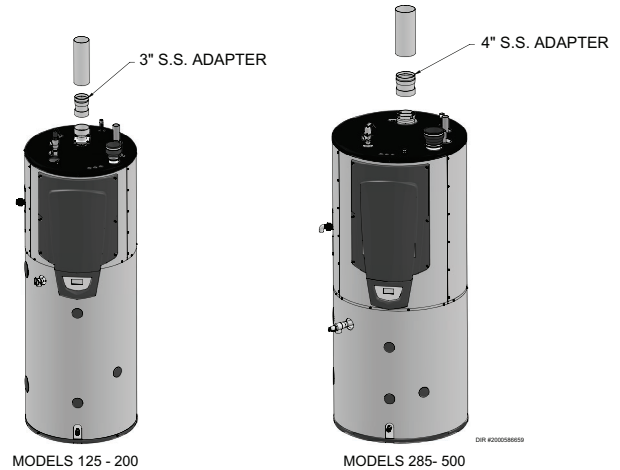

\*Use of FasNSeal Flex smooth inner wall vent is to be used in vertical or near vertical sections only, taking precaution to ensure no sagging occurs of the vent system. Connect to the FasNSeal rigid vent using specially designed adapters and sealing method, see manufacturer's instructions.

Table 2F Stainless Steel Vent Pipe and Fittings

Approved Stainless Steel Vent Manufacturers		
Make	Model	Standard
Duravent (M & G Group)	FasNSeal	UL 1738/ULC-S636
Dura Vent (M & G Group)	FasNSeal Flex* Vent	UL 1738/UL 1777/ULC-S636
Z-Flex (Nova Flex Group)	Z-Vent	UL 1738/ULC-S636
Heat Fab (Selkirk Corporation)	Saf-T Vent	UL 1738/ULC-S636/UL 641/ULC-S609
Metal Fab	Corr/Guard	UL 1738/ULC-S636
Security Chimney	Secure Seal	UL 1738/ULC-S636

Table 2G Approved Stainless Steel (S.S.) Terminations and Adapters

Model	ProTech			Heat Fab			Z Flex		
	FasNSeal			Saf-T Vent			Z-Vent		
	S.S. Adapter	Flue Termination	Intake Air Termination	S.S. Adapter	Flue Termination	Intake Air Termination	S.S. Adapter	Flue Termination	Intake Air Termination
125 -- 200	300715	FSBS3 FSRC3(R.C)	303889	9301PVC	9392 5300CI	9314TERM	2SVSLA03	2SVSTP03 2SVSRCX03	2SVSTEX0390
285 -- 500	F303759	FSBS4 FSRC4(R.C.)	FSAIH04 303888	9401PVC	9492 5400CI	9414TERM	2SVSLA04	2SVSTP04 2SVSRCX04	2SVSTEX0490
<b>Metal Fab</b>			<b>Security Chimney</b>						
Corr/Guard			Secure Seal						
125 -- 200	3CGPVCA	3CGSWHT 3CGSWC	3CGSW90LT	--	--	--			
285 -- 500	4CGPVCA	4CGSWHT 4CGSWC	4CGSW90LT	SS4PVCU	SS4STU SS4RCBU	SS4ST90AU			

### 3 Sidewall direct venting

#### Vent/air termination – sidewall

**⚠ WARNING** Follow instructions below when determining vent location to avoid possibility of severe personal injury, death, or substantial property damage.

**⚠ WARNING** A gas vent extending through an exterior wall shall not terminate adjacent to a wall or below building extensions such as eaves, parapets, balconies, or decks. Failure to comply could result in severe personal injury, death, or substantial property damage.

#### Determine location

Locate the vent/air terminations using the following guidelines:

- The total length of piping for vent or air must not exceed the limits given in the General Venting Section on page 17 of this manual.
- You must consider the surroundings when terminating the vent and air:
  - Position the vent termination where vapors will not damage nearby shrubs, plants or air conditioning equipment or be objectionable.
  - The flue products will form a noticeable plume as they condense in cold air. Avoid areas where the plume could obstruct window views.
  - Prevailing winds could cause freezing of condensate and water/ice buildup where flue products impinge on building surfaces or plants.
  - Avoid possibility of accidental contact of flue products with people or pets.
  - Do not locate the terminations where wind eddies could affect performance or cause recirculation, such as inside building corners, near adjacent buildings or surfaces, window wells, stairwells, alcoves, courtyards, or other recessed areas.

**⚠ WARNING** Sidewall vent and air inlet terminations must terminate in the same pressure zone.

- Do not terminate above any door or window. Condensate can freeze, causing ice formations.
- Locate or guard vent to prevent condensate damage to exterior finishes.
- Do not locate the terminations over public walkways.
- Do not locate the terminations near soffit vents, crawl space vents, or other areas where condensate or vapor could create a nuisance, hazard, or cause property damage.
- Do not locate the terminations where condensate vapor could cause damage or could be detrimental to the operation of regulators, relief valves, or other equipment.
- Terminations must be located a minimum of 12" above grade or maximum snow line.

**Figure 3-1A** PVC/CPVC/Polypropylene Sidewall Termination of Air and Vent

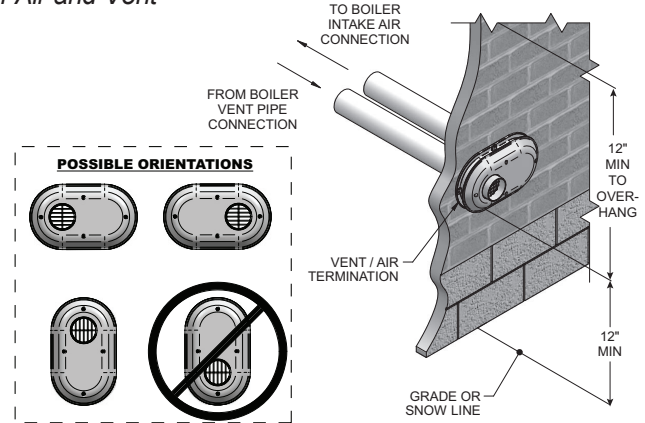

**Table 3A** Sidewall Vent Kits

Model	Kit Number	Vent Size
125 -- 200	100157610	3 inch vent
285 -- 500	100157611	4 inch vent

#### If using the alternate sidewall termination:

- The air piping must terminate in a down-turned elbow as shown in FIG. 3-1B. This arrangement avoids recirculation of flue products into the combustion air stream.
- The vent piping must terminate in an elbow pointed outward or away from the air inlet, as shown in FIG. 3-1B.

**⚠ WARNING** Do not exceed the maximum lengths of the outside vent piping shown in FIG. 3-1B. Excessive length exposed to the outside could cause freezing of condensate in the vent pipe, resulting in potential water heater shutdown.

**Figure 3-1B** Alternate PVC/CPVC/Polypropylene Sidewall Termination of Air and Vent w/Field Supplied Fittings

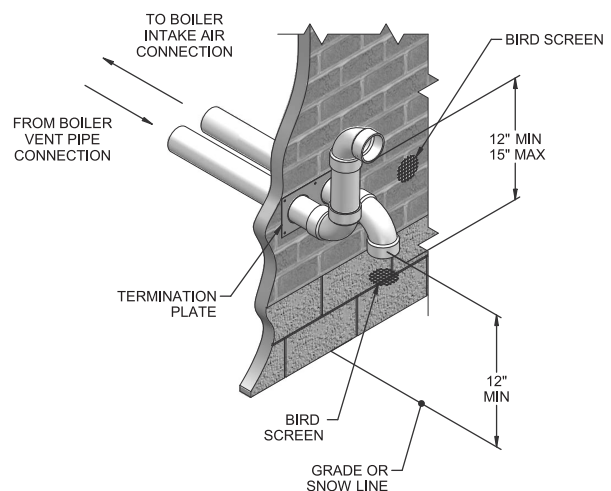

### 3 Sidewall direct venting

#### Vent/air termination – sidewall

**Figure 3-1C** Alternate PVC/CPVC/SS/ Polypropylene Venting Arrangement (if Space Allows) w/Field Supplied Fittings

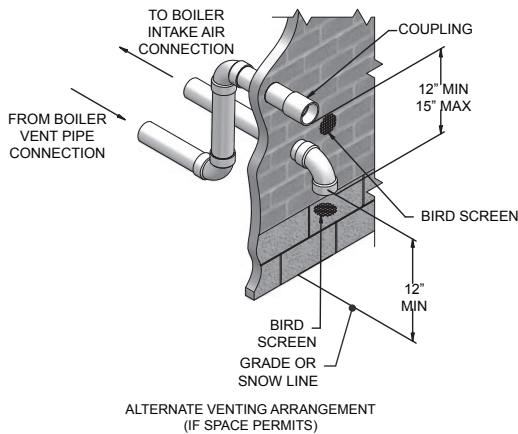

**Figure 3-1D** Alternate SS Venting Arrangement - Typical Stainless Steel Sidewall Termination of Air and Vent w/Field Supplied Fittings, Utilizing a Hood Intake

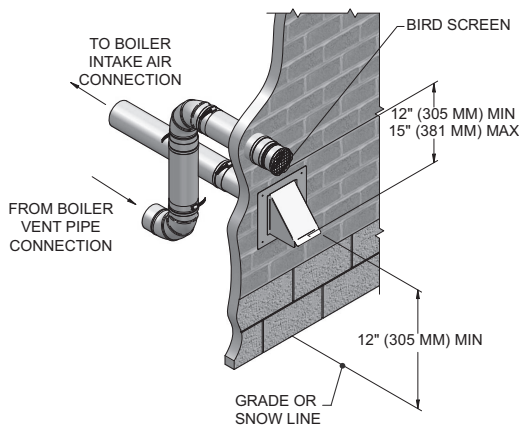

5. Maintain clearances as shown in FIG.'s 3-1A thru 3-3B, pages 23 - 26. Also maintain the following:
  - a. Vent must terminate:
    - At least 6 feet from adjacent walls.
    - No closer than 12 inches below roof overhang.
  - b. Air inlet must terminate at least 12 inches above grade or snow line; at least 12 inches below the vent termination; and the vent pipe must not extend more than 24 inches vertically outside the building as shown in FIG. 3-1B. Condensate could freeze and block vent pipe.
  - c. Do not terminate closer than 4 feet horizontally from any electric meter, gas meter, regulator, relief valve, or other equipment. Never terminate above or below any of these within 4 feet horizontally.

6. Locate terminations so they are not likely to be damaged by foreign objects, such as stones or balls, or subject to buildup of leaves or sediment.

**Figure 3-2A** Clearance to Gravity Air Inlets

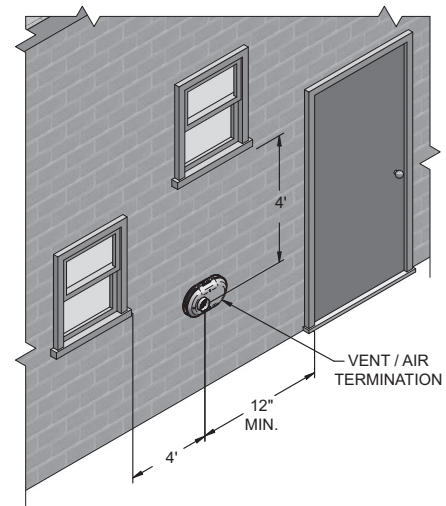

**Figure 3-2B** Alternate Clearance to Gravity Air Inlets w/ Field Supplied Fittings

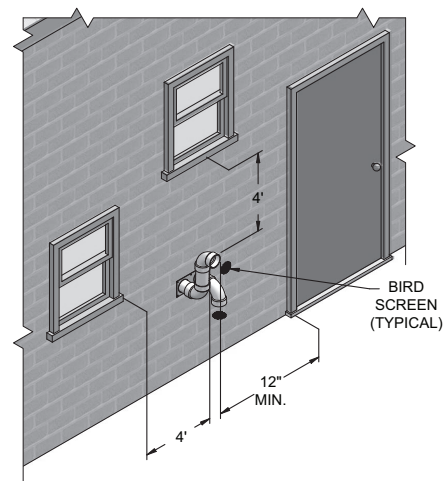



### 3 Sidewall direct venting *(continued)*

Figure 3-3A Direct Vent Terminal Clearances

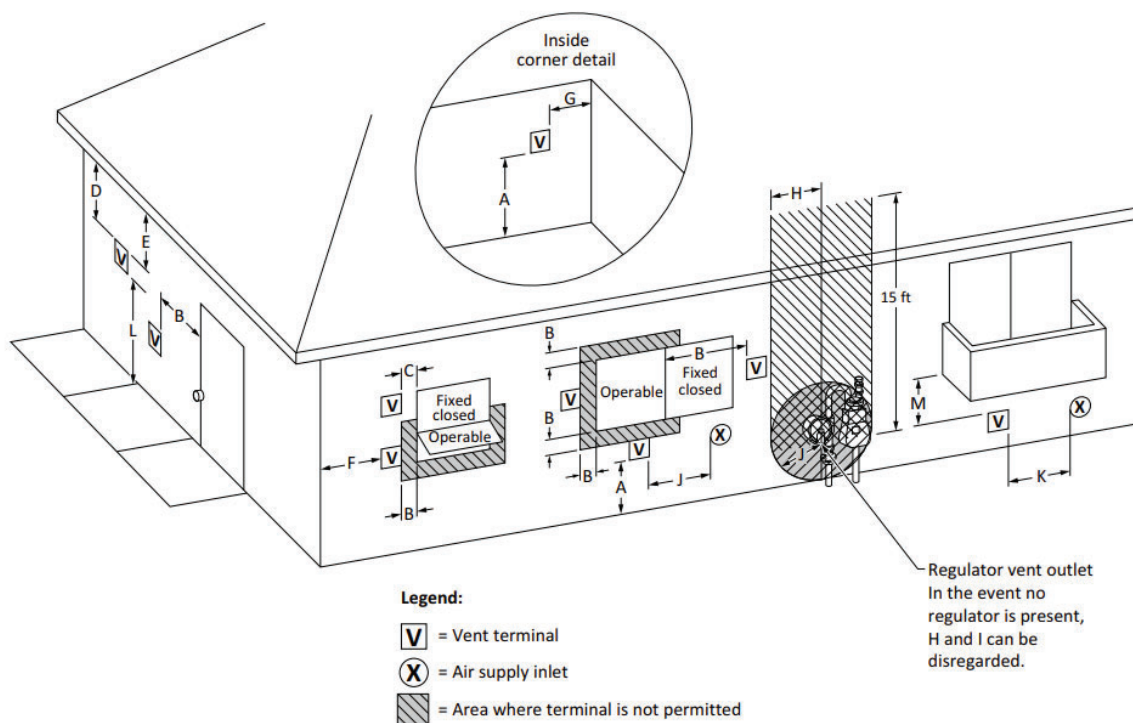

Table 3B Direct Vent Terminal Clearances

		Canadian Installations <sup>1</sup>	US Installations <sup>2</sup>
A =	Clearance above grade, veranda, porch, deck, or balcony	12 in (30 cm)	12 in (30 cm)
B =	Clearance to window or door that may be opened	6 in (15 cm) for appliances ≤ 10,000 Btuh (3 kW), 12 in (30 cm) for appliances > 10,000 Btuh (3 kW) and ≤ 100,000 Btuh (30 kW), 36 in (91 cm) for appliances > 100,000 Btuh (30 kW)	6 in (15 cm) for appliances ≤ 10,000 Btuh (3 kW), 9 in (23 cm) for appliances > 10,000 Btuh (3 kW) and ≤ 50,000 Btuh (15 kW), 12 in (30 cm) for appliances > 50,000 Btuh (15 kW)
C =	Clearance to permanently closed window	*	*
D =	Vertical clearance to ventilated soffit located above the terminal within a horizontal distance of 2 ft (61 cm) from the center line of the terminal.	*	*
E =	Clearance to unventilated soffit	*	*
F =	Clearance to outside corner	*	*
G =	Clearance to inside corner	*	*
H =	Clearance to each side of center line extended above meter / regulator assembly	3 ft (91 cm) within a height 15 ft (4.6 m)	*
I =	Clearance to service regulator vent outlet	3 ft (91 cm)	*

### 3 Sidewall direct venting

**Table 3B** Direct Vent Terminal Clearances (continued)

J =	Clearance to nonmechanical air supply inlet to building or the combustion air inlet to any other appliance	6 in (15 cm) for appliances $\leq 10,000$ Btuh (3kW), 12 in (30 cm) for appliances $> 10,000$ Btuh (3 kW) and $\leq 100,000$ Btuh (30 kW), 36 in (91 cm) for appliances $> 100,000$ Btuh (30 kW)	6 in (15 cm) for appliances $\leq 10,000$ Btuh (3kW), 9 in (23 cm) for appliances $> 10,000$ Btuh (3 kW) and $\leq 50,000$ Btuh (15 kW), 12 in (30 cm) for appliances $> 50,000$ Btuh (15 kW)
K =	Clearance to a mechanical air supply inlet	6 ft (1.83 m)	3 ft (91 cm) above if within 10 ft (3 m) horizontally
L =	Clearance above paved sidewalk or paved driveway located on public property	7 ft (2.13 m)†	7 ft (2.13 m) for mechanical draft systems (Category I appliances). Vents for Category II and IV appliances cannot be located above public walkways or other areas where condensate or vapor can cause a nuisance or hazard
M =	Clearance under veranda, porch, deck, or balcony	12 in (30 cm)‡	*

\* Clearance in accordance with local installation codes and the requirements of the gas supplier.

† A vent shall not terminate directly above a sidewalk or paved driveway that is located between two single family dwellings and serves both dwellings.

‡ Permitted only if veranda, porch, deck, or balcony is fully open on a minimum of two sides beneath the floor.

**NOTES:**

- 1) In accordance with the current CSA B149.1, Natural Gas and Propane Installation Code
- 2) In accordance with the current ANSI Z223.1/NFPA 54, National Fuel Gas Code

**Figure 3-3B** Other than Direct Vent Terminal Clearances

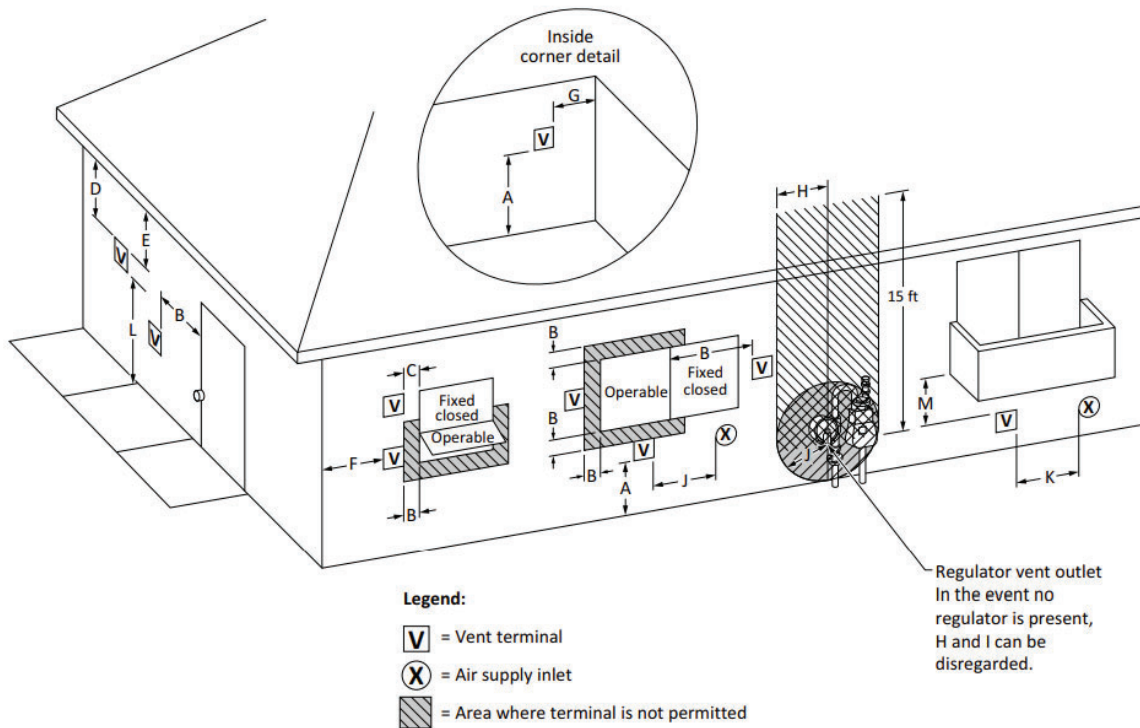

### 3 Sidewall direct venting *(continued)*

**Table 3C** Other than Direct Vent Terminal Clearances

		Canadian Installations <sup>1</sup>	US Installations <sup>2</sup>
A =	Clearance above grade, veranda, porch, deck, or balcony	12 in (30 cm)	12 in (30 cm)
B =	Clearance to window or door that may be opened	6 in (15 cm) for appliances ≤ 10,000 Btuh (3 kW), 12 in (30 cm) for appliances > 10,000 Btuh (3 kW) and ≤ 100,000 Btuh (30 kW), 36 in (91 cm) for appliances > 100,000 Btuh (30 kW)	4 ft (1.2 m) below or to side of opening; 1 ft (300 mm) above opening
C =	Clearance to permanently closed window	*	*
D =	Vertical clearance to ventilated soffit located above the terminal within a horizontal distance of 2 ft (61 cm) from the center line of the terminal.	*	*
E =	Clearance to unventilated soffit	*	*
F =	Clearance to outside corner	*	*
G =	Clearance to inside corner	*	*
H =	Clearance to each side of center line extended above meter / regulator assembly	3 ft (91 cm) within a height 15 ft (4.6 m)	*
I =	Clearance to service regulator vent outlet	3 ft (91 cm)	*
J =	Clearance to nonmechanical air supply inlet to building or the combustion air inlet to any other appliance	6 in (15 cm) for appliances ≤ 10,000 Btuh (3kW), 12 in (30 cm) for appliances > 10,000 Btuh (3 kW) and ≤ 100,000 Btuh (30 kW), 36 in (91 cm) for appliances > 100,000 Btuh (30 kW)	4 ft (1.2 m) below or to side of opening; 1 ft (300 mm) above opening
K =	Clearance to a mechanical air supply inlet	6 ft (1.83 m)	3 ft (91 cm) above if within 10 ft (3 m) horizontally
L =	Clearance above paved sidewalk or paved driveway located on public property	7 ft (2.13 m)†	7 ft (2.13 m) for mechanical draft systems (Category I appliances). Vents for Category II and IV appliances cannot be located above public walkways or other areas where condensate or vapor can cause a nuisance or hazard
M =	Clearance under veranda, porch, deck, or balcony	12 in (30 cm)‡	*
<p>* Clearance in accordance with local installation codes and the requirements of the gas supplier.  † A vent shall not terminate directly above a sidewalk or paved driveway that is located between two single family dwellings and serves both dwellings.  ‡ Permitted only if veranda, porch, deck, or balcony is fully open on a minimum of two sides beneath the floor.</p> <p><b>NOTES:</b>  1) In accordance with the current CSA B149.1, Natural Gas and Propane Installation Code  2) In accordance with the current ANSI Z223.1/NFPA 54, National Fuel Gas Code</p>			

### 3 Sidewall direct venting

#### Prepare wall penetrations

1. Reference Table 3D when locating the vent and air intake holes and mounting holes.

Air pipe penetration:

- a. Cut a hole for the air pipe. Size the air pipe hole as close as desired to the air pipe outside diameter.

Vent pipe penetration:

- a. Cut a hole for the vent pipe. For either combustible or noncombustible construction, size the vent pipe hole with at least a 1/2 inch clearance around the vent pipe outer diameter:
  - 4½ inch hole for 3 inch vent pipe
  - 5½ inch hole for 4 inch vent pipe

Drill 3/16" diameter holes for inserting the plastic anchors into the wall.

- b. Insert a galvanized metal nipple in the vent pipe hole as shown in FIG. 3-4B.
2. For Polypropylene Only: Install the vent and air intake sidewall adapters from Table 2E on page 21 into the vent plate. Slide the sidewall retaining bracket down the sidewall adapters flush to the vent plate (FIG. 3-4B).
  3. For PVC/CPVC Only: Install the vent and air intake piping through the wall into the vent plate openings. Use RTV silicone sealant to seal the air pipe. Use the cement/primer listed in Table 2C on page 20 to seal the vent pipe.
  4. Mount and secure the vent plate to the wall, using stainless steel screws.
  5. Seal all gaps between the pipes and wall. Seal around the plate to the wall assuring no air gaps.
  6. Assemble the vent cap to the vent plate (see FIG.'s 3-4A and 3-4B). Insert the stainless steel screws into the vent cap screw hole openings and securely attach the vent cap to the vent plate.
  7. Seal all wall cavities.
  8. PVC/CPVC terminations are designed to accommodate any wall thickness of standard constructions per the directions found in this manual.
  9. Stainless steel terminations are designed to penetrate walls with a thickness up to 9.25 inches of standard construction.

Figure 3-4A PVC/CPVC Sidewall Termination Assembly

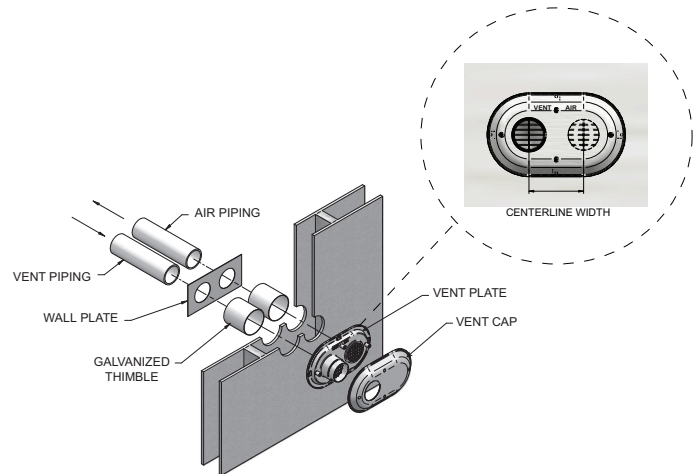
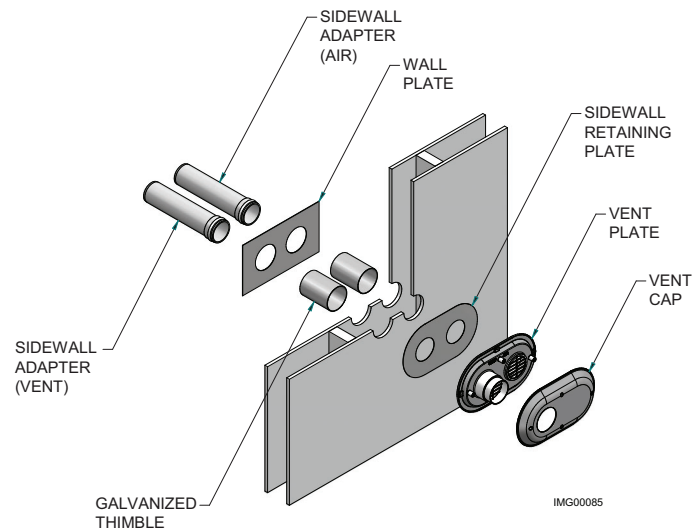

Table 3D Sidewall Vent Centerline Dimensions

Model	Air	Vent	Centerline Width
125 -- 200	3"	3"	5 5/8"
285 -- 500	4"	4"	5 5/8"

Figure 3-4B Polypropylene Sidewall Termination Assembly



### 3 Sidewall direct venting *(continued)*

#### Prepare wall penetrations (Alternate - Field Supplied Option)

- Air pipe penetration:
  - Cut a hole for the air pipe. Size the air pipe hole as close as desired to the air pipe outside diameter.
- Vent pipe penetration:
  - Cut a hole for the vent pipe. For either combustible or noncombustible construction, size the vent pipe hole with at least a 1/2 inch clearance around the vent pipe outer diameter:
    - 4½ inch hole for 3 inch vent pipe
    - 5½ inch hole for 4 inch vent pipe
  - Insert a galvanized metal thimble in the vent pipe hole as shown in FIG. 3-4C.
- Reference Table 3D for the correct location of hole centers.
- Follow all local codes for isolation of vent pipe when passing through floors or walls.
- Seal exterior openings thoroughly with exterior caulk.

**Figure 3-4C** Alternate Sidewall Termination Assembly w/Field Supplied Fittings

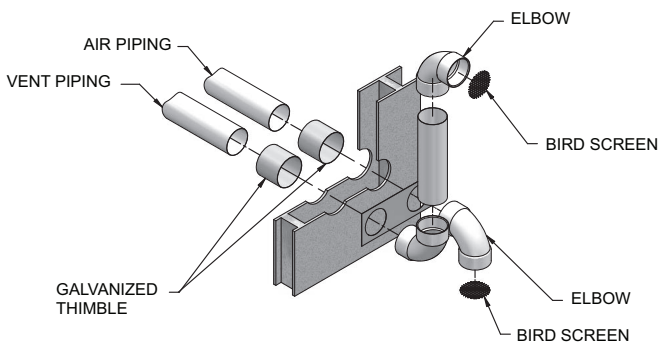

**Figure 3-5A** Multiple Vent Terminations (must also comply with Figure 3-1A)

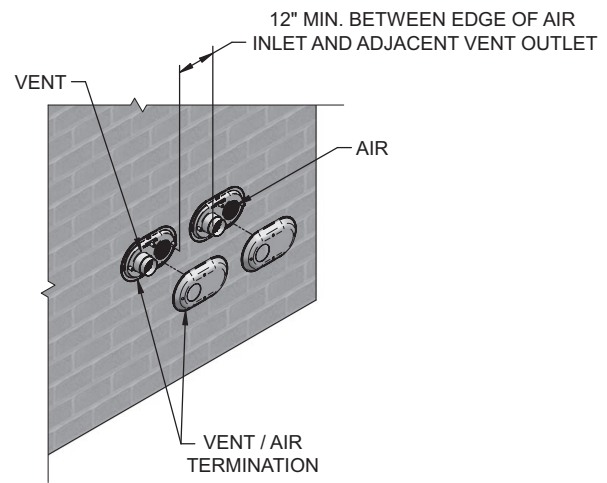

**Figure 3-5B** Alternate Multiple Vent Terminations w/Field Supplied Fittings (must also comply with Figure 3-1B)

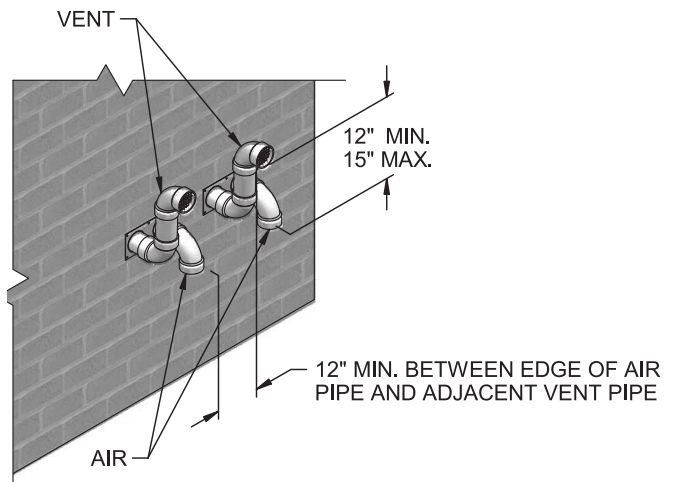

#### Multiple vent/air terminations

- When terminating multiple Shield water heaters terminate each vent/air connection as described in this manual (FIG. 3-5A).

**⚠ WARNING** All vent pipes and air inlets must terminate at the same height to avoid possibility of severe personal injury, death, or substantial property damage.

- Place wall penetrations to obtain minimum clearance of 12 inches between edge of air inlet and adjacent vent outlet, as shown in FIG. 3-5A for U.S. installations. For Canadian installations, provide clearances required by CSA B149.1 Installation Code.
- The air inlet of a Shield water heater is part of a direct vent connection. It is not classified as a forced air intake with regard to spacing from adjacent water heater vents.

### 3 Sidewall direct venting

#### Sidewall termination – optional concentric vent

##### Description and usage

Lochinvar offers optional concentric combustion air and vent pipe termination kits (Factory Kit #100140480 for 3" diameter - Models 125 - 200 and #100140484 for 4" diameter - Models 285 - 500). Both combustion air and vent pipes must attach to the termination kit. The termination kits must terminate outside the structure and must be installed as shown in FIG. 3-6.

The required combustion vent pipe materials are listed in Table 2C, on page 20 of this manual.

**Figure 3-6 Concentric Sidewall Termination**

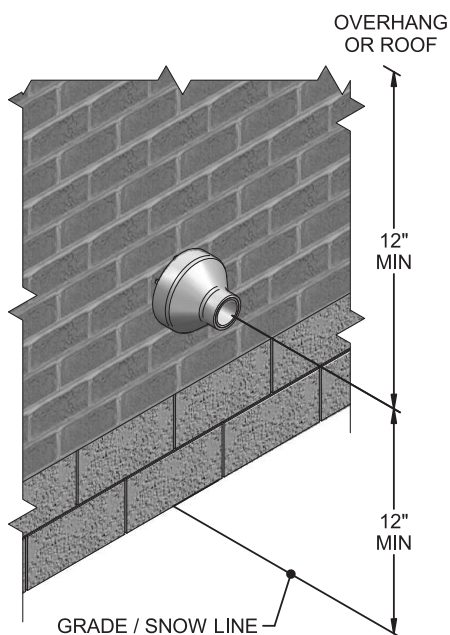

##### Sidewall termination installation

- Determine the best location for the termination kit (see FIG. 4-6).
- Reference the *Determine Location Section* on page 23 of this manual for general termination considerations.
- Cut one (1) hole (5 inch diameter for #100140480 installations or 7 inch diameter for #100140484 installations) into the structure to install the termination kit.
- Partially assemble the concentric vent termination kit. Clean and cement using the procedures found in these instructions.
  - Cement the Y concentric fitting to the larger kit pipe (FIG.'s 3-7 and 3-8).
  - Cement the rain cap to the smaller diameter kit pipe (FIG.'s 3-7 and 3-8).

**Figure 3-7 Kit Contents\_100140480 - 125 -- 200**

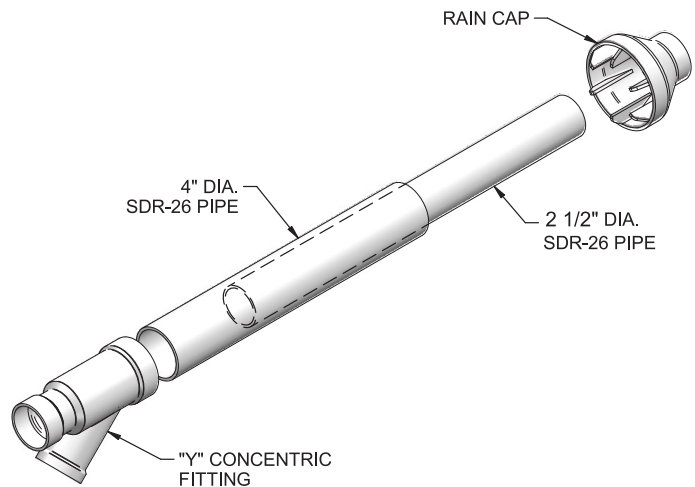

**Figure 3-8 Kit Contents\_100140484 - 285 -- 500**

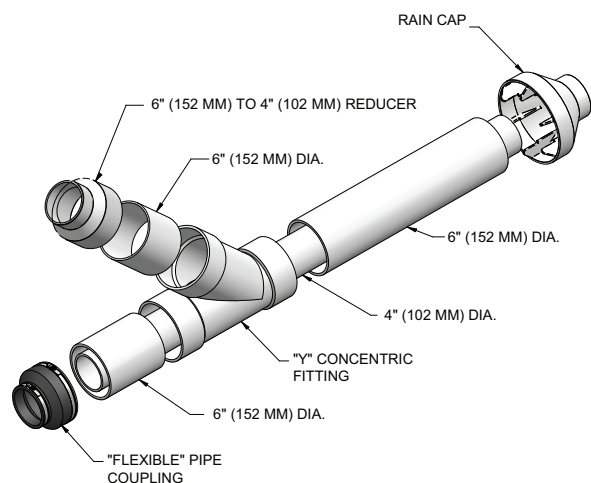

**Table 3E Alternate Centrotherm Concentric Vent Terminations**

Roof Terminations	
Size	Part No.
3"	ICRT3539
4"	ICRT4679
Wall Terminations	
Size	Part No.
3"	ICWT352
4"	ICWT462

### 3 Sidewall direct venting *(continued)*

#### Sidewall termination – optional concentric vent

**Figure 3-9 Concentric Vent Dimensional Drawing - Models 125 -- 200 / 100140480**

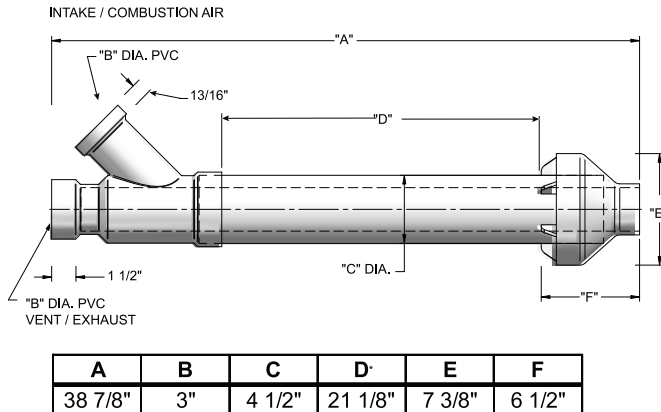

#### NOTICE

Instead of cementing the smaller pipe to the rain cap, a field-supplied stainless steel screw may be used to secure the two (2) components together when field disassembly is desired for cleaning (see FIG. 3-11).

#### WARNING

When using the alternate screw assembly method, drill a clearance hole in the rain cap and a pilot hole in the vent pipe for the screw size being used. Failure to drill adequate holes may cause cracking of PVC components, allowing combustion products to be recirculated. Failure to follow this warning could result in personal injury or death.

#### WARNING

Do not operate the appliance with the rain cap removed or recirculation of combustion products may occur. Water may also collect inside the larger combustion air pipe and flow to the burner enclosure. Failure to follow this warning could result in product damage or improper operation, personal injury, or death.

**Figure 3-11 Rain Cap to Vent Pipe Alternate Assembly**

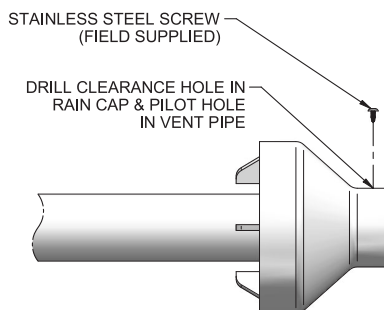

**Figure 3-10 Concentric Vent Dimensional Drawing - Models 285 -- 500 / 100140484**

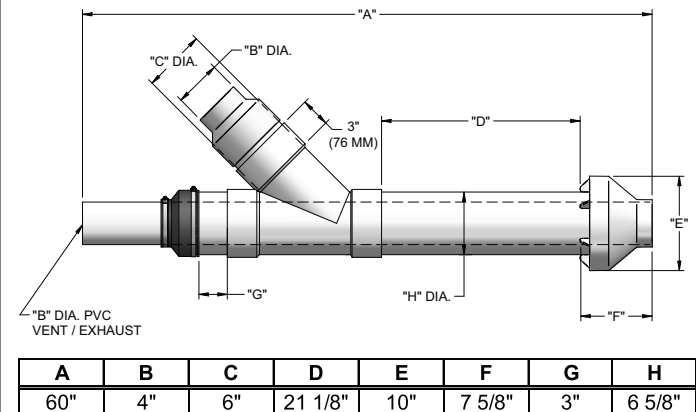

- Install the Y concentric fitting and pipe assembly through the structure's hole.

#### NOTICE

Do not allow insulation or other materials to accumulate inside the pipe assembly when installing through the hole.

- Install the rain cap and small diameter pipe assembly into the Y concentric fitting and large pipe assembly. Ensure small diameter pipe is bottomed and cemented in the Y concentric fitting for #100140480 installations and fastened tightly into the rubber adapter for #100140484 installations.
- Secure the assembly to the structure as shown in FIG. 3-12 using field-supplied metal strapping or equivalent support material.

#### NOTICE

Ensure termination location clearance dimensions are as shown in FIG. 3-6.

#### NOTICE

If assembly needs to be extended to allow sidewall thickness requirement, the two (2) pipes supplied in the kit may be replaced by using the same diameter, field-supplied SDR-26 PVC (D2241) pipe for 100140480 and standard schedule 40 PVC for 100140484. Do not extend dimension D\* more than 60 inches (see FIG.'s 3-9 and 3-10).

#### NOTICE

If assembly depth needs to be reduced, dimension D can be as short as possible.

### 3 Sidewall direct venting

#### Sidewall termination – optional concentric vent

Figure 3-12 Concentric Vent Sidewall Attachment

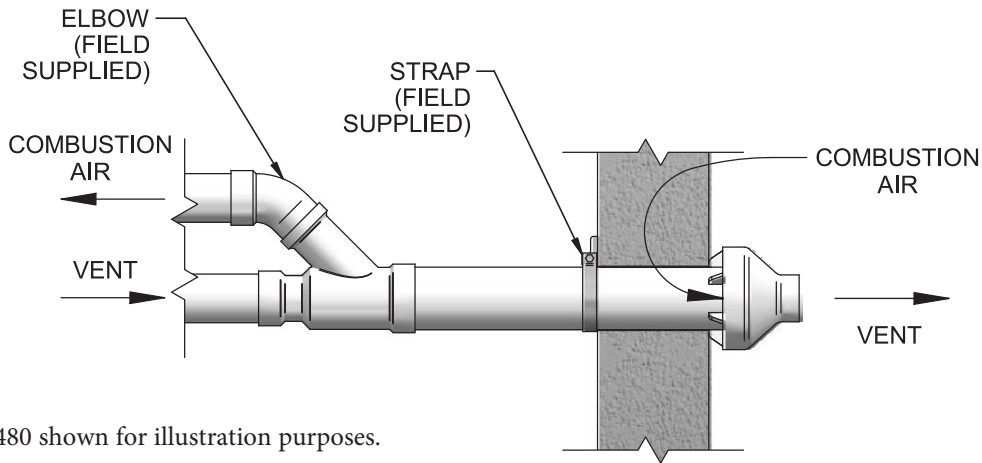

Note: 100140480 shown for illustration purposes.

#### CAUTION

DO NOT use field-supplied couplings to extend pipes. Airflow restriction will occur and may cause intermittent operation.

9. Cement appliance combustion air and vent pipes to the concentric vent termination assembly. See FIG. 3-12 for proper pipe attachment.
10. Operate the appliance one (1) heat cycle to ensure combustion air and vent pipes are properly connected to the concentric vent termination connections.

#### Multiventing sidewall terminations

When two (2) or more direct vent appliances are vented near each other, each appliance must be individually vented (see FIG. 3-13). NEVER common vent or breach vent this appliance. When two (2) or more direct vent appliances are vented near each other, two (2) vent terminations may be installed as shown in FIG. 3-13. It is important that vent terminations be made as shown to avoid recirculation of flue gases.

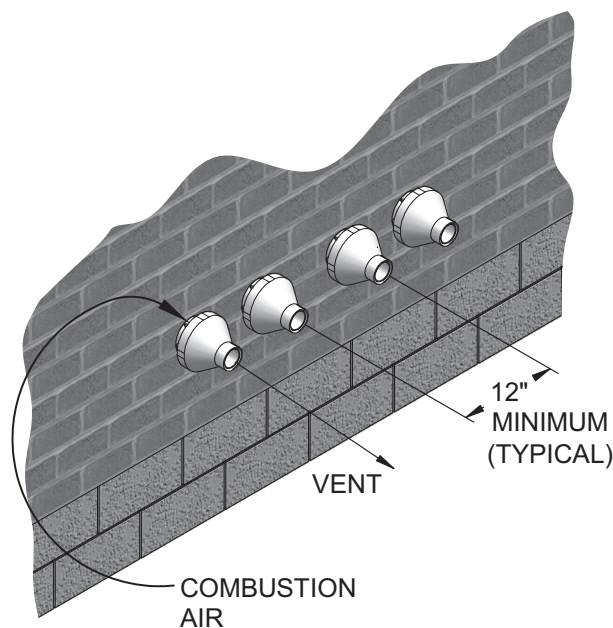

Figure 3-13 Concentric Vent and Combustion Air Termination



## 4 Vertical direct venting

### Vent/air termination – vertical

**⚠ WARNING** Follow instructions below when determining vent location to avoid possibility of severe personal injury, death or substantial property damage.

#### Determine location

Locate the vent/air terminations using the following guidelines:

1. The total length of piping for vent or air must not exceed the limits given in the General Venting Section on page 17 of this manual.
2. Prepare the vent termination and the air termination elbow (FIG. 4-1A) by inserting bird screens. Bird screens should be obtained locally.
3. The vent must terminate at least 3 feet above the highest place in which the vent penetrates the roof and at least 2 feet above any part of a building within 10 horizontal feet.
4. The air piping must terminate in a down-turned 180° return pipe no further than 2 feet from the center of the vent pipe. This placement avoids recirculation of flue products into the combustion air stream.
5. The vent piping must terminate in an up-turned coupling as shown in FIG. 4-1A. The top of the coupling must be at least 1 foot above the air intake. When the vent termination uses a rain cap as illustrated in FIG. 4-1B maintain at least 36" (914 mm) above the air inlet. The air inlet pipe and vent pipe can be located in any desired position on the roof, but must always be no further than 2 feet (.6 m) apart and with the vent termination at least 1 foot for PVC and 3 feet for stainless steel, above the air intake.
6. Maintain the required dimensions of the finished termination piping as shown in FIG. 4-1A.
7. Do not extend exposed vent pipe outside of building more than shown in this document. Condensate could freeze and block vent pipe.

**⚠ WARNING** Rooftop vent and air inlet terminations must terminate in the same pressure zone, unless vertical vent sidewall air is set up as shown in the General Venting - Vertical Vent, Sidewall Air Section.

**Figure 4-1A Vertical Termination of Air and Vent**

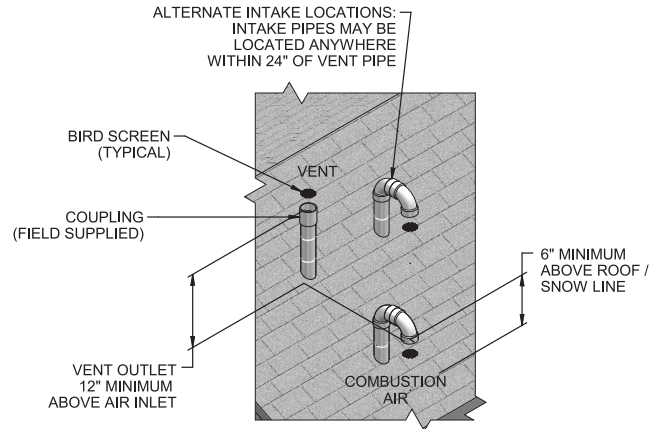

**Figure 4-1B Stainless Steel Vertical Termination of Air and Vent**

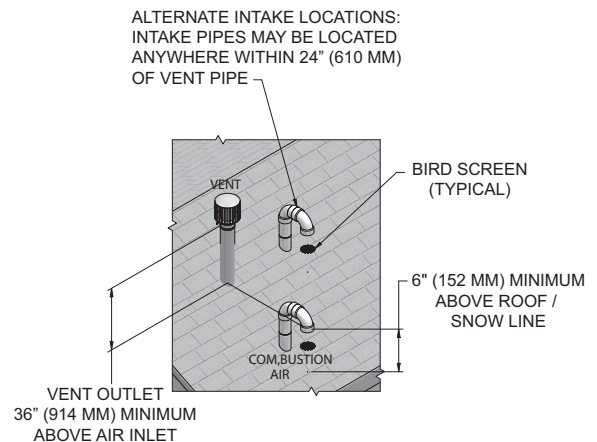

8. Locate terminations so they are not likely to be damaged by foreign objects, such as stones or balls, or subject to buildup of leaves or sediment.

## 4 Vertical direct venting

### Vent/air termination – vertical

#### Prepare roof penetrations

1. Air pipe penetration:
  - a. Cut a hole for the air pipe. Size the air pipe hole as close as desired to the air pipe outside diameter.
2. Vent pipe penetration:
  - a. Cut a hole for the vent pipe. For either combustible or noncombustible construction, size the vent pipe hole with at least a 1/2 inch clearance around the vent pipe outer diameter:
    - 4½ inch hole for 3 inch vent pipe
    - 5½ inch hole for 4 inch vent pipe
  - b. Insert a galvanized metal thimble in the vent pipe hole.
3. Space the air and vent holes to provide the minimum spacing shown in FIG. 4-1A, page 33.
4. Follow all local codes for isolation of vent pipe when passing through floors, ceilings, and roofs.
5. Provide flashing and sealing boots sized for the vent pipe and air pipe.

#### Multiple vent/air terminations

1. When terminating multiple Shield water heaters, terminate each vent/air connection as described in this manual (FIG. 4-2).

#### **WARNING**

Terminate all vent pipes at the same height and all air pipes at the same height to avoid possibility of severe personal injury, death, or substantial property damage.

2. Place roof penetrations to obtain minimum clearance of 12 inches between edge of air intake elbow and adjacent vent pipe of another water heater for U.S. installations (see FIG. 4-2). For Canadian installations, provide clearances required by CSA B149.1 Installation Code.
3. The air inlet of a Shield water heater is part of a direct vent connection. It is not classified as a forced air intake with regard to spacing from adjacent water heater vents.

**Figure 4-2 Vertical Terminations with Multiple Water Heaters**

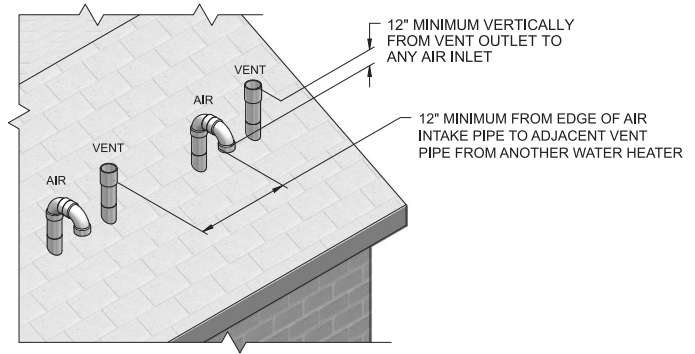

**Figure 4-3 Alternate Vertical Terminations with Multiple Water Heaters**

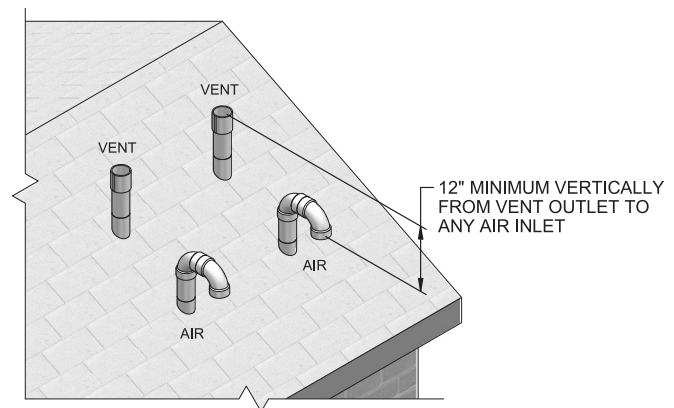

## 4 Vertical direct venting *(continued)*

### Vertical termination – optional concentric vent

#### Description and usage

Lochinvar offers an optional concentric combustion air and vent pipe termination kit. Both combustion air and vent pipes must attach to the termination kit. The termination kit must terminate outside the structure and must be installed as shown in FIG. 4-4.

Field supplied pipe and fittings are required to complete the installation.

The required combustion air and vent pipe fittings are listed in Table 2C, on page 20 of this manual.

#### Vertical termination installation

1. See Section 4, Vertical Direct Venting - Determine Location (where applicable).

2. Cut one (1) hole (5 inch diameter for #100140480 installations or 7 inch diameter for #100140484 installations) into the structure to install the termination kit.
3. Partially assemble the concentric vent termination kit. Clean and cement following the cleaning procedures in these instructions.
  - a. Cement the Y concentric fitting to the larger diameter kit pipe (see FIG.'s 3-7 and 3-8, page 30).
  - b. Cement rain cap to the smaller diameter kit pipe (see FIG.'s 3-7 and 3-8, page 30).
  - c. Do not attach a U-Bent to the rain cap. Doing so could cause recirculation (see FIG. 4-5).

**Figure 4-4** Concentric Vertical Termination

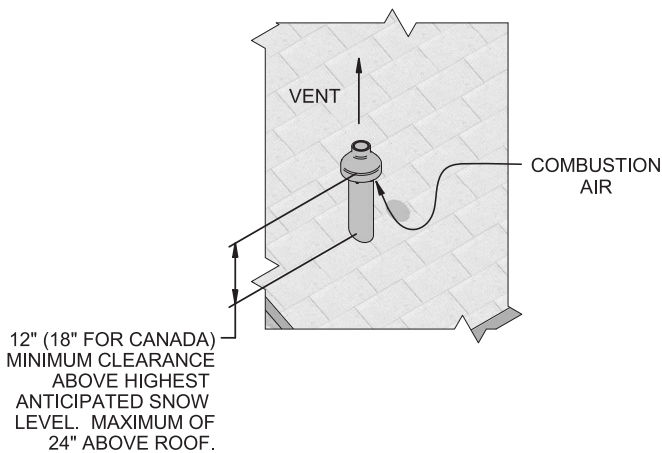

#### NOTICE

Instead of cementing the smaller pipe to the rain cap, a field supplied stainless steel screw may be used to secure the two (2) components together when field disassembly is desired for cleaning (see FIG. 3-11, page 31).

#### WARNING

When using the alternate screw assembly method, drill a clearance hole in the rain cap and a pilot hole in the vent pipe for the screw size being used. Failure to drill adequate holes may cause cracking of PVC components, allowing combustion products to be recirculated. Failure to follow this warning could result in personal injury or death.

**Figure 4-5** Do Not Install U-Bent to Rain Cap



## 4 Vertical direct venting

### Vertical termination – optional concentric vent

#### ⚠ WARNING

Do not operate the appliance with the rain cap removed or recirculation of combustion products may occur. Water may also collect inside the larger combustion air pipe and flow to the burner enclosure. Failure to follow this warning could result in product damage or improper operation, personal injury, or death.

4. Install the Y concentric fitting pipe assembly up through the structure's hole and field supplied roof boot/flashing.

#### NOTICE

Do not allow insulation or other materials to accumulate inside the pipe assembly when installing through the hole.

5. Secure the assembly to the roof structure as shown below in FIG. 4-6 using field supplied metal strapping or equivalent support material.

#### CAUTION

DO NOT use field-supplied couplings to extend pipes. Airflow restriction will occur.

6. Install the rain cap and the small diameter pipe assembly into the roof penetration assembly. Ensure the small diameter pipe is cemented and bottomed in the Y concentric fitting for #100140480 installations and fastened tightly into the rubber adapter for #100140484 installations.
7. Cement the appliance combustion air and vent pipes to the concentric vent termination assembly. See FIG. 4-6 for proper pipe attachment.
8. Operate the appliance through one (1) heat cycle to ensure combustion air and vent pipes are properly connected to the concentric vent termination connections.

### Multiventing vertical terminations

When two (2) or more direct vent appliances are vented near each other, each appliance must be individually vented (see FIG. 4-7). NEVER common vent or breach vent this appliance. When two (2) or more direct vent appliances are vented near each other, two (2) vent terminations may be installed as shown in FIG. 4-7. It is important that vent terminations be made as shown to avoid recirculation of flue gases.

**Figure 4-6 Concentric Vent Roof Installation**

**Note:** 100140480 shown for illustration purposes.

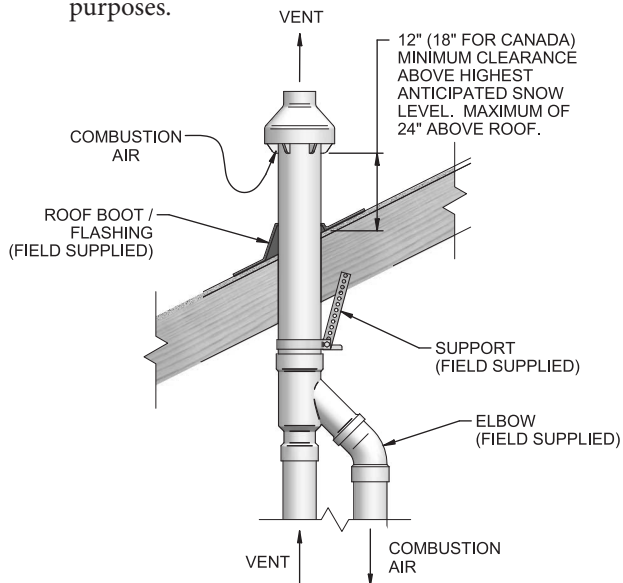

#### NOTICE

Ensure termination height is above the roof surface or anticipated snow level (12 inches in U.S.A. or 18 inches in Canada) as shown in FIG. 4-4, page 35.

#### NOTICE

If assembly is too short to meet height requirement, the two (2) pipes supplied in the kit may be replaced by using the same diameter, field supplied SDR-26 PVC (D2241) pipe for #100140480 and standard schedule 40 PVC for #100140484. Do not extend dimension D\* more than 60 inches (see FIG.'s 3-9 and 3-10, page 31).

**Figure 4-7 Concentric Vent and Combustion Air Vertical Termination**

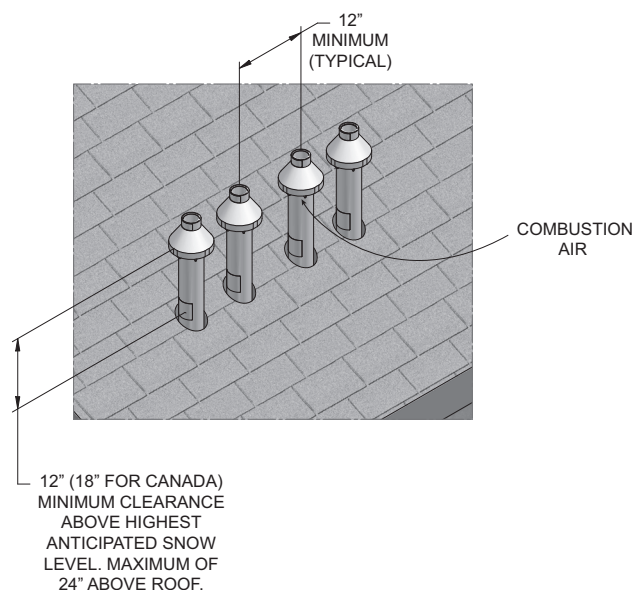

## 5 System piping

### System water piping methods

Observe a minimum of one inch clearance around all un-insulated hot water pipes when openings around the pipes are not protected by non-combustible materials.

#### ⚠ WARNING

Failure to install and maintain a new, listed temperature and pressure relief valve will release the manufacturer from any claim, which might result from excessive temperature and pressures.

Keep clear of the combination temperature and pressure relief valve discharge line outlet. The discharge may be hot enough to cause scald injury. The water is under pressure and may splash.

Hydrogen gas can be produced in an operating water heater that has not had water drawn from the tank for a long period of time (generally two weeks or more). HYDROGEN GAS IS EXTREMELY FLAMMABLE. To prevent the possibility of injury under these conditions, we recommend the hot water faucet to be open for several minutes at the kitchen sink before you use any electrical appliance, which is connected to the hot water system. If hydrogen is present, there will be an unusual sound such as air escaping through the pipes as hot water begins to flow. Do not smoke or have an open flame near the faucet at the time it is open.

### General piping information

Basic steps are listed below along with illustrations on the following pages (FIG.'s 5-2 thru 5-4), which will guide you through the installation of the Shield water heater.

1. BEFORE PROCEEDING WITH THE INSTALLATION, CLOSE THE MAIN WATER SUPPLY VALVE. After shutting off the main water supply, open a faucet to relieve the water line pressure to prevent any water from leaking out of the pipes while making the water connections to the water heater. The COLD water inlet and HOT water outlet are identified on the water heater. Make the proper plumbing connections between the water heater and the plumbing system to the building. Install a shutoff valve in the cold water supply line.

2. If this water heater is installed in a closed water supply system, such as the one having a backflow preventer in the cold water supply, provisions must be made to control thermal expansion. DO NOT operate this water heater in a closed system without provisions for controlling thermal expansion such as pressure bulges and/or deformities. Your water supplier or local plumbing inspector should be contacted on how to control this situation.
3. After installation of the water lines, open the main water supply valve and fill the water heater. While the water heater is filling, open several hot water faucets to allow air to escape from the water system. When a steady stream of water flows through the faucets, close them and check all water connections for possible leaks. Manually open the relief valve located on the top of the unit to purge the air from the heat exchanger. When a steady stream of water flows through the relief valve, close it and check all water connections for leaks.
4. Never operate the water heater without first being certain it is filled with water.

### Scalding

This water heater can deliver scalding temperature water at any faucet in the system. Be careful whenever using hot water to avoid scalding injury. Certain appliances such as dishwashers and automatic clothes washers may require increased temperature water. By setting the thermostat on this water heater to obtain the increased temperature water required by these appliances, you may create the potential for scald injury. To protect against injury, you should install an ASSE approved mixing valve in the water system. This valve will reduce point of discharge temperature by mixing cold and hot water in branch supply lines. Such valves are available from the local plumbing supplier.

Figure 5-1 Scald Warning



Water temperatures over 125°F (52°C) can cause severe burns instantly or death from scalds. Children, disabled, and elderly are at highest risk of being scalded.

See instruction manual before setting the thermostat at the water heater.

Feel water before bathing or showering.

Temperature limiting valves are available, consult local plumbing supplier.

## 5 System piping

The following chart (Table 5A) details the relationship of water temperature and time with regard to scald injury and may be used as a guide in determining the safest water temperature for your applications.

**Table 5A Approximate Time / Temperature Scald Chart**

APPROXIMATE TIME / TEMPERATURE RELATIONSHIPS IN SCALDS	
120°F	More than 5 minutes
125°F	1 1/2 to 2 minutes
130°F	About 30 seconds
135°F	About 10 seconds
140°F	Less than 5 seconds
145°F	Less than 3 seconds
150°F	About 1 1/2 seconds
155°F	About 1 second

### Water chemistry

#### NOTICE

The required temperature rise and the standard circulating pump are sized based on the heating of potable water with a specified water chemistry. See Table 9A in Start-Up Section for recommendations.

Water with a hardness of less than 5 grains per gallon will usually have a pH which can be aggressive and corrosive causing non-warrantable damage to the pump and associated piping. Corrosion due to water chemistry generally shows up first in the hot water system because heated water increases the rate of corrosive chemical reactions.

### Piping components

#### Check valves:

Field supplied. Check valves are recommended for installation as shown in FIG.'s 5-2 thru 5-4.

#### Water heater isolation valves:

Field supplied. Full port ball valves are required. Failure to use full port ball valves could result in a restricted flow rate through the water heater.

#### Anti-scald mixing valve:

Field supplied. An anti-scald mixing valve is recommended when storing domestic hot water above 115°F.

#### Unions:

Field supplied. Recommended for unit serviceability.

#### Temperature and pressure relief valve:

Factory supplied on water heaters. The temperature and pressure relief valve is sized to ASME specifications.

#### Strainer:

Field supplied. Required to help eliminate debris from causing damage to the heat exchanger. When installing in a pre-existing system, it is recommended to install a filter in the recirculation line capable of removing debris left in the system.

#### Building Recirculation Filter:

Field supplied as required (see Table 9C). When required, helps to eliminate debris from causing damage to the heat exchanger.

#### ⚠ CAUTION

Check recirculation pump size to verify it is sized for filter addition and upsize if necessary.

#### ⚠ CAUTION

No valves shall be placed between the relief valve, heat exchanger, or tank. The relief valve shall be piped to a suitable drain as close as possible to the heater with no reducing couplings or other restrictions. The piping must be sloping away from the heater at all times.

See the \* piping illustrations included in this section, FIG.'s 5-2 thru 5-4 for suggested guidelines in piping the Shield water heater.

#### NOTICE

\*Please note that these illustrations are meant to show system piping concept only, the installer is responsible for all equipment and detailing required by local codes.

## 5 System piping *(continued)*

Figure 5-2 Single Unit

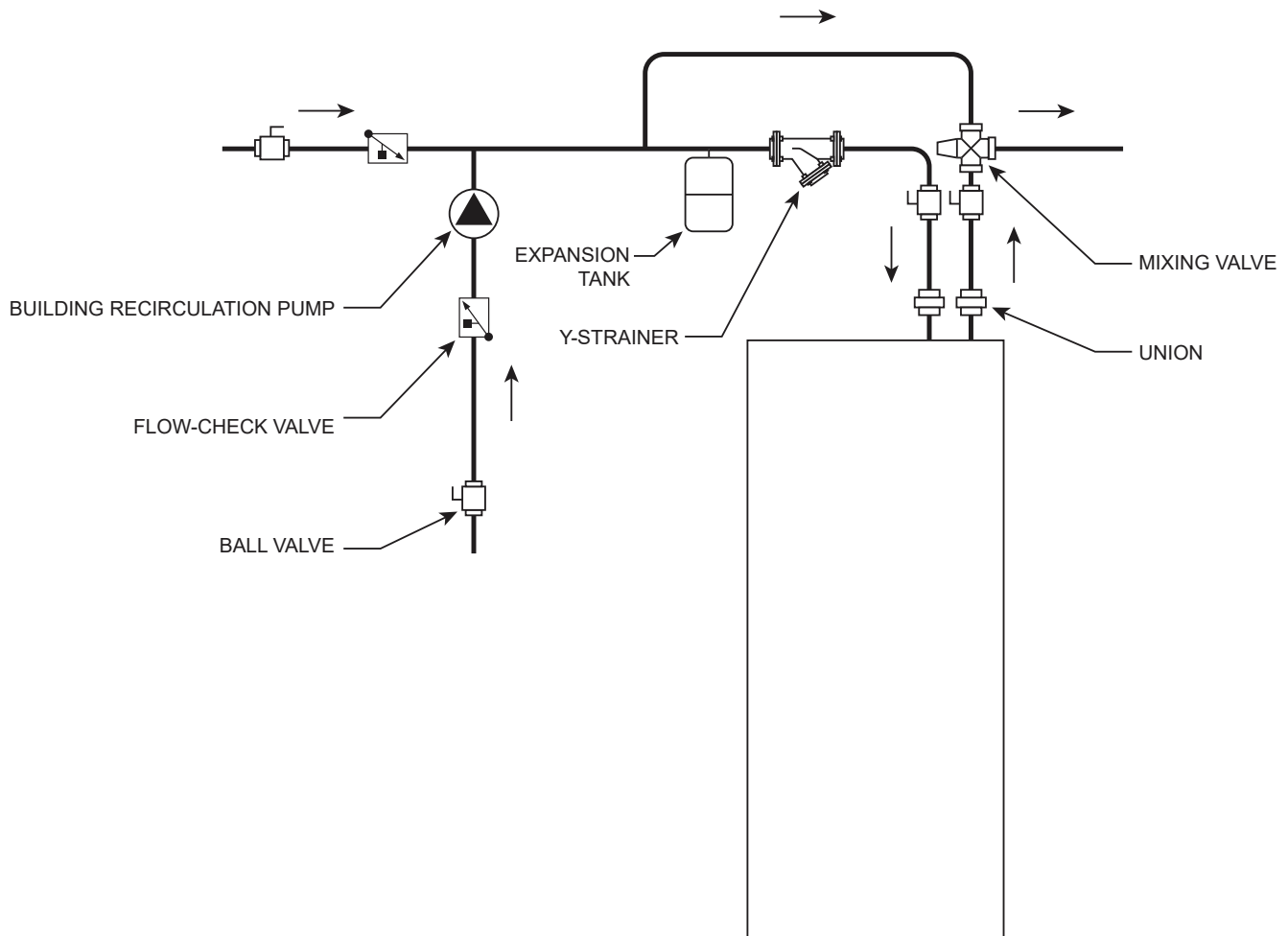

DIR # 2000587161

**NOTICE**

Please note that these illustrations are meant to show system piping concept only, the installer is responsible for all equipment and detailing required by local codes.

## 5 System piping

Figure 5-3 Multiple Units

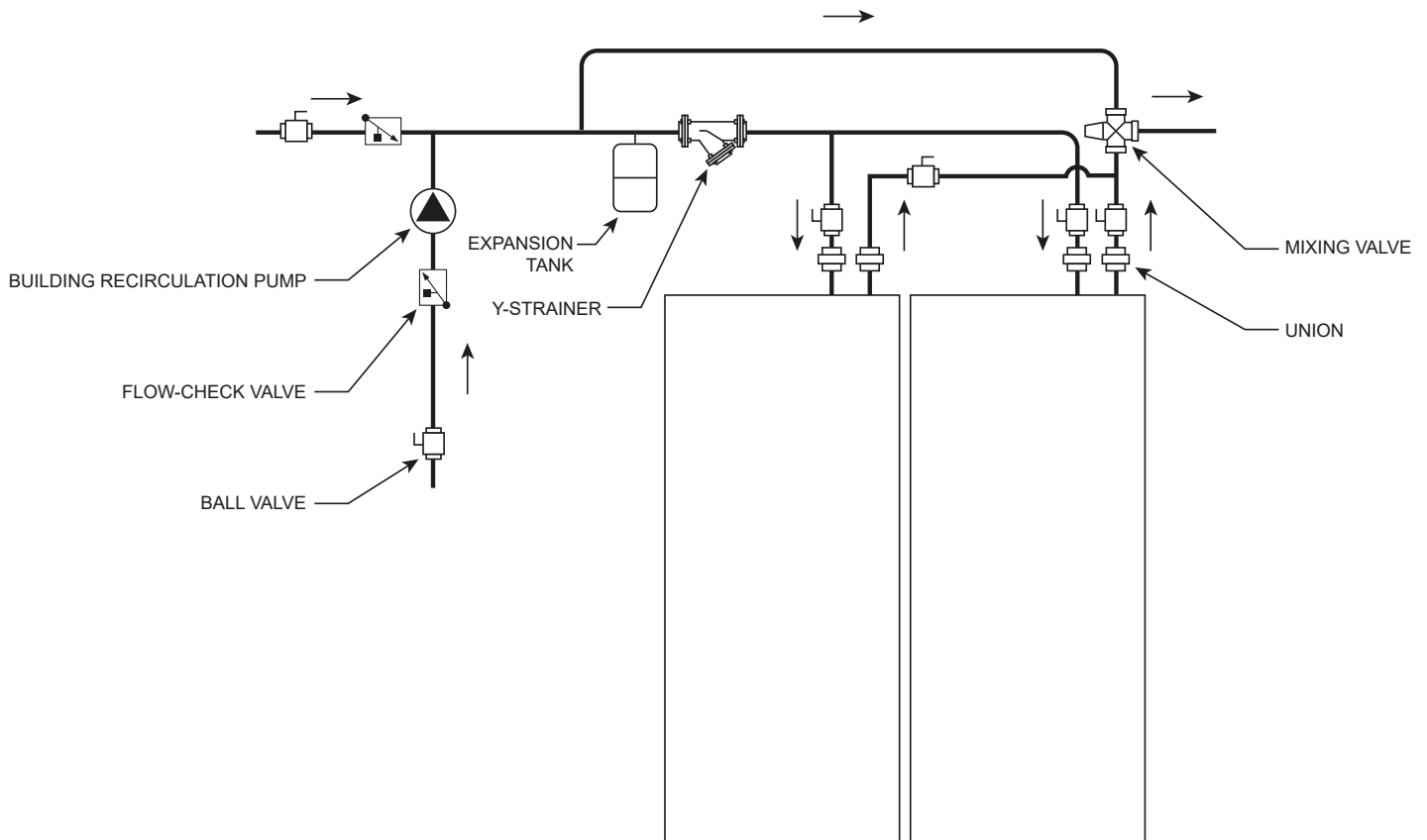

DIR # 2000587161

**NOTICE**

Please note that these illustrations are meant to show system piping concept only, the installer is responsible for all equipment and detailing required by local codes.



## 5 System piping *(continued)*

Figure 5-4 Two Temperature - Single Unit

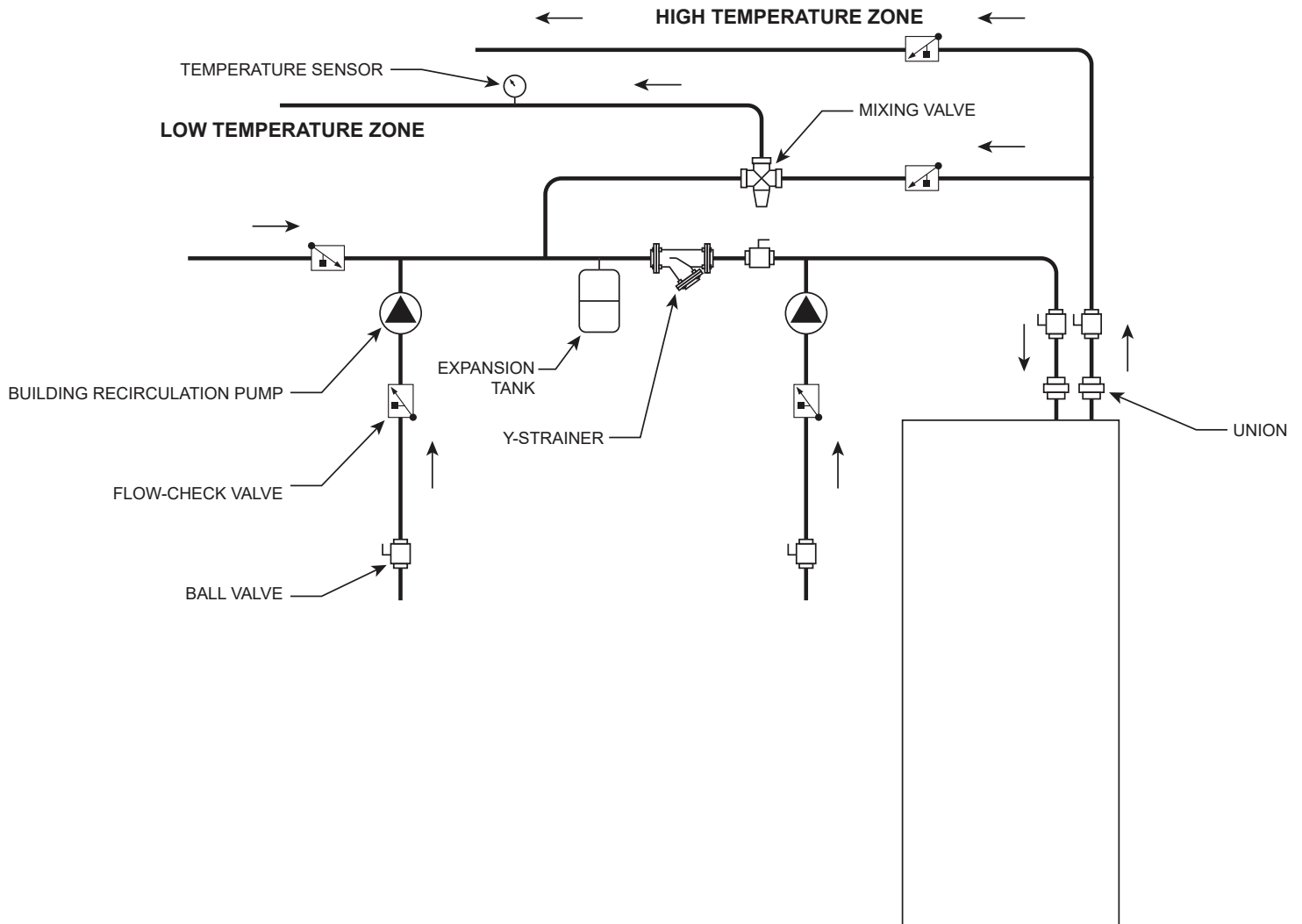

DIR # 2000587161

**NOTICE**

Please note that these illustrations are meant to show system piping concept only, the installer is responsible for all equipment and detailing required by local codes.

## 6 Gas connections

### Connecting gas supply piping

1. Install ground joint union for servicing, when required.
2. On Models 125 -- 285 install a manual shutoff valve in the gas supply piping outside water heater jacket when required by local codes or utility requirements.
3. In Canada – When using manual main shutoff valves, it must be identified by the installer.
4. Support piping with hangers, not by the water heater or its accessories.

#### ⚠ WARNING

The gas valve and blower will not support the weight of the piping. Do not attempt to support the weight of the piping with the water heater or its accessories. Failure to comply could result in severe personal injury, death, or substantial property damage.

**Figure 6-1 Gas Supply Piping - Models 125 -- 285**

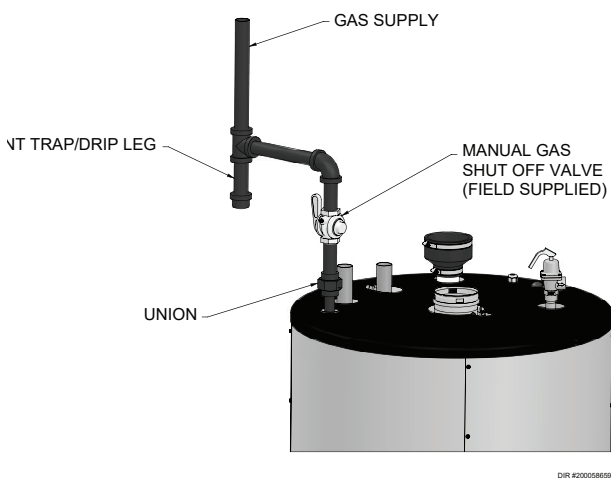

DIR #200058695

**Figure 6-2 Gas Supply Piping - Models 400 -- 500**

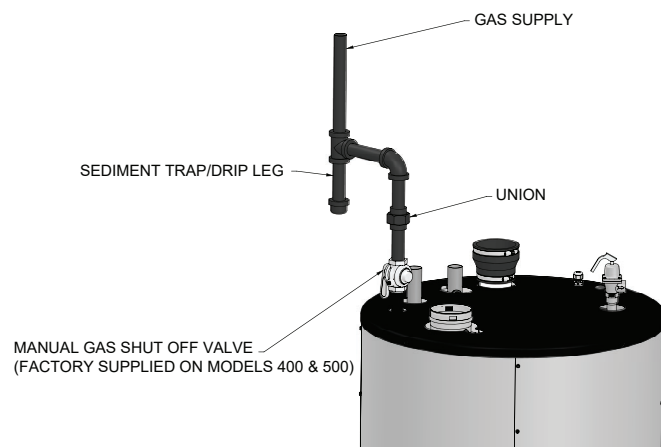

DIR #200058604

5. Purge all air from the gas supply piping.
6. Before placing the water heater in operation, check the water heater and its gas connection for leaks.
  - a. The appliance must be disconnected from the gas supply piping system during any pressure testing of that system at a test pressure in excess of 1/2 PSIG (3.5 kPa).
  - b. The appliance must be isolated from the gas supply piping system by closing a manual shutoff valve during any pressure testing of the gas supply piping system at test pressures equal to or less than 1/2 PSIG (3.5 kPa).
  - c. The appliance and its gas connection must be leak tested before placing it in operation.

#### ⚠ WARNING

Do not check for gas leaks with an open flame – use the bubble test. Failure to use the bubble test or check for gas leaks can cause severe personal injury, death, or substantial property damage.

7. Use pipe sealing compound compatible with propane gases. Apply sparingly only to male threads of the pipe joints so that pipe dope does not block gas flow.

## 6 Gas connections *(continued)*

**⚠ WARNING** Failure to apply pipe sealing compound as detailed in this manual can result in severe personal injury, death, or substantial property damage.

**⚠ WARNING** Shield water heaters are typically shipped ready to fire on natural gas. Check the water heater rating plate to determine which fuel the water heater is set for. In order to operate on LP gas contact the factory, an orifice **MUST BE** installed or a gas valve adjustment **MUST BE** made. Failure to comply could result in severe personal injury, death, or substantial property damage.

**⚠ WARNING** Use two wrenches when tightening gas piping at water heater (FIG. 6-3), using one wrench to prevent the water heater gas line connection from turning. Failure to support the water heater gas connection pipe to prevent it from turning could damage gas line components.

**Figure 6-3 Inlet Pipe with Backup Wrench**

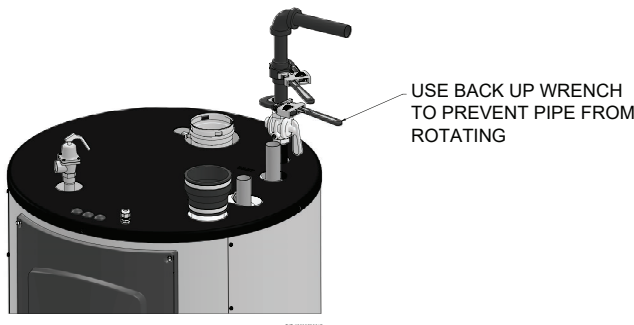

**NOTICE** Maximum inlet gas pressure must not exceed the value specified. Minimum value listed is for the purposes of input adjustment.

**⚠ WARNING** Ensure that the high gas pressure regulator is at least 10 feet upstream of the appliance.

### Natural gas:

#### Pipe sizing for natural gas

1. Refer to Table 6A for pipe length and diameter. Based on rated water heater input (divide by 1,000 to obtain cubic feet per hour).
  - a. Table 6A is only for natural gas with specific gravity 0.60 inches, with a pressure drop through the gas piping of 0.30 inches w.c.
  - b. For additional gas pipe sizing information, refer to ANSI Z223.1 (or B149.1 for Canadian installations).

#### Natural gas supply pressure requirements

1. Pressure required at the gas valve inlet pressure port:
  - Maximum 14 inches w.c. with no flow (lockup) or with water heater on.
  - Minimum 4 inches w.c. with gas flowing (verify during water heater startup).
2. Install 100% lockup gas pressure regulator in supply line if inlet pressure can exceed 14 inches w.c. at any time. Adjust lockup regulator for 14 inches w.c. maximum.

### Propane gas:

**⚠ WARNING** Shield water heaters are typically shipped ready to fire on natural gas. Check water heater rating plate to determine which fuel the water heater is set for. In order to operate on LP gas contact the factory, an orifice **MUST BE** installed or a gas valve adjustment **MUST BE** made. Failure to comply could result in severe personal injury, death, or substantial property damage.

#### Pipe sizing for propane gas

1. Contact gas supplier to size pipes, tanks, and 100% lockup gas pressure regulator.

#### Propane Supply Pressure Requirements

1. Adjust propane supply regulator provided by the gas supplier for 14 inches w.c. maximum pressure.
2. Pressure required at gas valve inlet pressure port:
  - Maximum 14 inches w.c. with no flow (lockup) or with water heater on.
  - Minimum 8 inches w.c. with gas flowing (verify during water heater startup).

## 6 Gas connections

**Table 6A Natural Gas Pipe Size Chart**

Capacity of Schedule 40 Metallic Pipe in Cubic Feet of Natural Gas Per Hour (based on .60 specific gravity, 0.30" w.c. pressure drop)														
Pipe Size (Inches)	Length of Pipe in Straight Feet													
	10	20	30	40	50	60	70	80	90	100	125	150	175	200
1/2	131	90	72	62	55	N/A	N/A	N/A	N/A	N/A	N/A	N/A	N/A	N/A
3/4	273	188	151	129	114	104	95	89	83	79	70	63	58	N/A
1	514	353	284	243	215	195	179	167	157	148	131	119	109	102
1 1/4	1,060	726	583	499	442	400	368	343	322	304	269	244	224	209
1 1/2	1,580	1,090	873	747	662	600	552	514	482	455	403	366	336	313
2	3,050	2,090	1,680	1,440	1,280	1,160	1,060	989	928	877	777	704	648	602
2 1/2	4,860	3,340	2,680	2,290	2,030	1,840	1,690	1,580	1,480	1,400	1,240	1,120	1,030	960
3	8,580	5,900	4,740	4,050	3,590	3,260	3,000	2,790	2,610	2,470	2,190	1,980	1,820	1,700
4	17,500	12,000	9,660	8,270	7,330	6,640	6,110	5,680	5,330	5,040	4,460	4,050	3,720	3,460

**⚠ WARNING** Shield water heaters are typically shipped ready to fire on natural gas. Check the water heater rating plate to determine which fuel the water heater is set for. In order to operate on LP gas contact the factory, an orifice **MUST BE** installed or a gas valve adjustment **MUST BE** made. Failure to comply could result in severe personal injury, death, or substantial property damage.

### Check inlet gas supply

#### NOTICE

CSA or UL listed flexible gas connections are acceptable, but you must exercise caution to ensure that the line has adequate capacity to allow your water heater to fire at full rate. Consult with local codes for proper installation or service procedures.

#### ⚠ WARNING

DO NOT attempt to measure gas valve outlet pressure. The gas valve is factory-set for the correct outlet pressure. This setting is suitable for natural gas and propane (when configured for LP), requiring no field adjustment. Attempting to measure the gas valve outlet pressure could result in damage to the valve, causing potential severe personal injury, death, or substantial property damage.

The gas piping must be sized for the proper flow and length of pipe, to avoid excessive pressure drop. Both the gas meter and the gas regulator must be properly sized for the total gas load.

If you experience a pressure drop greater than 1 inch w.c., the meter, regulator, or gas line is undersized or in need of service. Perform the steps below when checking inlet gas supply:

1. Disconnect power from the appliance.
2. Shut off gas to the appliance.
3. Loosen the set screw one (1) full turn from inside the pressure tap on top of the gas valve. Place the tubing of the manometer over the tap once the set screw is loosened as shown in FIG.'s 6-4 thru 6-6.
4. Slowly turn on the gas supply at the field installed manual gas valve.

5. Reconnect power to the appliance.
6. Adjust the temperature set point on the control panel of the electronic control module to call for heat.
7. Observe the gas supply pressure as the burner fires at 100% of rated input. Percent of burner input will be displayed on the control panel.
8. Ensure inlet pressure is within specified range. Minimum and maximum gas supply pressures are specified in this section of the manual.
9. If gas supply pressure is within normal range and no adjustments are needed, proceed on to Step 11.
10. If the gas pressure is out of range, contact the gas utility, gas supplier, qualified installer or service agency to determine the necessary steps to provide proper gas pressure to the control.
11. Disconnect power from the appliance.
12. Shut off the gas to the appliance.
13. Remove the manometer from the pressure tap on top of the gas valve. Re-tighten the set screw inside the pressure tap.

#### ⚠ WARNING

When re-tightening the set screw, be sure to tighten securely to prevent gas leaks.

Do not check for gas leaks with an open flame -- use the bubble test. Failure to use the bubble test or check for gas leaks can cause severe personal injury, death, or substantial property damage.

14. Reconnect gas to the appliance.
15. Reconnect power to the appliance.
16. Adjust the temperature set point on the control panel of the electronic control module to the desired water temperature so the appliance will call for heat.

## 6 Gas connections *(continued)*

17. Check burner performance by cycling the system while you observe burner response. The burner should ignite promptly. Flame pattern should be stable. Turn system off and allow burner to cool, then cycle burner again to ensure proper ignition and flame characteristics.

**Figure 6-4 Inlet Gas Supply Check - Models 125-- 285**

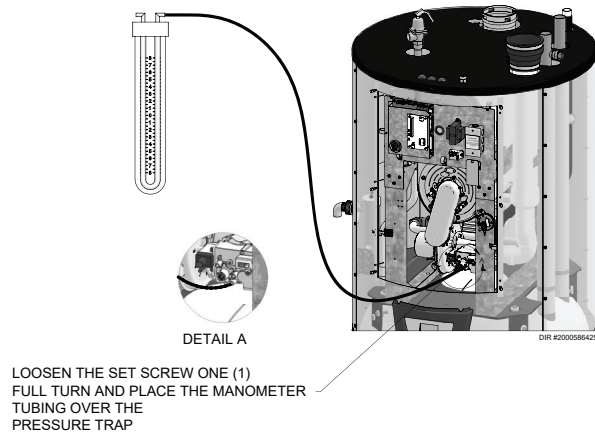

**Figure 6-5 Inlet Gas Supply Check - Model 400**

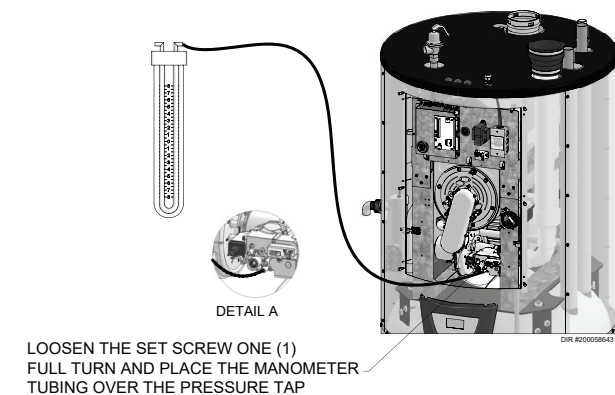

**Figure 6-6 Inlet Gas Supply Check - Model 500**

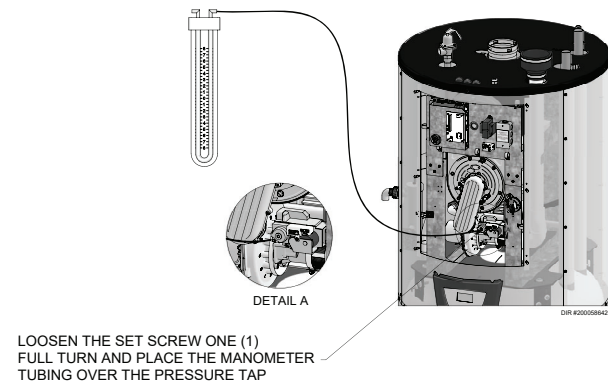

### Gas pressure

The gas pressure must remain between 4 inches w.c. (natural), 8 inches w.c. (LP) minimum and 14 inches w.c. (natural and LP) maximum during stand-by (static) mode and while in operating (dynamic) mode. If a gas pressure regulator is used, it must be a minimum of 10 feet from the Shield water heater. It is very important that the gas line is properly purged by the gas supplier or utility company. Failure to properly purge the lines or improper line sizing, will result in ignition failure.

The problem is especially noticeable in NEW LP installations and also in empty tank situations. This can also occur when a utility company shuts off service to an area to provide maintenance to their lines.

### Gas valve replacement

The gas valve **MUST NOT** be replaced with a conventional gas valve under any circumstances. As an additional safety feature, this gas valve has a flanged connection to the venturi and blower.

#### **WARNING**

Failure to follow all precautions could result in fire, explosion, or death!

#### **WARNING**

DO NOT attempt to measure gas valve outlet pressure. The gas valve is factory-set for the correct outlet pressure. This setting is suitable for natural gas and propane (when configured for LP), requiring no field adjustment. Attempting to measure the gas valve outlet pressure could result in damage to the valve, causing potential severe personal injury, death, or substantial property damage.

## 7 Field wiring

**⚠ WARNING** ELECTRICAL SHOCK HAZARD – For your safety, turn off electrical power supply before making any electrical connections to avoid possible electric shock hazard. Failure to do so can cause severe personal injury or death.

### NOTICE

Wiring must be N.E.C. Class 1.

If original wiring as supplied with the water heater must be replaced, use only type 105°C wire or equivalent.

The water heater must be electrically grounded as required by National Electrical Code ANSI/NFPA 70 – latest edition.

### ⚠ CAUTION

Label all wires prior to disconnection when servicing controls. Wiring errors can cause improper and dangerous operation. Verify proper operation after servicing.

### Low voltage connections

1. Route all low voltage wires through the plugs in the top of the water heater, as shown in FIG. 7-1.
2. Connect low voltage wiring to low voltage connection board as shown in FIG. 7-3 on page 47 of this manual and the water heater wiring diagram.

Figure 7-1 Routing Field Wiring

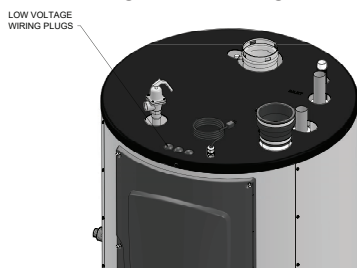

### Enable switch

An external switch or contact may be used to enable/disable the water heater. To connect the enable switch, remove jumper tab "A" on the low voltage connection board and connect the wires from the switch to the correct terminals. Reference Fig 7-3 on page 47 of this manual for appropriate wiring of the switch. If the incorrect tab is removed, a jumper wire may be added across the terminals to take the place of the tab.

### Louver relay output / louver proving switch input

When installed using the optional room air configuration, the heater is able to control powered louvers to allow outside air into the room. Connect the 24VAC control relay to the LOUVER RELAY output on the low voltage connection board. Remove jumper tab "B" on the low voltage connection board and connect the louver proving switch wires to the correct terminals. Reference Fig 7-3 on page 47 of this manual for appropriate wiring of the switch. If the incorrect tab is removed, a jumper wire may be added across the terminals to take the place of the tab.

### Installation must comply with:

1. National Electrical Code and any other national, state, provincial, or local codes, or regulations.
2. In Canada, CSA C22.1 Canadian Electrical Code Part 1, and any local codes.

### Power cord connection

This water heater is designed to operate with 120 VAC and 60 Hz power supply. If allowed by local codes, connect the power cord provided with the heater to a GFI protected outlet on a separate circuit and breaker (15 amp recommended). Ensure the circuit cannot be interrupted by a switch used to control lights or other appliances.

If local codes do not allow for the use of the power cord, remove the cord from the junction box found on the side of the control support bracket (FIG. 7-2) and attach conduit to the junction box. Route the wires out of the appliance to a GFI protected outlet on a separate circuit and breaker (15 amp recommended).

### ⚠ WARNING

Use of an extension cord is NOT allowed. If a suitable electrical outlet is not within reach of the supplied power cord, a new receptacle must be installed or the power cord must be replaced with hard conduit as described above.

Figure 7-2 Remove Power Cord

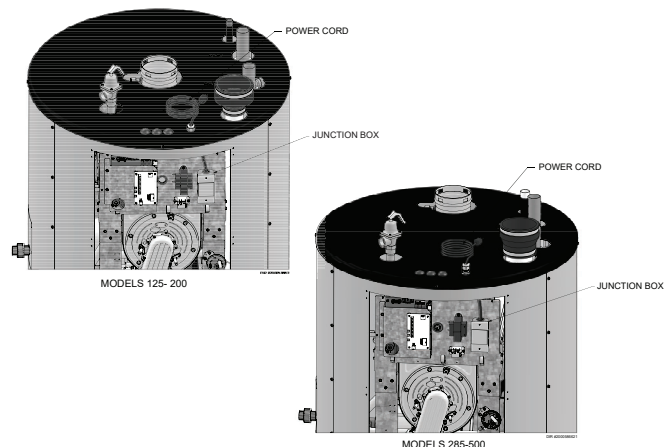

### Runtime contacts

The electronic control closes a set of dry contacts whenever the burner is running. This is typically used by Building Management Systems to verify that the water heater is responding to a call for heat.

### Alarm contacts

The electronic control closes another set of contacts whenever the water heater is locked out or the power is turned off. This can be used to turn on an alarm, or signal a Building Management System that the water heater is down. Note that the alarm contacts will close momentarily after each call for heat.

# 7 Field wiring *(continued)*

Figure 7-3 Low Voltage Field Wiring Connections

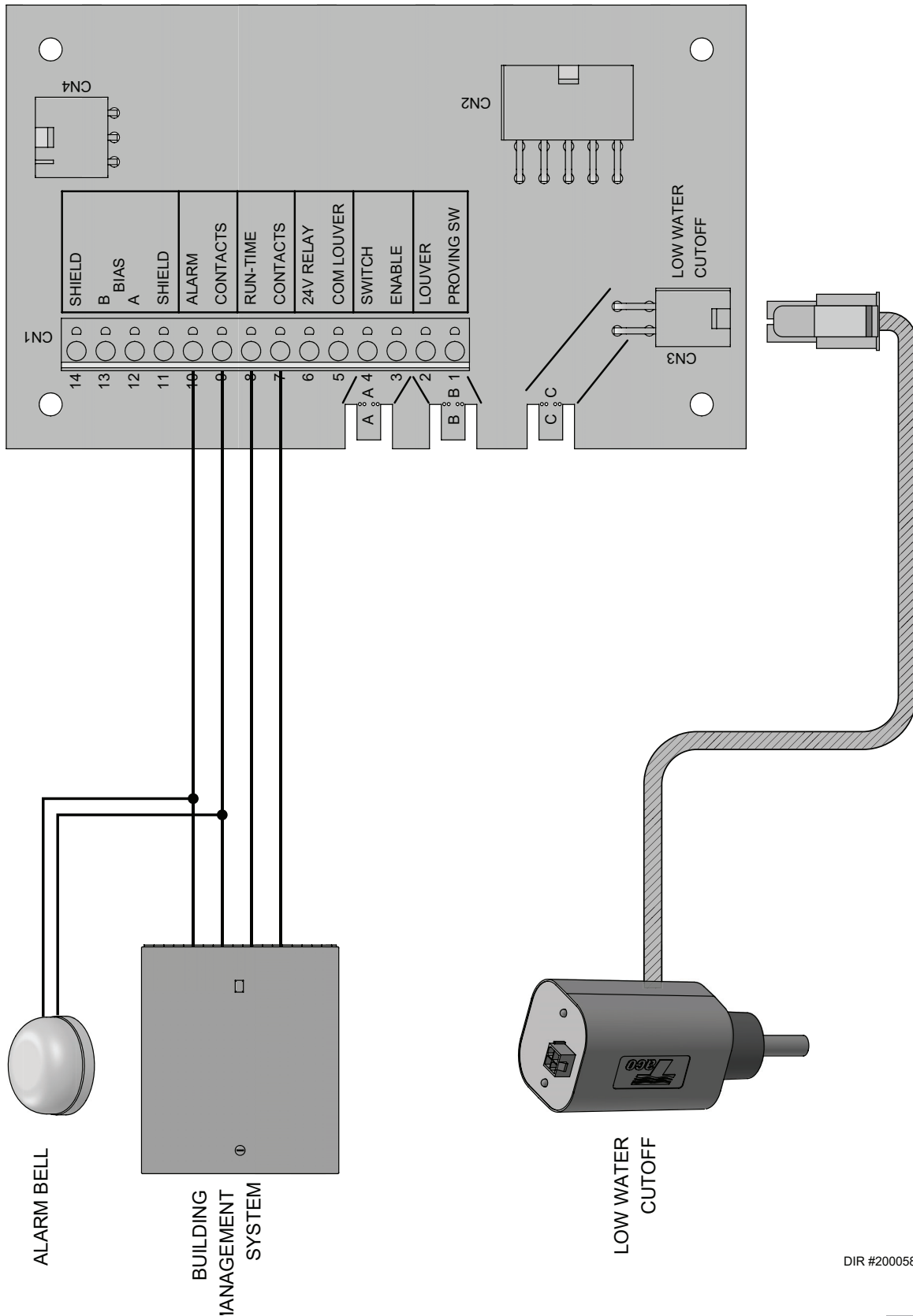

DIR #2000587038

# 7 Field wiring

Figure 7-4 Control Inputs/Outputs

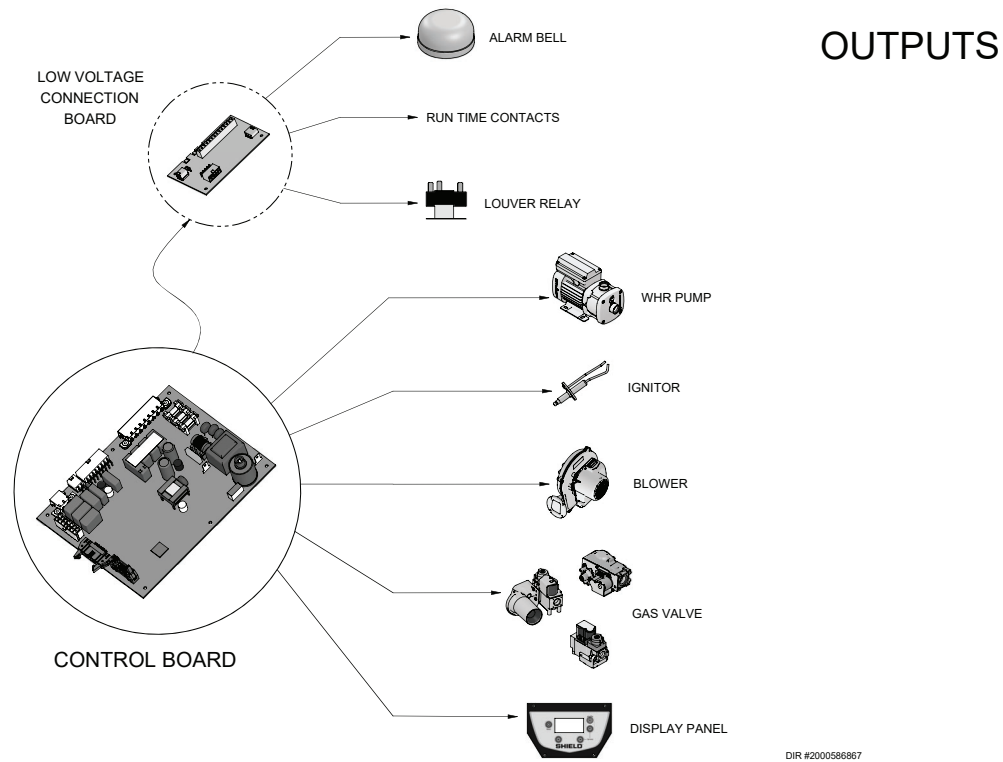
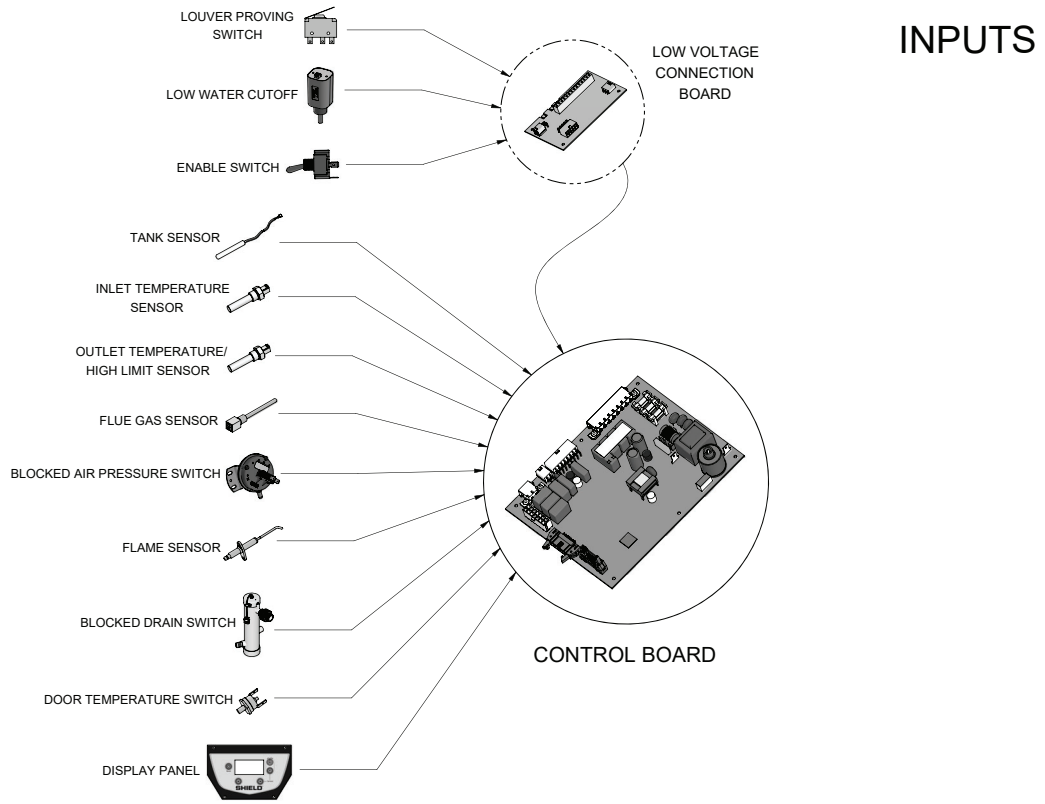



## 8 Condensate disposal

### Condensate drain

1. This water heater is a high efficiency appliance that produces condensate.
2. Slope condensate tubing down and away from the water heater into a drain or condensate neutralizing filter. Condensate from the Shield water heater will be slightly acidic (typically with a pH from 3 to 5). Install a neutralizing filter if required by local codes.

A Neutralizer Kit is available from the factory (100157721).

**Note:** The Neutralizer Kit MUST BE installed horizontally.

3. Do not expose condensate line to freezing temperatures.

#### NOTICE

Use materials approved by the authority having jurisdiction. In the absence of other authority, PVC and CPVC pipe must comply with ASTM D1785 or D2845. Cement and primer must comply with ASME D2564 or F493. For Canada use CSA or ULC certified PVC or CPVC pipe, fittings, and cement.

#### NOTICE

To allow for proper drainage on large horizontal runs, a second line vent may be required and tubing size may need to increase to 1 inch.

The condensate line must remain unobstructed, allowing free flow of condensate. If condensate is allowed to freeze in the line or if the line is obstructed in any other manner, condensate can exit from the water heater condensate trap, resulting in potential water damage to property.

4. A condensate removal pump is required if the water heater is below the drain. When installing a condensate pump, select one approved for use with condensing water heaters and furnaces. The pump should have an overflow switch to prevent property damage from condensate spillage. The switch should be wired to the auxiliary device proving switch terminals on the low voltage connection board.

**Figure 8-1** Condensate Disposal

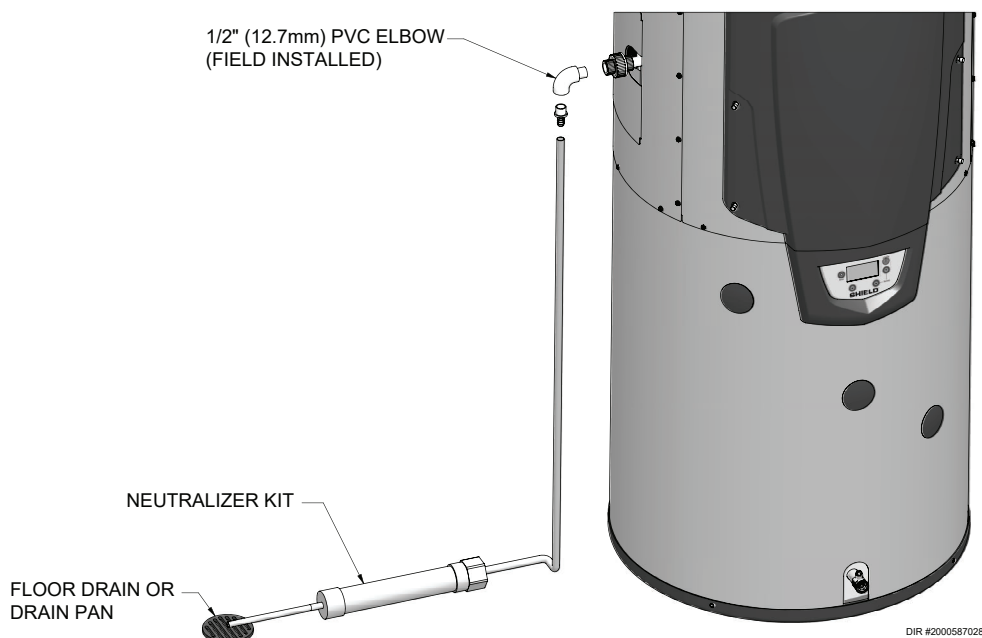

DIR #2000587028

## 9 Start-up

### Check/control water chemistry

#### NOTICE

Conduct water quality testing prior to installing the appliance. Various solutions are available to adjust water quality.

See the following table for properly operating the water heater with the appropriate water chemistry. Good water quality will help extend the life of the appliance by reducing the effects of scale buildup and corrosion.

**Table 9A Water Chemistry**

WATER CHEMISTRY		
Specification	Range	Requirement
Hardness	< 5 gpg	Follow recommendations detailed below (See Notice 3)
	5 to 12 gpg	No action required - standard pump
	> 12 gpg	Water softening system required (See Notice 4)
Dissolved Solids	< 350 ppm	Hardness level must be met
pH Level	6.5 to 8.5	Acceptable range
Chloride	< 150 ppm	Acceptable range

#### NOTICE

- Do not use the water heater to directly heat swimming pool or spa water.
- At initial fill and during water heater start-up and testing, check system thoroughly for any leaks. Repair all leaks before proceeding further.
- When water hardness levels are less than 5 gpg or 85.5 mg/l, the following is recommended:
  - Flush and clean existing water heating system prior to installation.
  - Inspect and, if necessary, replace the anodes in any existing tanks.
  - Install a Y-strainer on the inlet of each water heater as detailed in this section.
  - Limit the run time of the hot water recirculation loop.
  - Filter the hot water recirculation loop to a level of 10 microns. **CAUTION:** Check recirculation pump size to verify it is sized for filter addition and upsize if necessary.
- When water softener is required, a Template Assisted Crystallization system is recommended.

### Check for gas leaks

#### ⚠ WARNING

Before starting the water heater, and during initial operation, smell near the floor and around the water heater for gas odorant or any unusual odor. Remove the top access panel and smell the interior of the water heater enclosure. Do not proceed with startup if there is any indication of a gas leak. Use an approved leak detection solution. Repair any leaks at once.

#### ⚠ WARNING

DO NOT attempt to measure gas valve outlet pressure. The gas valve is factory-set for the correct outlet pressure. This setting is suitable for natural gas and propane (when configured for LP), requiring no field adjustment. Attempting to measure the gas valve outlet pressure could result in damage to the valve, causing potential severe personal injury, death, or substantial property damage.

#### ⚠ WARNING

Propane water heaters only – Your propane supplier mixes an odorant with the propane to make its presence detectable. In some instances, the odorant can fade, and the gas may no longer have an odor. Before startup (and periodically thereafter), have the propane supplier verify the correct odorant level in the gas.

### Inspect/fill condensate system

#### Inspect/check condensate lines and fittings

- Inspect the condensate drain line, condensate PVC fittings and condensate trap.

#### Fill condensate trap with water

- Remove the PVC cap retaining screw from the PVC cap (FIG. 9-1).
- Remove the 2 inch PVC cap with the switch located at the top of the trap (FIG. 9-1).
- Fill with fresh water until the water begins to pour out of the drain.
- Replace the cap. Press the cap onto the trap until the cap makes contact with the drain.
- Replace the retaining screw.

#### ⚠ WARNING

The condensate trap (FIG. 9-1) must be filled with water during all times of water heater operation to avoid flue gas emission from the condensate drain line. Failure to fill the trap could result in severe personal injury or death.

**Figure 9-1 Condensate Trap**

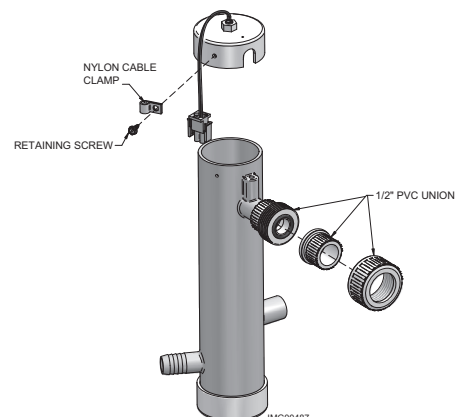

## 9 Start-up *(continued)*

### Final checks before starting the water heater

- ❑ Read this manual to familiarize yourself with electronic control module operation. Read pages 53 and 54 for proper steps to start the water heater.
- ❑ Verify the water heater is full of water by manually opening the relief valve on top of the unit to vent any remaining air out of the heat exchanger.
- ❑ Verify the system is full of water and all system components are correctly set for operation.
- ❑ Verify the preparation procedures of Section 9, pages 50 - 52 have been completed.
- ❑ Fill the vent condensate trap with water (removing the retaining screw in order to remove the 2 inch PVC cap with the switch located at the top of the trap). Replace the cap. Press the cap onto the trap until the cap makes contact with the drain. Replace the retaining screw.
- ❑ Verify electrical connections are correct and securely attached.
- ❑ Inspect vent piping and air piping for signs of deterioration from corrosion, physical damage or sagging. Verify air piping and vent piping are intact and correctly installed per this manual.

### Verify pump settings

Models 125 - 200 are equipped with a 3-speed circulator. Verify the correct pump speed setting using Table 9B (see below). Models 285 - 500 are equipped with a single speed circulator and cannot be adjusted.

**Table 9B Pump Settings**

Model	Pump Setting
125 - 150	HI
200	MED

### Start the water heater

1. Read and follow the Operating instructions in FIG.'s 9-2 and 9-3, pages 53 and 54.

### If water heater does not start correctly

1. Check for loose connections, blown fuse or service switch off.
2. Is external limit control (if used) open? Is water temperature above 200°F?
3. Is tank set point set below tank temperature?
4. Is gas turned on at meter and water heater?
5. Is incoming gas pressure less than 4 inches w.c.?

If none of the above corrects the problem, refer to the *Troubleshooting* section of this manual.

### Check system and water heater

#### ❑ Check water piping

1. Check system piping for leaks. If found, shut down the water heater and repair immediately.
2. Check Delta T. Ensure Delta T is less than 85°F, if not, reference *Section 12 - Troubleshooting*.
3. Vent any remaining air from the system using manual vents. Air in the system will interfere with circulation and cause hot water distribution problems and noise.

#### ❑ Check vent piping and air piping

1. Check for gastight seal at every connection, seam of air piping, and vent piping.

#### ⚠ WARNING

Venting system must be sealed gastight to prevent flue gas spillage and carbon monoxide emissions, which will result in severe personal injury or death.

#### ❑ Check gas piping

1. Check around the water heater for gas odor following the procedure on page 42 of this manual (*Connecting Gas Supply Piping*).

#### ⚠ WARNING

If you discover evidence of any gas leak, shut down the water heater at once. Find the leak source with a bubble test and repair immediately. Do not start the water heater again until corrected. Failure to comply could result in severe personal injury, death, or substantial property damage.

## 9 Start-up

### Check flame and combustion

1. Shut the water heater down by pressing the UP button for five (5) seconds.
2. Locate the flue sensor in the vent connection. Remove the flue sensor and grommet from the unit. **Note:** Combustion measurements will be made at this point.
3. Place the water heater in active position by pressing the UP button for five (5) seconds.
4. Place the water heater in Service Mode by pressing the ► and ▼ buttons simultaneously for 5 seconds.
5. Insert the probe from a combustion analyzer into the hole left by the removal of the flue temperature sensor.
6. Once the water heater has modulated up to full fire, measure the combustion. The values should be in the range listed in Table 9C. The CO levels should be less than 150 ppm for a properly installed unit.  
If the combustion is not within the specified range, reference the *Troubleshooting* section of this manual for possible causes and corrective actions.
7. Once the combustion analysis is complete, exit Service Mode.
8. Replace the flue sensor and grommet into the vent connection.
9. Place the Shield water heater back into normal operation.

**⚠ WARNING**

You must replace the flue sensor to prevent flue gas spillage into the room. Failure to comply could result in severe personal injury, death, or substantial property damage.

- ▲/▼ - Change the target fan speed in increments of 100 rpm.
- - Toggle between operating at high fire and low fire.
- ◀ - Exit Service Mode and return to the Home Screen.

**Table 9C Flue Products Chart**

Natural Gas				
Input Rate	Target		Range	
	CO <sub>2</sub>	O <sub>2</sub>	CO <sub>2</sub>	O <sub>2</sub>
High Fire	9.2%	4.5%	9.0% - 10.5%	2.1% - 4.8%
Low Fire	9.0%	4.8%	8.8% - 9.5%	3.9% - 5.2%
Propane				
Input Rate	Target		Range	
	CO <sub>2</sub>	O <sub>2</sub>	CO <sub>2</sub>	O <sub>2</sub>
High Fire	10.8%	4.5%	10.5% - 11.5%	3.5% - 5.0%
Low Fire	10.5%	5.0%	10.0% - 11.0%	4.2% - 5.8%

## 9 Start-up *(continued)*

Figure 9-2 Operating Instructions - Models 125 -- 285

### FOR YOUR SAFETY READ BEFORE OPERATING

**WARNING:** If you do not follow these instructions exactly, a fire or explosion may result causing property damage, personal injury, or loss of life.

- A. This appliance does not have a pilot. It is equipped with an ignition device which automatically lights the burner. Do not try to light the burner by hand.
- B. BEFORE OPERATING smell all around the appliance area for gas. Be sure to smell next to the floor because some gas is heavier than air and will settle on the floor.
- WHAT TO DO IF YOU SMELL GAS**
- Do not try to light any appliance.
- Do not touch any electric switch; do not use any phone in your building.
- Immediately call your gas supplier from a neighbor's phone. Follow the gas supplier's instructions.
- If you cannot reach your gas supplier, call the fire department.
- C. Use only your hand to move the gas control switch. Never use tools. If the switch will not move by hand, don't try to repair it, call a qualified service technician. Force or attempted repair may result in a fire or explosion.
- D. Do not use this appliance if any part has been under water. Immediately call a qualified service technician to inspect the appliance and to replace any part of the control system and any gas control which has been under water.

### OPERATING INSTRUCTIONS

- STOP!** Read the safety information above on this label.
- Set the thermostat to lowest setting.
- Turn off all electric power to the appliance.
- This appliance is equipped with an ignition device which automatically lights the burner. Do not try to light the burner by hand.
- Remove front door.
- Move switch to the "OFF" position.
- Wait five (5) minutes to clear out any gas. If you then smell gas, **STOP!** Follow "B" in the safety information above this label. If you don't smell gas, go to next step.
- Move the switch to the "ON" position.
- Install front door.
- Turn on all electric power to appliance.
- Set thermostat to desired setting.
- If the appliance will not operate, follow the instructions "To Turn Off Gas To Appliance" and call your service technician or gas supplier.

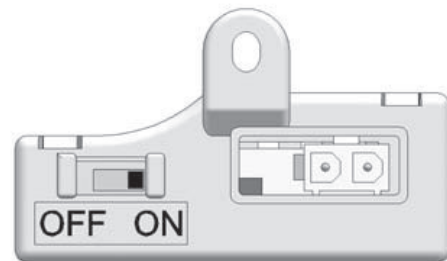

### TO TURN OFF GAS TO APPLIANCE

- Set the thermostat to lowest setting.
- Turn off all electric power to the appliance if service is to be performed.
- Remove front door.
- Move switch the "OFF" position.
- Install front door.

## 9 Start-up

Figure 9-3 Operating Instructions - Models 400 -- 500

### FOR YOUR SAFETY READ BEFORE OPERATING

**WARNING:** If you do not follow these instructions exactly, a fire or explosion may result causing property damage, personal injury, or loss of life.

- A. This appliance does not have a pilot. It is equipped with an ignition device which automatically lights the burner. Do not try to light the burner by hand.
  - B. BEFORE OPERATING smell all around the appliance area for gas. Be sure to smell next to the floor because some gas is heavier than air and will settle on the floor.
- WHAT TO DO IF YOU SMELL GAS**
- Do not try to light any appliance.
  - Do not touch any electric switch; do not use any phone in your building.
  - Immediately call your gas supplier from a neighbor's phone. Follow the gas supplier's instructions.
  - If you cannot reach your gas supplier, call the fire department.
- C. Use only your hand to turn the gas control knob. Never use tools. If the handle will not turn by hand, don't try to repair it, call a qualified service technician. Force or attempted repair may result in a fire or explosion.
  - D. Do not use this appliance if any part has been under water. Immediately call a qualified service technician to inspect the appliance and to replace any part of the control system and any gas control which has been under water.

### OPERATING INSTRUCTIONS

1. **STOP!** Read the safety information above on this label.
2. Set the thermostat to lowest setting.
3. Turn off all electric power to the appliance.
4. This appliance is equipped with an ignition device which automatically lights the burner. Do not try to light the burner by hand.
5. Remove top cover.
6. Turn gas shutoff valve counterclockwise to "OFF". Handle will be perpendicular to pipe. Do not force.
7. Wait five (5) minutes to clear out any gas. If you then smell gas, **STOP!** Follow "B" in the safety information above this label. If you don't smell gas, go to next step.
8. Turn gas shutoff valve clockwise to "ON". Handle will be parallel to pipe.
9. Install top cover.
10. Turn on all electric power to appliance.
11. Set thermostat to desired setting.
12. If the appliance will not operate, follow the instructions "To Turn Off Gas To Appliance" and call your service technician or gas supplier.

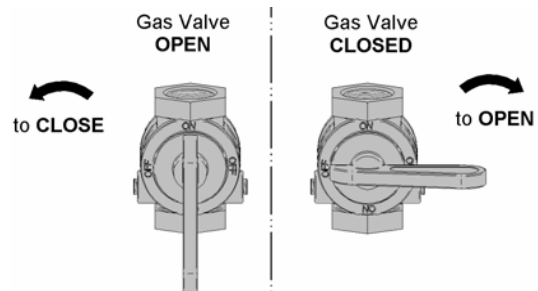

### TO TURN OFF GAS TO APPLIANCE

1. Set the thermostat to lowest setting.
2. Turn off all electric power to the appliance if service is to be performed.
3. Remove top cover.
4. Turn gas shut off valve counterclockwise to "OFF". Handle will be perpendicular to pipe. Do not force.
5. Install top cover.

LBL2284 REV -

# 9 Start-up *(continued)*

## SMART CONTROL™ Shield control module

Use the control panel (FIG. 9-4) to set temperatures, operating conditions, and monitor water heater operation.

Figure 9-4 Control Panel

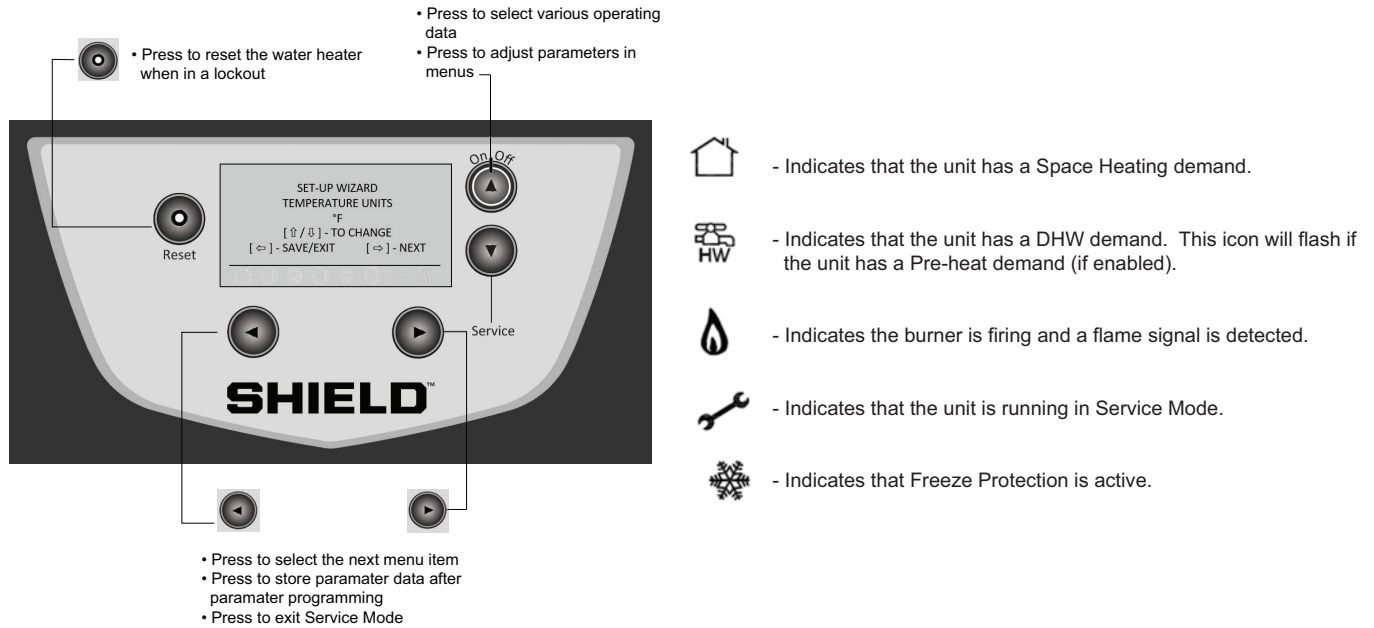

### Home screen

The Home Screen can be used to view the current operating information of the Shield water heater. The ▲ and ▼ buttons can be used to page through the screen sequence, displaying various operating statistics.

Figure 9-5 Screen Sequence

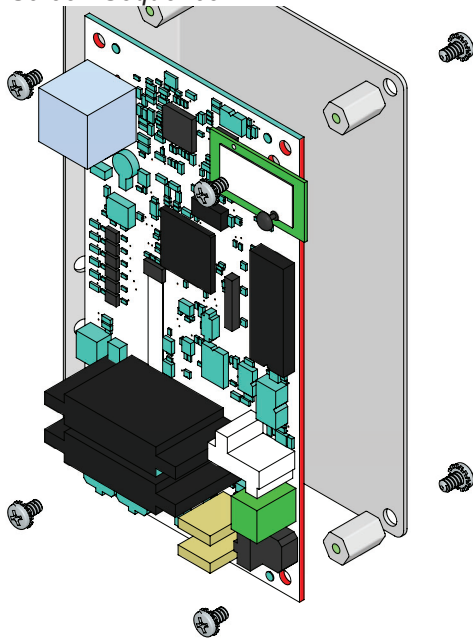

DIR 2000590078

## 9 Start-up

### Setup wizard

The Shield water heater control has a Setup Wizard feature that can be used to help with the initial start-up of the unit. This Setup Wizard will walk an installer through the most commonly required parameters.

The Setup Wizard is automatically accessed the first time the unit is powered up from the factory and will allow setting of certain parameters without the need to enter the installer password. Once the Setup Wizard is completed or canceled, it can only be accessed again by going through the Installer Menu.

**Figure 9-6** Installer Menu

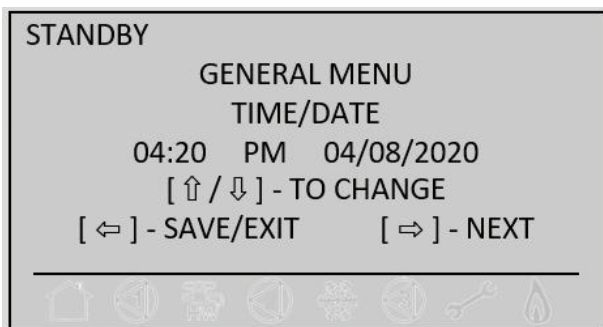

### Button functions in the setup wizard

- ▲/▼ - Change value of current parameter
- ▶ - Move to the next parameter or finish Setup Wizard on last parameter
- ◀ - Save changes and exit the Setup Wizard. This will bypass the remaining parameters in the Wizard.

To exit the menu without saving changes, you must cycle power to the unit before exiting the menu.

### Parameters in the setup wizard

- TEMPERATURE UNITS
  - Controls the units in which all temperature will be displayed.
  - Range: °F – °C
  - Default: °F
- TANK SETPOINT
  - Target water temperature for the tank thermostat. The electronic control senses the tank temperature and regulates water heater ignition and firing rate to achieve the target temperature.
  - Range: 60°F - 180°F
  - Default: 140°F

- TANK SETPOINT DIFFERENTIAL
  - Number of degrees below which the tank thermostat must fall for the electronic control to begin firing the heater to achieve the target temperature. See "Tank Setpoint Differential" for information about the Tank Setpoint Differential feature and its setup.
- TIME / DATE
  - The water heater control uses an internal clock for the night setback feature and for logging events. For these features to work properly, the clock must be set when the water heater is first installed or when the water heater has been powered off for more than 15 minutes. Note that the internal clock does not adjust for Daylight Savings Time and therefore, will require a manual adjustment.
- NIGHT SETBACK
  - This value represents the number of degrees by which the tank setpoint will be reduced while the Night Setback feature is active. See the Night Setback section of this manual for more information about the Night Setback feature and its setup.



# 10 Operating information

## General

### How the water heater operates

The Shield water heater combines an advanced stainless steel heat exchanger, electronic control module, and tank that allows fully condensing operation. The blower pulls in air and pushes flue products out of the heat exchanger and flue piping. The control module regulates blower speed to control the water heater firing rate. The gas valve senses the amount of air flowing into the water heater and allows only the right amount of gas to flow. An internal pump circulates the water between the tank and heater and mixes the incoming water to provide maximum efficiency.

### Temperature control

#### Modulation

The Shield water heater is capable of modulating its firing rate from a minimum of 20% to a maximum of 100%. The firing rate is dictated by the hot water draw and various other temperature limitations.

#### Night setback

The controller may be programmed to reduce the tank set point during a certain time each day. There are seven (7) start and seven (7) stop triggers.

#### Flame current support

To prevent nuisance shutdowns when the water heater is firing at minimum rates, the control will increase fan speed when the flame signal drops too low.

### Protection features

#### Outlet temperature, flue temperature, and temperature rise limiting

The heat exchanger outlet temperature is monitored by the heat exchanger outlet temperature sensor. When the heat exchanger outlet temperature exceeds 190°F, the unit will reduce the fan speed. If the heat exchanger outlet water temperature exceeds 198°F the control will shut the unit down until it cools off.

The control module monitors the flue temperature by a sensor located in the flue exhaust. If the flue temperature exceeds 215°F the control will reduce the maximum fan speed. If the flue temperature exceeds 225°F (107°C) the control will shut the unit down. The unit will restart automatically once the flue temperature drops 10°F (6°C) and the minimum off time has expired.

The control monitors the temperature difference between the heat exchanger inlet and the heat exchanger outlet sensors. If this difference exceeds 85°F the control will reduce the fan speed. If the temperature difference exceeds 95°F the control will shut the unit down. The unit will restart automatically once the temperature difference has dropped below 80°F and the minimum off time has expired.

### Freeze protection

DO NOT install the water heater in a room likely to freeze.

The following integral feature of the electronic control module provides some protection for the water heater.

- The electronic control module provides freeze-up protection as follows when the water heater water temperature drops below 45°F:
- Below 45°F, the internal pump operates constantly.
- Below 37°F, the burner turns on.
- The burner and pump will turn off if water heater water temperature rises above 45°F.

#### **CAUTION**

This feature of the electronic control module does not eliminate the possibility of freezing. The installation must still use recognized design, installation and maintenance practice to prevent freeze potential for the water heater.

### Runtime and alarm outputs

The water heater provides dry contacts for indicating when the water heater is running, and when it is unable to operate.

# 10 Operating information

## Water heater temperature regulation

### Operating temperature (target)

The electronic control module senses water temperature in the tank and regulates water heater ignition and firing rate to achieve a target temperature. The target temperature can be set between 60°F and 180°F.

### High limit operations

The Shield water heater is equipped with a fixed automatic reset high limit and an adjustable manual reset high limit. The automatic reset high limit has a set point of 200°F and the manual reset high limit has a maximum set point of 210°F.

When the outlet temperature exceeds 200°F, the automatic high limit action occurs. The water heater shuts down until the outlet water temperature cools below 190°F, and a 60 second timer has expired. If the outlet temperature continues to increase, the manual reset high limit action will occur at 210°F.

### Manual Reset High Limit (MRHL) test procedure

1. With the unit powered ON, note the HEX OUTLET temperature shown on the Main Screen.
2. Enter the Installer Menu by pressing the ► button from the Main Screen and then entering the installer password.
3. Navigate to the GENERAL submenu and select MRHL SETPOINT from the menu options.
4. Adjust the MRHL SETPOINT value to a temperature below the noted HEX OUTLET temperature from Step 1.
5. Press the ◀ button to save changes and return to the Installer Menu.
6. Press the ◀ button to return to the Main Screen.
7. The water heater will lock out and display "OUTLET MRHL".
8. Enter the Installer Menu by pressing the ► button from the Main Screen and then entering the installer password.
9. Navigate to the GENERAL submenu and select MRHL SETPOINT from the menu options.
10. Adjust the MRHL SETPOINT value to the desired value for normal operation.
11. Press the ◀ button to save changes and return to the Installer Menu.
12. Press the ◀ button to return to the Main Screen.
13. Press the RESET button to clear the Manual Reset High Limit lockout.

## Adjustable control parameters

### User adjustable parameters

The User Adjustable Parameters Menu can be accessed by pressing the ◀ button from the Main Home Screen. Once pressed, the tank temperature setpoint will be shown. Use the ▲/▼ to adjust the tank setpoint to the desired temperature. Once the desired tank setpoint is selected, press the ◀ again to save changes and exit the User Setpoint Menu.

**Table 10A** User Adjustable Parameters

Parameter	Description	Factory Default	Min	Max
TANK SETP	Tank / Hot Water Setpoint	125°F	60°F	180°F

# 10 Operating information *(continued)*

## Installer adjustable parameters

The Installer Menu can be accessed by pressing the ► button from the Main Screen and then entering the installer password.

**Figure 10-1** Installer Menu

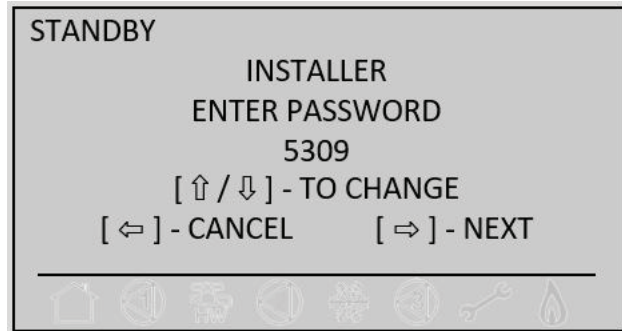

## Enter the installer password

To enter the installer password, use the ▲ and ▼ buttons to change the value of the first digit to 5, then press ► to move to the next digit. Repeat this process to fill in the remaining digits and enter the password 5-3-0-9. Once the final digit has been entered, press the ► button to access the Installer Menu. Entering the installer password will allow future access to the Installer Menu without requiring the password for up to an hour after the last button is pressed.

## Installer main menu

The Installer Menu is arranged in a menu/submenu structure to help with navigation to the desired settings. The Installer Main Menu gives a list of available submenus.

## Button functions in the installer main menu

- ▲/▼ - Move the cursor through the list of available submenus.
- - Access the currently selected submenu.
- ◀ - Save changes and exit the menu.

To exit the menu without saving changes, you must cycle power to the unit before exiting the menu.

## Button functions in the installer submenus

- ▲/ ▼ - Change value of current parameter.
- - Move to next parameter or return to main menu on last parameter in the submenu.
- ◀ - Return to Main Menu or save all changes and return to Home Screen on the last parameter in the submenu.

To exit the menu without saving changes, you must cycle power to the unit before exiting the menu.

## Parameters in the installer menu:

- GENERAL Submenu
  - TIME / DATE
  - TEMPERATURE UNITS
  - MAX SETPOINT
  - MANUAL RESET HI LIMIT
  - TANK SETPOINT DIFFERENTIAL
  - TANK SETPOINT OFFSET
  - PUMP DELAY
- NIGHT SETBACK Submenu
  - NIGHT SETBACK TEMP
  - NIGHT SETBACK Start and Stop Triggers
- BMS Menu
  - VOLTS AT MINIMUM
  - VOLTS AT MAXIMUM
  - OFFSET / DIFFERENTIAL VOLTS
  - RATE AT MINIMUM
  - RATE AT MAXIMUM
  - SETPOINT AT MAXIMUM
  - SETPOINT AT MINIMUM

## GENERAL Submenu

The General Submenu is located within the Installer Menu. Access the General Submenu by using the arrow keys to select GENERAL from the submenu list. Once accessed, the general menu parameters may be cycled and changed using the arrow keys. Table 10B below shows the parameters that may be changed using the general submenu along with their factory default, minimum, and maximum values. Once the desired changes have been made, press the ◀ button to save changes and return to the installer menu. Press the ◀ button once more to return to the main screen.

**Table 10B** General Submenu Parameter Settings

Parameter	Description	Factory Default	Min	Max
TIME / DATE	Time and Date used for Night Setback and Error Logging	--	--	--
TEMPERATURE UNITS	Temperature Display Units °F/ °C	°F	--	--
MAX SETPOINT	Maximum Tank Setpoint	180°F	60°F	180°F
MRHL SETPOINT	Manual Reset High Limit Setpoint	210°F	32°F	210°F
TANK SETP DIFF	Tank Setpoint Differential	8°F	--	--
TANK SETP OFFS	Tank Setpoint Offset	2°F	--	--
PUMP DELAY	Hot Water Pump Delay Time	30 sec.	0 sec.	40 min.

# 10 Operating information

## GENERAL submenu parameters

### TIME / DATE

The water heater control uses an internal clock for the night setback feature and for logging events. For these features to work properly, the clock must be set when the water heater is first installed or when the water heater has been powered off for more than 15 minutes. Note that the internal clock does not adjust for Daylight Savings Time and therefore, will require a manual adjustment.

### TEMPERATURE UNITS

This controls the units in which all temperatures will be displayed.

### MAX SETPOINT

The max setpoint should be set to the highest hot water set point that can be used for the specific domestic hot water system. This parameter is the upper limit of what the user can adjust the TANK SETP parameter to.

### MRHL SETPOINT

The MRHL SETPOINT sets the heat exchanger outlet temperature at which the Manual Reset High Limit action occurs. If the heat exchanger outlet temperature continues to increase after automatic reset high limit action, and beyond the MRHL SETPOINT, the Manual Reset High Limit action occurs. This will require a manual reset before operation can resume.

### TANK SETPOINT DIFF

The tank setpoint differential sets the number of degrees that the tank sensor must read below the tank setpoint for the water heater to begin firing.

### TANK SETPOINT OFFS

The tank setpoint offset sets the number of degrees that the tank sensor must read above the tank setpoint to satisfy the hot water demand.

### PUMP DELAY

The pump delay time sets the length of time after the hot water demand is satisfied for which the pump will run. This feature allows the pump to run for a length of time after the unit has fired in order to cool the water coils inside the heat exchanger.

## Night setback

The Night Setback submenu is located within the Installer Submenu. Access the Night Setback submenu by using the arrow keys to select NIGHT SETBACK from the submenu list.

This feature allows the user to lower the tank setpoint at specific times throughout the week. The night setback temperature value determines how much the tank setpoint is lowered during the time when the feature is active. The times at which the tank setpoint is lowered are controlled by seven (7) start and seven (7) stop triggers. Each trigger can be set to any time on any day. When the internal clock reaches a start trigger, night setback will become active. When the internal clock reaches a stop trigger, night setback will become inactive. When a start and stop trigger are programmed for the same day and time, the stop trigger will have priority, so night setback will remain inactive. (The default settings are all set to the same day and time.) Use the following procedure to set up the Night Setback feature:

Note: Any time the ◀ button is pressed during the Night Setback menu, the current settings will be saved, and the screen will return to the Installer Submenu list. To re-enter the Night Setback menu, simply select Night Setback from the Installer Submenu and use the ▶ button to advance through until the desired trigger is reached.

1. Access the Night Setback submenu within the installer menu and select the desired Night Setback temperature using the ▲ and ▼ buttons.
2. Press the ▶ button to advance to the next screen. This screen will display the default settings for the first Night Setback start trigger.
3. Use the ▲ and ▼ buttons to select the day of the week for the current trigger, then press the ▶ button to move to the time selection.
4. The time for the current trigger is displayed in a 12-hour format with the hour digits flashing. Use the ▲ and ▼ buttons to adjust the hours for the current trigger, then press the ▶ button.
5. The minutes digits will then start flashing. Use the ▲ and ▼ buttons to adjust the minutes for the current trigger, then press the ▶ button.
6. The AM/PM selection will then start flashing. Use the ▲ and ▼ buttons to select the appropriate AM/PM setting for the current trigger.
7. Repeat steps 2 through 6 to set day and time for all necessary start and stop triggers. Once all necessary triggers have been set, press the ◀ button to exit the Night Setback menu.

# 10 Operating information *(continued)*

## Low water cutoff protection

The electronic control module uses sensing of both heat exchanger supply and return temperatures. If the flow rate is too low or either temperature too high, the control module modulates and shuts the burner down. This ensures water heater shutdown in the event of low water or low flow conditions in the heat exchanger.

## To turn the heater ON/OFF

To turn the heater ON, press the UP button and hold it for five (5) seconds. To turn the heater OFF, press the UP button and hold again for five (5) seconds.

## Service mode



### WARNING

Entering Service Mode will immediately cause the water heater to fire. Failure to ensure that the unit is fully assembled and installed and in safe working condition; including having properly installed venting, all air purged from the heat exchanger, and with proper water supply and flow, can result in serious injury, death, significant property damage, or destruction of the heater.

The Shield water heater includes a Service Mode feature that can be used to force the unit to run at a particular firing rate. This feature can be used by qualified service technicians for adjusting combustion or troubleshooting the unit.

Service Mode can be accessed by holding ► and ▼ buttons simultaneously for 5 seconds.

## Building Management System (BMS)

### BMS

The Shield Water Heater can be controlled by a Building Management System (BMS) ONLY if equipped with an optional Modbus or BACnet control.

The water heater control can be configured by the installer to use a 0-10 VDC signal to control either tank setpoint or firing rate. When the BMS parameter is set to INACTIVE, the 0 - 10 VDC input will be ignored. When set to ACTIVE, the set point or modulation will be controlled by the voltage on the 0 - 10 VDC input (in the case of 0 - 10 VDC BMS control), or the 0 - 10 VDC input value received through ModBus or BACnet. The default value is INACTIVE.

### BMS type

When programmed for BMS control through ModBus/BACnet, the 0 - 10 VDC signal can be interpreted as either a modulation command or a set point. When the BMS Type parameter is set to POWER, the 0 - 10 VDC signal will control the modulation. When set to SETPOINT, the 0 - 10 VDC signal will control the hot water set point. The default setting is SETPOINT.

### Rate at minimum volts

When programmed for BMS control through ModBus/BACnet and the BMS Type is programmed as POWER, the modulation percentage represented by the Volts at Minimum parameter is set by the Rate at Minimum Volts parameter. The minimum value is 0% and the maximum is the Rate at Maximum Volts setting. The default value is model dependent.

### Rate at maximum volts

When programmed for BMS control through ModBus/BACnet and the BMS Type is programmed as POWER, the modulation percentage represented by the Volts at Maximum parameter is set by the Rate at Maximum Volts parameter. The minimum value is the Rate at Minimum Volts setting and the maximum is 100%. The default value is 100%.

### Setpoint at minimum volts

When programmed for BMS control through ModBus/BACnet and the BMS Type is programmed as SETPOINT, the set point represented by the Volts at Minimum parameter is set by the Set Point at Minimum Volts parameter. The minimum value is 60°F (0°C) and the maximum is the Set Point at Maximum Volts setting. The default value is 70°F (21°C).

# 10 Operating information

## Set Point at Maximum Volts

When programmed for BMS control through ModBus/BACnet and the BMS type is programmed as SETPOINT, the setpoint represented by the Volts at Maximum parameter is set by the Setpoint at Maximum Volts parameter. The minimum value is the Setpoint at Minimum Volts setting and the maximum is 180°F (88°C). The default value is 180°F (82°C).

## Volts at Minimum

When programmed for BMS control through ModBus/BACnet, the Volts at Minimum parameter should be set to the minimum voltage signal sent to the water heater control. The range of this parameter is 0.0V to the Volts at Maximum value. The default setting is 2.0V.

## Volts at Maximum

When programmed for BMS control through ModBus/BACnet, the Volts at Maximum parameter should be set to the maximum voltage signal sent to the water heater control. The range of this parameter is the Volts at Minimum value to 10.0V. The default value is 10.0V.

## Off Differential Volts

When programmed for BMS control through ModBus/BACnet and the BMS Thermostat Input is set to INACTIVE, the Off Differential Volts parameter determines how far below the On Volts setting the 0 - 10 VDC BMS input voltage must be in order to disable the water heater. The minimum value is 0.2V and the maximum is the On Volts setting. The default value is 1.0V.

## ModBus/BACnet

When BMS is set to ACTIVE (see BMS Active / Inactive) and the water heater is being controlled through BACnet or ModBus, set ModBus/BACnet parameter to ACTIVE. Otherwise, set the ModBus/BACnet parameter to INACTIVE. Note that the water heater can still be monitored by ModBus or BACnet with this parameter set to INACTIVE. The default value is INACTIVE.

# 11 Maintenance

## Maintenance and annual startup

Table 11A Service and Maintenance Schedules

<b>Service technician</b> (see the following pages for instructions)		<b>Owner maintenance</b>	
<b>ANNUAL START-UP</b>	<b>General:</b>		
	<ul style="list-style-type: none"> <li>• Address reported problems</li> <li>• Inspect interior; clean and vacuum if necessary;</li> <li>• Clean condensate trap and fill with fresh water</li> <li>• Check for leaks (water, gas, flue, condensate)</li> <li>• Verify flue and air lines in good condition and sealed tight</li> <li>• Check system water pressure/system piping/expansion tank</li> <li>• Check control settings</li> <li>• Check ignition and flame sense electrodes (sand off any deposits; clean and reposition)</li> <li>• Check wiring and connections</li> <li>• Perform combustion start-up checkout and performance verification per Section 9 in this manual</li> <li>• Flame inspection (stable, uniform)</li> <li>• Flame signal (at least 10 microamps at high fire)</li> <li>• Clean the heat exchanger if flue temperature is more than 54°F above return water temperature.</li> <li>• Check anode rods.</li> <li>• Check Delta T (Temperature Rise)</li> </ul>	<b>Daily</b>	<ul style="list-style-type: none"> <li>• Check water heater area</li> </ul>
	<p><b>If combustion or performance indicate need:</b></p> <ul style="list-style-type: none"> <li>• Clean heat exchanger</li> <li>• Remove and clean burner using compressed air only</li> <li>• Clean the blower wheel</li> </ul>	<b>Monthly</b>	<ul style="list-style-type: none"> <li>• Check vent piping</li> <li>• Check air piping</li> <li>• Check relief valve</li> <li>• Check condensate drain system</li> <li>• Check Delta T (Temperature Rise)</li> <li>• Remove debris from Y-strainer per manufacturer's instructions</li> <li>• Check building recirculation filter (if filter required)</li> <li>• Check for and clean any debris or obstruction from bird screens (if equipped)</li> </ul>
		<b>Every 6 months</b>	<ul style="list-style-type: none"> <li>• Check water heater piping (gas and water) for leaks</li> <li>• Operate relief valve</li> <li>• Check water chemistry</li> </ul>

# 11 Maintenance

**⚠ WARNING** Follow the service and maintenance procedures given throughout this manual and in component literature shipped with the water heater. Failure to perform the service and maintenance could result in damage to the water heater or system. Failure to follow the directions in this manual and component literature could result in severe personal injury, death, or substantial property damage.

**⚠ WARNING** The water heater should be inspected annually only by a qualified service technician. In addition, the maintenance and care of the water heater designated in Table 11A and explained on the following pages must be performed to assure maximum water heater efficiency and reliability. Failure to service and maintain the water heater and system could result in equipment failure.

**⚠ WARNING** Electrical shock hazard – Turn off power to the water heater before any service operation on the water heater except as noted otherwise in this instruction manual. Failure to turn off electrical power could result in electrical shock, causing severe personal injury or death.

## Address reported problems

1. Inspect any problems reported by the owner and correct before proceeding.

## Inspect water heater area

1. Verify that water heater area is free of any combustible materials, gasoline and other flammable vapors and liquids.
2. Verify that air intake area is free of any of the contaminants listed in Section 1 of this manual. If any of these are present in the water heater intake air vicinity, they must be removed. If they cannot be removed, reinstall the air and vent lines per this manual.

## Inspect water heater interior

1. Remove the pump access panel and inspect the interior of the water heater.
2. Vacuum any sediment from inside the water heater and components. Remove any obstructions.

## Clean condensate trap

1. Inspect the condensate drain line, condensate PVC fittings, and condensate trap.
2. Remove the PVC cap retaining screw from the PVC cap (FIG. 11-1).
3. Remove the 2 inch PVC cap with the switch located at the top of the trap (FIG. 11-1).
4. Remove any sediment in the trap.
5. Fill with fresh water until the water begins to pour out of the drain.
6. Replace the cap. Press the cap onto the trap until the cap makes contact with the drain.
7. Replace the retaining screw.

**Figure 11-1 Condensate Trap**

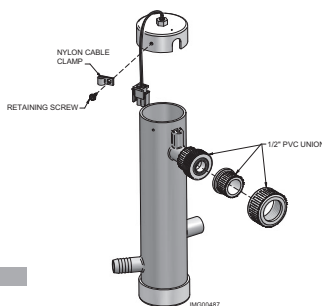

**⚠ WARNING** The condensate trap must be filled with water during all times of water heater operation to avoid flue gas emission from the condensate drain line. Failure to fill the trap could result in severe personal injury or death.

## Check all piping for leaks

**⚠ WARNING** Eliminate all system or water heater leaks. Leaking water may cause severe property damage.

1. Inspect all water and gas piping and verify to be leak free.
2. Look for signs of leaking lines and correct any problems found.
3. Check gas line using the procedure found in Section 6 - Gas Connections.

## Flue vent system and air piping

1. Visually inspect the entire flue gas venting system and air piping for blockage, deterioration or leakage. Repair any joints that show signs of leakage. Verify that air inlet pipe is connected and properly sealed.
2. Verify that water heater vent discharge and air intake are clean and free of obstructions.
3. Verify that bird screens are clean and free of debris or obstruction.

**⚠ WARNING** Failure to inspect for the above conditions and have them repaired can result in severe personal injury or death.

## Check water system

1. Verify all system components are correctly installed and operational.
2. Check the cold fill pressure for the system. Verify it is correct (must be a minimum of 12 PSI).
3. Watch the system pressure as the water heater heats up (during testing) to ensure pressure does not rise too high. Excessive pressure rise indicates expansion tank sizing or performance problem.
4. Inspect automatic air vents and air separators. Remove air vent caps and briefly push valve to flush vent. Replace caps. Make sure vents do not leak. Replace any leaking vents.



# 11 Maintenance *(continued)*

## Check expansion tank

1. Expansion tanks provide space for water to move in and out as the water expands due to temperature increase or contracts as the water cools. Tanks must be approved for potable water systems. See Section 5 - System Piping for suggested best location of expansion tanks.

## Check water heater relief valve

1. Inspect the relief valve and lift the lever to verify flow. Before operating any relief valve, ensure that it is piped with its discharge in a safe area to avoid severe scald potential. Read Section 5 - System Piping before proceeding further.

### **⚠ WARNING**

Safety relief valves should be re-inspected **AT LEAST ONCE EVERY THREE YEARS**, by a licensed plumbing contractor or authorized inspection agency, to ensure that the product has not been affected by corrosive water conditions and to ensure that the valve and discharge line have not been altered or tampered with illegally. Certain naturally occurring conditions may corrode the valve or its components over time, rendering the valve inoperative. Such conditions are not detectable unless the valve and its components are physically removed and inspected. This inspection must only be conducted by a plumbing contractor or authorized inspection agency – not by the owner. Failure to re-inspect the water heater relief valve as directed could result in unsafe pressure buildup, which can result in severe personal injury, death, or substantial property damage.

### **⚠ WARNING**

Following installation, the valve lever must be operated **AT LEAST ONCE A YEAR** to ensure that waterways are clear. Certain naturally occurring mineral deposits may adhere to the valve, rendering it inoperative. When manually operating the lever, water will discharge and precautions must be taken to avoid contact with hot water and to avoid water damage. Before operating lever, check to see that a discharge line is connected to this valve directing the flow of hot water from the valve to a proper place of disposal. Otherwise severe personal injury may result. If no water flows, valve is inoperative. Shut down the water heater until a new relief valve has been installed.

2. After following the warning directions, if the relief valve weeps or will not seat properly, replace the relief valve. Ensure that the reason for relief valve weeping is the valve and not over-pressurization of the system due to expansion tank waterlogging or undersizing.

## Inspect ignition and flame sense electrodes

1. Remove the ignition and flame sense electrodes from the water heater heat exchanger access cover.
2. Remove any deposits accumulated on the ignition/flame sense electrode using sandpaper. If the electrodes cannot be cleaned satisfactorily, replace with new ones.
3. Replace ignition/flame sense electrode, making sure gasket is in good condition and correctly positioned.

## Check ignition ground wiring

1. Inspect water heater ground wire from the heat exchanger access cover to ground terminal strip.
2. Verify all wiring is in good condition and securely attached.
3. Check ground continuity of wiring using continuity meter.
4. Replace ground wires if ground continuity is not satisfactory.

## Check all water heater wiring

1. Inspect all water heater wiring, making sure wires are in good condition and securely attached.

## Check control settings

1. Set the control module display to Parameter Mode and check all settings. Adjust settings if necessary. See Section 10 of this manual for adjustment procedures.
2. Check settings of external limit controls (if any) and adjust if necessary.

## Perform start-up and checks

1. Start water heater and perform checks and tests specified in Section 9 - Start-up.
2. Verify cold fill pressure is correct and that operating pressure does not go too high.

# 11 Maintenance

## Check burner flame

1. Inspect flame through observation window.
2. If the flame is unsatisfactory at either high fire or low fire, turn off water heater and allow water heater to cool down. Remove the burner and clean it thoroughly using a vacuum cleaner or compressed air. Do not use compressed air to clean burner if performed inside a building.
3. Remove the burner, reference FIG. 11-2 below.
4. When replacing the burner, ensure gasket is in good condition and positioned correctly (FIG. 11-2).

**Figure 11-2 Burner Assembly**

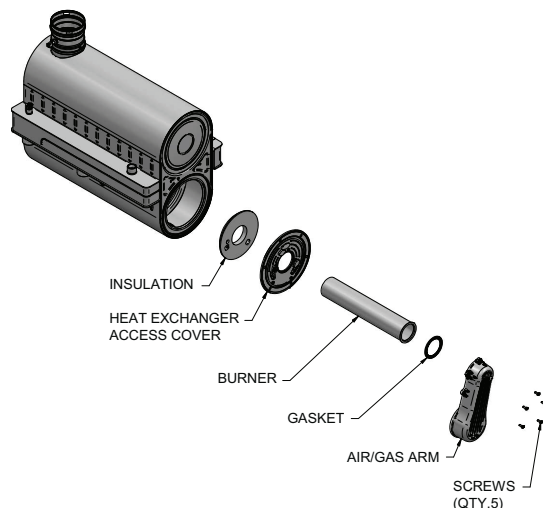

## Check flame signal

1. At high fire the flame signal shown on the display should be at least 10 microamps.
2. A lower flame signal may indicate a fouled or damaged flame sense electrode. If cleaning the flame sense electrode does not improve, ground wiring is in good condition, and ground continuity is satisfactory, replace the flame sense electrode.
3. See Section 12 - Troubleshooting for other procedures to deal with low flame signal.

## Review with owner

1. Emphasize the need to perform the maintenance schedule specified in this manual.
2. Remind the owner of the need to call a licensed contractor should the water heater or system exhibit any unusual behavior.

## Handling ceramic fiber materials

### REMOVAL OF COMBUSTION CHAMBER LINING

#### ⚠ WARNING

The combustion chamber insulation in this appliance contains ceramic fiber material. Ceramic fibers can be converted

to cristobalite in very high temperature applications. The International Agency for Research on Cancer (IARC) has concluded, "Crystalline silica inhaled in the form of quartz or cristobalite from occupational sources is carcinogenic to humans (Group 1)." Normal operating temperatures in this appliance are below the level to convert ceramic fibers to cristobalite. Abnormal operating conditions would have to be created to convert the ceramic fibers in this appliance to cristobalite.

The ceramic fiber material used in this appliance is an irritant; when handling or replacing the ceramic materials it is advisable that the installer follow these safety guidelines.

#### ■ Avoid breathing dust and contact with skin and eyes.

- Use NIOSH certified dust respirator (N95). This type of respirator is based on the OSHA requirements for cristobalite at the time this document was written. Other types of respirators may be needed depending on the job site conditions. Current NIOSH recommendations can be found on the NIOSH website at <http://www.cdc.gov/niosh/homepage.html>. NIOSH approved respirators, manufacturers, and phone numbers are also listed on this website.

- Wear long-sleeved, loose fitting clothing, gloves, and eye protection.

#### ■ Apply enough water to the combustion chamber lining to prevent airborne dust.

#### ■ Remove the combustion chamber lining from the appliance and place it in a plastic bag for disposal.

#### ■ Wash potentially contaminated clothes separately from other clothing. Rinse clothes washer thoroughly.

### NIOSH stated First Aid.

- Eye: Irrigate immediately.
- Breathing: Fresh air.

## Cleaning heat exchanger

For recommended materials; including brush, appropriate extension(s), refractory cover, and detailed instructions see Table 11B - Heat Exchanger Cleaning Kits on page 67.

1. Shut down water heater:
  - Follow the "To Turn Off Gas to Appliance" instructions for the water heater in Section 9 - Startup.
  - Do not drain the water heater unless it will be exposed to freezing temperatures. If using freeze prevention fluid in system, do not drain.
2. Allow time for the water heater to cool to room temperature if it has been firing.

# 11 Maintenance *(continued)*

- Remove the nuts securing the heat exchanger access cover to the heat exchanger and set aside.
- Remove the heat exchanger access cover, burner, and gas/air arm assembly.

**WARNING** The water heater contains ceramic fiber materials. Use care when handling these materials per instructions in this manual. Failure to comply could result in severe personal injury.

- Remove the condensate hose from the heat exchanger end. Connect a field supplied 3/4" diameter hose to a drain pan. Using field supplied means, cover the refractory in the back of the combustion chamber of the heat exchanger.
- Use a vacuum cleaner to remove any accumulation on the water heater heating surfaces. Do not use any solvent.
- Brush the heat exchanger while dry using a nylon bristle brush. **Caution:** DO NOT use a metal brush. Re-vacuum the heat exchanger.
- Finish cleaning using a clean cloth dampened with warm water. Rinse out debris with a low pressure water supply.
- Allow the heat exchanger to thoroughly dry.
- Remove the field supplied rear refractory cover from the back of the combustion chamber of the heat exchanger and reassemble.
- Close isolation valves on piping to isolate water heater from system. Attach a hose to the water heater drain and flush water heater thoroughly with clean water by using purging valves to allow water to flow through the water make-up line to the water heater.
- Perform start-up and check-out procedures in the Check Flame and Combustion - Section 9 - Startup on page 52 of this manual.
- Replace the access cover and restore water heater to operation.

**Table 11B Heat Exchanger Cleaning Kits**

Model	Kit Number	Part Number	Component Description
125 -- 200 285 -- 400	100157627	100140243	Rear Refractory Cover
		100162565*	Nylon 4" Wheel Brush*
		100162566	3mm Allen Wrench
		100162568	1/4" x 24" Drill Extension
500	100157628	100140243	Rear Refractory Cover
		100162565*	Nylon 4" Wheel Brush*
		100162567	1/4" x 12" Drill Extension
		100162568	1/4" x 24" Drill Extension

## CAUTION

\* Do NOT use a metal brush. Only use the kit provided brush or an equivalent replacement nylon brush.

**Figure 11-3 Rope Gasket - Heat Exchanger Door**

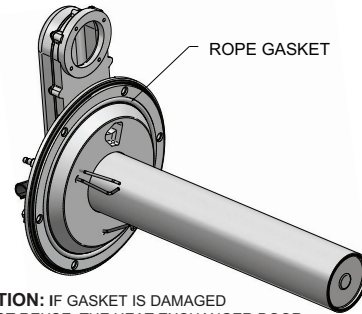

**CAUTION:** IF GASKET IS DAMAGED DO NOT REUSE, THE HEAT EXCHANGER DOOR MUST BE REPLACED.

## NOTICE

Rope gasket is intended for sealing combustion (FIG. 11-3). If damaged DO NOT reuse, the heat exchanger door must be replaced. Consult factory for replacement heat exchanger door (kit 100173749).

## Oiled bearing circulators

- The circulator shipped with the Shield water heater is water-lubricated. No oiling is required.
- Check other circulators in the system. Oil any circulators requiring oil, following circulator manufacturer's instructions. Over-oiling will damage the circulator.

## Magnesium anode rod inspection

Glass lined storage tanks have a magnesium anode(s) (FIG. 11-4) to provide cathodical protection of the lining and minimize corrosion. Aggressive water conditions in some areas of the country may accelerate the deterioration of the anode(s). The anode(s) should be periodically removed and inspected to determine if replacement is necessary.

The heater must be valved off from the system and fully drained to remove an anode for inspection. Anodes are supplied in threaded fittings on the side of the tank. Adequate service clearance is required to allow removal of an anode. The anode(s) should be replaced when more than six inches of the core wire is exposed at either end of the rod.

**Figure 11-4 Anode Location**

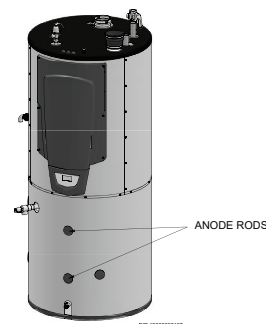

## NOTICE

Anode rods showing excessive decomposition may indicate electrolysis. An earth ground should be attached to the vessel to divert stray current and prevent tank damage.

# 12 Troubleshooting

**⚠ WARNING** Label all wires prior to disconnection when servicing controls. Wiring errors can cause improper and dangerous operation. Always disconnect power to the water heater before servicing. Failure to comply could result in severe personal injury, death, or substantial property damage.

**⚠ WARNING** Never jumper (bypass) any device except for momentary testing as outlined in the Troubleshooting chart. Severe personal injury, death, or substantial property damage can result.

## Before troubleshooting:

- Have the following items:
  - Voltmeter that can check 120 VAC, 24 VAC, and 12 VDC.
  - Continuity checker.
  - Contact thermometer.
- Check for 120 VAC (minimum 102 VAC to maximum 132 VAC) to water heater.
- Make sure the tank is calling for heat.
- Make sure all external limit controls are installed and operating.

## Check the following:

- Wire connectors to control module and connection board are securely plugged in.
- Gas pressures:
  - Maximum: 14 inches w.c. (natural and LP) with no flow (lockup) or with water heater on
  - Minimum: 4 inches w.c. (natural), 8 inches w.c. (LP) with gas flowing (verify during water heater startup)

## Check control module fuses

**NOTICE** ALWAYS check control module fuses before replacing control module or any major components (blower, etc.). If one of these fuses is blown, it can prevent the control module or other components from operating.

- Turn OFF power to the water heater at the external disconnect switch.
- Remove front access cover.
- Remove the control module cover.
- Inspect fuses F2, F3, F4, and F5, see FIG. 12-1 below.

**Figure 12-1** Control Module Fuses

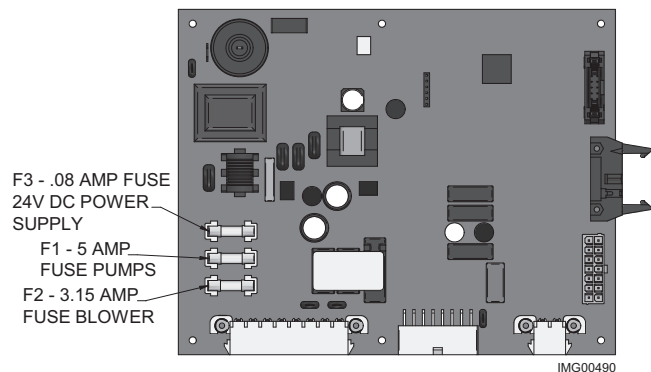

- The water heater is shipped with three (3) spare fuses in a plastic bag attached to the control module cover.
- If necessary, replace open fuse (F3 is 1.25 amps, F2 and F4 are 3.15 amps, and F5 is 5 amps).

**Note:** Fuses F2 - F5 are all slow blow fuses.

**⚠ WARNING** Do not jumper fuse or replace with any fuse except as specified. Failure to comply could result in severe personal injury, death, or substantial property damage.

- Install control module cover and front access cover after fuse inspection.
- Restore power to the water heater at the external disconnect switch and verify water heater operation (Section 9 - Start-up) after completing water heater service.

# 12 Troubleshooting *(continued)*

**Table 12A Troubleshooting Chart - No Display**

<b>FAULT</b>	<b>CAUSE</b>	<b>CORRECTIVE ACTION</b>
<b>No Display</b>	- No 120 VAC supplied to unit.	<ul style="list-style-type: none"> <li>• Check external line switch, fuse, or breaker.</li> <li>• Check wiring harness connection between display board and main control board. Connect harness at both points.</li> </ul>
	- Bad display board.	<ul style="list-style-type: none"> <li>• Replace board.</li> </ul>
	- Bad main control board.	<ul style="list-style-type: none"> <li>• Replace the main control board.</li> </ul>
	- Blown fuse.	<ul style="list-style-type: none"> <li>• Replace fuse F3 on the main control board, see page 68 of this manual.</li> </ul>
<b>No Burner Operation</b>	- Tank temperature set point satisfied.	<ul style="list-style-type: none"> <li>• Review temperature setting.</li> </ul>
	- Unit locked out on fault.	<ul style="list-style-type: none"> <li>• Consult display for specific fault. Refer to fault descriptions on page 72 of this manual for corrective actions.</li> </ul>
<b>Unit Does Not Modulate Above 50%</b>	- Flue sensor open.	<ul style="list-style-type: none"> <li>• Verify that the flue sensor is located in the flue outlet.</li> </ul>
		<ul style="list-style-type: none"> <li>• Check wiring connections at the flue sensor.</li> </ul>
		<ul style="list-style-type: none"> <li>• Check the resistance of the flue sensor and compare to Table 12D on page 70 of this manual.</li> </ul>

# 12 Troubleshooting

## Checking temperature sensors

The water heater temperature sensors (inlet water, outlet water, tank water, and flue) are all resistance type devices. The following tables show the correct values for the sensors at various temperatures. Use an ohmmeter to read the resistance of the sensor at a known temperature. If the resistance of the sensor does not closely match its corresponding table, replace the sensor.

**Table 12B - Inlet Tank Sensor Resistance vs. Temperature**

Temperature °F	Resistance $\Omega$	Temperature °F	Resistance $\Omega$
50	18,780	158	1,990
68	12,263	176	1,458
86	8,194	194	1,084
104	5,592	212	817
122	3,893	--	--
140	2,760	--	--

**Table 12C - Outlet Water Sensor Resistance vs. Temperature**

S1a (Wire Color - R/BK and Y)				S1b (Wire Color - G and Y)			
Temperature	Resistance	Temperature	Resistance	Temperature	Resistance	Temperature	Resistance
50	19,553	158	2,004	50	40,030	158	3,478
68	12,690	176	1,464	68	25,030	176	2,492
86	8,406	194	1,084	86	16,090	194	1,816
104	5,715	212	816	104	10,610	212	1,344
122	3,958			122	7,166		
140	2,786			140	4,943		

**Table 12D - Flue Temperature Sensor Resistance vs. Temperature**

S3a (Wire Color - W/B and Y)				S3b (Wire Color - PR and Y)			
Temperature	Resistance	Temperature	Resistance	Temperature	Resistance	Temperature	Resistance
50	40,030	158	3,478	50	258,500	158	16,870
68	25,030	176	2,492	68	125,500	176	12,000
86	16,090	194	1,816	86	80,220	194	8,674
104	10,610	212	1,344	104	52,590	212	6,369
122	7,166			122	35,270		
140	4,943			140	24,160		

# 12 Troubleshooting *(continued)*

**Table 12E Troubleshooting Chart - Noisy System**

FAULT	CAUSE	CORRECTIVE ACTION
<b>Noisy Operation</b>	- Supply gas problem. Natural gas pressures should be between 4 inches w.c. and 14 inches w.c. LP gas pressures should be between 8 inches w.c. and 14 inches w.c.	• Refer to Section 6 - Gas Connections for detailed information concerning the gas supply.
	- Gas/air mixture problem.	• Refer to the Gas Valve Adjustment Procedure on page 79 of this manual for the proper gas valve setting. Verify that the vent/air intake lengths do not exceed the maximum listed in the General Venting section.
	- Dirty/damaged burner.	• Refer to page 66 in this manual for the burner removal and inspection procedure. Clean or replace the burner as necessary.
	- Low water flow through the heat exchanger.	• Verify pump operation.
	- Air in the piping system.	• Properly purge all air from the piping system.
<b>No Pump Operation</b>	- Blown fuse.	• Replace fuse F5 on the control board, see page 68 of this manual.
	- Faulty pump.	• Replace pump.
	- Faulty pump relay.	• Replace pump relay.
	- Internal fault on control board.	• Replace main control board.
<b>Relief Valve Opening</b>	- System pressure exceeds relief valve setting.	• Lower the system pressure below the 150 PSI rating of the supplied relief valve.

# 12 Troubleshooting

**Table 12F** Troubleshooting Chart - Fault Messages Displayed on Water Heater Interface

FAULT	DESCRIPTION	CORRECTIVE ACTION
<b>MEMORY ERROR</b>	The control module has detected parameter settings that are corrupted.	<ul style="list-style-type: none"> <li>• Replace control module.</li> </ul>
<b>FAN SPEED</b> (will require a manual reset once the condition has been corrected. Press the RESET button on the display to reset.)	The actual fan RPM is outside of the tolerance of the fan speed RPM target.	<ul style="list-style-type: none"> <li>• Vent/air intake lengths exceed the maximum allowed lengths. Refer to Section 2 - General Venting for proper lengths.</li> <li>• Check for obstruction or blockage in the vent/air intake pipes or at terminations.</li> <li>• Check the wiring connections at the fan and at the main control board.</li> <li>• Replace the fan.</li> <li>• Replace the main control board.</li> </ul>
	Blown fuse.	<ul style="list-style-type: none"> <li>• Replace fuse F2 on the control board, see page 68 of this manual.</li> </ul>
<b>Flow Switch/ LWCO</b> (will require a manual reset once condition has been corrected. Press the RESET button on the SMART SYSTEM display to reset.)	The low water cutoff (LWCO) is not making.	<ul style="list-style-type: none"> <li>• Check water heater pump operation on a call for heat.</li> <li>• Check for closed valves or obstructions in the water heater piping.</li> <li>• Verify system is full of water and all air has been purged from the system.</li> <li>• Check for a loose or misplaced jumper if flow switch is not installed.</li> <li>• Replace LWCO.</li> </ul>
	Blown fuse.	<ul style="list-style-type: none"> <li>• Replace fuse F3 on the control board, see page 68 of this manual.</li> </ul>
<b>FLAME SEQUENCE</b> (will require a manual reset once the condition has been corrected. Press the RESET button on the display to reset.)	The flame detector circuit is seeing a flame signal when the gas valve is OFF.	<ul style="list-style-type: none"> <li>• Verify flame is not present. If present, turn off gas supply and replace gas valve.</li> <li>• Check supply voltage for proper polarity.</li> <li>• Check external wiring for voltage feedback.</li> <li>• Check the flame rod and make sure it is clean.</li> <li>• Check the internal wiring for bad connections.</li> <li>• Replace main control board.</li> </ul>



# 12 Troubleshooting *(continued)*

**Table 12F** (continued from previous page) *Troubleshooting Chart - Fault Messages Displayed on Water Heater Interface*

FAULT	DESCRIPTION	CORRECTIVE ACTION
<p><b>OUTLET ARHL</b></p>	<p>The outlet water temperature has exceeded the setting of the automatic reset high limit.</p>	<ul style="list-style-type: none"> <li>• Adjust the set point of the auto reset limit to a higher setting up to a maximum of 200°F. Reference Section 10 - Operating Information for adjusting procedures.</li> <li>• Verify that the system is full of water and that all air has been properly purged from the system.</li> <li>• Verify that the water heater is piped properly into the heating system. Refer to Section 5 - System Piping for the proper piping methods for the Shield water heater.</li> <li>• Check 120 vac to water heater pump motor on a call for heat. If voltage is not present, check wiring back to the main control board.</li> <li>• Replace the main control board if necessary.</li> <li>• If 120 vac is present on a call for heat and the water heater pump is not operating, replace the pump.</li> <li>• If operating on something other than an outlet sensor, check temperature setting of the main control board.</li> <li>• If the optional manual reset high limit has tripped, check setting of the device.</li> <li>• Check resistance of water sensors and compare to Table 12C on page 70 of this manual. Replace sensor if necessary.</li> <li>• Check operation of diverter valve motor. Replace if necessary.</li> </ul>
<p><b>AIR PRESSURE SWITCH</b> (will require a manual reset once the condition has been corrected. Press the RESET button on the display to reset.)</p>	<p>Air pressure switch contacts are open or heat exchanger thermal switch is open.</p>	<ul style="list-style-type: none"> <li>• Check the wiring connections to switch. Wires should be connected to the common and normally closed terminals.</li> <li>• Air intake lengths exceed the maximum allowed lengths. Refer to Section 2 - General Venting for proper lengths.</li> <li>• Check for obstruction or blockage in the air intake pipes or at terminations.</li> <li>• Check reference hoses connected to the air pressure switch for blockage or obstruction.</li> <li>• Inspect the burner. Reference page 66 of this manual for removal and cleaning procedures. Replace if necessary.</li> <li>• Inspect the heat exchanger. Reference page 66 of this manual for removal and cleaning procedures.</li> <li>• Faulty air pressure switch. Replace switch.</li> <li>• Check the wiring connections to the fuse on the heat exchanger.</li> <li>• Check continuity across the thermal fuse. If open, replace heat exchanger.</li> </ul>
<p><b>BLOCKED DRAIN SW</b> (will require a manual reset once the condition has been corrected. Press the RESET button on the display to reset.)</p>	<p>The blocked drain switch has detected excessive condensate build-up inside the unit.</p>	<ul style="list-style-type: none"> <li>• Check the condensate tube from unit to floor drain for proper installation and obstructions.</li> <li>• Inspect condensate trap for blockage. Clean if necessary.</li> <li>• Check for loose wiring connection at wire harness plug.</li> <li>• Bad blocked drain switch. Replace switch.</li> </ul>

# 12 Troubleshooting

**Table 12F** (continued from previous page) *Troubleshooting Chart - Fault Messages Displayed on Water Heater Interface*

FAULT	DESCRIPTION	CORRECTIVE ACTION
<p><b>AUX LIMIT FAULT</b></p>	<p>Aux limit device open.</p>	<ul style="list-style-type: none"> <li>• Check wiring to aux limit device.</li> <li>• Check aux limit device.</li> </ul>
<p><b>FLAME FAIL: RUNNING</b> (will require a manual reset once the condition has been corrected. Press the RESET button on the display to reset.)</p>	<p>The unit has lost flame signal four (4) times during a call for heat.</p>	<ul style="list-style-type: none"> <li>• Inspect spark electrode and associated wiring for damage and connection. Reference page 65 of this manual for removal and cleaning procedures. Replace if necessary.</li> <li>• Check for proper electrical grounding of the unit.</li> <li>• Check incoming supply gas pressure. Natural gas pressures should be between 4 - 14 inches w.c. and LP gas pressures should be between 8 - 14 inches w.c. Refer to Section 6 - Gas Connections for detailed information concerning the gas supply.</li> <li>• Verify that the plastic hose from the gas valve to the air inlet is connected and is not damaged.</li> <li>• Verify that the vent/air intake pipes are correctly installed and that there are no obstructions.</li> <li>• Check for 24 vac to the gas valve at the 2-pin connection on the side of the main control board during the ignition attempt. If no voltage is present, replace the main control board.</li> <li>• If 24 vac is present at the main control board, check the wiring between the main control board and the gas valve. Replace the wiring if necessary. Do not disconnect the wiring from the gas valve and attempt to measure voltage at that point. The main control board can detect if the gas valve is not connected and will display the Gas Valve or Gas Valve Fail fault.</li> </ul>
<p><b>FLAME FAIL: IGNITION</b> (will require a manual reset once the condition has been corrected. Press the RESET button on the display to reset.)</p>	<p>The unit has failed to prove main burner ignition after several attempts.</p>	<ul style="list-style-type: none"> <li>• If 24 vac is present, check the outlet of the valve to ensure the valve is flowing gas. With a manometer connected to the outlet tap of the gas valve, when the unit is in the prepurge period, there should be a negative pressure present. When the valve is energized a change in pressure should occur. If the pressure change does not occur, the gas valve is not opening. Replace the gas valve.</li> <li>• Inspect flame sensor and associated wiring. Reference page 65 of this manual for removal and cleaning procedures. Replace if necessary.</li> <li>• Inspect and clean the heat exchanger as necessary. Reference page 66 of this manual for cleaning procedures.</li> <li>• Inspect the burner. Reference page 66 of this manual for removal and cleaning procedures. Replace if necessary.</li> <li>• Replace the main control board.</li> </ul>

# 12 Troubleshooting *(continued)*

**Table 12F** (continued from previous page) Troubleshooting Chart - Fault Messages Displayed on Water Heater Interface

FAULT	DESCRIPTION	CORRECTIVE ACTION
<b>FLUE TEMP LIMIT</b>	The stack temperature has exceeded the Flue Temp Limit set parameters.	<ul style="list-style-type: none"> <li>Inspect the heat exchanger. Reference page 66 of this manual for the procedure on how to clean the flue side of the heat exchanger.</li> </ul>
<b>FLUE TEMP HIGH</b>	The stack temperature has exceeded the set parameters for the water heater.	<ul style="list-style-type: none"> <li>Inspect the flue sensor and associated wiring. Measure the resistance of the flue sensor and compare to Table 12D on page 70 of this manual. Replace the sensor if necessary.</li> <li>Verify that the vent/air intake pipes are properly installed and that there are no obstructions.</li> <li>Replace the main control board.</li> </ul>
<b>OUTLET MRHL</b> (will require a manual reset once the condition has been corrected. Press the RESET button on the display to reset.)	The outlet water temperature has exceeded the setting of the manual reset high limit.	<ul style="list-style-type: none"> <li>Verify that the system is full of water and that all air has been properly purged from the system.</li> <li>Verify that the water heater is piped properly into the heating system. Refer to Section 5 - System Piping for the proper piping methods for the Shield water heater.</li> </ul>
<b>OUTLET TEMP HIGH</b>	Outlet water temperature has exceeded the maximum outlet water temperature.	<ul style="list-style-type: none"> <li>Check 120 vac to water heater pump motor on a call for heat. If voltage is not present, check wiring back to the main control board.</li> <li>Replace the main control board if necessary.</li> <li>If 120 vac is present on a call for heat and the water heater pump is not operating, replace the pump.</li> <li>If operating on something other than an outlet sensor, check temperature setting of the main control board.</li> <li>Check resistance of water sensors and compare to Table 12C on page 70 of this manual. Replace sensor if necessary.</li> <li>Check operation of diverter valve motor. Replace if necessary.</li> </ul>
<b>OUTLET TEMP DIFF</b> (will require a manual reset once the condition has been corrected. Press the RESET button on the display to reset.)	The temperature difference between the two (2) outlet sensors is too high.	<ul style="list-style-type: none"> <li>Check wiring to sensor. Make sure wiring is connected and not damaged. Reconnect / repair wiring if necessary.</li> <li>Measure the resistance of the sensor and compare to the resistance in Table 12C on page 70 of this manual. Replace sensor if necessary.</li> <li>Replace control module.</li> </ul>
<b>FLUE SENSOR FAULT</b> (will require a manual reset once the condition has been corrected. Press the RESET button on the display to reset.)	One or both of the flue sensors is open or shorted.	<ul style="list-style-type: none"> <li>Inspect the flue sensor and associated wiring. Measure the resistance of the flue sensor and compare to Table 12D on page 70 of this manual. Replace the sensor if necessary.</li> <li>Replace the main control board.</li> </ul>

# 12 Troubleshooting

**Table 12F** (continued from previous page) *Troubleshooting Chart - Fault Messages Displayed on Water Heater Interface*

FAULT	DESCRIPTION	CORRECTIVE ACTION
<b>OUTLET SENSOR FAULT</b> (will require a manual reset once the condition has been corrected. Press the RESET button on the display to reset.)	One or both of the outlet sensors has opened or shorted.	<ul style="list-style-type: none"> <li>• Check the sensor and its associated wiring. Repair or replace the sensor or wiring if damaged.</li> <li>• Measure the resistances of the sensors and compare the resistances to the tables on page 70. Replace if necessary.</li> </ul>
<b>INLET SENSOR FAULT</b> (will require a manual reset once the condition has been corrected. Press the RESET button on the display to reset.)	The inlet sensor is open.	<ul style="list-style-type: none"> <li>• Check the sensor and its associated wiring. Repair or replace the sensor or wiring if damaged.</li> </ul>
<b>SET POINT MET</b>	The temperature has reached the set point + 10°F.	<ul style="list-style-type: none"> <li>• None</li> </ul>
<b>ANTI-CYCLING</b>	The main control board has received a call for heat too quickly after the previous call for heat has ended.	<ul style="list-style-type: none"> <li>• The control board will release the call for heat after 60 seconds.</li> <li>• The control board will release the call for heat if the outlet temperature drops 10°F.</li> </ul>
<b>DELTA T HIGH</b>	The temperature rise across the heat exchanger has exceeded the set parameters for the water heater.	<ul style="list-style-type: none"> <li>• Verify that the system is full of water and that all air has been properly purged from the system.</li> <li>• Verify that the water heater is piped properly into the heating system. Refer to Section 5 - System Piping for the proper piping methods for the Shield water heater.</li> <li>• Check for 120 vac to the water heater pump motor on a call for heat. If voltage is not present, check the wiring back to the main control board. Replace the main control board if necessary.</li> </ul>
	The fan speed is being limited due to the temperature rise across the heat exchanger exceeding 80°F.	<ul style="list-style-type: none"> <li>• If 120 vac is present on a call for heat and the water heater pump is not operating, replace the pump.</li> <li>• Verify that the water heater pump is set to the proper speed or that the pump is the proper size. Reference Section 5 - System Piping for water heater pump specifications.</li> </ul>

# 12 Troubleshooting *(continued)*

**Table 12F** (continued from previous page) Troubleshooting Chart - Fault Messages Displayed on Water Heater Interface

FAULT	DESCRIPTION	CORRECTIVE ACTION
<b>LOW VOLTAGE</b>	120 vac input to the main control board has dropped below 80 vac.	<ul style="list-style-type: none"> <li>• Check 120 vac supply to the transformer.</li> <li>• Check wiring connections at the low voltage terminal strip.</li> <li>• Check the wire size/length to remote devices.</li> <li>• Replace the transformer.</li> <li>• Check 24V.</li> </ul>
<b>NO FLUE TEMP CHANGE</b>	The flue temperature did not change after the burner started firing.	<ul style="list-style-type: none"> <li>• Verify that the flue sensor is installed.</li> <li>• Check the sensor and its associated wiring. Repair or replace the sensor or wiring if damaged.</li> </ul>
<b>SENSOR FAULT</b>	DHW sensor is not connected.	<ul style="list-style-type: none"> <li>• Check the DHW sensor and its associated wiring. Repair or replace as needed.</li> </ul>
<b>LOCKOUT INLET SENSOR FAULT</b>	The inlet sensor has been disconnected.	<ul style="list-style-type: none"> <li>• Check the sensors and their associated wiring. Repair or replace the sensor or wiring if damaged.</li> <li>• Measure the resistance of the sensors and compare the resistance to the tables on page 70 of this manual.</li> <li>• Replace the sensor if necessary.</li> </ul>
	The inlet sensor has been shorted.	<ul style="list-style-type: none"> <li>• Check the sensors and their associated wiring. Repair or replace the sensor or wiring if damaged.</li> <li>• Measure the resistance of the sensors and compare the resistance to the tables on page 70 of this manual.</li> <li>• Replace the sensor if necessary.</li> </ul>
<b>OUTDOOR SENSOR MISSING</b>	The outdoor sensor has opened or shorted.	<ul style="list-style-type: none"> <li>• Check the sensors and their associated wiring. Repair or replace the sensor or wiring if damaged.</li> <li>• Measure the resistance of the sensors and compare the resistance to the tables on page 70 of this manual.</li> <li>• Replace the sensor if necessary.</li> </ul>

# 12 Troubleshooting

## Combustion Analysis Procedure

1. Shut the water heater down by pressing the UP button for five (5) seconds.
2. Locate the flue sensor in the vent connection. Remove the flue sensor and grommet from the unit. **Note:** Combustion measurements will be made at this point.
3. Place the water heater in active position by pressing the UP button for five (5) seconds.
4. Press ENTER plus the UP button for five (5) seconds to enter Service Mode.
5. Insert the probe from a combustion analyzer into the hole left by the removal of the flue temperature sensor.
6. Once the water heater has modulated up to full fire, measure the combustion. The values should be in the range listed in Table 12G. The CO levels should be less than 150 ppm for a properly installed unit.
7. Once the combustion analysis is complete, exit Service Mode.
8. Replace the flue sensor and grommet into the vent connection.
9. Place the Shield water heater back into normal operation.

### ⚠ WARNING

You must replace the flue sensor to prevent flue gas spillage into the room. Failure to comply could result in severe personal injury, death, or substantial property damage.

If the combustion is not within the specified range, reference the *Troubleshooting* section of this manual for possible causes and corrective actions.

**Table 12G Flue Products**

Natural Gas				
Input Rate	Target		Range	
	CO <sub>2</sub>	O <sub>2</sub>	CO <sub>2</sub>	O <sub>2</sub>
High Fire	9.2%	4.5%	9.0% - 10.5%	2.1% - 4.8%
Low Fire	9.0%	4.8%	8.8% - 9.5%	3.9% - 5.2%
Propane				
Input Rate	Target		Range	
	CO <sub>2</sub>	O <sub>2</sub>	CO <sub>2</sub>	O <sub>2</sub>
High Fire	10.8%	4.5%	10.5% - 11.5%	3.5% - 5.0%
Low Fire	10.5%	5.0%	10.0% - 11.0%	4.2% - 5.8%

**Table 12H Troubleshooting Chart - Combustion Levels**

POSSIBLE CAUSE	CORRECTIVE ACTION
Vent/Air Intake Length or Obstruction	<ul style="list-style-type: none"> <li>• Refer to Section 2 - General Venting for the proper venting and air intake methods for the Shield water heater.</li> <li>• Check for obstructions at the vent/air intake terminals.</li> </ul>
Gas Supply Pressure	<ul style="list-style-type: none"> <li>• Refer to Section 6 - Gas Connections for the proper gas supply for the Shield water heater.</li> </ul>
Dirty/Damaged Burner	<ul style="list-style-type: none"> <li>• Refer to page 66 of this manual for burner removal and cleaning procedures.</li> <li>• Replace burner if necessary.</li> </ul>
Gas Valve Adjustment	<ul style="list-style-type: none"> <li>• Refer to page 79 of this manual for the gas valve adjustment procedure.</li> </ul>

# 12 Troubleshooting *(continued)*

## Gas valve adjustment procedure

If adjustment of the gas valve is deemed necessary, use the following procedures: (**Note:** The procedures below are model specific.)

### Models 125 -- 285

Locate the throttle adjustment screw on the side of the venturi valve (FIG. 12-2). Using a screwdriver, turn the screw a 1/4 turn **clockwise** to decrease CO<sub>2</sub> levels or a 1/4 turn **counterclockwise** to increase CO<sub>2</sub> levels. After performing one adjustment on the valve, follow the Combustion Analysis Procedure on page 78 of this manual to measure the combustion.

If combustion is still not within the specified range, repeat the procedure. This procedure **SHOULD NOT** be performed more than four (4) times. If after four (4) adjustments and the combustion is still not within the specified range, revisit the possible causes in Table 12H on page 78 or replace the gas valve.

**Figure 12-2 Gas Valve Adjustment: Models 125-- 285**

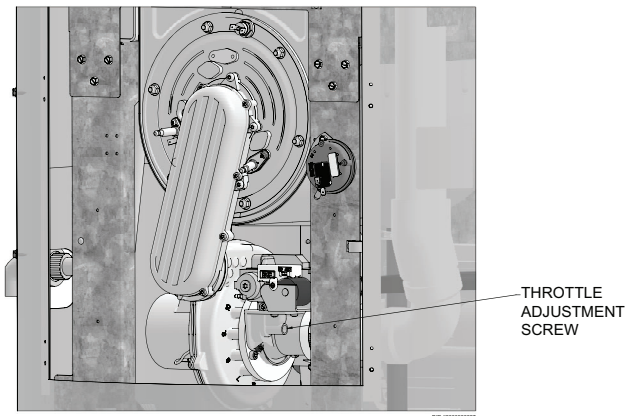

### Models 400 -- 500

Locate the throttle adjustment screw on the front of the gas valve, see FIG. 12-3. Using a screwdriver, turn the screw 1/2 turn **CLOCKWISE** to increase CO<sub>2</sub> levels or 1/2 turn **COUNTERCLOCKWISE** to decrease CO<sub>2</sub> levels. After one adjustment on the valve, follow the Combustion Analysis Procedure on page 78 of this manual to measure the combustion.

If combustion is still not within the specified range, repeat this procedure. This procedure **SHALL NOT** be performed more than four (4) times. If after four (4) adjustments and the combustion is still not within the specified range, revisit the possible causes in Table 12H on page 78 or replace the gas valve.

**Figure 12-3 Gas Valve Adjustment: Models 400 -- 500**

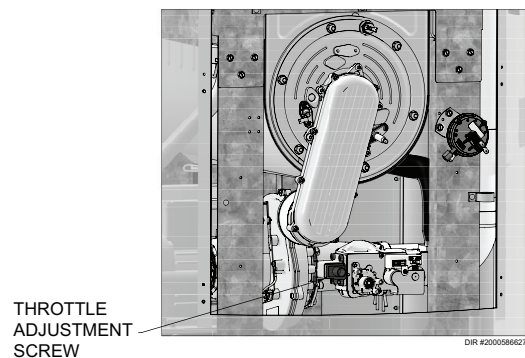

# 13 Diagrams

Figure 13-1 Ladder Diagram

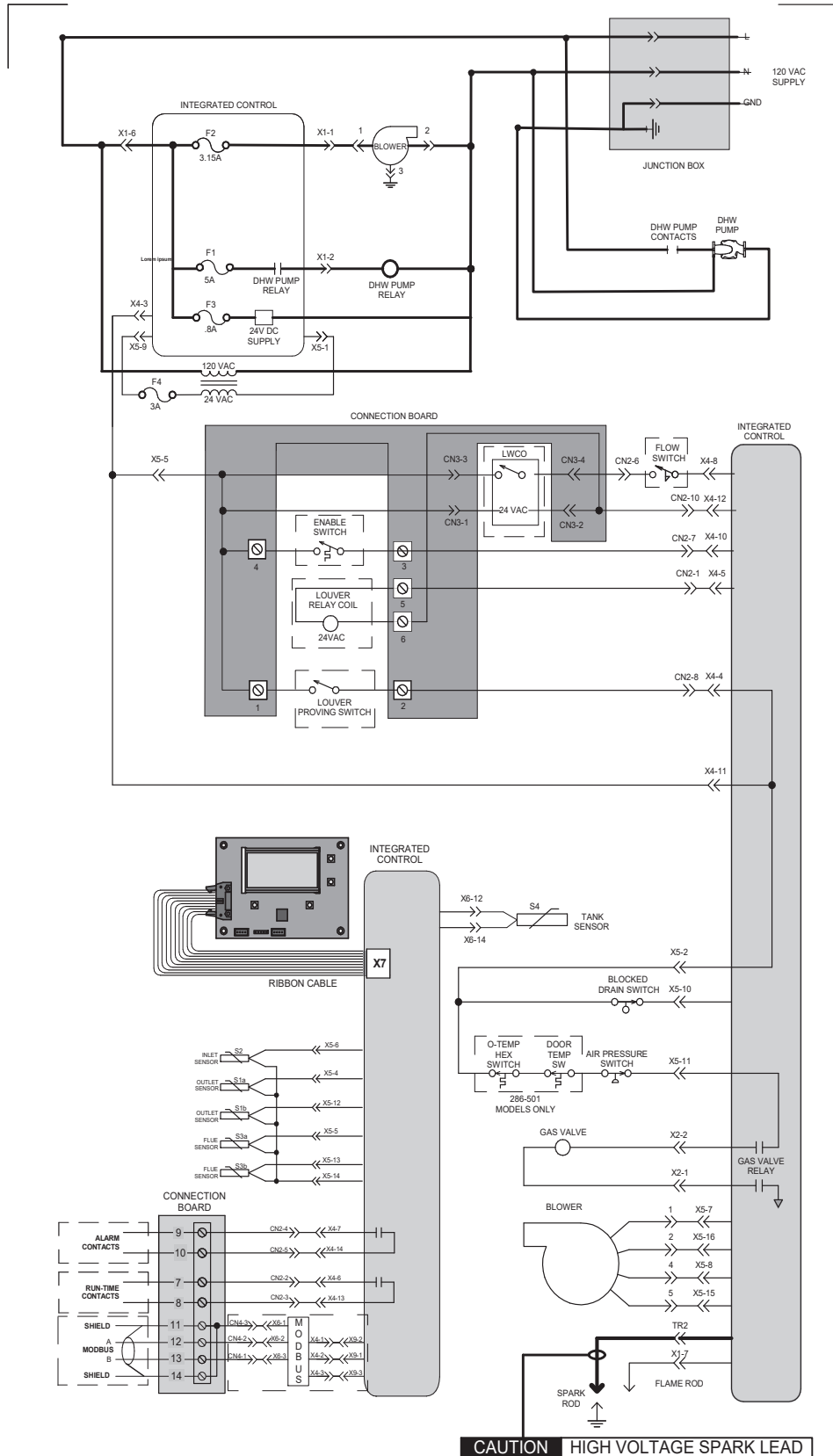

**NOTES:**  
 1. Where possible, switches are shown without utilities (gas, water or electricity) connected to the unit. As such, actual switch states may vary from those shown on diagrams depending upon whether utilities are connected or a fault condition is present.  
 2. See wiring diagram for additional notes.



# 13 Diagrams *(continued)*

Figure 13-2 Wiring Diagram

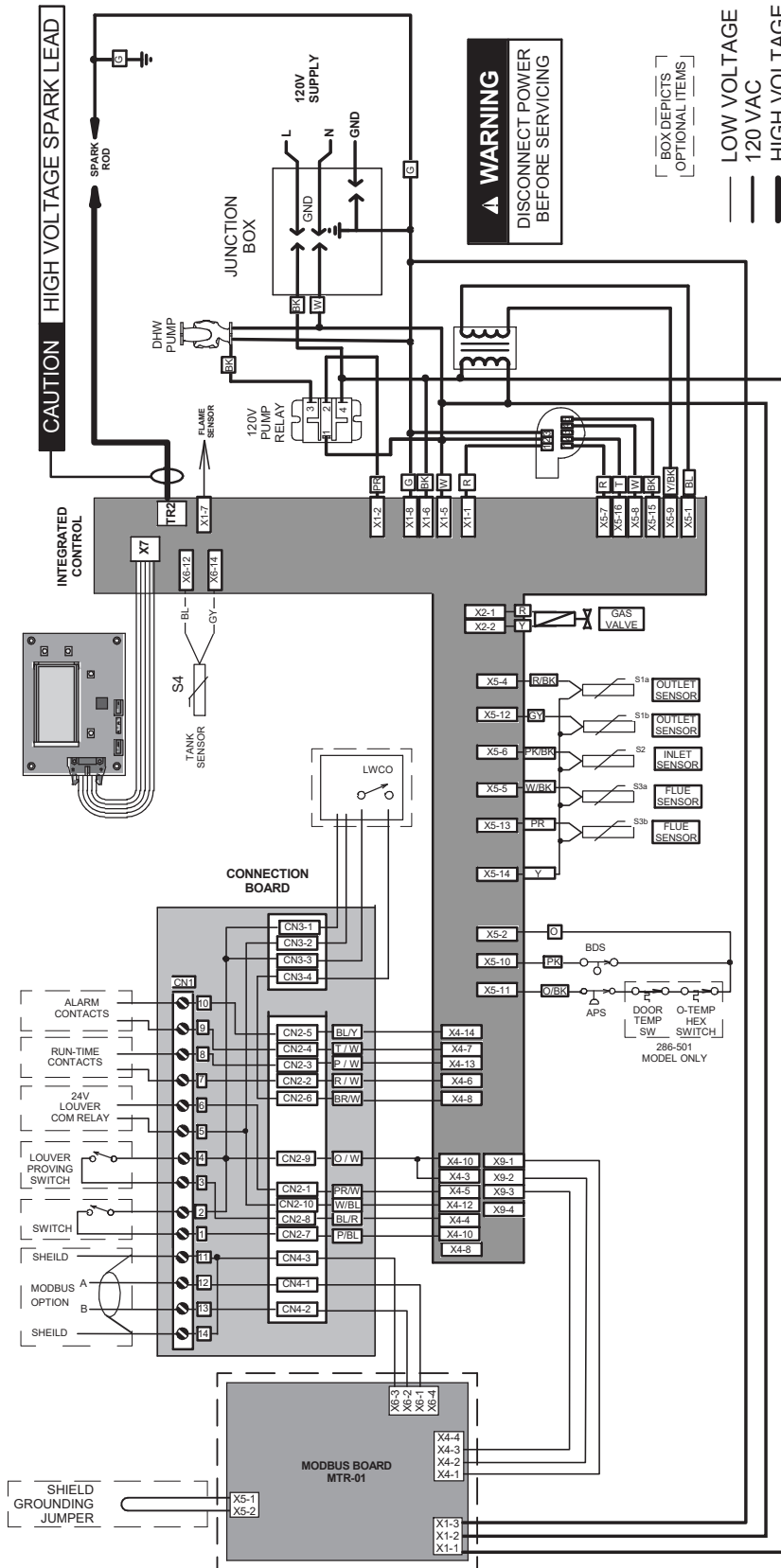

100328092 REV C

- Notes:
1. All wiring must be installed in accordance with local, state, provincial and national code requirements per either N.E.C. in USA or C.S.A. in Canada.
  2. If any original equipment wire as supplied with the appliance must be replaced, it must be replaced with wire having same wire gauge (AWG) and rated for a minimum of 105°C. Exceptions: Replacement high voltage spark lead and ribbon cables must be purchased from the factory. Use of a non-approved spark lead or ribbon cables can lead to operational problems which could result in non-repairable damage to the integrated controller or other components.
  3. Actual connector block locations may vary from those shown on diagrams. Refer to actual components for proper connector block locations when using diagrams to troubleshoot unit.

# Notes

---

# Notes

---

**Revision Notes:** *Revision A (PCP #3000038210 / CN #500026403) initial release.*

*Revision B (PCP #3000040019 / CN #500028121) reflects an update to Table 2E.*

*Revision C (PCP #3000041012 / CN #500028988) reflects updates made to the System Piping (page 37) and Start-up sections (page 51), Table 10B (page 59), Table 12D (page 70), high altitude changes (page 7), along with the Centrotherm updates on pages 21 and 30.*

*Revision D (PCP #3000043757 / CN #500031386) reflects an update to the throttle adjustment procedure for the 400-500 models.*

*Revision E (PCP #3000044312 / CN #500032090) reflects a correction to a few component callout numbers in the "How It Works" section. Updates were also made to the wiring and ladder diagrams and the blocked drain switch fault in the Troubleshooting section. Also included are some minor updates to the piping diagrams.*

*Revision F (PCP #3000045219 / CN #500032730) reflects an update to FIG. 3-3A - 3-3B and Tables 3B - 3C.*

*Revision G (PCP #3000045704 / CN #500033253) reflects an update to the image on the front cover.*