



PF92950 Emergency Backup Sump Pump

Product Features

- 12 Volt DC pump
- Vertical float switch
- Electric control panel with indicator lights
- Thermoplastic battery box
- 87 decibel alarm with mute
- Reverse polarity protection
- Low battery alarm
- Battery charge percentage indicator
- Manual test button
- Pump status indicator
- Maximum flow rate 45 gpm
- 1-1/2" NPT discharge size
- Handles 3/8" solids
- 5 amp AC charger
- Full flow check valve
- Battery sold separately



PF92950

Motor Performance

- 12 Volt DC

Performance Chart					
Lift	0'	5'	10'	15'	20'
GPM	45	42	36	25	12
GPH	2700	2520	2160	1500	720

Product Specifications

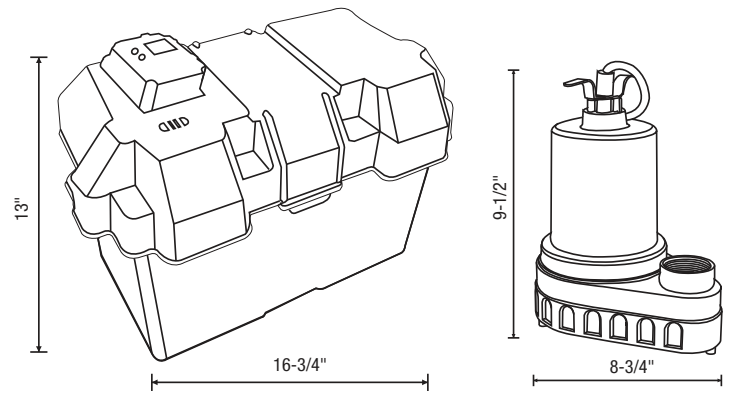

* All measurements are nominal. Please verify before actual installation.

Warranty and Codes

This product comes complete with installation, operating, care and maintenance instructions. This PROFLO sump pump carries a 3 year warranty when installed in residential applications. See owners manual for warranty details.

This PROFLO sump pump carries a 3 year limited warranty. In an effort to continually improve our products, we will make design changes from time to time. We reserve the right to ship newly designed product to fill any order unless it is agreed in writing to do otherwise.

