



PF99295 Sewage Basin Poly Extension

Product Features

- For use with PF93015 & PF93020 pre-assembled simplex sewage pump kits (sold separately)
- 18" X 12"
- Polyethylene construction
- Max Temperature Rating: 120°F (49°C)
- Material: Polyethylene



PF99295

Product Specifications

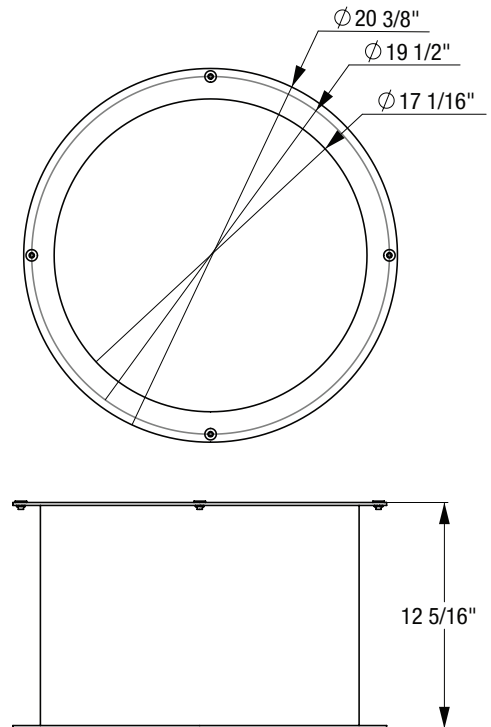

* All measurements are nominal. Please verify before actual installation.

Warranty and Codes

This PROFLO accessory carries a 1 year warranty when installed in residential applications.

In an effort to continually improve our products, we will make design changes from time to time. We reserve the right to ship newly designed product to fill any order unless it is agreed in writing to do otherwise.