

CODE	ND1	ND2	D	L1	L2	L3	L	H
27NRDE3225	1" => 32 mm	3/4" => 25 mm	1.73	1.56	1.56	2.76	3.33	2.54

NIRON



ITEM: **NRDE**

DESC: ELECTROFUSION REDUCER
SDR 11



DRAWING No:
NI10201

SHEET OF	REV.
1 3	-7

www.nupiamericas.com - info@nupiamericas.com

All dimensions have to be considered in inches with 5% tolerance if not otherwise mentioned excluding values as per standard ASTM F2389

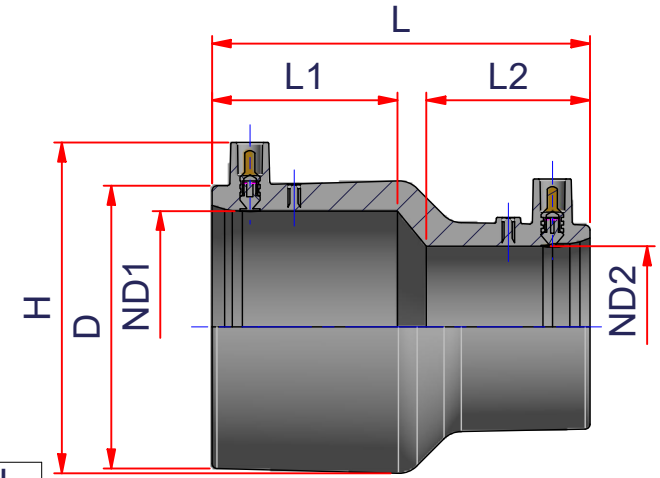

CODE	ND1	ND2	D	L1	L2	L3	L	H
27NRDE4032	1" 1/4=> 40 mm	1" => 32 mm	2.17	1.85	1.65	-	3.74	2.91
27NRDE5032	1" 1/2 => 50 mm	1" => 32 mm	2.52	1.95	1.63	-	3.94	3.35
27NRDE5040	1" 1/2 => 50 mm	1" 1/4=> 40 mm	2.52	1.95	1.87	-	4.06	3.35
27NRDE6332	2" => 63 mm	1" => 32 mm	3.21	2.19	1.65	-	4.65	3.90
27NRDE6340	2" => 63 mm	1" 1/4=> 40 mm	3.21	2.17	1.77	-	4.65	3.90
27NRDE6350	2" => 63 mm	1" 1/2 => 50 mm	3.21	2.19	1.97	-	4.65	3.90
27NRDE7563	2" 1/2 => 75 mm	2" => 63 mm	3.82	2.36	2.24	-	4.92	4.49
27NRDE9063	3" => 90 mm	2" => 63 mm	4.53	2.68	2.44	-	5.91	5.16
27NRDE9075	3" => 90 mm	2" 1/2 => 75 mm	4.57	2.89	2.56	-	6.00	5.16
27NRDE1163	4" => 110 mm	2" => 63 mm	5.31	2.85	2.48	-	6.30	5.93
27NRDE1190	4" => 110 mm	3" => 90 mm	5.31	2.87	2.70	-	6.22	5.93
27NRDE1263	5" => 125 mm	2" => 63 mm	5.91	2.99	2.56	-	6.40	6.57
27NRDE1290	5" => 125 mm	3" => 90 mm	5.91	3.15	2.76	-	6.30	6.57
27NRDE1211	5" => 125 mm	4" => 110 mm	6.14	2.76	2.81	-	6.34	6.57
27NRDE1690	6" => 160 mm	3" => 90 mm	7.56	3.19	2.83	-	6.97	8.15
27NRDE1611	6" => 160 mm	4" => 110 mm	7.56	3.19	3.03	-	7.36	8.15
27NRDE1612	6" => 160 mm	5" => 125 mm	7.36	3.30	2.91	-	7.03	7.91

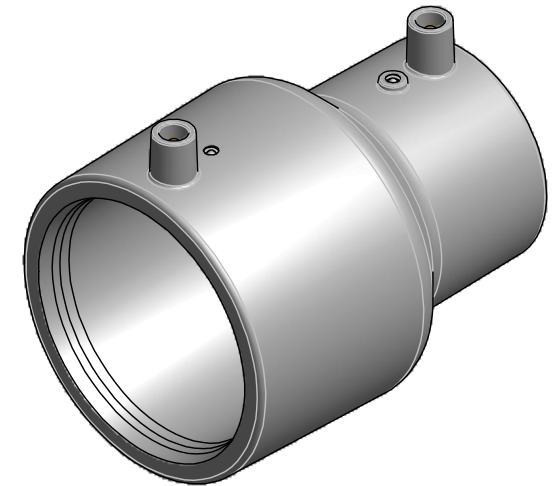

NIRON



ITEM: **NRDE**

DESC: ELECTROFUSION REDUCER
SDR 11



DRAWING No:
NI10201

SHEET OF	REV.
2 3	-7

www.nupiamericas.com - info@nupiamericas.com

All dimensions have to be considered in inches with 5% tolerance if not otherwise mentioned excluding values as per standard ASTM F2389

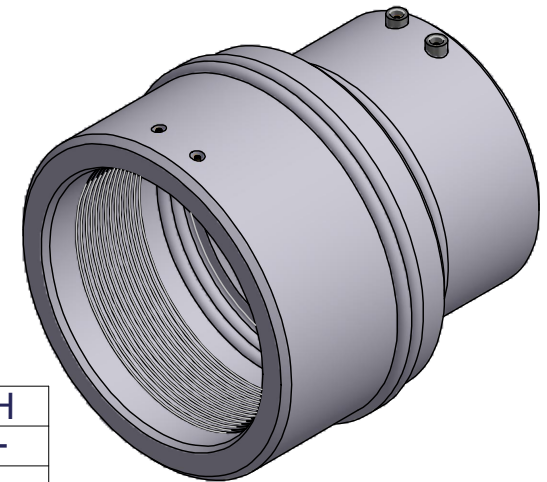
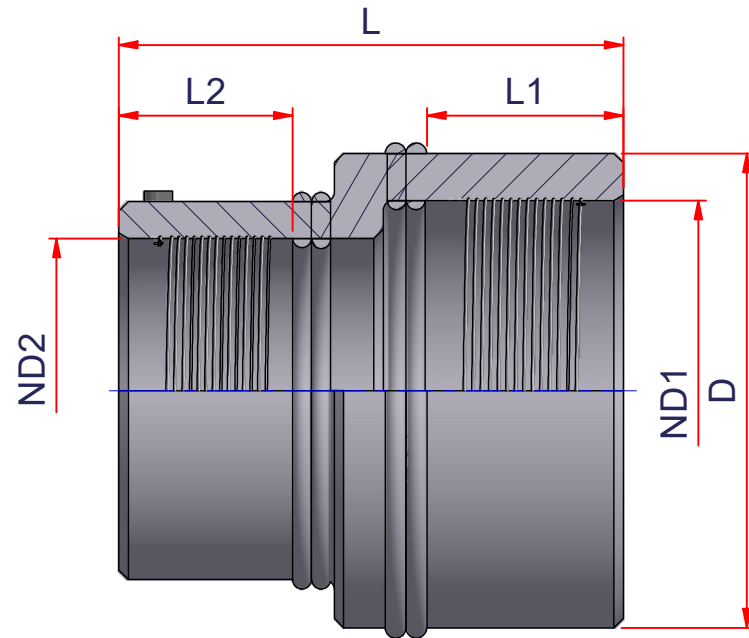

CODE	ND1	ND2	D	L1	L2	L3	L	H
27NRDE2016	8" => 200 mm	6" => 160 mm	9.84	4.1	3.62	-	10.5	-
27NRDE250200	10" => 250 mm	8" => 200 mm	11.81	4.92	4.53	-	11.95	-

NIRON



ITEM: **NRDE**

DESC: ELECTROFUSION REDUCER
SDR 11



DRAWING No:
NI10201

SHEET OF	REV.
3 3	-7

www.nupiamericas.com - info@nupiamericas.com

All dimensions have to be considered in inches with 5% tolerance if not otherwise mentioned excluding values as per standard ASTM F2389