

# M-Series and P-Series Catalog

Winter 2021

 **MITSUBISHI  
ELECTRIC**  
HEATING & AIR CONDITIONING





# Doing Our Part to Create a Better Future

## Core Environmental Policy

The Mitsubishi Electric Group promotes sustainable development and commits to protecting and restoring the global environment through technology, all business activities, and our employees' actions.

## Making Positive Contributions to the Earth and its People through Technology and Action

### Preventing Global Warming

- Reduce CO<sub>2</sub> emissions from product usage by 30%
- Reduce total CO<sub>2</sub> emissions from production by 30%
- Aim to reduce CO<sub>2</sub> emissions from power generation

### Creating a Recycling-Based Society

- Reduce, reuse and recycle product resources by 30%
- Eliminate manufacturing waste going to landfills

## Fostering Environmental Awareness Ensuring Harmony with Nature

# Mitsubishi Electric reflects the essence of this policy and vision in all aspects of its heating and air conditioning business.

## Preventing Global Warming

Heat pump technology inspires Mitsubishi Electric to design air conditioners that combine comfort and ecology. Mitsubishi Electric develops technologies to achieve greater efficiency in heat pump operation.

	Comfort	Ecology
1. Inverter	Faster start-up and more stable indoor temperature than non-inverter units.	Fewer On/Off operations than with non-inverter systems.
2. 3D i-see Sensor®	When enabled, the sensor detects the location of people within a space. Customized airflow settings to move air directly toward or away from individuals provides personalized comfort.	The sensor detects the number of people in the space. When the space is detected to be vacant, the unit enters Energy Saving operation or may be set to automatically turn off.
3. Flash Injection	Achieves high heating capacity even at low temperatures plus faster start-up compared to conventional inverters.	Expands the geographical region covered by heat pump heating systems.

### Heat Pump Principle (When Heating) <Case of COP of 5.0> Refrigerant and Heat Circulation

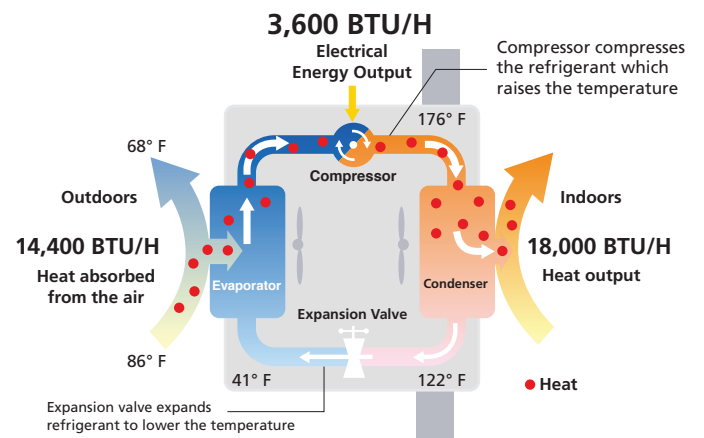



# Contents

## ■ Product Overview

Product Lineup.....	6 - 11
Quality and Testing.....	12 - 13
Inverter Technologies.....	14 - 15
Features.....	16 - 29

## ■ M-Series

M-Series.....	30 - 71
---------------	---------

## ■ P-Series

P-Series.....	72 - 109
---------------	----------

## ■ Multi-Zone Series

M-Series : Multi-zone Outdoor Units.....	110 - 117
--	-----------

## ■ Conditions

Conditions for Specifications.....	118
Piping Installation.....	119 - 123
Explanation of Terminology.....	124

## ■ Appendix

Installation in Cold Regions.....	127 - 128
System Control.....	129 - 130
Optional Parts.....	132 - 153
Additional Information.....	154 - 159
Correction Factors.....	160 - 163
External Dimensions.....	164 - 174

# M-Series Model Reference Guide

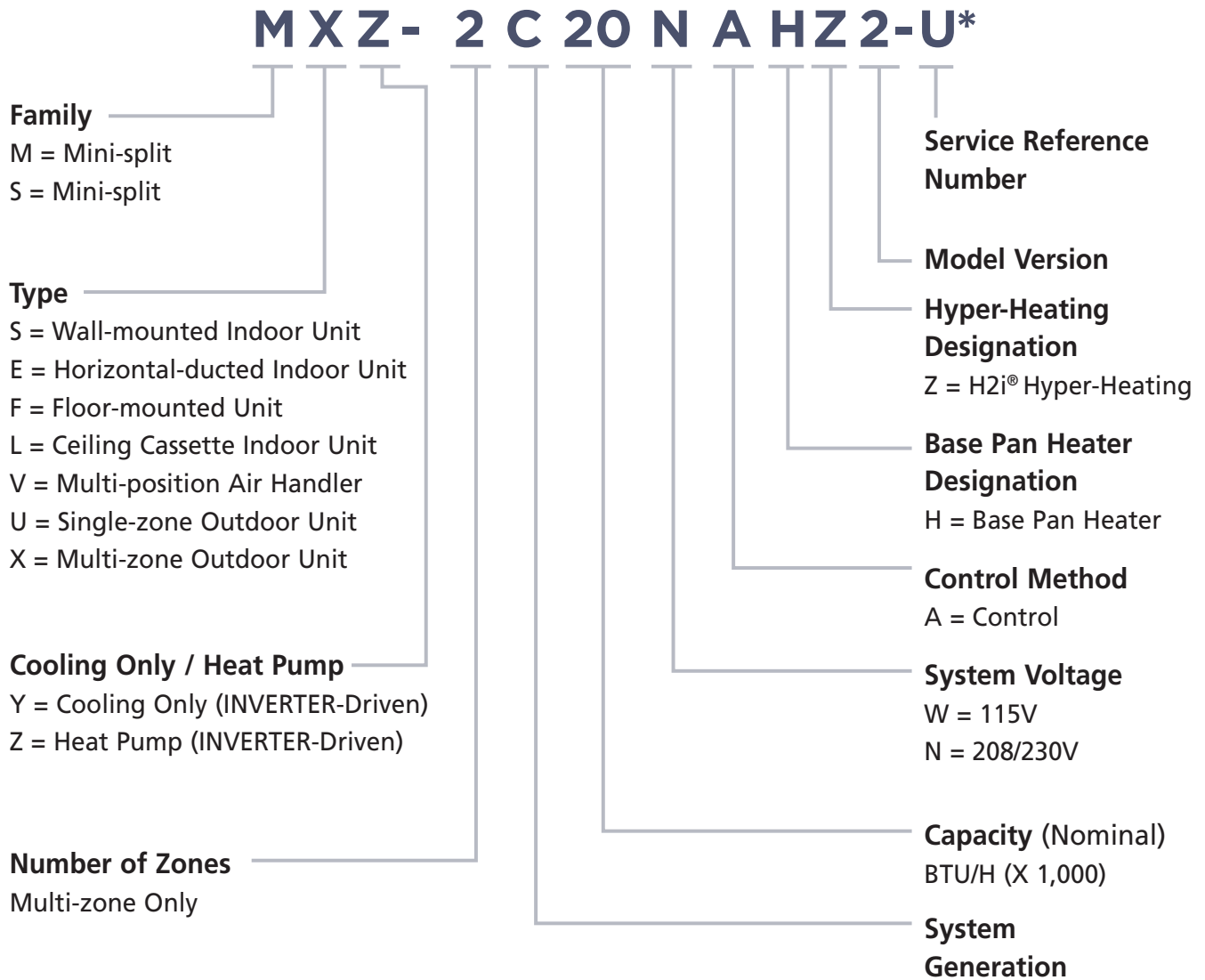





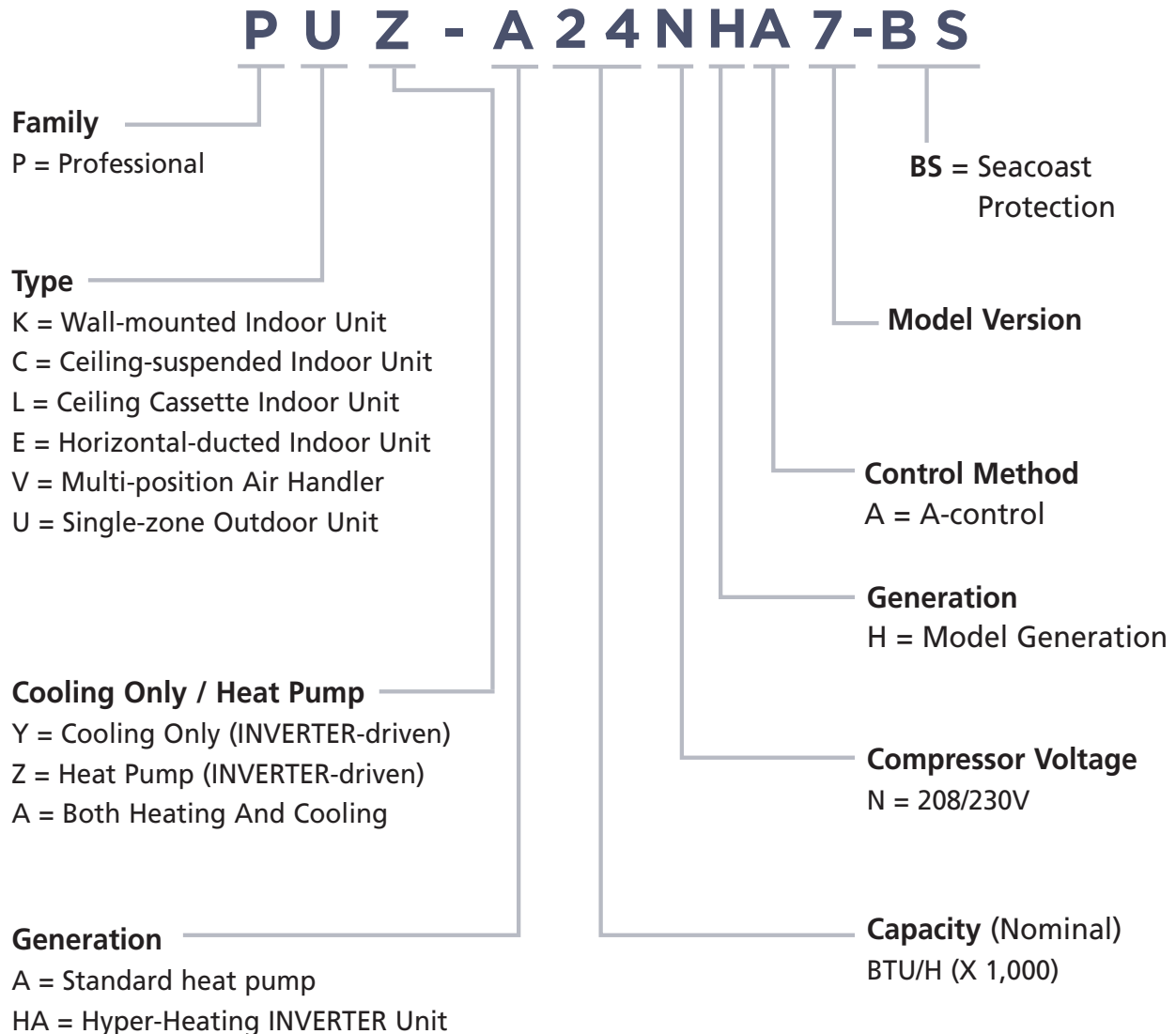







- Designed for residential applications
- User-friendly zoned cooling and heating solutions for single- or multi-room applications or the whole home
- Hyper-Heating INVERTER® (H2i®) outdoor units can provide high heating performance at lower ambient temperatures
- Many ENERGY STAR® certified models

# P-Series Model Reference Guide















- Designed for light commercial installations. Ideal for applications requiring year-round, low ambient cooling such as computer, elevator and equipment rooms
- Hyper-Heating INVERTER® (H2i®) outdoor units can provide superior heating performance at lower ambient temperatures
- Long lineset lengths
- Outside air intake on PLA, PCA, PEAD and PVA models
- P-Series ducted units have higher static than most M-Series, allowing for design flexibility

# M-Series Model Reference Guide

Model Name		6,000 BTU/H	9,000 BTU/H	12,000 BTU/H	15,000 BTU/H	18,000 BTU/H	24,000 BTU/H	30,000 BTU/H	36,000 BTU/H
Wall Mounted	MSZ-FS Model 	●	●	●	●	●			
	MSZ-EF Model 		W·S·B ● *1	W·S·B ● *1	W·S·B ● *1	W·S·B ● *1			
	MSZ-GL/D Model 	● *1	●	●	●	●	●	●	●
	MSZ-HM Model 		● *2	● *2	● *2	● *2	● *2		
	JP Model 		● *2	● *2					
	WR Model 		● *2	● *2		● *2	● *2		
	MSY-GL/D Model <small>COOLING ONLY</small> 		● *2	● *2	● *2	● *2	● *2	● *2	● *2
Floor Mounted	MFZ Model 		●	●	●	●			
EZ FIT® Ceiling Cassette	MLZ Model 		●	●		●			
Multi-position Air Handler	SVZ Model 			●		●	●	●	●
Ceiling Cassette	SLZ Model 		●	●	●	● *2			
Horizontal Ducted	SEZ Model 		●	●	●	●			

\*1 MXZ connection only \*2 Single-zone connection only  
W·S·B: Indoor units are available in three colors; White, Silver, and Black.



	Model Name	Capacity	Wall Mounted	Floor Mounted	EZ FIT® Ceiling Cassette	4-way Ceiling Cassette	Horizontal Ducted	Multi-position Air Handler	Ceiling Suspended
Heat Pump	MXZ-2C20NA2 up to 2 indoor units 	20,000 BTU/H [1-phase]	MSZ-FH06/09/12/15 MSZ-EF09/12/15 MSZ-GL06/09/12/15	MFZ-KJ 09/12/15	MLZ-KP 09/12	SLZ-KF09/12	SEZ-KD09/12/15 PEAD-A12	SVZ-KP12	
	MXZ-3C24NA2 up to 3 indoor units 	24,000 BTU/H [1-phase]	MSZ-FH06/09/12/15/18 MSZ-EF09/12/15/18 MSZ-GL06/09/12/15/18	MFZ-KJ 09/12/ 15/18	MLZ-KP0 9/12/18	SLZ-KF09/12/15 PLA-A18	SEZ-KD09/12/15/18 PEAD-A12/18	SVZ-KP12/18	
	MXZ-3C30NA2 up to 3 indoor units 	30,000 BTU/H [1-phase]	MSZ-FH06/09/12/15/18 MSZ-EF09/12/15/18 MSZ-GL06/09/12/15/18/24	MFZ-KJ 09/12/ 15/18	MLZ-KP 09/12/18	SLZ-KF09/12/15 PLA-A18	SEZ-KD09/12/15/18 PEAD-A12/18/24	SVZ-KP12/ 18/24	PCA-A24
	MXZ-4C36NA2 up to 4 indoor units 	36,000 BTU/H [1-phase]	MSZ-FH06/09/12/15/18 MSZ-EF09/12/15/18 MSZ-GL06/09/12/15/18/24	MFZ-KJ 09/12/ 15/18	MLZ-KP 09/12/18	SLZ-KF09/12/15 PLA-A18	SEZ-KD09/12/15/18 PEAD-A12/18/24	SVZ-KP12/18/ 24/30/36	PCA-A24
	MXZ-5C42NA2 up to 5 indoor units 	42,000 BTU/H [1-phase]	MSZ-FH06/09/12/15/18 MSZ-EF09/12/15/18 MSZ-GL06/09/12/15/18/24	MFZ-KJ 09/12/ 15/18	MLZ-KP 09/12/18	SLZ-KF09/12/15 PLA-A18	SEZ-KD09/12/15/18 PEAD-A12/18/24	SVZ-KP12/18/ 24/30/36	PCA-A24
	MXZ-8C48NA2 *3 up to 8 indoor units 	48,000 BTU/H [1-phase]	MSZ-FH06/09/12/15/18 MSZ-EF09/12/15/18 MSZ-GL06/09/12/15/18/24	MFZ-KJ 09/12/ 15/18	MLZ-KP 09/12/18	SLZ-KF 09/12/15 PLA-A 12/18/24/30/36	SEZ-KD 09/12/15/18 PEAD-A 12/18/24/30/36	SVZ-KP12/18/ 24/30/36	
	MXZ-8C60NA2 *3 up to 8 indoor units 	60,000 BTU/H [1-phase]	MSZ-FH06/09/12/15/18 MSZ-EF09/12/15/18 MSZ-GL06/09/12/15/18/24	MFZ-KJ 09/12/ 15/18	MLZ-KP 09/12/18	SLZ-KF 09/12/15 PLA-A 12/18/24/30/36	SEZ-KD 09/12/15/18 PEAD-A 12/18/24/30/36	SVZ-KP12/18/ 24/30/36	
Hyper Heat 	MXZ-2C20NAHZ2 up to 2 indoor units 	20,000 BTU/H [1-phase]	MSZ-FH06/09/12/15 MSZ-EF09/12/15 MSZ-GL06/09/12/15	MFZ-KJ 09/12/15	MLZ-KP 09/12	SLZ-KF09/12	SEZ-KD09/12/15 PEAD-A12	SVZ-KP12	
	MXZ-3C24NAHZ2 up to 3 indoor units 	24,000 BTU/H [1-phase]	MSZ-FH06/09/12/15/18 MSZ-EF09/12/15/18 MSZ-GL06/09/12/15/18	MFZ-KJ 09/12/15/18	MLZ-KP 09/12/18	SLZ-KF09/12/15 PLA-A18	SEZ-KD09/12/15/18 PEAD-A12/18	SVZ-KP12/18	
	MXZ-3C30NAHZ2 up to 3 indoor units 	30,000 BTU/H [1-phase]	MSZ-FH06/09/12/15/18 MSZ-EF09/12/15/18 MSZ-GL06/09/12/15/18/24	MFZ-KJ 09/12/15/18	MLZ-KP 09/12/18	SLZ-KF09/12/15 PLA-A18	SEZ-KD09/12/15/18 PEAD-A12/18/24	SVZ-KP 12/18/24	PCA-A24
	MXZ-4C36NAHZ2 *3 up to 4 indoor units 	36,000 BTU/H [1-phase]	MSZ-FH06/09/12/15/18 MSZ-EF09/12/15/18 MSZ-GL06/09/12/15/18/24	MFZ-KJ 09/12/15/1	MLZ-KP 09/12/18	SLZ-KF09/12/15 PLA-A12/18/ 24/30/36	SEZ-KD 09/12/15/18 PEAD-A12/18/ 24/30/36	SVZ-KP 12/18/24/30/36	
	MXZ-5C42NAHZ2 *3 up to 5 indoor units 	42,000 BTU/H [1-phase]	MSZ-FH06/09/12/15/18 MSZ-EF09/12/15/18 MSZ-GL06/09/12/15/18/24	MFZ-KJ 09/12/15/18	MLZ-KP 09/12/18	SLZ-KF09/12/15 PLA-A12/18/ 24/30/36	SEZ-KD 09/12/15/18 PEAD-A12/18/ 24/30/36	SVZ-KP 12/18/24/30/36	
	MXZ-8C48NAHZ2 *3 up to 8 indoor units 	48,000 BTU/H [1-phase]	MSZ-FH06/09/12/15/18 MSZ-EF09/12/15/18 MSZ-GL06/09/12/15/18/24	MFZ-KJ 09/12/15/18	MLZ-KP 09/12/18	SLZ-KF09/12/15 PLA-A12/18/ 24/30/36	SEZ-KD 09/12/15/18 PEAD-A12/18/ 24/30/36	SVZ-KP12/18/ 24/30/36	

\*3 The number of indoor units are limited when connected to PLA. For more information, please refer to pg.85-86 The number of ducted models (SVZ, SEZ, PEAD) connectable may be limited based on the outdoor unit and combination - refer to the compatibility charts.

# P-Series

## Cooling Only Models (PUY)

Model Name		12,000 BTU/H	18,000 BTU/H	24,000 BTU/H	30,000 BTU/H	36,000 BTU/H	42,000 BTU/H
4-way Ceiling Cassette	PLA Model 	•	•	•	•	•	•
Wall Mount	PKA Model 	•	•	•	•	•	
Multi-Position Air Handler	PVA Model 	•	•	•	•	•	•
Horizontal Ducted	PEAD Model 	•	•	•	•	•	•
Ceiling-Suspended	PCA Model 			•	•	•	•

## Heat Pump Models (PUZ)

Model Name		12,000 BTU/H	18,000 BTU/H	24,000 BTU/H	30,000 BTU/H	36,000 BTU/H	42,000 BTU/H
4-way Ceiling Cassette	PLA Model 	•	•	•	•	•	•
Wall Mount	PKA Model 	•	•	•	•	•	
Multi-Position Air Handler	PVA Model 	•	•	•	•	•	•
Horizontal Ducted	PEAD Model 	•	•	•	•	•	•
Ceiling-Suspended	PCA Model 			•	•	•	•



## Hyper-Heating Models (PUZ-HA)

Model Name		24,000 BTU/H	30,000 BTU/H	36,000 BTU/H	42,000 BTU/H
4-way Ceiling Cassette	PLA Model 	●	●	●	●
Wall Mount	PKA Model 	●	●	●	
Multi-Position Air Handler	PVA Model 	●	●	●	●
Horizontal Ducted	PEAD Model 	●	●	●	●
Ceiling-Suspended	PCA Model 	●	●	●	●



# Quality and Testing

## Quality First. Always.

Cutting edge technologies and uncompromising commitment to quality and reliability have made us one of the world's most trusted brands in air conditioning and refrigeration equipment and service.

## Development

### Operating Tests in Harsh Conditions

Harsh environmental conditions of cold regions are simulated for the development of our air conditioners. This is another reason customers in severely cold regions rely on us for comfortable heating.



### Combustion Test

Products are subjected to a wide range of tests including combustion testing, all to confirm safe operation under a variety of conditions. Combustion testing is done by assuming accidental firing and replicating abnormal conditions that cause breakage of pressure components.



Explosion-proof chamber

### Shock Resistance

On the assumption of many different kinds of logistics environments in the world, we perform drop/strength tests, transport vibration tests, and many other product checks to assure that the quality and performance are maintained when the product reaches the user's home.



Drop/strength testing



Transport vibration testing

### **Waterproof and Corrosion Test**

Since the outdoor unit is subject to rain, wind, and corrosive substances, potential problems are checked by tests such as showering the unit for a certain amount of time and increasing protection to enhance the lifespan of the unit.



### **Operation Noise Test**

Operation noise tests are performed in an anechoic chamber with an extremely low 10 dB(A) of background noise. This is just one of the ways we ensure our customers enjoy extremely quiet air conditioners with a minimum operation noise of 19 dB(A) (sound pressure level).



Anechoic chamber

## **Design**

### **Designed to create and maintain a comfortable environment**

To improve the quality of products, engineers strive to achieve our philosophy of combining comfort and ecology in an effort to continually raise the bar. Therefore, we are working to further improve quality at all stages from development to production.



## **Production**

### **Each and every unit is checked and double-checked by experienced professionals**

Every air conditioner goes through a rigorous electrical inspection on the manufacturing line. In final testing, our experienced inspectors listen for even the faintest operation noise to detect any defect.



# INVERTER Technologies

Our Promise: Mitsubishi Electric inverters ensure superior performance including the optimum control of operation frequency. As a result, optimum power is applied in all heating/cooling ranges and maximum comfort is achieved while consuming minimal energy. Fast, comfortable operation and amazingly low running cost — that's the Mitsubishi Electric promise.

## How Inverters Work

Inverters electronically control the electrical voltage, current and frequency of electrical devices such as the compressor motor in an air conditioner. They receive information from sensors monitoring operating conditions, and adjust the revolution speed of the compressor, which directly regulates air conditioner output. Optimum control of operation frequency results in eliminating the consumption of excessive electricity and providing the most comfortable room environment.

## Economic Operation

Impressively low operating cost is a key advantage of inverter air conditioners. We've combined advanced inverter technologies with cutting edge electronics and mechanical technologies to achieve a synergistic effect that enables improvements in heating/cooling efficiency. Better performance and lower energy consumption are the result.

## True Comfort

Below is a comparison of air conditioner operation control with and without an inverter.

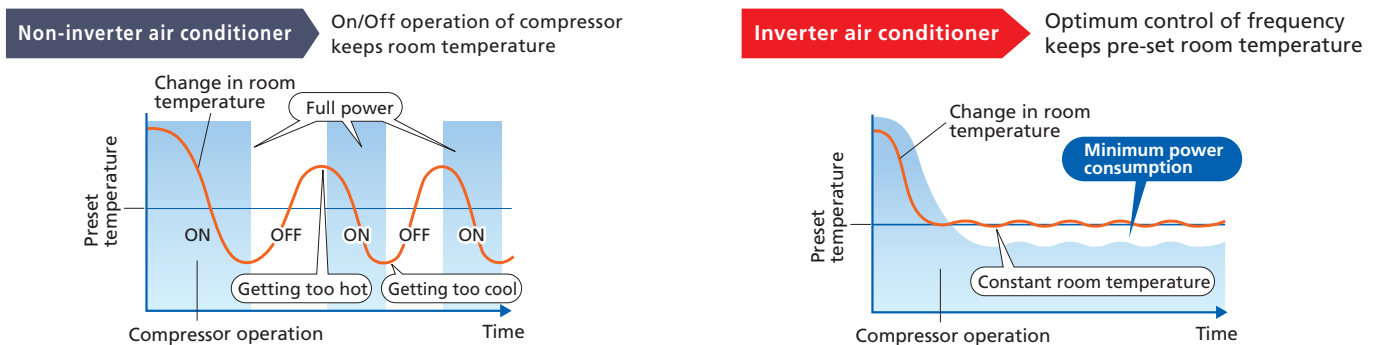

The compressors of air conditioners without an inverter start and stop repeatedly in order to maintain the preset room temperature. This repetitive on/off operation uses excessive electricity and compromises room comfort. The compressors of air conditioners equipped with an inverter run continuously; the inverter quickly optimizing the operating frequency according to changes in room temperature. This ensures energy-efficient operation and a more comfortable room.

### POINT 1 Quick & Powerful

Increasing the compressor motor speed by controlling the operation frequency ensures powerful output at start-up, brings the room temperature to the comfort zone faster than units not equipped with an inverter. Hot rooms are cooled and cold rooms are heated faster and more efficiently.

### POINT 2 Room Temperature Maintained

The compressor motor operating frequency and the change of room temperature are monitored to calculate the most efficient waveform to maintain the room temperature in the comfort zone. This eliminates the large temperature swings common with non-inverter systems and guarantees a pleasant, comfortable environment.

## Key Technologies

### Our Rotary Compressor

Our rotary compressors use our original Poki-Poki Motor and Heat Caulking Fixing Method to achieve a compact-high-efficiency unit. They are designed to be used in various residential and commercial applications. In addition, the Divisible Middle Plate production method realizes even more size and weight reductions while increasing capacity and meeting energy efficiency needs.

### Room Temperature Maintained

Our scroll compressors are equipped with an advanced frame compliance mechanism that allows self-adjustment of the position of the orbiting scroll according to pressure load and the accuracy of the fixed scroll position. This minimizes gas leakage in the scroll compression chamber, maintains cooling capacity, and reduces power loss.

## More Advantages With Our Products

### Joint Lap DC Motor

Mitsubishi Electric has developed a unique motor, called the Poki-Poki Motor in Japan, manufactured using a joint lapping technique. This innovative motor operates based on a high-density, high-magnetic force, leading to extremely high efficiency and reliability.



### Magnetic Flux Vector Sine Wave Drive

This drive device is a microprocessor that converts the compressor motor's electrical current waveform from a conventional waveform to a sine wave (180°conductance) to achieve higher efficiency by raising the motor winding utilization ratio and reducing energy loss.

### Reluctance DC Rotary Compressor

Powerful neodymium magnets used in the reluctance DC motor rotor produce strong magnetic torque and reluctance torque resulting in more efficient operation.

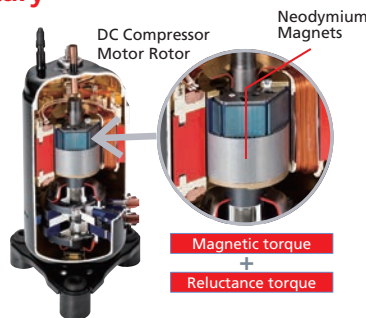

### Highly Efficient DC Scroll Compressor

Adding a frame compliance mechanism to the DC scroll compressor achieves further efficiency. The mechanism allows movement in the axial direction of the frame supporting the cradle scroll, thereby significantly reducing leakage and friction loss and ensuring high efficiency at all speeds.

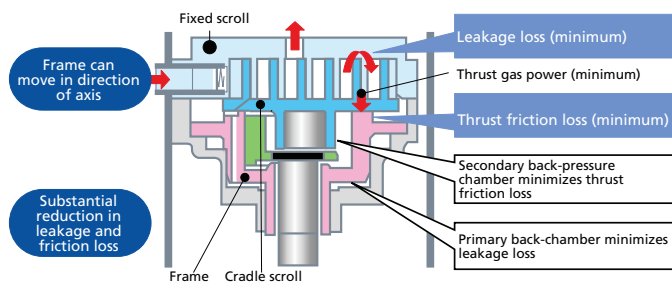

### Heat Caulking Fixing Method

A Heat Caulking Fixing Method replaced arc spot welding to secure internal parts in place. This change reduces the distortion of internal components resulting in additional efficiency gains.

### Room Temperature Maintained

The inverter monitors the varying compressor motor frequency and creates the most efficient waveform for the motor speed. This results in improving operating efficiency at all speed ranges, using less power, and reducing annual electricity costs.

#### Smooth Wave Pattern

The synthetic resin is molded with the circuit pattern to reduce the inverter size. Using soft PWM control to eliminate the metallic whine associated with conventional inverters achieves quieter operation.

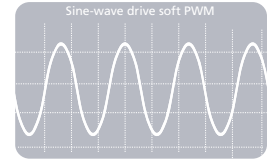

### PAM (Pulse Amplitude Modulation)

PAM is a technology controlling the current waveform to resemble the supply voltage wave resulting in reduced loss and more efficient electricity use. PAM control effectively utilizes 98% of the input power supply.

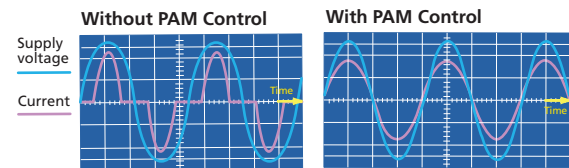

#### Merits of PAM Control

Significant energy savings with remarkable reduction in power loss saves electricity

Power increased  
Efficient voltage increase realizes increased power

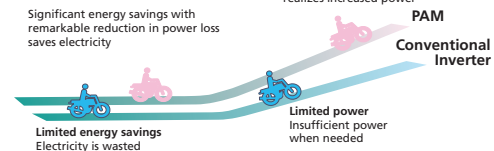

### Power Receiver and Twin LEV Control

Mitsubishi Electric developed a power receiver and twin linear expansion valve (LEVs) circuit that optimize compressor performance. This technology ensures ultimate control in response to the operating waveform and outdoor temperature. Tailoring the system to the characteristics of R410A refrigerant improves operational efficiency.

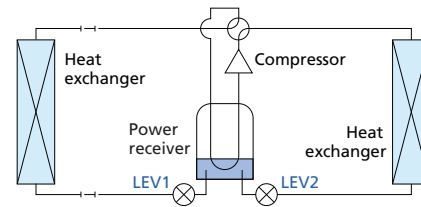

### Grooved Piping

High-performance grooved piping is used in heat exchangers to increase the heat exchange area.

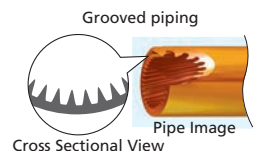

### DC Fan Motor

A highly efficient DC motor drives the fan of the outdoor unit. Efficiency is much higher than an equivalent AC motor.

# Features

## 3D i-see Sensor for FS Model

The FS Model comes equipped with a 3D i-see Sensor®, an infrared-ray sensor that measures temperatures at different positions throughout the space. While scanning the area from left to right, eight vertically arranged sensor elements analyze the room temperature in three dimensions. Based on temperature readings, the sensor detects the location of people in the room. This technology enables the user to personalize comfort by selecting their preferred airflow setting.

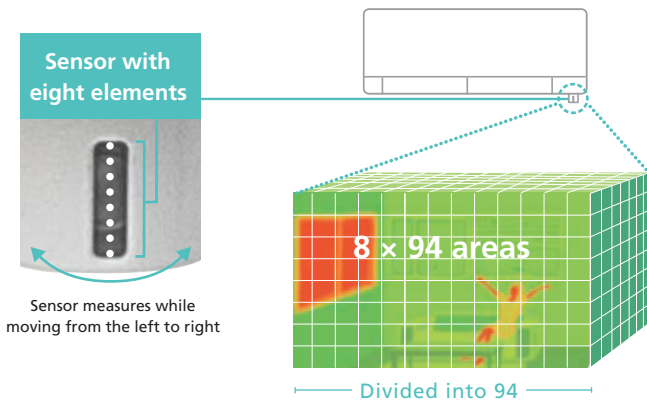

### Indirect Airflow

The Indirect Airflow setting diverts airflow away from people within the space.



### Direct Airflow

The Direct Airflow setting blows conditioned air toward people within the space.



### Absence Detection

The sensors detect whether there are people in the room. When no one is in the area, the unit automatically switches to Energy Saving Mode.



When the 3D i-see Sensor detects an unoccupied room, the power consumption reduces by ~10% after 10 minutes and further decreases by ~20% after 60 minutes.

## 3D i-see Sensor for SLZ and PLA Models

### Detects Number Of People

The 3D i-see Sensor detects the number of people in the room and adjusts the power accordingly. This saves energy in places where the number of people changes frequently. Additionally, when the area is continuously unoccupied, the system switches to an advanced Power Saving Mode. Depending on the setting, it can also stop the operation.



Detects number of people

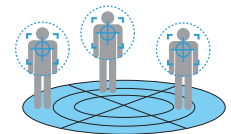

Detects the Location of Individuals

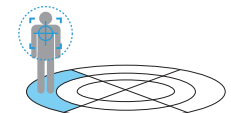

### Detects the Location of Individuals

The airflow in the space is entirely customizable. The user can choose Direct Airflow or Indirect Airflow configurations for each of the four air vanes. Once the sensor detects a person within the area, each air vane adjusts automatically to the preferred settings.

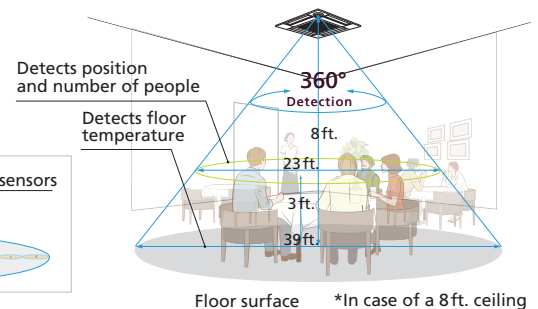
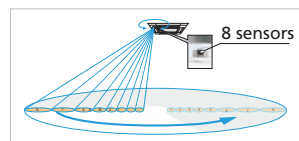

### Highly Accurate Temperature Measurements

A total of eight sensors rotate a full 360° in 3-minute intervals. The sensor measures temperature throughout the space, plus the algorithm determines the number of people within the area and their locations.



## Determines Occupancy

### Room Occupancy Energy Saving Mode

The 3D i-see Sensor® detects the number of people in the room. It calculates the actual occupancy rate as a percentage of the maximum number of people. When the occupancy rate is approximately 30%, the system energy savings is equivalent to 2° F during cooling or heating operation. The Energy Saving Mode algorithm controls the room temperature based on space occupancy.

### No Occupancy Energy Saving Mode

When the 3D i-see Sensor detects that no one is in the room, the system switches to a preset power-saving mode. If the area remains unoccupied for more than 60 min, the system energy savings is equivalent to 4° F during cooling or heating operation. This mode reduces energy wasted on heating and cooling unoccupied rooms.

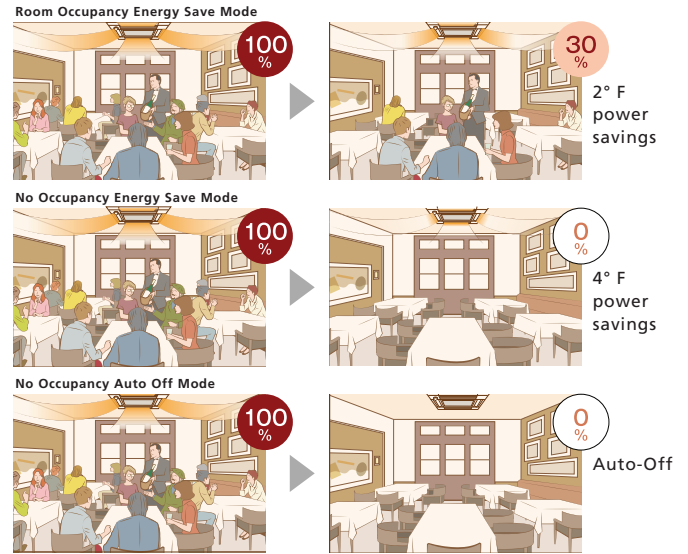

\*PAR-40MAAU is required for each setting

### No occupancy Auto Off Mode

When the room remains unoccupied for a predetermined amount of time, the system automatically turns off. The time duration the system remains off can be configured in 10-minute increments ranging from 60 minutes to 180 minutes.

## Detects the Location of Individuals

### Seasonal Airflow\*

#### When Cooling:

The unit saves energy while keeping a comfortable temperature by automatically switching between ventilation and cooling modes. Once the room reaches the desired temperature, the system switches from cooling mode to swing-fan operation to extend the amount of time the space maintains set point.

#### When Heating:

Once the room reaches the temperature set point, the system switches from heating mode to fan mode. The fan recirculates conditioned air throughout the space to prevent heated air from being wasted by collecting at the ceiling. This feature improves room comfort by eliminating annoying temperature differences caused by air stratification.

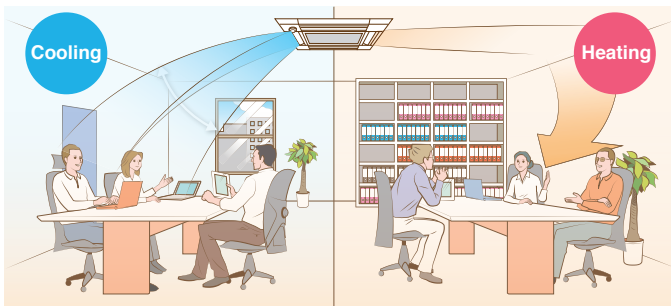

\*PAR-40MAAU is required for each setting.

### Direct/Indirect Settings\*

When set to Indirect Airflow, the vanes direct air horizontally across the ceiling away from individuals eliminating drafts.



\*PAR-40MAAU is required for each setting.

### AREA Area Temperature Monitor

The 3D i-see Sensor monitors the whole room in small sections and directs the airflow to regions within the space as needed. For example, if the system is in cooling mode and the middle of the room is hot, then more airflow is directed toward the problem area to even out the room temperature. This smart feature eliminates unnecessary heating and cooling costs while delivering more uniform temperatures and comfort throughout the room.

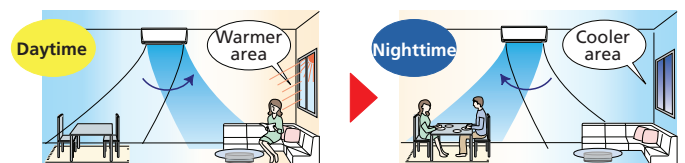

Cooling Mode

## Energy-Saving

### Econo Cool Mode

Econo Cool is an intelligent temperature control feature that adjusts the amount of air directed towards the body based on discharge air temperature. The set point can be raised by 4° F without any loss in comfort, achieving an additional 20% energy efficiency.

(Function only available during manual cooling operation.)

	Conventional	Econo Cool
Ambient Temperature	95° F	95° F
Set Point	77° F	81° F
Perceived Temperature	86° F	85° F

Econo Cool

Conventional Cooling Mode

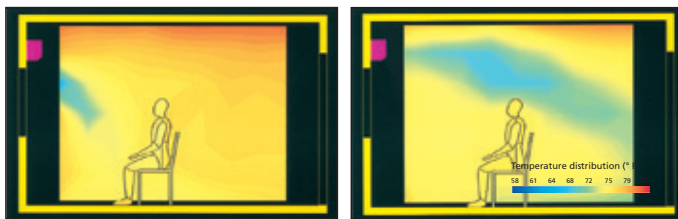

## Air Quality

### Nano Platinum Filter

This filter has a large capture area and incorporates nanometer-sized platinum-ceramic particles that work to kill bacteria and deodorize the circulating air.

### Catechin Filter

Catechin is a bioflavonoid by-product of green tea with both antiviral and antioxidant qualities. In addition to improving air quality, it prevents the spreading of bacteria and viruses throughout the room, and also has an excellent deodorizing effect.

### Air Filter

This filter removes dust particles from the air.

### Deodorizing Filter

The catalyst coating on the honeycomb-structured frame captures small foul-smelling substances in the air, then breaks down the source of the odors with the power of the ozone generated in a plasma electrode unit.

### Electrostatic Anti-Allergy Enzyme Filter

This filter is charged with static electricity, enabling it to attract and capture dust particles that regular filters cannot capture. This filter can also trap allergens such as bacteria and decompose them using enzymes retained in the filter.

### Demand Function (On-site Adjustment)

Based on the signal input, energy consumption can be reduced up to 100% of the typical consumption. The demand function can be activated by a commercially available timer or an on/off switch added to the CNDM connector (optional) on the outdoor unit control board.

[Example: P-Series]

Limit energy consumption by changing the settings of SW7-1, SW1 and SW2 on the control board of the outdoor unit. The following settings are possible.

SW7-1	SW1	SW2	Energy Consumption
ON	OFF	OFF	100%
	ON	OFF	75%
	ON	ON	50%
	OFF	ON	0% (Stop)

\* PUY/PUZ outdoor only

### Air Purifying Filter

The filter has a large capture area and deodorizes the circulating air.

### Fresh-air Intake

The direct intake of fresh exterior air enhances indoor air quality.

### High-efficiency Filter

This high-performance filter has a much finer mesh compared to standard filters, and is capable of capturing minute particulates floating in the air that were not previously caught.

### Oil Mist Filter

The oil mist filter prevents oil mist from penetrating the inner part of the air conditioner.

### Long-life Filter

A special process for the entrapment surface improves the filtering effect, making the maintenance cycle longer than that of units equipped with conventional filters.

### Filter Check Signal

The system monitors the air conditioner operating time, and the user is notified when filter maintenance is necessary.

## Air Distribution

### Double Vane

The double vane separates airflow into different directions to supply air across a wide area of the room and also reach people in two separate locations.

### Natural Flow Operation

Airflow becomes more like a light breeze, and the occupant feels more comfortable.

### Indirect/Direct Mode

This mode offers finely-tuned operation by locating where an occupant is in the room and sends the air directly or indirectly according to the selected mode.

### Powerful Operation

The air conditioner will automatically adjust the fan speed and set temperature for 15 minutes. Rapid cooling and heating will make the room comfortable more quickly.

### Wide Airflow

Especially beneficial for large spaces, helping to ensure that the air is well circulated and reaches every corner of the room. Select the desired airflow pattern and it will distribute air horizontally over a wide-ranging 150° in heating mode and 100° in cooling mode.

### Vertical Vane

The air outlet fin swings from side to side so that the airflow reaches every part of the room.

### High Ceiling Mode

In the case of rooms with high ceilings, the outlet-air volume can be increased to ensure that air is circulated all the way to the floor.

### Low Ceiling Mode

If the room has a low ceiling, the airflow volume can be reduced for less draft.

### Auto Fan Speed Mode

The airflow speed mode adjusts the fan speed of the indoor unit automatically according to the present room conditions.

### Auto Vane Control

Outlet vanes can be moved left and right, and up and down using the remote controller. This improved airflow control feature solves the problem of drafts.

### Horizontal Vane

The air outlet vane swings up and down so that the airflow is spread evenly throughout the room.

## Blue Fin Coating

### Blue Fin Heat Exchanger

Anti-corrosion treatment is applied to the heat exchanger of the outdoor units. This coating prevents the corrosion of the aluminum fins caused by salt in the air, especially in coastal areas. (Corrosion of the heat exchanger will affect the efficiency and performance of the air conditioner.)

### Standard HEX coatings:

Rated for 240 hours spraying time\*

### Blue Fin HEX coatings:

Rated for 960 hours spraying time\*

\*Per JRA 9002 Standard Coating is applied on all M-Series single-zone outdoor units

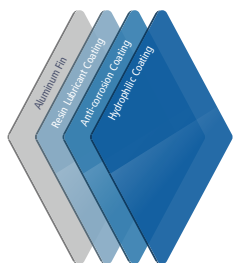

Blue Fin HEX

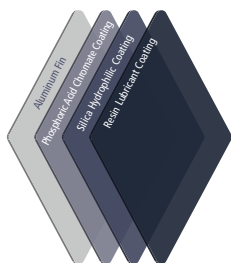

Standard HEX

Compatibility	
Outdoor Unit	Blue Fin Coating
MUZ-FS	•
MUFZ-KJ	•
MUZ/Y-GL	•
MUZ-HM	•
MUZ-JP	•
MUZ-WR	•
SUZ-KA-NA2 (9, 12, 15)	•
SUZ-KA-NAHZ (9, 12, 15, 18)	•
PUZ/Y-BS (Sea coast protection models only)	•
MXZ-NA2/NAHZ2 Multi-zone (Branch box type)	•

## Convenience

### Smart Set

Smart Set is a simplified setting function that recalls the preferred (preset) temperature by pressing a single button on the remote controller. Press the same button twice in repetition to immediately return to the previous temperature setting. Using this function contributes to comfortable waste-free operation, realizing the most suitable air conditioning settings and saving on power consumption when, for example, leaving the room or going to bed.

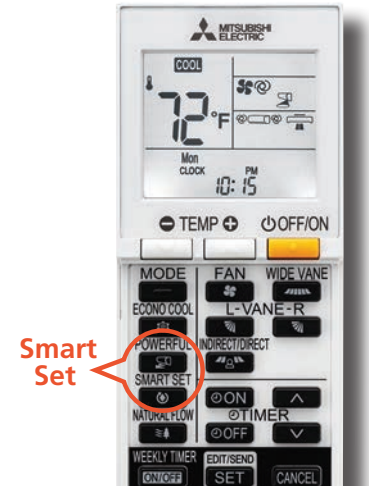
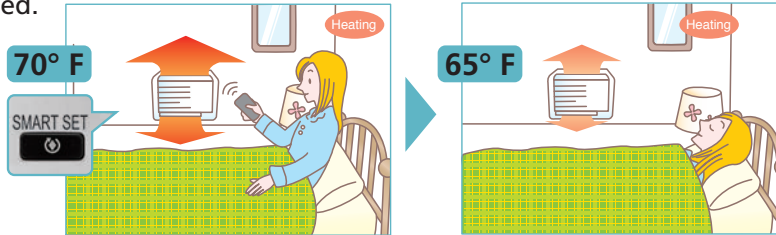

### Auto Changeover

The air conditioner automatically switches between heating and cooling modes to maintain the desired temperature.

### Low-Temperature Cooling

Intelligent fan speed control in the outdoor unit ensures optimum performance even when the outside temperature is low.

### Ampere Limit Adjustment

Dip switch settings can be used to adjust the maximum electrical current for operation. This function is highly recommended for managing energy costs.

\*Maximum capacity is lowered with the use of this function

### Auto Restart

Especially useful at the time of power outages, the unit turns back on automatically when power is restored.

### Operation Lock (Outdoor Unit)

To accommodate specific-use applications, cooling or heating operation can be specified when setting the control board of the outdoor unit. A convenient option when a system needs to be configured for exclusive cooling or heating service.

### Sleep Mode

When Sleep Mode is activated using the wireless remote controller, it will switch to the settings described below.

- After 30 minutes, the set temperature will automatically change to the sleep mode set temperature, which the user can set beforehand.
- The fan speed will immediately change to low fan speed.

### On/Off Operation Timer

Use the remote controller to set the times of turning the air conditioner On/Off.

FS Remote - Closed



FS Remote - Open

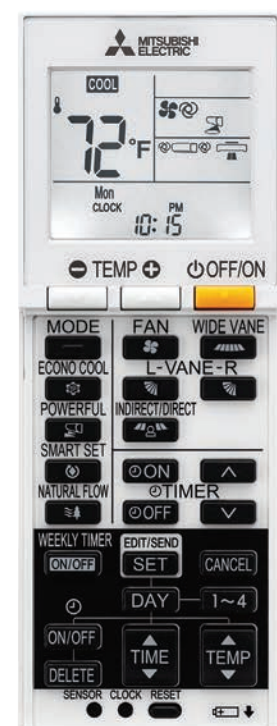



## Weekly Timer Function

Easily set desired temperatures and operation ON/OFF times to match lifestyle patterns. Reduce wasted energy consumption by using the timer to prevent forgetting to turn off the unit and eliminate temperature setting adjustments.

### Sample Operation Pattern (Winter/Heating mode)

	Mon.	Tues.	Wed.	Thurs.	Fri.	Sat.	Sun.
6:00 AM	ON 68°F	ON 68°F	ON 68°F	ON 68°F	ON 68°F	ON 68°F	ON 68°F
8:00 AM	Automatically changes to high-power operation at wake-up time						
10:00 AM	OFF	OFF	OFF	OFF	OFF	ON 64°F	ON 64°F
12:00 AM	Automatically turned off during work hours					Midday is warmer, so the temperature is set lower	
2:00 PM							
4:00 PM							
6:00 PM	ON 72°F	ON 72°F	ON 72°F	ON 72°F	ON 72°F	ON 72°F	ON 72°F
8:00 PM	Automatically turns on, synchronized with arrival at home					Automatically raises temperature setting to match time when outside-air temperature is low	
10:00 PM							
(during sleeping hours)	ON 64°F	ON 64°F	ON 64°F	ON 64°F	ON 64°F	ON 64°F	ON 64°F
	Automatically lowers temperature at bedtime for energy-saving operation at night						

#### Settings

**Pattern Settings:** Input up to four settings for each day

**Settings:** • Start/Stop operation • Temperature setting \*The operation mode cannot be set.

## Easy Set-Up Using Dedicated Buttons

The remote controller is equipped with buttons that are used exclusively for setting the Weekly Timer. Setting operation patterns is easy and quick.

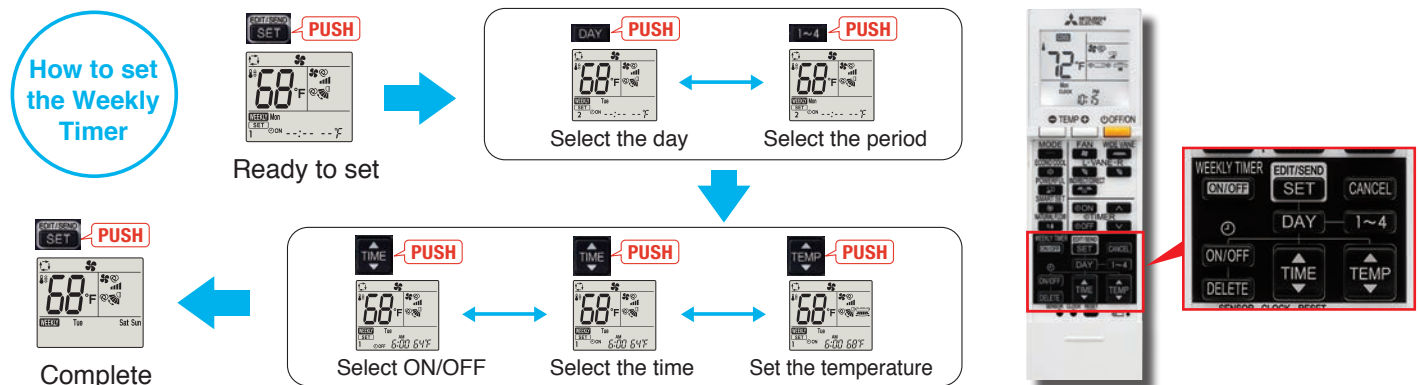

## Set a Weekly Timer

Start by pushing the "SET" button and follow the instructions to set the desired patterns. Once all of the desired patterns are input, point the top end of the remote controller at the indoor unit and push the "SET" button one more time. (Push the "SET" button only after inputting all of the desired patterns into the remote controller memory. Pushing the "CANCEL" button will end the set-up process without sending the operation patterns to the indoor unit). It takes a few seconds to transmit the Weekly Timer operation patterns to the indoor unit. Please continue to point the remote controller at the indoor unit until all data has been sent.

## System Control



### M-NET Connection

Units can be connected to MELANS system controllers (M-NET controllers) such as the AE-200A.



### kumo cloud® Wireless Interface

Along with your smart phone or tablet device, you can manage your system in multiple venues, such as home, work and vacation locations. You can control functions like turning on/off, fan speed, and vane direction.



### MXZ Connection

Connection to the MXZ multi-split outdoor unit is possible.



### System Group Control

The same remote controller is capable of controlling the operational status of up to 16 refrigerant systems.



## Anytime, Anywhere Control

kumo cloud gives you the ability to control your home's comfort effortlessly. Whether you're out for the day or out for the month, looking to cool down or warm up, kumo cloud gives you control from any smart device or web browser.

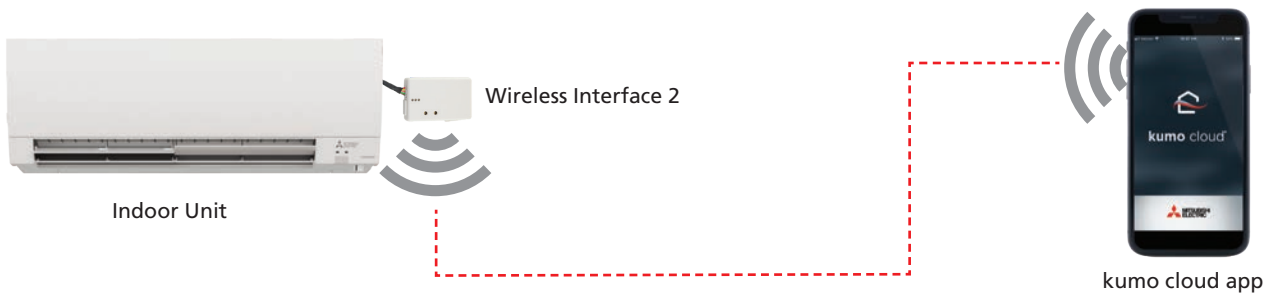
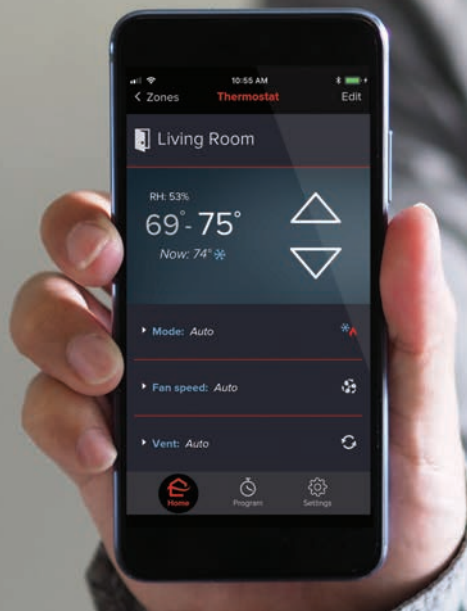

## Manage Your Comfort From Anywhere with kumo cloud

- Now compatible with M-Series, P-Series, and CITY MULTI® systems
- kumo cloud allows for a Mitsubishi Electric indoor unit to be controlled remotely or locally with the app
- For product information, go to [kumocloud.com](http://kumocloud.com)
- Ability to group indoor units and organize groups into sites
- Batch command indoor units
- Ability to program events and scheduling into the unit itself
- Available in Fahrenheit or Celsius
- Easy to connect the device to home router using the kumo cloud app
- Each indoor unit must be equipped with a Wireless Interface (PAC-USWHS002-WF-2) installed by a licensed contractor
- Secure boot to prevent unauthorized reprogramming of the Wireless Interface
- Intuitive initial settings feature for M- & P-Series equipment
- Compatible with Amazon Alexa and Google Home

### Program and Schedules

kumo cloud setup walks through a simple five-step process to easily schedule modes, program set points, and select fan speeds for all zones or one at a time.

### Easily Zoned

The kumo cloud app discovers active Wireless Interface devices. Once located, each zone can be named and organized into groups.

### Check Filter Status

You never have to manually check a filter again. kumo cloud can tell you the status of any filter in your system at any time.

# kumo touch™

Simple wall-mounted design controllers can be installed anywhere with large, backlit, easy to read display. Both the controller and receiver is enabled with RedLINK reliability.

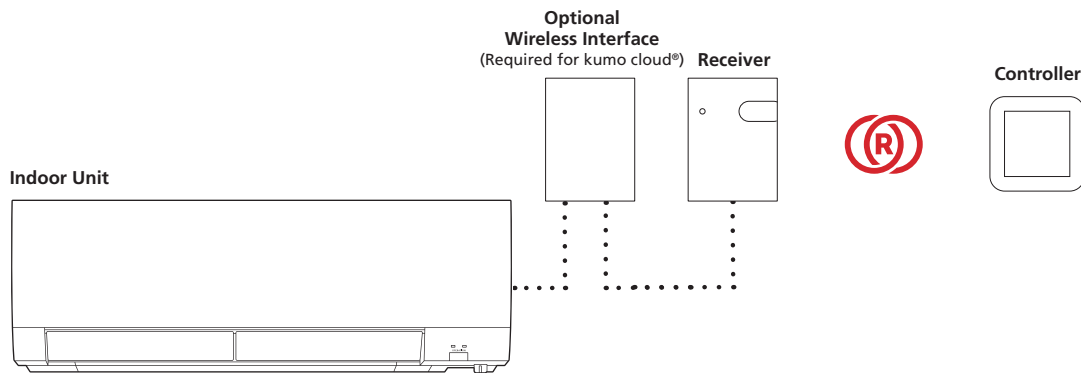

## MRCH2 kumo touch Controller Specifications

- Touch panel, Back lit, easy-to-read display
- Used RedLINK™ 3.0 wireless technology
- Not compatible with MHK1, MOS1, and MCCH1 RedLINK 2.0 wireless technology environment
- User functions allow user to set:
  - On/Off
  - Operation modes cool, heat, drying, fan
  - Set temperature (separate dual set points for heat and cool)
  - Fan speed setting
  - Airflow direction
  - Set temperature range limits (dependent on the system connected):
    - Cooling from 50° to 99° F
    - Heating from 40° to 90° F
    - Auto from 50° to 90° F with dual temperature setting
  - MHK2 Scheduling options:
    - No Schedule
    - MO-SU = Every day the same
    - MO-FR, SA, SU = 5-1-1 schedule
    - MO-FR, SA-SU = 5-2 schedule
    - Each Day = Every day individual
    - Allow kumo cloud to be schedule holder
    - Hold function
    - Temporary or Permanent schedule override
    - Lockout:
      - On, Off, Mode, Fan Speed, Set point, Vane Direction
    - Day/Time display with a 12 or 24-hour clock
    - Supports both Fahrenheit and Celsius
    - RedLINK™ Wireless Connection Status
    - Filter sign display
  - Diagnostics: Displays and records error codes
  - Adjustable auto mode deadband
  - Space temperature offset adjustment
  - Space humidity offset adjustment
  - Hide (on screen only)

- Indoor temperature
- Indoor humidity
- Temperature Sensing Source

## MHK2 Specifications

- Indoor Unit
- RedLINK Wireless Indoor Air Sensor (IAS)
- Average of MHK2 and RedLINK Wireless Indoor Air Sensor (IAS)
- Indoor Humidity Source
- MHK2
- RedLINK Wireless Indoor Air Sensor (IAS)
- Average of MHK2 and RedLINK Wireless Indoor Air Sensor (IAS)
- Improved indoor unit function code list
- Indoor unit type
- Expanded to 28 indoor unit codes
- Reset to factory default
- Uses two "AA" alkaline batteries (included)
- Dimensions: 4-5/64" x 4-5/64" x 1-1/16" (104 x 104 x 27 mm)
- Operating Ambient Temperature: 32° to 120° F (0° to 48.9° C)
- Operating Relative Humidity: 5% to 90%

## MIFH2 Wireless Receiver Specifications

- Included in MHK2 Kit
- Mounts next to or near indoor units to allow MRCH2 Remote Controller operation
- Connects to indoor unit control board with MRC2 Cable
- Dimensions: 3-3/32" H x 1-3/4" W x 39/64" D (74.8 x 44.4 x 15.4 mm)
- Operating Ambient Temperature: -40° to 165° F (-40° to 73.9° C)
- Operating Relative Humidity: 5% to 95%

## MRC2 Cable

- Included in MHK2 Kit in the MIFH2 box
- Connects MIFH2 Wireless Receiver to the CN105 connector on indoor unit control board
- Length: 39-23/64" (1 m)



Apple and the App Store are registered trademarks of Apple, Inc. Amazon, Alexa, Fire and all related logos are trademarks of Amazon.com, Inc. or its affiliates. Google play is a registered trademark of Google, Inc.

# Wired Controllers

## Simple MA Remote Controller



PAC-YT53CRAU-J

- Controls group operation for up to 16 indoor units in a single group
- Supports Fahrenheit and Celsius
- User defined functions:
- On/Off
- Operation modes: Heat/Cool/Auto/Dry
- Fan speed setting
- Airflow direction
- Set temperature range: 40° F to 95° F depending on operation mode and indoor unit connected
- Set temperature range limit for cool and heat modes
- LOSSNAY®: Simple MA for interlocked system can set high/low/stop on LOSSNAY
- Room temperature can be sensed either at indoor unit (default) or at the remote controller
- Dimensions: 2-3/4" W x 9/16" D x 4-3/4" H
- Requires MAC-334IF-E for use with M-Series products

## Deluxe MA Remote Controller



PAR-40MAAU

- User defined functions:
- On/Off
- Operation modes: Heat/Cool/Auto/Dry
- Room temperature setting & Temperature range restriction
- Manual vane angle (P-Series cassette indoor units)
- Smooth maintenance (P-Series only)
- Auto-off timer & Weekly timer
- Setting screen for 3D i-see Sensor®
- Draft reduction mode
- Daylight Saving Time (DST)
- Dimensions: 4-3/4"W x 3/4"D x 4-3/4"H
- Requires MAC-334IF-E for use with M-Series ductless products
- Room temperature displays room temperature sensed either at the indoor unit (default) or at the controller

## Deluxe MA Remote Controller



PAR-CT01MAU-SB

- User-friendly, customizable full color touch panel display
- Ability to add a custom logo on the display
- Large icons with 180 color patterns
- Daily and weekly timers
- Password protected
- Requires MAC-334IF-E for use with M-Series products
- The MELRemo app and Bluetooth® Low Energy (BLE) technology supports communication with smartphones or tablets in multiple languages



# Interface Devices

## Thermostat Interface



PAC-US444CN-1

- Control your Zoned Comfort Solution using a third-party 24VAC transformer
- Wires back to the indoor unit using CN105 to replace the return air temperature sensor
- Maximum wiring length: 39" (12 m)
- Dimensions: 3.17 in (w) x 3.96 in (h) x 0.93in (d) (80.6 x 100.6 x 23.7 mm)
- Exterior shell made of ABS resin
- Environment Conditions — operating temperature range: Installation manual states that the temperature should be between 32° F and 104° F (0° C to 40° C)

## BACnet® Interface



PAC-UKPRC001-CN-1

- Allows for third-party home automation/building management system to control indoor unit
- One interface required per indoor unit
- Compatible with remote controllers
- Dimensions: 3.74" x 2" x 0.75"
- Cable length: 37"
- Allows for third-party home automation/building management system to control indoor unit

## USNAP Interface



PAC-WHS01UP-E

- Allows indoor units to participate in demand response events
- Works with CTA 2045 DC Form Factor Universal Communication Modules (UCMs)
- 3 LEDs to display device status
- Communication with UCM
- Communication to indoor unit
- Demand Response Events
- System Reset

## MAC-334IF-E System Control Interface



MAC-334IF-E

- Allows M-Series indoor units to communicate with the CITY MULTI® Controls Network via M-Net
- Provides an input to allow remote On/Off control of indoor unit
- Allows M-Series indoor units to connect to MHK2 Wall-Mounted Wireless Controller when using other MAC-334IF-E functions
- Allows M-Series indoor units to connect to a MA controller
- Power: 12V DC (supplied from indoor unit)

# Features

Category	Icon	M-Series																			
		Combination	Indoor Unit	MSZ-FS06/09/12/15/18NA						MSZ-EF09/12/15/18NA(W)(B)(S)						MSZ-GL06/09/12/15/18/24NA					
			Outdoor Unit	MUZ-FS	MXZ-2C	MXZ-3C	MXZ-4C	MXZ-5C	MXZ-8C	MXZ-2C	MXZ-3C	MXZ-4C	MXZ-5C	MXZ-8C	MUZ-GL	MXZ-2C	MXZ-3C	MXZ-4C	MXZ-5C	MXZ-8C	
i-see Sensor	Radiant Temperature Control (3D i-see Sensor®)		•	•	•	•	•	•													
	AREA Temperature Monitor		•	•	•	•	•	•													
Energy Saving	Econo Cool		•	•	•	•	•	•	•	•	•	•	•	•	•	•	•	•	•	•	
Air Quality	Nano Platinum Filter		•	•	•	•	•	•	•	•	•	•	•	•	•	•	•	•	•	•	
	Catechin Filter																				
	Air Cleaning Filter																				
	Deodorizing Filter		•	•	•	•	•	•													
	Electrostatic Anti-Allergy Enzyme Filter		•	•	•	•	•	•	•	•	•	•	•	•	24	24	24	24	24	24	
	Anti-Allergy Enzyme Filter														06-18	06-18	06-18	06-18	06-18	06-18	
	Air Purifying Filter																				
Air Distribution	Double Vane		•	•	•	•	•	•													
	Horizontal Vane		•	•	•	•	•	•	•	•	•	•	•	•	•	•	•	•	•	•	
	Vertical Vane		•	•	•	•	•	•							18/24	18/24	18/24	18/24	18/24	18/24	
	Natural Flow Operation		•	•	•	•	•	•													
	Wide Airflow														24	24	24	24	24	24	
	Indirect/Direct Airflow		•	•	•	•	•	•													
	Powerful Operation		•	•	•	•	•	•							24	24	24	24	24	24	
Convenience	Smart Set		•	•	•	•	•	•	•	•	•	•	•	•	06-18	06-18	06-15	06-18	06-18	06-18	
	Auto Restart		•	•	•	•	•	•	•	•	•	•	•	•	•	•	•	•	•	•	
	Low Temperature Cooling		•	•	•	•	•	•	•	•	•	•	•	•	•	•	•	•	•	•	
	Sleep Mode																				
	12H On/Off Operation Timer																				
	24H On/Off Operation Timer		•	•	•	•	•	•	•	•	•	•	•	•	•	•	•	•	•	•	
	Weekly Timer		•	•	•	•	•	•	•	•	•	•	•	•							
Maintenance	Blue Fin		•			• *1	• *1	•				• *1	• *1	•	•			• *1	• *1	•	
	Dual Barrier Coating		•																		

\*1 Branch box units only: MXZ-8C48NA2, MXZ-8C60NA2, MXZ-4C36HNNH2, MXZ-5C42HNNH2, and MXZ-8C48HNNH2

\*2 Sea coast protection models only (-BS)

	M-Series																								
	MSZ-D 30/ 36NA	MSZ-HM 09/12/15/ 18/24NA	MSY-GL 09/12/15/ 18/24NA	MSY-D 30/ 36NA	MSZ-WR 09/12/ 18/24NA	MSZ-JP 09/ 12WA	MFZ-KJ09/12/15/18NA						MLZ-KP09/12/18NA					SVZ-KP12/18/24/30/36NA							
	MUZ-D	MUZ-HM	MUY-GL	MUY-D	MUZ-WR	MUZ-JP	MUFZ-KJ	MXZ-2C	MXZ-3C	MXZ-4C	MXZ-5C	MXZ-8C	SUZ-KA	MXZ-2C	MXZ-3C	MXZ-4C	MXZ-5C	MXZ-8C	SUZ-KA	MXZ-2C	MXZ-3C	MXZ-4C	MXZ-5C	MXZ-8C	
	•	•	•	•	•	•	•	•	•	•	•	•	•	•	•	•	•	•							
			•		•	•	•	•	•	•	•														
	•			•																					
		•																		•	•	•	•	•	•
			24																						
	•	Opt	09-18	•			Opt	Opt	Opt	Opt	Opt	Opt	Opt	Opt	Opt	Opt	Opt	Opt							
													•	•	•	•	•	•							
	•	•	•	•	•	•	•	•	•	•	•	•	•	•	•	•	•	•							
	•	18/24		•									•	•	•	•	•	•							
	•	24	•																						
	•	24	•	18/24			•	•	•	•	•	•													
		06-18					•	•	•	•	•	•	•	•	•	•	•	•							
	•	•	•	•	•	•	•	•	•	•	•	•	•	•	•	•	•	•	•	•	•	•	•	•	
	•	•	•	•			•	•	•	•	•	•	•	•	•	•	•	•	•	•	•	•	•	•	
		•					•	•	•	•	•	•	•	•	•	•	•	•							
	•		•	•	•	•	•	•	•	•	•	•	•	•	•	•	•	•							
							•	•	•	•	•	•	•	•	•	•	•	•							
		•	•		•	•	•			• *1	• *1	•	•				• *1	• *1	•	•			• *1	• *1	•

Opt: Separate parts must be purchased.

# Features

Category	Icon	Combination	Indoor unit	M-Series												P-Series									
				SLZ-KF09/12/15/18NA						SEZ-KD09/12/15/18NA						PLA-A12/18/24/30/36/42EA7									
				Outdoor Unit	SUZ-KA	MXZ-2C	MXZ-3C	MXZ-4C	MXZ-5C	MXZ-8C	SUZ-KA	MXZ-2C	MXZ-3C	MXZ-4C	MXZ-5C	MXZ-8C	PUZ-A	PUY-A	PUZ-HA	MXZ-3C	MXZ-4C	MXZ-5C	MXZ-8C		
Functions	i-see Sensor	Radiant Temperature Control (3D i-see Sensor®)															•	•	•	•	•	•	•		
		AREA Temperature Monitor																•	•	•	•	•	•	•	
	Energy Saving	ENERGY STAR®																12/18/24/36	12/18/24/36	30/36					
		Demand Function (PAR-33MAA)																•	•	•					
	Air Quality	Fresh-air Intake	•	•	•	•	•	•										•	•	•	•	•	•	•	
		High-efficiency Filter																							
		Long-life Filter	•	•	•	•	•	•										•	•	•	•	•	•	•	
		Filter Check Signal	•	•	•	•	•	•										•	•	•	•	•	•	•	
	Air Distribution	Vertical Swing	•	•	•	•	•	•										•	•	•	•	•	•	•	
		Horizontal Swing																							
		High Ceiling Mode	•	•	•	•	•	•										•	•	•	•	•	•	•	
		Low Ceiling Mode																•	•	•	•	•	•	•	
		Auto Fan Speed Mode	•	•	•	•	•	•	•	•	•	•	•	•	•	•	•	•	•	•	•	•	•	•	
	Convenience	Auto Restart	•	•	•	•	•	•	•	•	•	•	•	•	•	•	•	•	•	•	•	•	•	•	
		Low Temperature Cooling	•	•	•	•	•	•	•	•	•	•	•	•	•	•	•	•	•	•	•	•	•	•	
		12H On/Off Operation Timer																							
		24H On/Off Operation Timer																							
		Weekly Timer																							
	Maintenance	Self-Diagnostic Function	•	•	•	•	•	•	•	•	•	•	•	•	•	•	•	•	•	•	•	•	•	•	
		Failure Recall Function	•	•	•	•	•	•	•	•	•	•	•	•	•	•	•	•	•	•	•	•	•	•	
Blue Fin		•			• *1	• *1	•	•				• *1	• *1	•	• *2	• *2				• *1	• *1	•			

\*1 Branch box units only: MXZ-8C48NA2, MXZ-8C60NA2, MXZ-4C36HNNH2, MXZ-5C42HNNH2, and MXZ-8C48HNNH2

\*2 Sea coast protection models only (-BS)

P-Series																				
PKA-A12/18HA7 PKA-A24/30/36KA7			PCA-A24/30/36/42KA7							PEAD-A12/18/24/30/36/42AA7								PVA-A12/18/24/ 30/36/42AA7		
PUZ-A	PUY-A	PUZ-HA	PUZ-A	PUY-A	PUZ-HA	MXZ-3C	MXZ-4C	MXZ-5C	PUZ-A	PUY-A	PUZ-HA	MXZ-2C	MXZ-3C	MXZ-4C	MXZ-5C	MXZ-8C	PUZ-A	PUY-A	PUZ-HA	
			Opt	Opt	Opt	Opt	Opt	Opt												
									12	12	30/36						12	12	30/36	
•	•	•	•	•	•				•	•	•						•	•	•	
			•	•	•	•	•	•												
			Opt	Opt	Opt	Opt	Opt	Opt												
			•	•	•	•	•	•	•	•	•	•	•	•	•	•				
Opt	Opt	Opt	•	•	•	•	•	•	•	•	•	•	•	•	•	•				
•	•	•	•	•	•	•	•	•												
•	•	•	•	•	•	•	•	•	•	•	•	•	•	•	•	•	•	•	•	•
•	•	•	•	•	•	•	•	•	•	•	•	•	•	•	•	•	•	•	•	•
•	•	•	•	•	•	•	•	•	•	•	•	•	•	•	•	•	•	•	•	•
•	•	•	•	•	•	•	•	•	•	•	•	•	•	•	•	•	•	•	•	•
•	•	•	•	•	•	•	•	•	•	•	•	•	•	•	•	•	•	•	•	•
• *2	• *2		• *2	• *2				• *1	• *1	• *2	• *2				• *1	• *1	•	• *2	• *2	

Opt: Separate parts must be purchased.



## M-Series

Whether for a cold spot or hot spot or the entire home, our systems are versatile and perfectly suited for any cooling or heating occasion.

# M-Series Product Lineup

## Heat Pumps

A multiple model lineup to choose from, each with various outstanding features. In addition to inverter-equipped wall-mounted models, floor-standing and multi-position air handlers can be selected. Choose the best style to match usage needs.

### Wall-Mounted Units



MSZ-FS Model 



MSZ-EF Model



MSZ-GL Model



MSZ-D Model



MSZ-HM Model  
MSZ-JP Model



MSZ-WR Model

### EZ FIT® Ceiling Cassette Unit



MLZ Model 

### Multi-Position Air Handler



SVZ Model 

### Floor-Mounted Unit



MFZ Model 

### Ceiling Cassette Units



SLZ Model 

### Horizontal-ducted Units



SEZ Model 



PEAD Model 

## Cooling Only

For applications with needs for only cooling, there are cooling-only models to choose from.

### Wall-Mounted Units



MSY-D Model



MSY-GL Model



# MSZ-FS Model

Deluxe Wall Mount



## Dual Barrier Coating

The patented Mitsubishi Electric Dual Barrier Coating prevents dust and dirt from accumulating on the inner surface of the heat pump, keeping your heat pump clean year-round.

Blended fluorine particles prevent hydrophilic dirt penetration, and hydrophobic particles prevent hydrophobic dirt from getting into the heat pump. As a result, the patented Dual Barrier Coating keeps the heat exchanger, vanes/air ducts and blower wheel clean.

A clean heat exchanger preserves high-efficiency operation and optimal heat transfer. Also eliminated is additional motor power input required to deliver the proper airflow through a dirty blower wheel and heat exchanger contributing to operational efficiency. Over time, the end result is 30% better airflow and 18% less energy consumption than a system without Dual Barrier Coating.

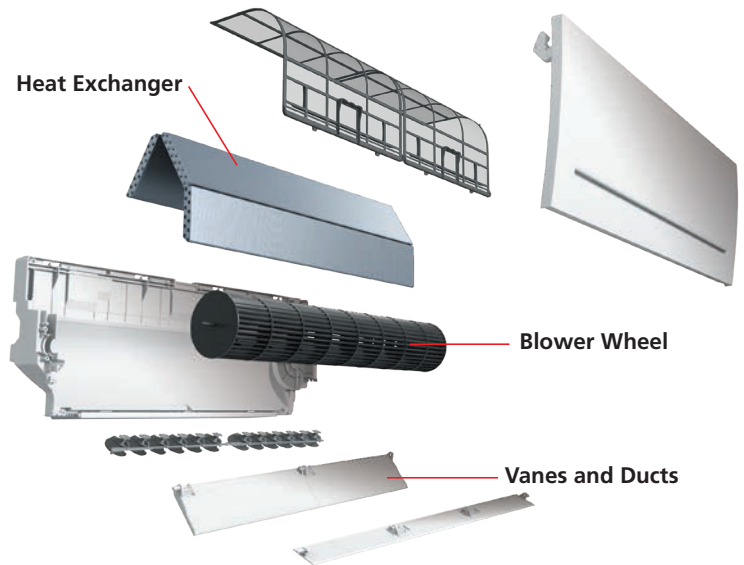

## Comparison of Dirt on Heat Exchanger, Blower Wheel and Air Duct

Actual images of accelerated 10 year test



No Dual Barrier Coating



Dual Barrier Coating Used



# 3D i-see Sensor

The FS Model comes equipped with a 3D i-see Sensor®, an infrared-ray sensor that measures temperatures at different positions throughout the space. While scanning the area from left to right, eight vertically arranged sensor elements analyze the room temperature in three dimensions. Based on temperature readings, the sensor detects the location of people in the room. This technology enables the user to personalize comfort by selecting their preferred airflow setting.

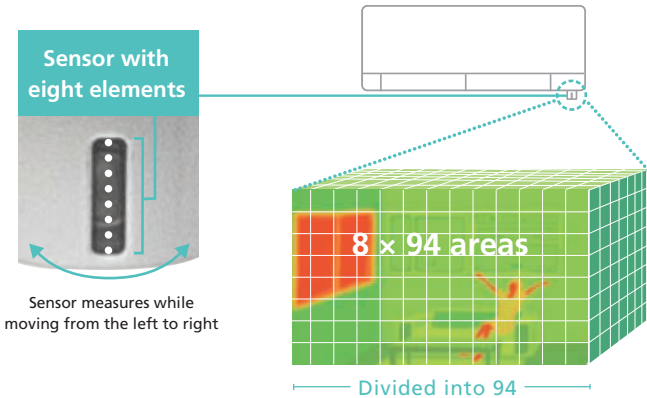

## Indirect Airflow

The Indirect Airflow setting diverts airflow away from people within the space.



## Direct Airflow

The Direct Airflow setting blows conditioned air toward people within the space.



## Absence Detection

The sensors detect whether there are people in the room. When no one is in the area, the unit automatically switches to Energy Saving Mode.



When the 3D i-see Sensor detects an unoccupied room, the power consumption reduces by ~10% after 10 minutes and further decreases by ~20% after 60 minutes.

## Natural Flow

The most critical aspect of comfortable airflow is that it feels natural. The Natural Flow feature is accomplished by alternately oscillating the two vanes to simulate a light breeze.

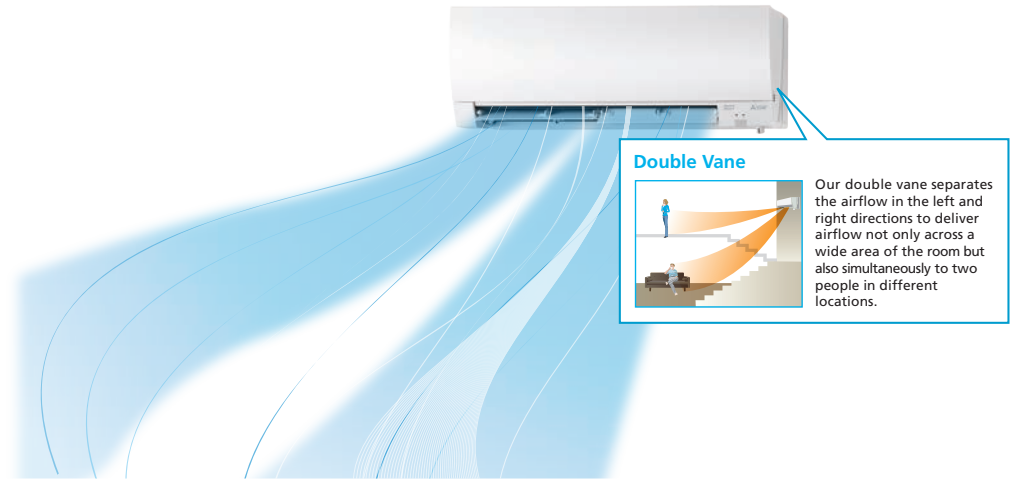
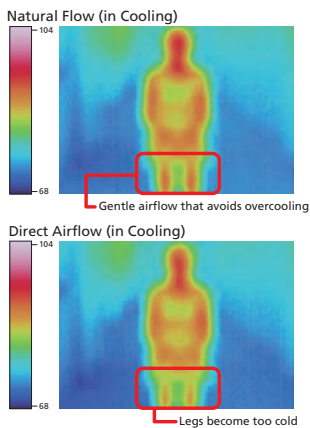

## Base Data for Natural Flow



Kirigamine Highland is one of the most famous sightseeing spots in Japan. A large number of people visit to experience its pleasant breezes and comfortable weather. We attempted to recreate the feeling of the Kirigamine Highland's natural airflow. Engineers collected data at the site and were able to imitate the waveforms.

## Analysis of natural wind

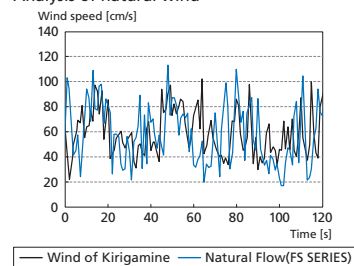

## Deluxe Hand-Held Wireless Controller with Advanced Features

- Backlit display for night time visibility
- Modes identified by text: AUTO, HEAT, COOL, DRY, FAN
- Powerful Mode function allows the system to temporarily run at a lower or higher temperature with an increased fan speed to quickly bring the room to your optimal comfort level
- Wide Vane setting provides a wider horizontal air distribution on select models
- 3D i-see Sensor® control for absence detection and direct/indirect modes for personalized comfort
- Adjustable fan speeds and individual vane control for personalized airflow preference
- Indirect/Direct
- Natural Flow
- Weekly scheduling timer



## Triple-action Filtration

Air, like water, is something we use every day unconsciously. Yet, clean, fresh air is a vital part of creating a healthy space for humans. Healthy air is achieved with three filters: the Nano Platinum filter, the Deodorizing filter, and the Electrostatic anti-allergy enzyme filter.

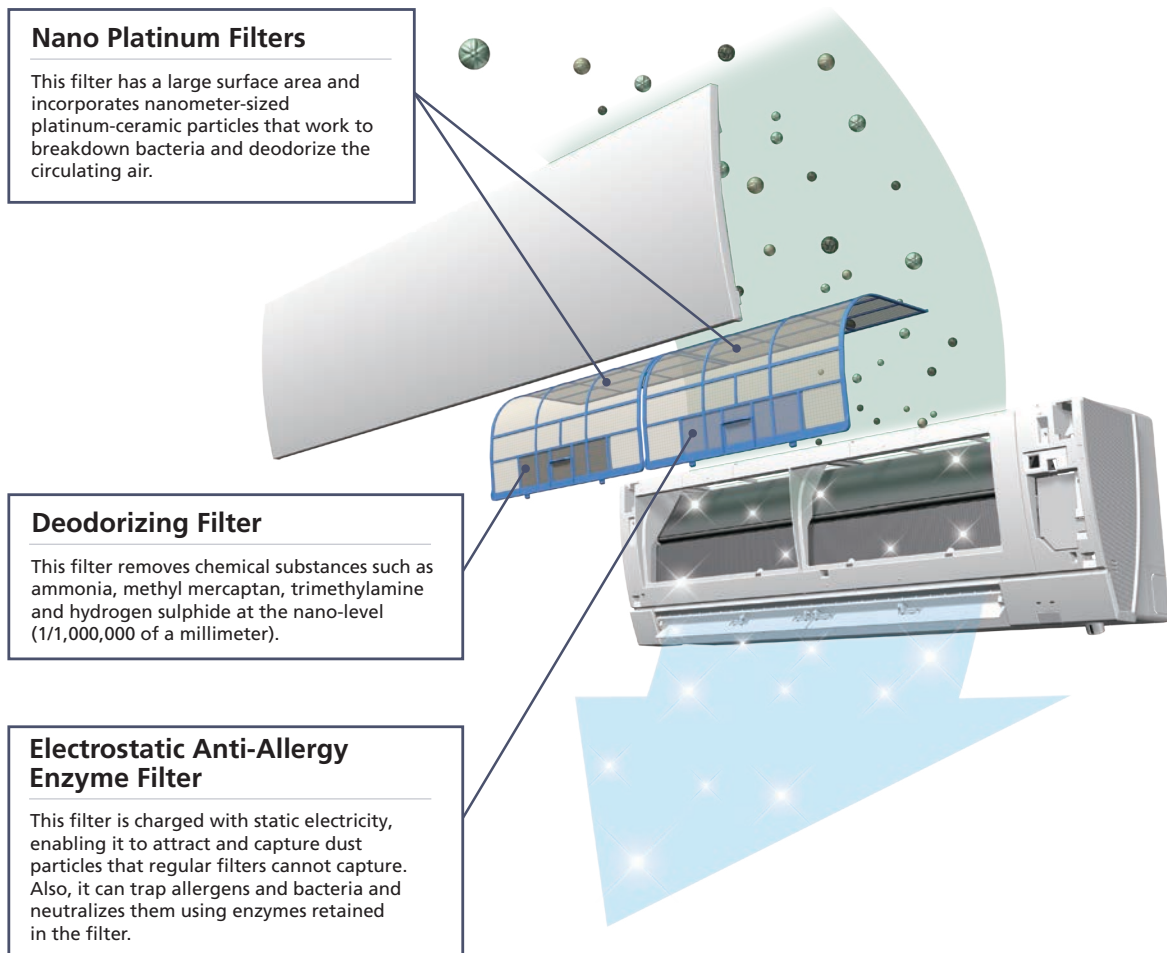

## Quiet Operation

The indoor unit noise level is as low as 20dB(A) for FS06/09 models, offering a peaceful inside environment.

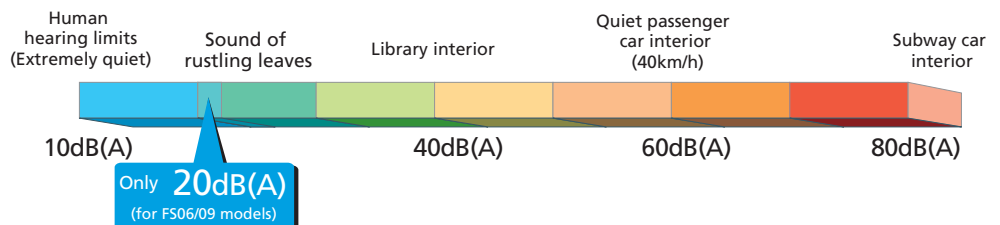

## H2i plus™ Hyper-Heating Performance

H2i plus™ hyper-heating heat pump technology is leading technology in the industry. The H2i plus outdoor units produce up to 100% heating capacity down to -5° F.



### Heating Capacity

	FS06	FS09	FS12	FS15	FS18
Maximum Heating Capacity at 5°F (-15°C)	10,500BTU/H	11,590BTU/H	14,690BTU/H	19,360BTU/H	23,000BTU/H
COP at 5°F (-15°C)	2.46	2.41	2.42	2.17	2.15
Maximum Heating Capacity at -5°F (-20.5°C)	8,700BTU/H	9,600BTU/H	12,300BTU/H	16,000BTU/H	19,000BTU/H
COP at -5°F (-20.5°C)	2.26	2.20	2.24	2.01	2.00

### Industry Leading Performance

Operation guaranteed at minus -13° F,  
100% heating capacity at -5° F

Heating Capacity At Low Temperatures

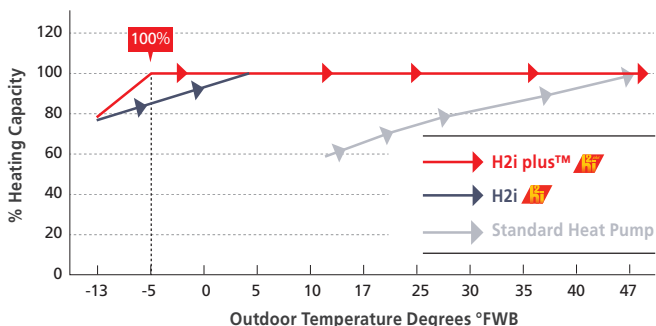

### Base Heater equipped as standard\*

The base heater restricts lowered capacity and operation shutdowns caused by the drain water freezing. This feature supports stable operation in low-temperature environments.



Without Base Heater

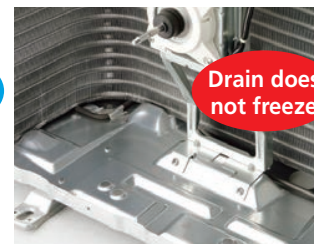

With Base Heater

\*Standard for MUZ-FSxxNAH models  
Optional for MUZ-FSxxNA models

 SEER  HSPF

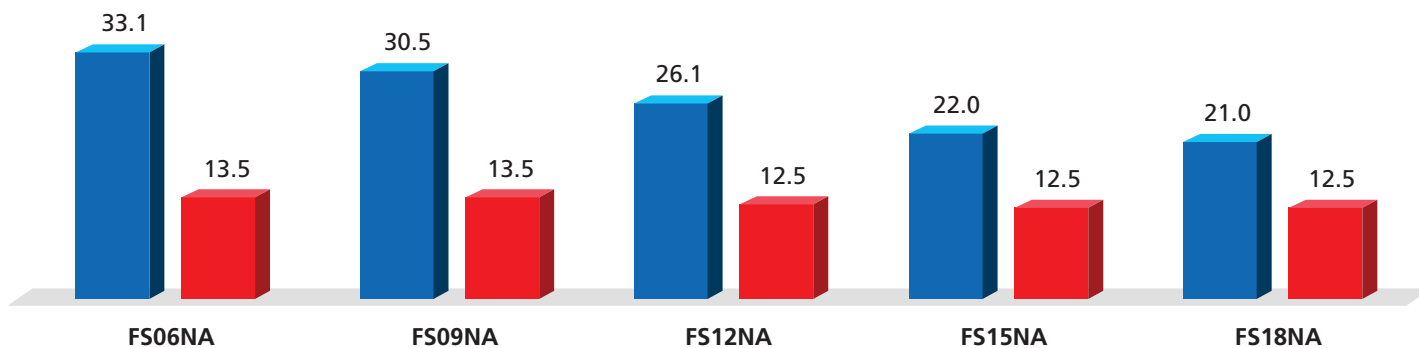

All MSZ-FS single-zone systems are ENERGY STAR® certified.

# MSZ-FS Model

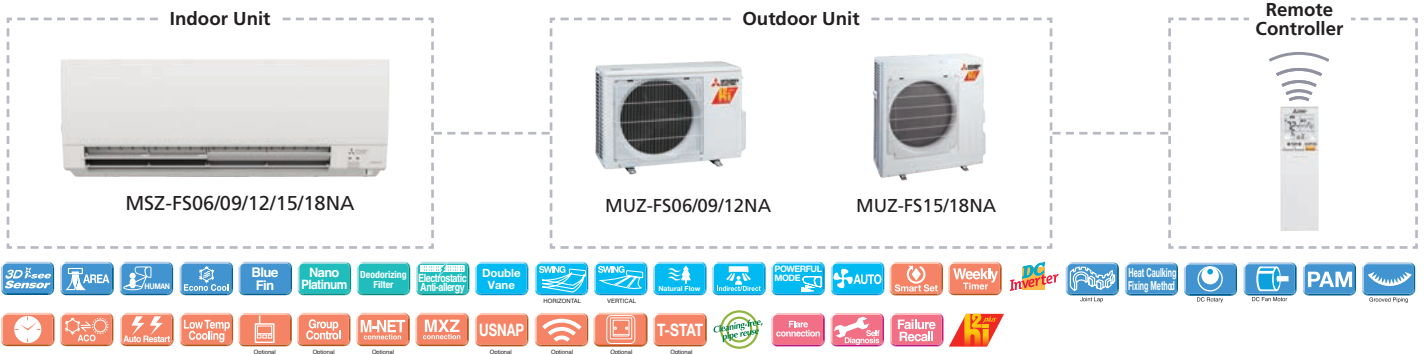

\* To confirm compatibility with the MXZ Model multi-zone system, refer to MXZ Model page.

Indoor Unit				MSZ-FS06NA	MSZ-FS09NA	MSZ-FS12NA	MSZ-FS15NA	MSZ-FS18NA	
Outdoor Unit				MUZ-FS06NA	MUZ-FS09NA	MUZ-FS12NA	MUZ-FS15NA	MUZ-FS18NA	
Cooling	Capacity	Rated <sup>1</sup>	BTU/H	6,000	9,000	12,000	14,000	17,200	
	Capacity Range	Min-Max	BTU/H	1,700-9,000	1,700-12,000	2,500-13,600	6,450-19,000	6,450-21,000	
	Power Input	Rated <sup>1</sup>	W	315	560	870	1,000	1,375	
	Moisture Removal	Pints/h		0.2	0.6	1.9	4.0	4.8	
	Sensible Heat Factor			0.960	0.920	0.830	0.700	0.690	
Heating	Capacity at 47°F	Rated <sup>2</sup>	BTU/H	8,700	9,600	12,300	16,000	19,000	
	Capacity Range	Min-Max	BTU/H	1,600-14,000	1,600-18,000	3,700-21,000	5,150-24,000	5,150-30,000	
	Power Input at 47°F	Rated <sup>2</sup>	W	545	620	850	1,155	1,610	
	Capacity at 17°F	Rated <sup>3</sup>	BTU/H	5,900	5,900	8,400	10,000	12,800	
		Max	BTU/H	12,840	14,170	17,410	22,730	27,000	
	Capacity at 5°F	Max <sup>4</sup>	BTU/H	10,500	11,590	14,690	19,360	23,000	
	Capacity at -5°F	Max <sup>5</sup>	BTU/H	8,700	9,600	12,300	16,000	19,000	
Efficiency	SEER			33.1	30.5	26.1	22.2	21.0	
	EER			19.05	16.05	13.8	14.0	12.5	
	HSPF			13.5	13.5	12.5	12.5	12.5	
	COP			4.68	4.54	4.24	4.06	3.46	
	ENERGY STAR® Certified			Yes	Yes	Yes	Yes	Yes	
Indoor Unit	Air Flow Rate - Cooling (Quiet-Lo-Med-Hi-SHi)	Dry	CFM	137-167-221-304-381	137-167-221-304-381	137-167-221-304-424	225-262-304-355-437	225-262-304-355-437	
		Wet	CFM	117-143-190-261-328	117-143-190-261-328	117-143-190-261-364	194-225-261-305-376	194-225-261-305-376	
	Air Flow Rate - Heating (Quiet-Lo-Med-Hi-SHi)	Dry	CFM	140-167-225-325-437	140-167-225-325-437	155-226-282-367-454	201-272-350-410-514	201-272-350-410-514	
	Sound Pressure Level (Quiet-Lo-Med-Hi-SHi)	Cooling	dB(A)	20-23-29-36-40	20-23-29-36-40	21-24-29-36-44	27-31-35-39-44	27-31-35-39-44	
		Heating	dB(A)	20-24-29-39-42	20-24-29-39-42	21-28-32-38-43	25-31-37-40-46	25-31-37-40-46	
	External Static Pressure		In. W.G.	—	—	—	—	—	
	Condensate Lift Mechanism	Max Distance	In. [mm]		—	—	—	—	—
			H	In. [mm]	12 (+11/16) [305 (+17)]	12 (+11/16) [305 (+17)]	12 (+11/16) [305 (+17)]	12 (+11/16) [305 (+17)]	12 (+11/16) [305 (+17)]
		Dimensions	W	In. [mm]	36-7/16 [925]	36-7/16 [925]	36-7/16 [925]	36-7/16 [925]	36-7/16 [925]
			D	In. [mm]	9-3/16 [234]	9-3/16 [234]	9-3/16 [234]	9-3/16 [234]	9-3/16 [234]
Weight	lbs [kg]		29 [13.5]	29 [13.5]	29 [13.5]	29 [13.5]	29 [13.5]		
Outdoor Unit	MCA	A		10.0	10.0	10.0	18.0	18.0	
	MOCP	A		15	15	15	20	20	
		H	In. [mm]	21-5/8 [550]	21-5/8 [550]	21-5/8 [550]	34-5/8 [880]	34-5/8 [880]	
	Dimensions	W	In. [mm]	31-1/2 [800]	31-1/2 [800]	31-1/2 [800]	33-1/16 [840]	33-1/16 [840]	
		D	In. [mm]	11-1/4 [285]	11-1/4 [285]	11-1/4 [285]	13 [330]	13 [330]	
	Weight	lbs [kg]		82 [37]	82 [37]	83 [37.5]	117 [53]	118 [53.5]	
	Air Flow Rate (Cooling/Heating)	CFM		1141/1183	1141/1183	1215/1201	1801/1949	1801/1949	
	Sound Pressure Level	Cooling	dB(A)	47	48	49	51	52	
Heating		dB(A)	49	49	51	55	55		
Piping	Diameter	Gas (O.D.)	In. [mm]	3/8 [9.52]	3/8 [9.52]	3/8 [9.52]	1/2 [12.7]	1/2 [12.7]	
		Liquid (O.D)	In. [mm]	1/4 [6.35]	1/4 [6.35]	1/4 [6.35]	1/4 [6.35]	1/4 [6.35]	
		Indoor Drain	In. [mm]	5/8 [15.88]	5/8 [15.88]	5/8 [15.88]	5/8 [15.88]	5/8 [15.88]	
Max. Length	ft [m]		65 [20]	65 [20]	65 [20]	100 [30]	100 [30]		
Max. Height	ft [m]		40 [12]	40 [12]	40 [12]	50 [15]	50 [15]		
Electrical	Outdoor-Indoor <sup>6</sup>	V, ph, Hz		208/230, 1, 60	208/230, 1, 60	208/230, 1, 60	208/230, 1, 60	208/230, 1, 60	
	Recommended Breaker Size	A		15	15	15	20	20	
Refrigerant Type				R410A	R410A	R410A	R410A	R410A	
Guaranteed Temperature Operation Range	Cooling <sup>7</sup>	°F DB [°C DB]		14 to 115	14 to 115	14 to 115	14 to 115	14 to 115	
	Heating	°F DB [°C DB]		-13 to 75	-13 to 75	-13 to 75	-13 to 75	-13 to 75	

Notes:  
 AHRI Rated Conditions (Rated data is determined at a fixed compressor speed)  
<sup>1</sup>Cooling (Indoor // Outdoor) °F 80 DB, 67 WB // 95 DB, 75 WB  
<sup>2</sup>Heating at 47°F (Indoor // Outdoor) °F 70 DB, 60 WB // 47 DB, 43 WB  
<sup>3</sup>Heating at 17°F (Indoor // Outdoor) °F 70 DB, 60 WB // 17 DB, 15 WB  
<sup>4</sup>Heating at 5°F (Indoor // Outdoor) °F 70 DB, 60 WB // 5 DB, 4 WB  
<sup>5</sup>Heating at -5°F (Indoor // Outdoor) °F 70 DB, 60 WB // -5 DB, -6 WB  
 Conditions  
<sup>6</sup>Indoor units receive power from outdoor units through field-supplied interconnected wiring.  
<sup>7</sup>Applications should be restricted to comfort cooling only; equipment cooling applications are not recommended for low ambient temperature conditions.

# MSZ-FS (NAH Model)

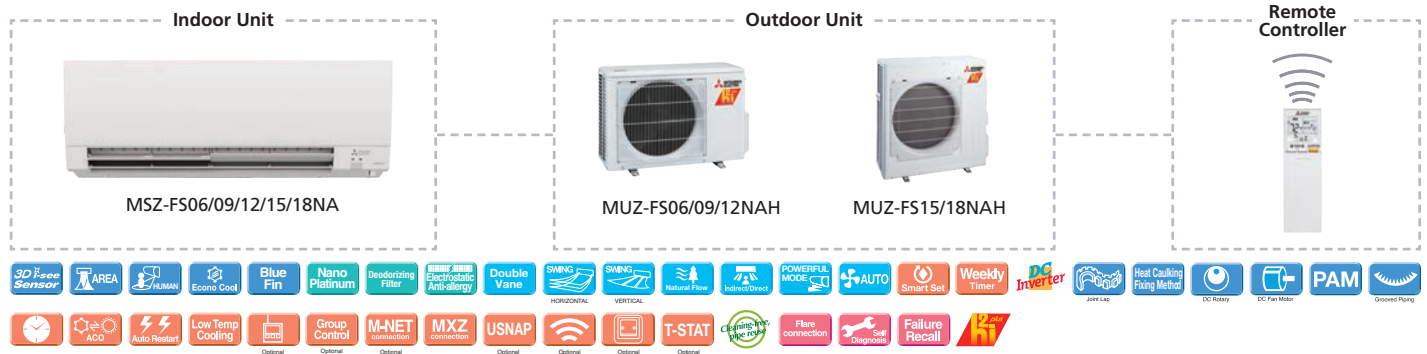

\* To confirm compatibility with the MXZ Model multi-zone system, refer to MXZ Model page.

Indoor Unit			MSZ-FS06NA	MSZ-FS09NA	MSZ-FS12NA	MSZ-FS15NA	MSZ-FS18NA	
Outdoor Unit			MUZ-FS06NAH	MUZ-FS09NAH	MUZ-FS12NAH	MUZ-FS15NAH	MUZ-FS18NAH	
Cooling	Capacity	Rated <sup>1</sup>	BTU/H	6,000	9,000	12,000	14,000	17,200
	Capacity Range	Min-Max	BTU/H	1,700-9,000	1,700-12,000	2,500-13,600	6,450-19,000	6,450-21,000
	Power Input	Rated <sup>1</sup>	W	315	560	870	1,000	1,375
	Moisture Removal	Pints/h		0.2	0.6	1.9	4.0	4.8
	Sensible Heat Factor			0.960	0.920	0.830	0.700	0.690
Heating	Capacity at 47°F	Rated <sup>2</sup>	BTU/H	8,700	9,600	12,300	16,000	19,000
	Capacity Range	Min-Max	BTU/H	1,600-14,000	1,600-18,000	3,700-21,000	5,150-24,000	5,150-30,000
	Power Input at 47°F	Rated <sup>2</sup>	W	545	620	850	1,155	1,610
	Capacity at 17°F	Rated <sup>3</sup>	BTU/H	5,900	5,900	8,400	10,000	12,800
		Max	BTU/H	12,840	14,170	17,410	22,730	27,000
	Capacity at 5°F	Max <sup>4</sup>	BTU/H	10,500	11,590	14,690	19,360	23,000
Efficiency	Capacity at -5°F	Max <sup>5</sup>	BTU/H	8,700	9,600	12,300	16,000	19,000
	SEER			33.1	30.5	26.1	22.2	21.0
	EER			19.05	16.05	13.8	14.0	12.5
	HSPF			12.5	12.5	12.0	12.0	12.0
	COP			4.68	4.54	4.24	4.06	3.46
ENERGY STAR® Certified				Yes	Yes	Yes	Yes	
Indoor Unit	Air Flow Rate - Cooling (Quiet-Lo-Med-Hi-SHi)	Dry	CFM	137-167-221-304-381	137-167-221-304-381	137-167-221-304-424	225-262-304-355-437	225-262-304-355-437
	Air Flow Rate - Cooling (Quiet-Lo-Med-Hi-SHi)	Wet	CFM	117-143-190-261-328	117-143-190-261-328	117-143-190-261-364	194-225-261-305-376	194-225-261-305-376
	Air Flow Rate - Heating (Quiet-Lo-Med-Hi-SHi)	Dry	CFM	140-167-225-325-437	140-167-225-325-437	155-226-282-367-454	201-272-350-410-514	201-272-350-410-514
	Sound Pressure Level (Quiet-Lo-Med-Hi-SHi)	Cooling	dB(A)	20-23-29-36-40	20-23-29-36-40	21-24-29-36-44	27-31-35-39-44	27-31-35-39-44
	Sound Pressure Level (Quiet-Lo-Med-Hi-SHi)	Heating	dB(A)	20-24-29-39-42	20-24-29-39-42	21-28-32-38-43	25-31-37-40-46	25-31-37-40-46
	External Static Pressure		In. W.G.	—	—	—	—	—
	Condensate Lift Mechanism	Max Distance	In. [mm]	—	—	—	—	—
	Dimensions	H	In. [mm]	12 (+11/16) [305 (+17)]	12 (+11/16) [305 (+17)]	12 (+11/16) [305 (+17)]	12 (+11/16) [305 (+17)]	12 (+11/16) [305 (+17)]
		W	In. [mm]	36-7/16 [925]	36-7/16 [925]	36-7/16 [925]	36-7/16 [925]	36-7/16 [925]
		D	In. [mm]	9-3/16 [234]	9-3/16 [234]	9-3/16 [234]	9-3/16 [234]	9-3/16 [234]
Weight		lbs [kg]	29 [13.5]	29 [13.5]	29 [13.5]	29 [13.5]	29 [13.5]	
Outdoor Unit	MCA	A		10.0	10.0	10.0	18.0	18.0
	MOCP	A		15	15	15	20	20
	Dimensions	H	In. [mm]	21-5/8 [550]	21-5/8 [550]	21-5/8 [550]	34-5/8 [880]	34-5/8 [880]
		W	In. [mm]	31-1/2 [800]	31-1/2 [800]	31-1/2 [800]	33-1/16 [840]	33-1/16 [840]
		D	In. [mm]	11-1/4 [285]	11-1/4 [285]	11-1/4 [285]	13 [330]	13 [330]
	Weight		lbs [kg]	83 [37.5]	83 [37.5]	84 [38]	118 [53.5]	118 [53.5]
	Air Flow Rate (Cooling/Heating)		CFM	1141/1183	1141/1183	1215/1201	1801/1949	1801/1949
Sound Pressure Level	Cooling	dB(A)	47	48	49	51	52	
	Heating	dB(A)	49	49	51	55	55	
Piping	Diameter	Gas (O.D.)	In. [mm]	3/8 [9.52]	3/8 [9.52]	3/8 [9.52]	1/2 [12.7]	1/2 [12.7]
		Liquid (O.D)	In. [mm]	1/4 [6.35]	1/4 [6.35]	1/4 [6.35]	1/4 [6.35]	1/4 [6.35]
		Indoor Drain	In. [mm]	5/8 [15.88]	5/8 [15.88]	5/8 [15.88]	5/8 [15.88]	5/8 [15.88]
Max. Length		ft [m]	65 [20]	65 [20]	65 [20]	100 [30]	100 [30]	
Max. Height		ft [m]	40 [12]	40 [12]	40 [12]	50 [15]	50 [15]	
Electrical	Outdoor-Indoor <sup>6</sup>	V, ph, Hz		208/230, 1, 60	208/230, 1, 60	208/230, 1, 60	208/230, 1, 60	208/230, 1, 60
	Recommended Breaker Size	A		15	15	15	20	20
Refrigerant Type				R410A	R410A	R410A	R410A	R410A
Guaranteed Temperature Operation Range	Cooling <sup>7</sup>	°F DB [°C DB]		14 to 115	14 to 115	14 to 115	14 to 115	14 to 115
	Heating	°F DB [°C DB]		-13 to 75	-13 to 75	-13 to 75	-13 to 75	-13 to 75

Notes:  
 AHRI Rated Conditions  
 (Rated data is determined at a fixed compressor speed)

<sup>1</sup>Cooling (Indoor // Outdoor) °F 80 DB, 67 WB // 95 DB, 75 WB  
<sup>2</sup>Heating at 47°F (Indoor // Outdoor) °F 70 DB, 60 WB // 47 DB, 43 WB  
<sup>3</sup>Heating at 17°F (Indoor // Outdoor) °F 70 DB, 60 WB // 17 DB, 15 WB  
<sup>4</sup>Heating at 5°F (Indoor // Outdoor) °F 70 DB, 60 WB // 5 DB, 4 WB  
<sup>5</sup>Heating at -5°F (Indoor // Outdoor) °F 70 DB, 60 WB // -5 DB, -6 WB

Conditions  
<sup>6</sup>Indoor units receive power from outdoor units through field-supplied interconnected wiring.  
<sup>7</sup>Applications should be restricted to comfort cooling only; equipment cooling applications are not recommended for low ambient temperature conditions.



## MSZ-EF Model

Designer Series Wall Mount



### A Stylish Lineup Matches Any Decor

The stylish wall-mounted indoor units have eloquent edges, expressing sophistication and quality. The EF Models come in three color options: matte silver, glossy black, or glossy white.



### Quiet Operation

Our advanced Quiet Mode fan speed setting provides super-quiet operation as low as 21dB(A) for EF09/12 models.

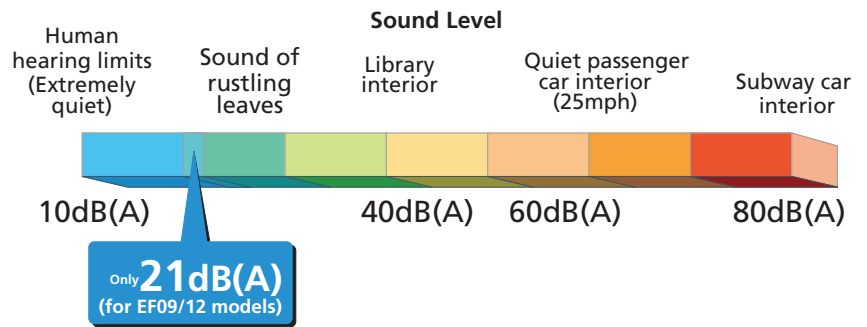

### Superior Design Concept

The EF Model boasts a modern design coupled with advanced technology providing low power consumption, quiet operation, and powerful performance makes these units a smart selection. They maintain their sleek design during operation as the air vane opens and closes, providing the space with comfort.

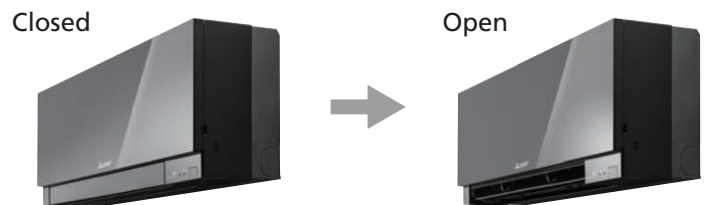

Most MSZ-EF systems are ENERGY STAR® certified.

# MSZ-EF Model

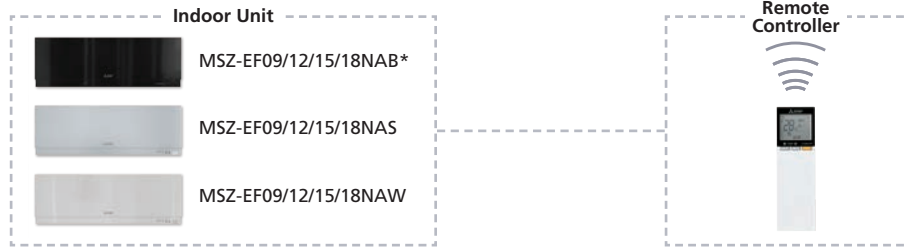

**Color Options Available:**  
**Matte Silver, Glossy Black, or Glossy White**  
 For MXZ Connection Only\*  
 Soft-dry Cloth is enclosed with Black models



Indoor Unit				MSZ-EF09NA(B/S/W)	MSZ-EF12NA(B/S/W)	MSZ-EF15NA(B/S/W)	MSZ-EF18NA(B/S/W)
Cooling	Capacity	Rated <sup>1</sup>	BTU/H	—	—	—	—
	Capacity Range	Min-Max	BTU/H	—	—	—	—
	Power Input	Rated <sup>1</sup>	W	—	—	—	—
	Moisture Removal	Pints/h		—	—	—	—
	Sensible Heat Factor			—	—	—	—
Heating	Capacity at 47°F	Rated <sup>2</sup>	BTU/H	—	—	—	—
	Capacity Range	Min-Max	BTU/H	—	—	—	—
	Power Input at 47°F	Rated <sup>2</sup>	W	—	—	—	—
	Capacity at 17°F	Rated <sup>3</sup>	BTU/H	—	—	—	—
	Capacity at 5°F	Max <sup>4</sup>	BTU/H	—	—	—	—
	Capacity at -5°F	Max <sup>5</sup>	BTU/H	—	—	—	—
Efficiency	SEER			—	—	—	—
	EER			—	—	—	—
	HSPF			—	—	—	—
	COP			—	—	—	—
	ENERGY STAR® Certified			—	—	—	—
Indoor Unit	Air Flow Rate - Cooling (Quiet-Lo-Med-Hi-SHi)	Dry	CFM	141-162-222-293-371	141-162-222-293-371	205-233-272-314-364	205-240-279-328-388
	Air Flow Rate - Cooling (Quiet-Lo-Med-Hi-SHi)	Wet	CFM	121-140-191-252-319	121-140-191-252-319	176-200-234-270-313	176-206-240-282-334
	Air Flow Rate - Heating (Quiet-Lo-Med-Hi-SHi)	Dry	CFM	141-162-219-314-420	141-162-219-314-448	194-222-275-350-448	226-258-318-392-466
	Sound Pressure Level (Quiet-Lo-Med-Hi-SHi)	Cooling	dB(A)	21-23-29-36-42	21-24-29-36-42	28-31-35-39-42	30-33-36-40-43
	Sound Pressure Level (Quiet-Lo-Med-Hi-SHi)	Heating	dB(A)	21-24-29-37-45	21-24-30-38-46	28-30-35-41-48	30-33-37-43-49
	External Static Pressure		In. W.G.	—	—	—	—
	Condensate Lift Mechanism	Max Distance	In. [mm]	—	—	—	—
	Dimensions	H	In. [mm]	11-3/4 [299]	11-3/4 [299]	11-3/4 [299]	11-3/4 [299]
		W	In. [mm]	34-13/16 [884]	34-13/16 [884]	34-13/16 [884]	34-13/16 [884]
		D	In. [mm]	7-11/16 [195]	7-11/16 [195]	7-11/16 [195]	7-11/16 [195]
Weight	lbs [kg]		26 [11.8]	26 [11.8]	26 [11.8]	26 [11.8]	
Outdoor Unit	MCA	A		—	—	—	—
	MOCP	A		—	—	—	—
	Dimensions	H	In. [mm]	—	—	—	—
		W	In. [mm]	—	—	—	—
		D	In. [mm]	—	—	—	—
	Weight	lbs [kg]		—	—	—	—
	Air Flow Rate (Cooling/Heating)	CFM		—	—	—	—
Sound Pressure Level	Cooling	dB(A)	—	—	—	—	
	Heating	dB(A)	—	—	—	—	
Piping	Diameter	Gas (O.D.)	In. [mm]	—	—	—	—
		Liquid (O.D)	In. [mm]	—	—	—	—
		Indoor Drain	In. [mm]	5/8 [15.88]	5/8 [15.88]	5/8 [15.88]	5/8 [15.88]
	Max. Length	ft [m]		—	—	—	—
Max. Height	ft [m]		—	—	—	—	
Electrical	Outdoor-Indoor <sup>6</sup>	V, ph, Hz		—	—	—	—
	Recommended Breaker Size	A		—	—	—	—
Refrigerant Type				—	—	—	—
Guaranteed Temperature Operation Range	Cooling <sup>7</sup>	°F DB [°C DB]		—	—	—	—
	Heating	°F DB [°C DB]		—	—	—	—

Notes:  
 AHRI Rated Conditions (Rated data is determined at a fixed compressor speed)  
<sup>1</sup>Cooling (Indoor // Outdoor) °F 80 DB, 67 WB // 95 DB, 75 WB  
<sup>2</sup>Heating at 47°F (Indoor // Outdoor) °F 70 DB, 60 WB // 47 DB, 43 WB  
<sup>3</sup>Heating at 17°F (Indoor // Outdoor) °F 70 DB, 60 WB // 17 DB, 15 WB  
<sup>4</sup>Heating at 5°F (Indoor // Outdoor) °F 70 DB, 60 WB // 5 DB, 4 WB  
<sup>5</sup>Heating at -5°F (Indoor // Outdoor) °F 70 DB, 60 WB // -5 DB, -6 WB  
 Conditions  
<sup>6</sup>Indoor units receive power from outdoor units through field-supplied interconnected wiring.  
<sup>7</sup>Applications should be restricted to comfort cooling only; equipment cooling applications are not recommended for low ambient temperature conditions.



# MSY/MSZ-GL Model MSY/MSZ-D Model

Standard Wall Mount

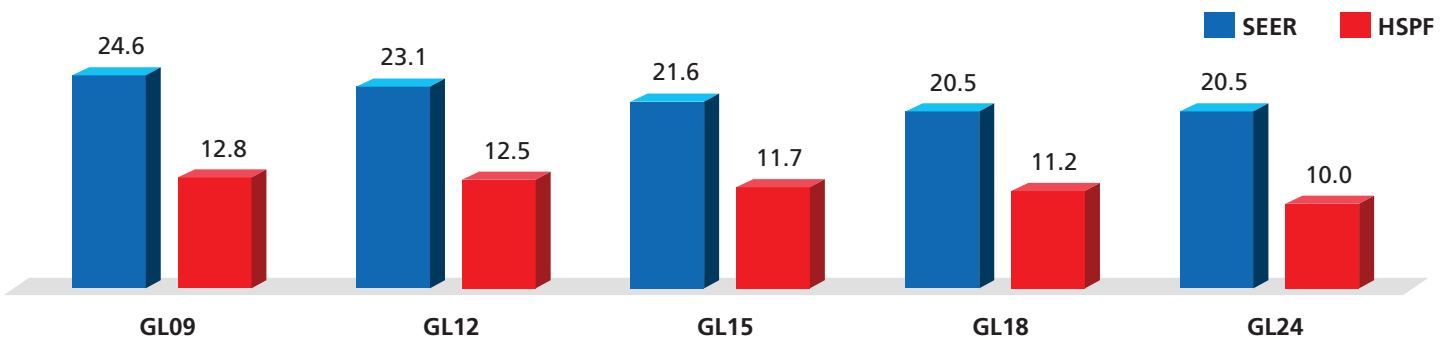

## Large Range of Capacities

The MSY/MSZ-GL and MSY/MSZ-D wall-mounted indoor units offer our highest design flexibility. Combinations include single-zone (cooling only or heat pump) and multi-zone (heat pump or hyper-heating heat pump) systems. A large selection of sizes ranges from 6,000 to 36,000 BTU/H.



MSZ-GL06/09/12/15NA  
MSY-GL09/12/15NA



MSZ/MSY-GL18NA



MSZ/MSY-GL24NA



MSZ/MSY-D30/36NA

## Compact Design

Slim and compact indoor units provide enhanced, industry-leading performance for cooling and heating.



All MSY-GL and MSZ-GL single-zone systems are ENERGY STAR® certified.



## Quiet Operation

The indoor unit noise level is as low as 19dB(A) for GL06/09/12 models, offering a peaceful inside environment.

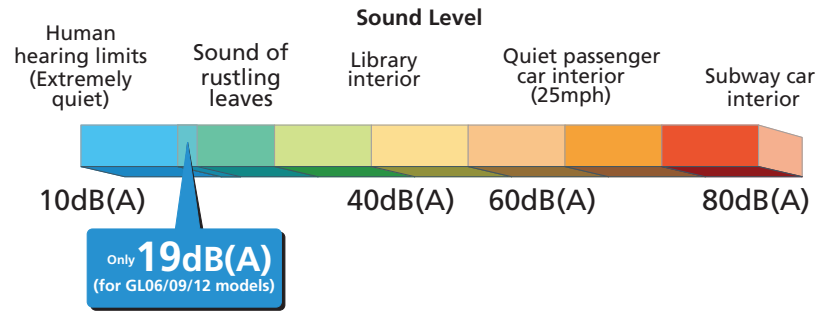

## Powerful Operation (GL24, D30/36)

Depending on the capacity, the unit will automatically adjust the fan speed and set temperature for 15 minutes. Rapid cooling and heating will make the room comfortable quickly.

Fan speed: Exclusive speed for POWERFUL mode.

Horizontal Vane: Set position, or downward airflow position during AUTO setting.

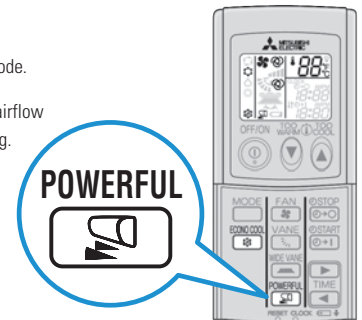

## Nano Platinum Filter (MSZ-GL06, MSZ/MSY-GL09/12/15/18/24)

The Nano Platinum Filter generates stable antibacterial and deodorizing effects. The three-dimensional surface enlarges the filter capture area and increases dust collection performance compared to conventional filters.

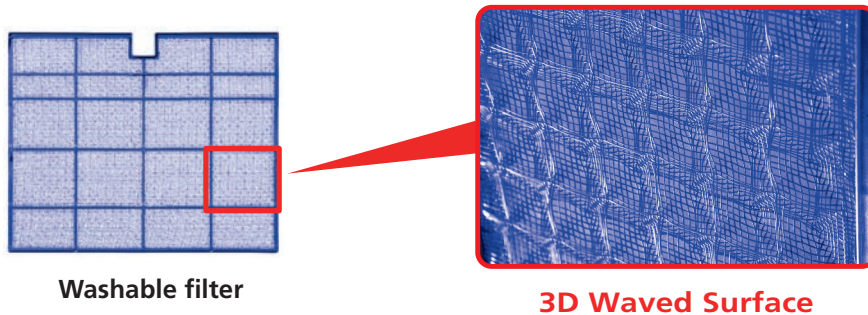

## Smart Set (MSZ-GL06, MSZ/MSY-GL09/12/15/18/24)

Smart Set is a simplified function that recalls the preferred (preset) temperature by pressing a single button on the remote controller. Press the same button twice to return to the previous temperature setting.

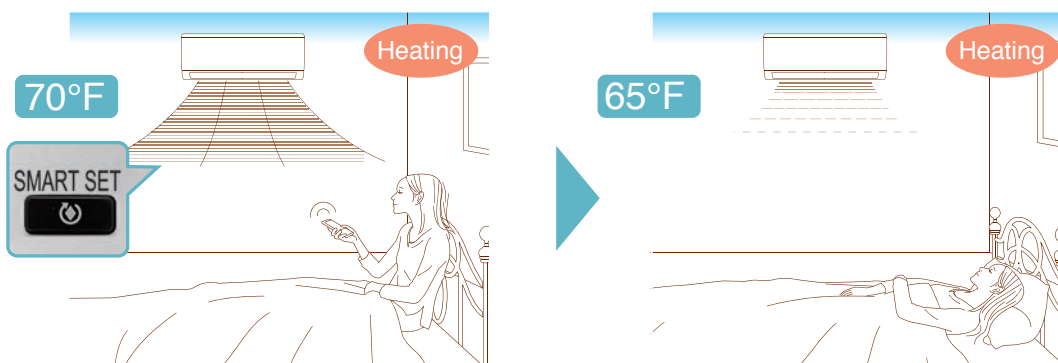

# MSZ/MSY-GL Model

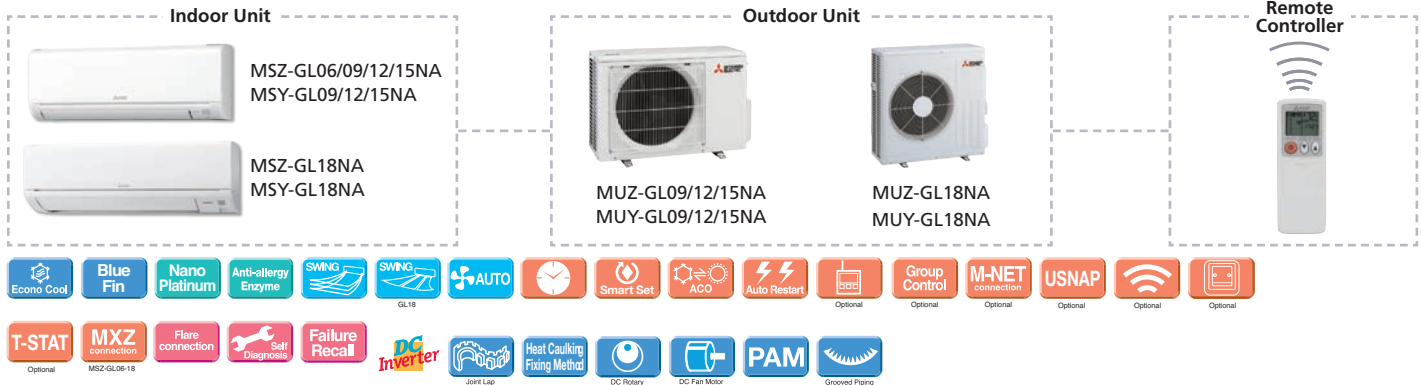

Indoor Unit				MSY-GL09NA	MSY-GL12NA	MSY-GL15NA	MSY-GL18NA	MSY-GL24NA	MSY-D30NA	MSY-D36NA
Outdoor Unit				MUY-GL09NA	MUY-GL12NA	MUY-GL15NA	MUY-GL18NA	MUY-GL24NA	MUY-D30NA	MUY-D36NA
Cooling	Capacity	Rated <sup>1</sup>	BTU/H	9,000	12,000	14,000	18,000	22,500	30,700	34,600
	Capacity Range	Min-Max	BTU/H	3,600-12,200	1,500-13,600	3,100-18,200	5,800-22,000	8,200-31,400	9,800-30,600	9,800-34,600
	Power Input	Rated <sup>1</sup>	W	585	209	1,080	1,340	1,800	3,380	4,249
	Moisture Removal	Pints/h		1.5	2.5	2.7	2.1	5.1	9.9	11.9
	Sensible Heat Factor			0.820	0.770	0.780	0.870	0.750	0.640	0.620
Heating	Capacity at 47°F	Rated	BTU/H	—	—	—	—	—	—	—
	Capacity Range	Min-Max	BTU/H	—	—	—	—	—	—	—
	Power Input at 47°F	Rated	W	—	—	—	—	—	—	—
	Capacity at 17°F	Rated	BTU/H	—	—	—	—	—	—	—
	Capacity at 5°F	Max	BTU/H	—	—	—	—	—	—	—
	Capacity at -5°F	Max	BTU/H	—	—	—	—	—	—	—
Efficiency	SEER			24.6	23.1	21.6	20.5	20.5	16.0	15.1
	EER			15.4	13.0	13.0	13.4	12.5	9.1	8.2
	HSPF			—	—	—	—	—	—	—
	COP			—	—	—	—	—	—	—
	ENERGY STAR® Certified			Yes	Yes	Yes	Yes	Yes	No	No
Indoor Unit	Air Flow Rate - Cooling (Quiet-Lo-Med-Hi-SHi)	Dry	CFM	145-170-237-321-399	145-170-237-321-399	205-272-335-420-533	258-332-417-522-646	388-469-544-628-738	389-639-848-887	389-639-848-887
	Air Flow Rate - Cooling (Quiet-Lo-Med-Hi-SHi)	Wet	CFM	109-134-201-286-364	109-134-201-286-364	170-237-300-385-498	232-299-375-470-581	347-420-487-562-661	350-576-763-798	350-576-763-798
	Air Flow Rate - Heating (Quiet-Lo-Med-Hi-SHi)	Dry	CFM	—	—	—	—	—	—	—
	Sound Pressure Level (Quiet-Lo-Med-Hi-SHi)	Cooling	dB(A)	19-22-30-37-43	19-22-30-37-45	26-32-38-44-49	28-33-38-44-49	34-41-45-49-53	32-42-49-51	32-42-49-51
	Sound Pressure Level (Quiet-Lo-Med-Hi-SHi)	Heating	dB(A)	—	—	—	—	—	—	—
	External Static Pressure		In. W.G.	—	—	—	—	—	—	—
	Condensate Lift Mechanism	Max Distance	In. [mm]	—	—	—	—	—	—	—
	Dimensions	H	In. [mm]	11-5/8 [295]	11-5/8 [295]	11-5/8 [295]	12 [305]	12-13/16 [325]	14-3/8 [365]	14-3/8 [365]
		W	In. [mm]	31-7/16 [798]	31-7/16 [798]	31-7/16 [798]	36-5/16 [923]	43-5/16 [1100]	46-1/16 [1170]	46-1/16 [1170]
		D	In. [mm]	9-1/8 [232]	9-1/8 [232]	9-1/8 [232]	9-13/16 [250]	9-3/8 [238]	11-5/8 [295]	11-5/8 [295]
Weight	lbs [kg]		22 [10.0]	22 [10.0]	22 [10.0]	28 [13.0]	37 [17.0]	40 [18.0]	40 [18.0]	
Outdoor Unit	MCA	A		7.0	7.0	9.0	14.0	17.1	21.0	21.0
	MOCP	A		15	15	15	15	20	25	25
	Dimensions	H	In. [mm]	21-5/8 [550]	21-5/8 [550]	21-5/8 [550]	34-5/8 [880]	34-5/8 [880]	33-7/16 [850]	33-7/16 [850]
		W	In. [mm]	31-1/2 [800]	31-1/2 [800]	31-1/2 [800]	33-1/16 [840]	33-1/16 [840]	33-1/16 [840]	33-1/16 [840]
		D	In. [mm]	11-1/4 [286]	11-1/4 [286]	11-1/4 [286]	13 [330]	13 [330]	13 [330]	13 [330]
	Weight	lbs [kg]		81 [37]	81 [37]	81 [37]	121 [55]	119 [54]	126 [57]	126 [57]
	Air Flow Rate (Cooling/Heating)	CFM		1229/—	1229/—	1243/—	1691/—	1769/—	1941/—	1941/—
	Sound Pressure Level	Cooling	dB(A)	48	49	49	54	55	55	56
		Heating	dB(A)	—	—	—	—	—	—	—
	Piping	Diameter	Gas (O.D.)	In. [mm]	3/8 [9.52]	3/8 [9.52]	1/2 [12.7]	1/2 [12.7]	5/8 [15.88]	5/8 [15.88]
Liquid (O.D.)			In. [mm]	1/4 [6.35]	1/4 [6.35]	1/4 [6.35]	1/4 [6.35]	3/8 [9.52]	3/8 [9.52]	3/8 [9.52]
Indoor Drain			In. [mm]	5/8 [15.88]	5/8 [15.88]	5/8 [15.88]	5/8 [15.88]	5/8 [15.88]	5/8 [15.88]	5/8 [15.88]
Max. Length		ft [m]		65 [20]	65 [20]	65 [20]	100 [30]	100 [30]	100 [30]	
Max. Height		ft [m]		40 [12]	40 [12]	40 [12]	50 [15]	50 [15]	50 [15]	
Electrical	Outdoor-Indoor <sup>5</sup>	V, ph, Hz		208/230, 1, 60	208/230, 1, 60	208/230, 1, 60	208/230, 1, 60	208/230, 1, 60	208/230, 1, 60	208/230, 1, 60
	Recommended Breaker Size	A		15	15	15	15	20	25	25
Refrigerant Type				R410A						
Guaranteed Temperature Operation Range	Cooling <sup>6</sup>	°F DB [°C DB]		14 to 115 [-10.0 to 46.0]	14 to 115 [-10.0 to 46.0]	14 to 115 [-10.0 to 46.0]	14 to 115 [-10.0 to 46.0]	14 to 115 [-10.0 to 46.0]	14 to 115 [-10.0 to 46.0]	14 to 115 [-10.0 to 46.0]
	Heating	°F DB [°C DB]		—	—	—	—	—	—	—

Notes:  
 AHRI Rated Conditions  
 (Rated data is determined at a fixed compressor speed)  
<sup>1</sup>Indoor units receive power from outdoor units through field-supplied interconnected wiring.  
<sup>2</sup>Applications should be restricted to comfort cooling only; equipment cooling applications are not recommended for low ambient temperature conditions.  
<sup>3</sup>Cooling (Indoor // Outdoor)  
<sup>4</sup>°F 80 DB, 67 WB // 95 DB, 75 WB

# MSZ/MSY-GL Model MSZ/MSY-D Model

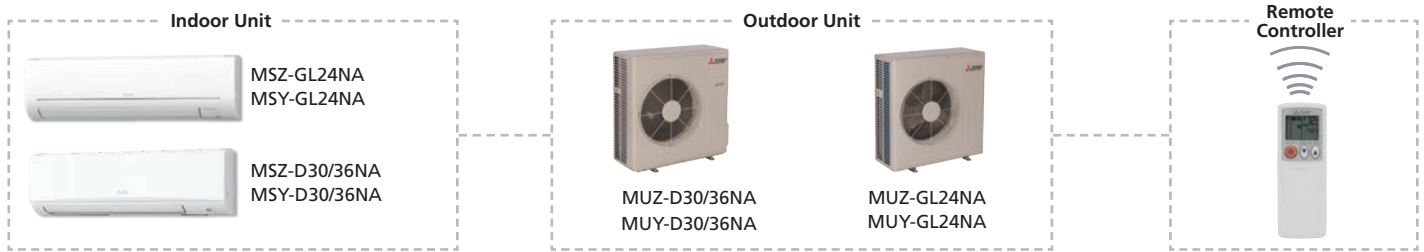

Indoor Unit				MSZ-GL06NA	MSZ-GL09NA	MSZ-GL12NA	MSZ-GL15NA	MSZ-GL18NA	MSZ-GL24NA	MSZ-D30NA	MSZ-D36NA
Outdoor Unit					MUZ-GL09NA	MUZ-GL12NA	MUZ-GL15NA	MUZ-GL18NA	MUZ-GL24NA	MUZ-D30NA	MUZ-D36NA
Cooling	Capacity	Rated <sup>1</sup>	BTU/H	—	9,000	12,000	14,000	18,000	22,400	30,600	33,200
	Capacity Range	Min-Max	BTU/H	—	3,600–12,200	1,500–13,600	3,100–18,200	5,800–22,000	8,200–31,400	9,800–30,700	9,800–33,200
	Power Input	Rated <sup>1</sup>	W	—	585	920	1,080	1,340	1,800	3,850	4,360
	Moisture Removal	Pints/h		—	1.5	2.5	2.7	2.1	5.1	9.9	11.3
	Sensible Heat Factor			—	0.820	0.740	0.800	0.870	0.750	0.640	0.620
Heating	Capacity at 47°F	Rated <sup>2</sup>	BTU/H	—	10,900	14,400	18,000	21,600	27,600	32,600	35,200
	Capacity Range	Min-Max	BTU/H	—	4,500–15,900	2,000–18,100	4,800–20,900	5,400–25,000	7,500–36,900	8,700–34,000	8,700–36,000
	Power Input at 47°F	Rated <sup>2</sup>	W	—	720	1,100	1,600	1,680	2,340	3,360	3,840
	Capacity at 17°F	Rated <sup>3</sup>	BTU/H	—	6,700	9,200	12,200	13,800	16,000	19,500	21,800
		Max	BTU/H	—	10,200	12,000	16,400	18,200	24,600	20,800	22,800
	Capacity at 5°F	Max <sup>4</sup>	BTU/H	—	8,170	9,790	13,680	14,900	19,320	—	—
	Capacity at -5°F	Max <sup>5</sup>	BTU/H	—	—	—	—	—	—	—	—
Efficiency	SEER			—	24.6	23.1	21.6	20.5	20.5	14.5	14.5
	EER			—	15.4	13.0	13.0	13.4	12.5	8.0	7.6
	HSPF			—	12.8	12.5	11.7	11.2	10.0	8.2	8.2
	COP			—	4.44	3.84	3.3	3.77	3.46	2.84	2.69
	ENERGY STAR® Certified			—	Yes	Yes	Yes	Yes	Yes	No	No
Indoor Unit	Air Flow Rate - Cooling (Quiet-Lo-Med-Hi-SHi)	Dry	CFM	145-170-237-321-399	145-170-237-321-399	145-170-237-321-399	205-272-335-420-533	258-332-417-522-646	388-469-544-628-738	389-639-848-887	389-639-848-887
	Air Flow Rate - Cooling (Quiet-Lo-Med-Hi-SHi)	Wet	CFM	109-134-201-286-364	109-134-201-286-364	109-134-201-286-364	170-237-300-385-498	232-299-375-470-581	347-420-487-562-661	350-576-763-798	350-576-763-798
	Air Flow Rate - Heating (Quiet-Lo-Med-Hi-SHi)	Dry	CFM	145-170-237-321-406	145-170-237-321-406	145-170-237-321-406	205-247-304-367-463	297-385-469-565-646	388-469-544-628-738	445-639-848-887	445-639-848-887
	Sound Pressure Level (Quiet-Lo-Med-Hi-SHi)	Cooling	dB(A)	19-22-30-37-43	19-22-30-37-43	19-22-30-37-45	26-32-38-44-49	28-33-38-44-49	34-41-45-49-53	32-42-49-51	32-42-49-51
	Sound Pressure Level (Quiet-Lo-Med-Hi-SHi)	Heating	dB(A)	19-22-30-37-43	19-22-30-37-43	19-22-30-37-43	26-30-35-40-46	28-33-38-43-48	32-41-45-49-52	34-42-49-50	34-42-49-50
	External Static Pressure		In. W.G.	—	—	—	—	—	—	—	—
	Condensate Lift Mechanism	Max Distance	In. [mm]	—	—	—	—	—	—	—	—
	Dimensions	H	In. [mm]	11-5/8 [295]	11-5/8 [295]	11-5/8 [295]	11-5/8 [295]	12 [305]	12-13/16 [325]	14-3/8 [365]	14-3/8 [365]
		W	In. [mm]	31-7/16 [798]	31-7/16 [798]	31-7/16 [798]	31-7/16 [798]	36-5/16 [923]	43-5/16 [1100]	46-1/16 [1170]	46-1/16 [1170]
		D	In. [mm]	9-1/8 [232]	9-1/8 [232]	9-1/8 [232]	9-1/8 [232]	9-13/16 [250]	9-3/8 [238]	11-5/8 [295]	11-5/8 [295]
Weight	lbs [kg]		22 [10.0]	22 [10.0]	22 [10.0]	22 [10.0]	28 [13.0]	37 [17.0]	40 [18.0]	40 [18.0]	
Outdoor Unit	MCA	A		—	9.0	9.0	0.0	14.0	7.0	21.0	21.0
	MOCP	A		—	15	15	15	15	20	25	25
	Dimensions	H	In. [mm]	—	21-5/8 [550]	21-5/8 [550]	21-5/10 [550]	34-5/8 [880]	34-5/8 [550]	33-7/16 [850]	33-7/16 [850]
		W	In. [mm]	—	31-1/2 [800]	31-1/2 [800]	31-1/4 [800]	33-1/16 [840]	33-1/16 [840]	33-1/16 [840]	33-1/16 [840]
		D	In. [mm]	—	11-1/4 [285]	11-1/5 [285]	11-1/6 [285]	13 [330]	13 [330]	13 [330]	13 [330]
	Weight	lbs [kg]		—	81 [37]	81 [37]	81 [37]	121 [55]	119 [54]	126 [57]	126 [57]
	Air Flow Rate (Cooling/Heating)	CFM		—	1229/1172	1229/1172	1243/1129	1691/1691	1769/1701	1941/1941	1941/1941
Sound Pressure Level	Cooling	dB(A)	—	48	49	49	54	55	55	56	
	Heating	dB(A)	—	50	51	51	55	55	57	56	
Piping	Diameter	Gas (O.D.)	In. [mm]	—	3/8 [9.52]	3/8 [9.52]	1/2 [12.7]	1/2 [12.7]	5/8 [15.88]	5/8 [15.88]	5/8 [15.88]
		Liquid (O.D)	In. [mm]	—	1/4 [6.35]	1/4 [6.35]	1/4 [6.35]	1/4 [6.35]	3/8 [9.52]	3/8 [9.52]	3/8 [9.52]
		Indoor Drain	In. [mm]	5/8 [15.88]	5/8 [15.88]	5/8 [15.88]	5/8 [15.88]	5/8 [15.88]	5/8 [15.88]	5/8 [15.88]	5/8 [15.88]
	Max. Length	ft [m]		—	65 [20]	65 [20]	65 [20]	100 [30]	100 [30]	100 [30]	
Max. Height	ft [m]		—	40 [12]	40 [12]	40 [12]	50 [15]	50 [15]	50 [15]	50 [15]	
Electrical	Outdoor-Indoor <sup>6</sup>	V, ph, Hz	—	208/230, 1, 60	208/230, 1, 60	208/230, 1, 60	208/230, 1, 60	208/230, 1, 60	208/230, 1, 60	208/230, 1, 60	208/230, 1, 60
	Recommended Breaker Size	A		—	15	15	15	15	20	25	25
Refrigerant Type				—	R410A	R410A	R410A	R410A	R410A	R410A	R410A
Guaranteed Temperature Operation Range	Cooling <sup>7</sup>	°F DB [°C DB]	—	14 to 115 [-10.0 to 46.0]	14 to 115 [-10.0 to 46.0]	14 to 115 [-10.0 to 46.0]	14 to 115 [-10.0 to 46.0]	14 to 115 [-10.0 to 46.0]	14 to 115 [-10.0 to 46.0]	14 to 115 [-10.0 to 46.0]	14 to 115 [-10.0 to 46.0]
	Heating	°F DB [°C DB]	—	-4 to 75 [-20.0 to 24.0]	-4 to 75 [-20.0 to 24.0]	-4 to 75 [-20.0 to 24.0]	-4 to 75 [-20.0 to 24.0]	-4 to 75 [-20.0 to 24.0]	-4 to 75 [-20.0 to 24.0]	-4 to 75 [-20.0 to 24.0]	-4 to 75 [-20.0 to 24.0]

Notes:  
AHRI Rated Conditions  
(Rated data is determined at a fixed compressor speed)

<sup>1</sup>Cooling (Indoor // Outdoor) °F 80 DB, 67 WB // 95 DB, 75 WB  
<sup>2</sup>Heating at 47°F (Indoor // Outdoor) °F 70 DB, 60 WB // 47 DB, 43 WB  
<sup>3</sup>Heating at 17°F (Indoor // Outdoor) °F 70 DB, 60 WB // 17 DB, 15 WB  
<sup>4</sup>Heating at 5°F (Indoor // Outdoor) °F 70 DB, 60 WB // 5 DB, 4 WB  
<sup>5</sup>Heating at -5°F (Indoor // Outdoor) °F 70 DB, 60 WB // -5 DB, -6 WB

Conditions

<sup>6</sup>Indoor units receive power from outdoor units through field-supplied interconnected wiring.

<sup>7</sup>Applications should be restricted to comfort cooling only; equipment cooling applications are not recommended for low ambient temperature conditions.



# MSZ-HM Model

18 SEER Wall Mount



## Stylish Design

A stylish flat panel design creates a simple look that matches any room aesthetics.



## Econo Cool Energy-Saving Feature

Econo Cool is an intelligent temperature control feature that adjusts the amount of air discharged based on the air-outlet temperature. The temperature set point can be raised up to 4° without any loss in comfort, thereby realizing a 20% gain in energy efficiency. (Function only available during manual cooling operation.)

	Conventional	Econo Cool
Ambient Temperature	95° F	95° F
Set point	77° F	81° F
Perceived Temperature	86° F	85° F

Econo Cool



Conventional Cooling Mode



Temperature distribution (° F)

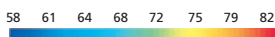

## Quiet Operation

A quiet, relaxing space is within reach. Operational noise is as low as 22dB(A).

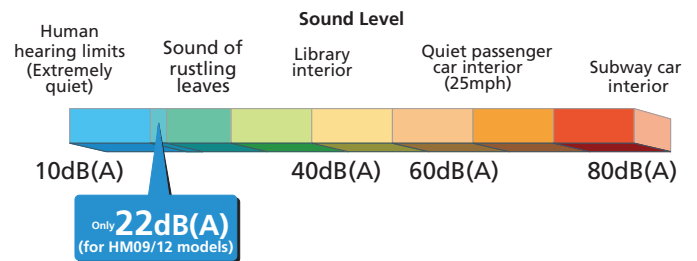

## Air Filter

This filter can remove dust particles from the air.

## Anti-allergy Enzyme Filter\* (\*Optional)

This filter works to trap allergens such as bacteria and decompose them using enzymes retained in the filter.

## 12-hour Timer

Allows for one ON/OFF cycle during a 12-hour period.

## Blue Fin Heat Exchanger

Blue Fin is an anti-corrosion coating applied to the heat exchanger of the outdoor unit. This treatment prevents the deterioration of the aluminum fins caused by salt, especially in coastal areas. (Corrosion of the heat exchanger will affect the efficiency and performance of the outdoor unit.)

# MSZ-HM Model

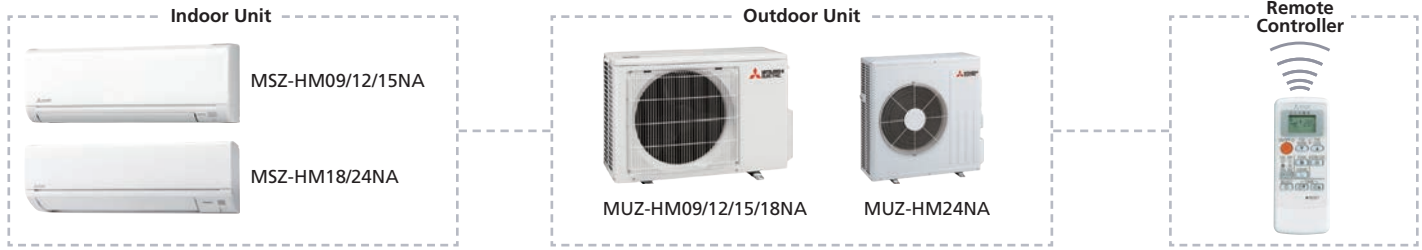

Indoor Unit				MSZ-HM09NA	MSZ-HM12NA	MSZ-HM15NA	MSZ-HM18NA	MSZ-HM24NA
Outdoor Unit				MUZ-HM09NA	MUZ-HM12NA	MUZ-HM15NA	MUZ-HM18NA	MUZ-HM24NA
Cooling	Capacity	Rated <sup>1</sup>	BTU/H	9,000	12,000	14,000	17,200	22,500
	Capacity Range	Min-Max	BTU/H	3,800–10,000	3,800–12,200	3,100–16,000	5,800–18,000	5,800–22,500
	Power Input	Rated <sup>1</sup>	W	750	1,210	1,170	1,640	2,630
	Moisture Removal		Pints/h	1.5	2.5	2.7	2.1	2.3
	Sensible Heat Factor			0.820	0.770	0.780	0.860	0.890
Heating	Capacity at 47°F	Rated <sup>2</sup>	BTU/H	10,900	12,200	18,000	18,000	26,000
	Capacity Range	Min-Max	BTU/H	4,500–11,800	4,500–14,500	4,800–18,500	5,400–20,900	5,400–26,000
	Power Input at 47°F	Rated <sup>2</sup>	W	900	990	1,600	1,590	2,500
	Capacity at 17°F	Rated <sup>3</sup>	BTU/H	6,700	7,600	11,500	11,500	18,500
		Max	BTU/H	7,200	900	14,000	15,000	18,500
	Capacity at 5°F	Max <sup>4</sup>	BTU/H	5,990	9,000	12,240	12,780	15,600
	Capacity at -5°F	Max <sup>5</sup>	BTU/H	—	—	—	—	—
Efficiency	SEER			18.0	18.0	18.0	18.0	18.0
	EER			12.0	9.9	12.0	10.5	8.6
	HSPF			10.0	10.0	10.0	10.0	10.0
	COP			3.55	3.61	3.3	3.32	3.05
	ENERGY STAR® Certified			No	No	No	No	No
Indoor Unit	Air Flow Rate - Cooling (Quiet-Lo-Med-Hi-SHi)	Dry	CFM	170–237–321–399	170–237–321–399	272–335–420–533	328–431–530–625	353–431–530–702
	Air Flow Rate - Cooling (Quiet-Lo-Med-Hi-SHi)	Wet	CFM	134–201–286–364	134–201–286–364	237–300–385–498	295–388–477–562	318–388–477–632
	Air Flow Rate - Heating (Quiet-Lo-Med-Hi-SHi)	Dry	CFM	170–237–321–406	170–237–321–406	247–304–367–463	307–431–530–625	346–448–579–702
	Sound Pressure Level (Quiet-Lo-Med-Hi-SHi)	Cooling	dB(A)	22–30–37–43	22–30–37–45	32–38–44–49	30–37–42–47	33–38–44–50
	Sound Pressure Level (Quiet-Lo-Med-Hi-SHi)	Heating	dB(A)	22–30–37–43	22–30–37–43	30–35–40–46	30–37–42–47	32–38–44–50
	External Static Pressure		In. W.G.	—	—	—	—	—
	Condensate Lift Mechanism	Max Distance	In. [mm]	—	—	—	—	—
	Dimensions	H	In. [mm]	11-5/8 [295]	11-5/8 [295]	11-5/8 [295]	12 [305]	12 [305]
		W	In. [mm]	31-7/16 [798]	31-7/16 [798]	31-7/16 [798]	36-5/16 [923]	36-5/16 [923]
		D	In. [mm]	9-1/8 [232]	9-1/8 [232]	9-1/8 [232]	9-13/16 [250]	9-13/16 [250]
Weight		lbs [kg]	22 [10]	22 [10]	22 [10]	28 [13.0]	28 [13.0]	
	MCA	A	9.0	9.0	10.0	10.0	14.0	
Outdoor Unit	MOCP	A	15	15	15	15	15	
	Dimensions	H	In. [mm]	21-5/8 [550]	21-5/8 [550]	21-5/8 [550]	21-5/8 [550]	34-5/8 [880]
		W	In. [mm]	31-1/2 [800]	31-1/2 [800]	31-1/2 [800]	31-1/2 [800]	33-1/16 [840]
		D	In. [mm]	11-1/4 [286]	11-1/4 [286]	11-1/4 [286]	11-1/4 [286]	13 [330]
	Weight	lbs [kg]	73 [33.1]	73 [33.1]	81 [36.7]	81 [36.7]	121 [55]	
	Air Flow Rate (Cooling/Heating)		CFM	1151/1225	1151/1225	1243/1229	1243/1229	1691/1691
	Sound Pressure Level	Cooling	dB(A)	46	49	49	50	54
Heating		dB(A)	50	51	51	51	55	
Piping	Diameter	Gas (O.D.)	In. [mm]	3/8 [9.52]	3/8 [9.52]	1/2 [12.7]	1/2 [12.7]	5/8 [15.88]
		Liquid (O.D)	In. [mm]	1/4 [6.35]	1/4 [6.35]	1/4 [6.35]	1/4 [6.35]	3/8 [9.52]
		Indoor Drain	In. [mm]	5/8 [15.88]	5/8 [15.88]	5/8 [15.88]	5/8 [15.88]	5/8 [15.88]
Max. Length	ft [m]	65 [20]	65 [20]	65 [20]	65 [20]	100 [30]		
Max. Height	ft [m]	40 [12]	40 [12]	40 [12]	40 [12]	50 [15]		
Electrical	Outdoor-Indoor <sup>6</sup>	V, ph, Hz	208/230, 1, 60	208/230, 1, 60	208/230, 1, 60	208/230, 1, 60	208/230, 1, 60	
	Recommended Breaker Size	A	15	15	15	15	15	
Refrigerant Type			R410A	R410A	R410A	R410A	R410A	
Guaranteed Temperature Operation Range	Cooling <sup>7</sup>	°F DB [°C DB]	14 to 115 [-10 to 46]	14 to 115 [-10 to 46]	14 to 115 [-10 to 46]	14 to 115 [-10 to 46]	14 to 115 [-10 to 46]	
	Heating	°F DB [°C DB]	-4 to 75 [-20 to 24]	-4 to 75 [-20 to 24]	-4 to 75 [-20 to 24]	-4 to 75 [-20 to 24]	-4 to 75 [-20 to 24]	

Notes:  
AHRI Rated Conditions  
(Rated data is determined at a fixed compressor speed)

<sup>1</sup>Cooling (Indoor // Outdoor) °F 80 DB, 67 WB // 95 DB, 75 WB  
<sup>2</sup>Heating at 47°F (Indoor // Outdoor) °F 70 DB, 60 WB // 47 DB, 43 WB  
<sup>3</sup>Heating at 17°F (Indoor // Outdoor) °F 70 DB, 60 WB // 17 DB, 15 WB  
<sup>4</sup>Heating at 5°F (Indoor // Outdoor) °F 70 DB, 60 WB // 5 DB, 4 WB  
<sup>5</sup>Heating at -5°F (Indoor // Outdoor) °F 70 DB, 60 WB // -5 DB, -6 WB

Conditions

<sup>6</sup>Indoor units receive power from outdoor units through field-supplied interconnected wiring.

<sup>7</sup>Applications should be restricted to comfort cooling only; equipment cooling applications are not recommended for low ambient temperature conditions.



# MSZ-JP Model

115V Wall Mount



## Stylish Design

A stylish flat panel design creates a simple look that matches the decor in any room.



## Econo Cool Energy-Saving Feature

Econo Cool is an intelligent temperature control feature that adjusts the amount of air discharged based on the air-outlet temperature. The temperature set point can be raised up to 4° without any loss in comfort, thereby realizing a 20% gain in energy efficiency. (Function only available during manual cooling operation.)

	Conventional	Econo Cool
Ambient Temperature	95° F	95° F
Set point	77° F	81° F
Perceived Temperature	86° F	85° F

Econo Cool



Conventional Cooling Mode



Temperature distribution (° F)

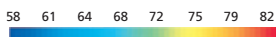

## Quiet Operation

A quiet, relaxing space is within reach. Operational noise is as low as 22dB(A).

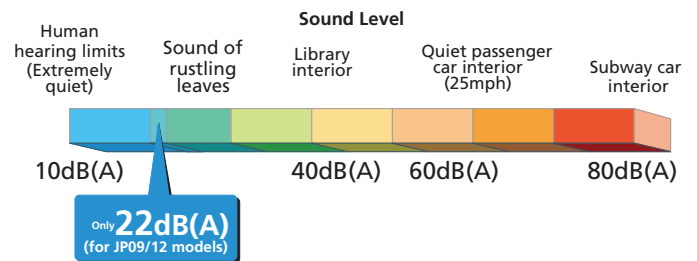

## Air Filter

This filter can remove dust particles from the air.

## Anti-allergy Enzyme Filter\* (\*Optional)

This filter works to trap allergens such as bacteria and decompose them using enzymes retained in the filter.

## 12-hour Timer

Allows for one ON/OFF cycle during a 12-hour period.

## Blue Fin Heat Exchanger

Blue Fin is an anti-corrosion coating applied to the heat exchanger of the outdoor unit. This treatment prevents the deterioration of the aluminum fins caused by salt, especially in coastal areas. (Corrosion of the heat exchanger will affect the efficiency and performance of the outdoor unit.)

# MSZ-JP Model

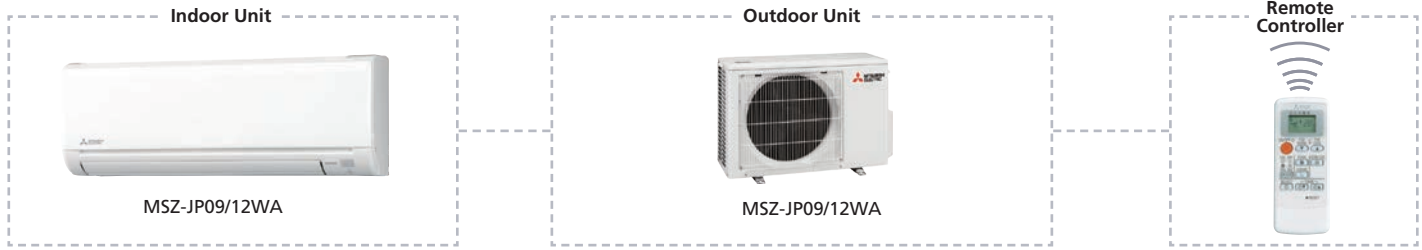

Indoor Unit				MSZ-JP09WA	MSZ-JP12WA
Outdoor Unit				MUZ-JP09WA	MUZ-JP12WA
Cooling	Capacity	Rated <sup>1</sup>	BTU/H	9,000	12,000
	Capacity Range	Min-Max	BTU/H	3,800-10,000	3,800-12,000
	Power Input	Rated <sup>1</sup>	W	750	1,210
	Moisture Removal		Pints/h	1.5	2.5
	Sensible Heat Factor			0.820	0.770
Heating	Capacity at 47°F	Rated <sup>2</sup>	BTU/H	10,900	12,200
	Capacity Range	Min-Max	BTU/H	4,500-11,800	4,500-14,500
	Power Input at 47°F	Rated <sup>2</sup>	W	900	990
	Capacity at 17°F	Rated <sup>3</sup>	BTU/H	6,700	7,600
		Max	BTU/H	7,200	9,000
	Capacity at 5°F	Max <sup>4</sup>	BTU/H	5,990	7,440
Efficiency	SEER			17.0	17.0
	EER			12.0	9.9
	HSPF			9.0	9.0
	COP			3.55	3.61
	ENERGY STAR® Certified			No	No
Indoor Unit	Air Flow Rate - Cooling (Quiet-Lo-Med-Hi-SHi)	Dry	CFM	170-237-321-399	170-237-321-399
	Air Flow Rate - Cooling (Quiet-Lo-Med-Hi-SHi)	Wet	CFM	134-201-286-364	134-201-286-364
	Air Flow Rate - Heating (Quiet-Lo-Med-Hi-SHi)	Dry	CFM	170-237-321-406	170-237-321-406
	Sound Pressure Level (Quiet-Lo-Med-Hi-SHi)	Cooling	dB(A)	22-30-37-43	22-30-37-43
	Sound Pressure Level (Quiet-Lo-Med-Hi-SHi)	Heating	dB(A)	22-30-37-43	22-30-37-43
	External Static Pressure		In. W.G.	—	—
	Condensate Lift Mechanism	Max Distance	In. [mm]	—	—
	Dimensions	H	In. [mm]	11-5/8 [295]	11-5/8 [295]
		W	In. [mm]	31-7/16 [798]	31-7/16 [798]
D		In. [mm]	9-1/8 [232]	9-1/8 [232]	
Weight		lbs [kg]	22 [10]	22 [10]	
Outdoor Unit	MCA	A		12.0	14.0
	MOCP	A		15	15
	Dimensions	H	In. [mm]	21-5/8 [550]	21-5/8 [550]
		W	In. [mm]	31-1/2 [800]	31-1/2 [800]
		D	In. [mm]	11-1/4 [285]	11-1/4 [285]
	Weight		lbs [kg]	73 [33]	73 [33]
	Air Flow Rate (Cooling/Heating)		CFM	1105/1225	1105/1225
Sound Pressure Level	Cooling	dB(A)	46	49	
	Heating	dB(A)	46	50	
Piping	Diameter	Gas (O.D.)	In. [mm]	3/8 [9.52]	3/8 [9.52]
		Liquid (O.D)	In. [mm]	1/4 [6.35]	1/4 [6.35]
		Indoor Drain	In. [mm]	5/8 [15.88]	5/8 [15.88]
Max. Length		ft [m]	40 [12]	40 [12]	
Max. Height		ft [m]	65 [20]	65 [20]	
Electrical	Outdoor-Indoor <sup>6</sup>		V, ph, Hz	115, 1, 60	115, 1, 60
	Recommended Breaker Size		A	15	15
Refrigerant Type				R410A	R410A
Guaranteed Temperature Operation Range	Cooling <sup>7</sup>	°F DB [°C DB]		14 to 115 [-10 to 46]	14 to 115 [-10 to 46]
	Heating	°F DB [°C DB]		-4 to 75 [-20 to 24]	-4 to 75 [-20 to 24]

Notes:  
 AHRI Rated Conditions (Rated data is determined at a fixed compressor speed)  
<sup>1</sup>Cooling (Indoor // Outdoor) °F 80 DB, 67 WB // 95 DB, 75 WB  
<sup>2</sup>Heating at 47°F (Indoor // Outdoor) °F 70 DB, 60 WB // 47 DB, 43 WB  
<sup>3</sup>Heating at 17°F (Indoor // Outdoor) °F 70 DB, 60 WB // 17 DB, 15 WB  
<sup>4</sup>Heating at 5°F (Indoor // Outdoor) °F 70 DB, 60 WB // 5 DB, 4 WB  
<sup>5</sup>Heating at -5°F (Indoor // Outdoor) °F 70 DB, 60 WB // -5 DB, -6 WB  
 Conditions  
<sup>6</sup>Indoor units receive power from outdoor units through field-supplied interconnected wiring.  
<sup>7</sup>Applications should be restricted to comfort cooling only; equipment cooling applications are not recommended for low ambient temperature conditions.



# MSZ-WR Model

16 SEER Wall Mount

## Stylish Design with Flat Panel Front

A stylish flat panel design creates a simple look that matches the decor in any room.



## Econo Cool Energy-Saving Feature

Econo Cool is an intelligent temperature control feature that adjusts the amount of air discharged based on the air-outlet temperature. The temperature set point can be raised up to 4° without any loss in comfort, thereby realizing a 20% gain in energy efficiency. (Function only available during manual cooling operation.)

	Conventional	Econo Cool
Ambient Temperature	95° F	95° F
Set point	77° F	81° F
Perceived Temperature	86° F	85° F

Econo Cool



Conventional Cooling Mode



Temperature distribution (° F)  
58 61 64 68 72 75 79 82

## Quiet Operation

A quiet, relaxing space is within reach. Operational noise is as low as 22dB(A).

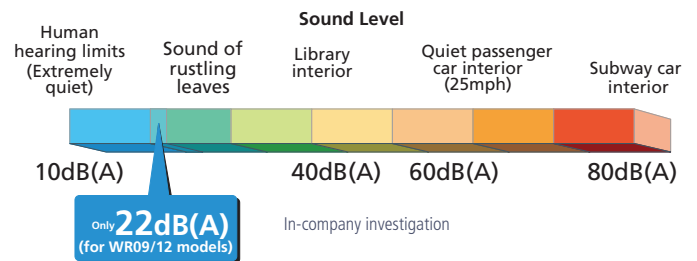

## Air Filter

This filter can remove dust particles from the air.

## Anti-allergy Enzyme Filter\* (\*Optional)

This filter works to trap allergens such as bacteria and decompose them using enzymes retained in the filter.

## 12-hour Timer

Allows for one ON/OFF cycle during a 12-hour period.

## Blue Fin Heat Exchanger

Blue Fin is an anti-corrosion coating applied to the heat exchanger of the outdoor unit. This treatment prevents the deterioration of the aluminum fins caused by salt, especially in coastal areas. (Corrosion of the heat exchanger will affect the efficiency and performance of the outdoor unit.)



# MSZ-WR Model

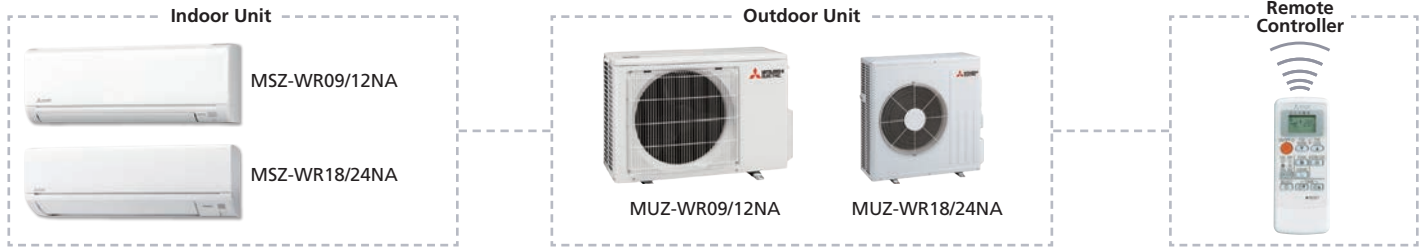

Indoor Unit				MSZ-WR09NA	MSZ-WR12NA	MSZ-WR18NA	MSZ-WR24NA
Outdoor Unit				MUZ-WR09NA-U2	MUZ-WR12NA-U2	MUZ-WR18NA-U2	MUZ-WR24NA
Cooling	Capacity	Rated <sup>1</sup>	BTU/H	9,000	12,000	17,200	22,500
	Capacity Range	Min-Max	BTU/H	3,800–10,000	3,800–12,200	5,800–18,000	5,800–22,500
	Power Input	Rated <sup>1</sup>	W	820	1,330	1,720	2,810
	Moisture Removal	Pints/h		1.5	2.5	2.1	2.3
	Sensible Heat Factor			0.820	0.770	0.860	0.890
Heating	Capacity at 47°F	Rated <sup>2</sup>	BTU/H	10,900	12,200	18,000	26,000
	Capacity Range	Min-Max	BTU/H	4,500–11,800	4,500–14,500	5,400–20,900	5,400–26,000
	Power Input at 47°F	Rated <sup>2</sup>	W	980	1,090	1,670	2,680
	Capacity at 17°F	Rated <sup>3</sup>	BTU/H	6,700	7,600	11,500	18,500
		Max	BTU/H	7,200	9,000	15,000	18,500
	Capacity at 5°F	Max <sup>4</sup>	BTU/H	5,990	7,440	12,780	15,600
Efficiency	Capacity at -5°F	Max <sup>5</sup>	BTU/H	—	—	—	—
	SEER			16.0	16.0	16.0	16.0
	EER			11.0	9.0	10.0	8.0
	HSPF			8.5	8.5	8.5	8.5
	COP			3.25	3.28	3.16	2.84
ENERGY STAR® Certified				No	No	No	No
Indoor Unit	Air Flow Rate - Cooling (Quiet-Lo-Med-Hi-SHi)	Dry	CFM	170–237–321–399	170–237–321–399	328–431–530–625	353–431–530–702
	Air Flow Rate - Cooling (Quiet-Lo-Med-Hi-SHi)	Wet	CFM	134–201–286–364	134–201–286–364	295–388–477–562	318–388–477–632
	Air Flow Rate - Heating (Quiet-Lo-Med-Hi-SHi)	Dry	CFM	170–237–321–406	170–237–321–406	307–431–530–625	346–448–579–702
	Sound Pressure Level (Quiet-Lo-Med-Hi-SHi)	Cooling	dB(A)	22–30–37–43	22–30–37–45	30–37–42–47	33–38–44–50
	Sound Pressure Level (Quiet-Lo-Med-Hi-SHi)	Heating	dB(A)	22–30–37–43	22–30–37–43	30–37–42–47	32–38–44–50
	External Static Pressure		In. W.G.	—	—	—	—
	Condensate Lift Mechanism	Max Distance	In. [mm]	—	—	—	—
	Dimensions	H	In. [mm]	11-5/8 [295]	11-5/8 [295]	12 [305]	12 [305]
		W	In. [mm]	31-7/16 [798]	31-7/16 [798]	36-5/16 [923]	36-5/16 [923]
		D	In. [mm]	9-1/8 [232]	9-1/8 [232]	9-13/16 [250]	9-13/16 [250]
Weight	lbs [kg]		22 [10]	22 [10]	28 [13]	28 [13]	
Outdoor Unit	MCA	A		9.0	10.0	9.0	14.0
	MOCP	A		15	15	15	15
	Dimensions	H	In. [mm]	21-5/8 [550]	21-5/8 [550]	34-5/8 [880]	34-5/8 [880]
		W	In. [mm]	31-1/2 [800]	31-1/2 [800]	31-1/16 [840]	31-1/16 [840]
		D	In. [mm]	11-1/4 [286]	11-1/4 [286]	13 [330]	13 [330]
	Weight	lbs [kg]		73 [33]	73 [33]	121 [55]	121 [55]
	Air Flow Rate (Cooling/Heating)	CFM		1151/1225	1243/1229	1151/1225	1691/1691
Sound Pressure Level	Cooling	dB(A)	51	53	48	57	
	Heating	dB(A)	51	51	50	55	
Piping	Diameter	Gas (O.D.)	In. [mm]	3/8 [9.52]	1/2 [12.7]	3/8 [9.52]	5/8 [15.88]
		Liquid (O.D)	In. [mm]	1/4 [6.35]	1/4 [6.35]	1/4 [6.35]	3/8 [9.52]
		Indoor Drain	In. [mm]	5/8 [15.88]	5/8 [15.88]	5/8 [15.88]	5/8 [15.88]
	Max. Length	ft [m]		40 [12]	40 [12]	40 [12]	50 [15]
Max. Height	ft [m]		65 [20]	65 [20]	65 [20]	100 [30]	
Electrical	Outdoor-Indoor <sup>6</sup>	V, ph, Hz		208/230, 1, 60	208/230, 1, 60	208/230, 1, 60	208/230, 1, 60
	Recommended Breaker Size	A		15	15	15	15
Refrigerant Type				R410A	R410A	R410A	R410A
Guaranteed Temperature Operation Range	Cooling <sup>7</sup>	°F DB [°C DB]		32 to 115 [-10 to 46]	32 to 115 [-10 to 46]	32 to 115 [-10 to 46]	32 to 115 [-10 to 46]
	Heating	°F DB [°C DB]		5 to 75 [-20 to 24]	5 to 75 [-20 to 24]	5 to 75 [-20 to 24]	5 to 75 [-20 to 24]

Notes:  
 AHRI Rated Conditions  
 (Rated data is determined at a fixed compressor speed)

<sup>1</sup>Cooling (Indoor // Outdoor) °F 80 DB, 67 WB // 95 DB, 75 WB  
<sup>2</sup>Heating at 47°F (Indoor // Outdoor) °F 70 DB, 60 WB // 47 DB, 43 WB  
<sup>3</sup>Heating at 17°F (Indoor // Outdoor) °F 70 DB, 60 WB // 17 DB, 15 WB  
<sup>4</sup>Heating at 5°F (Indoor // Outdoor) °F 70 DB, 60 WB // 5 DB, 4 WB  
<sup>5</sup>Heating at -5°F (Indoor // Outdoor) °F 70 DB, 60 WB // -5 DB, -6 WB

Conditions  
<sup>6</sup>Indoor units receive power from outdoor units through field-supplied interconnected wiring.  
<sup>7</sup>Applications should be restricted to comfort cooling only; equipment cooling applications are not recommended for low ambient temperature conditions.



# MFZ-KJ Model

Floor Mount



## Simple Flat Design

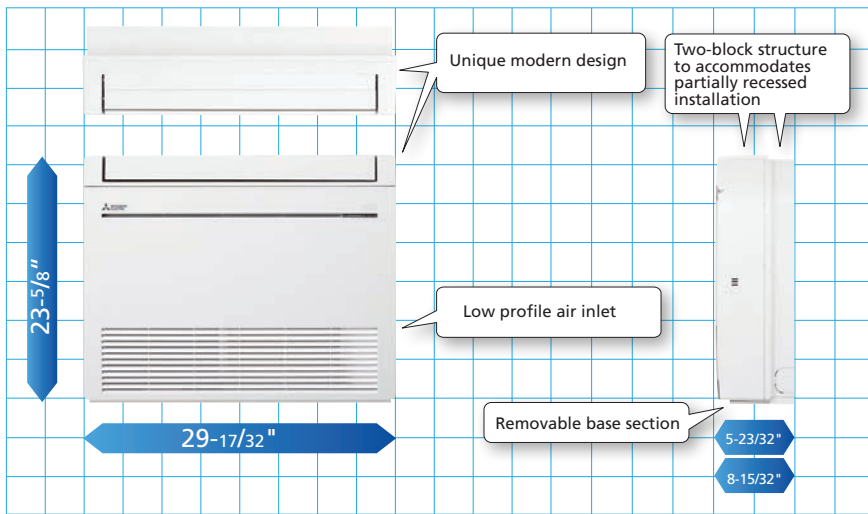

### Images Of Installed Unit

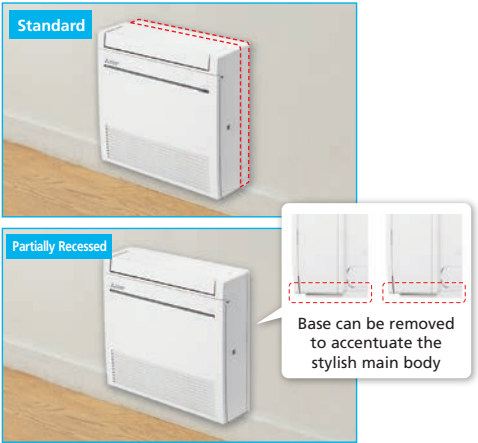

## Multi-Flow Vane

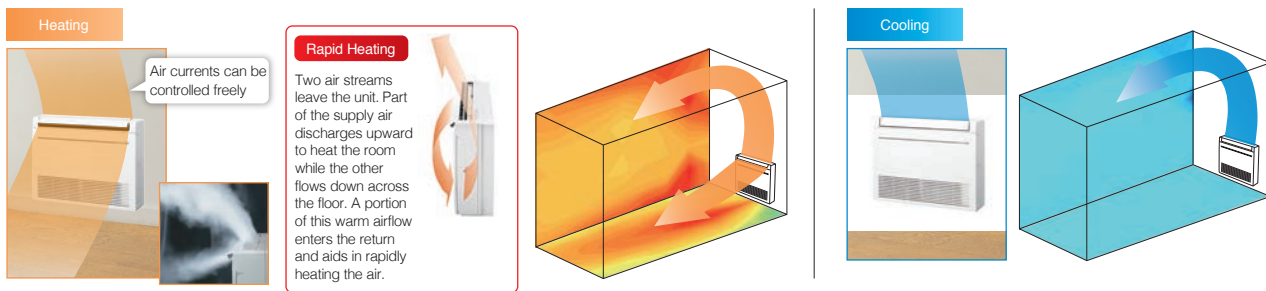

Air Distribution (MFZ-KJ15NA)  
(sectional view)

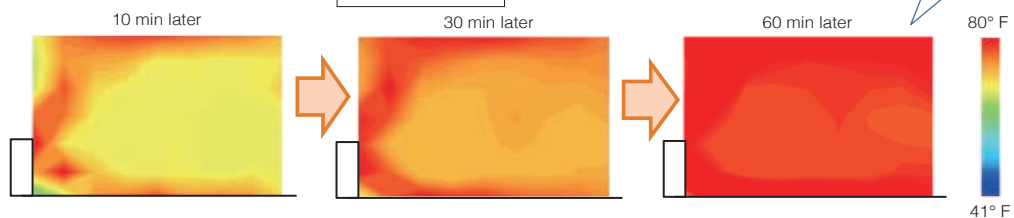

All MFZ-KJ single-zone systems are ENERGY STAR® certified.

# MFZ-KJ Model

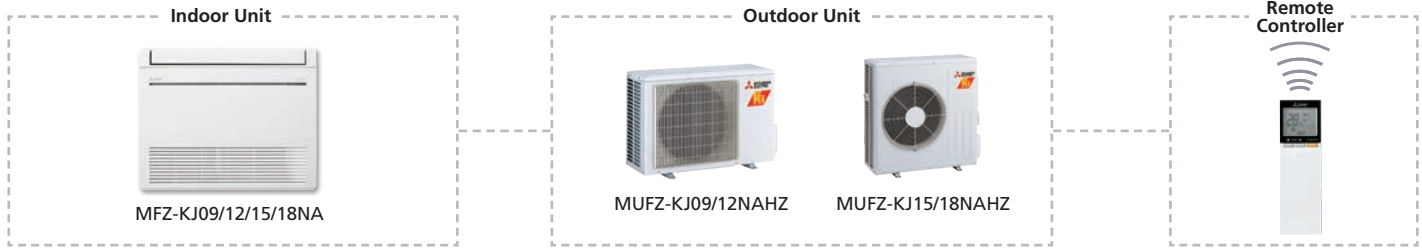

Indoor Unit				MFZ-KJ09NA	MFZ-KJ12NA	MFZ-KJ15NA	MFZ-KJ18NA
Outdoor Unit				MUFZ-KJ09NAHZ	MUFZ-KJ12NAHZ	MUFZ-KJ15NAHZ	MUFZ-KJ18NAHZ
Cooling	Capacity	Rated <sup>1</sup>	BTU/H	9,000	12,000	15,000	17,000
	Capacity Range	Min-Max	BTU/H	2,300-14,000	2,300-15,000	5,300-19,000	5,300-22,500
	Power Input	Rated <sup>1</sup>	W	570	890	1,120	1,350
	Moisture Removal	Pints/h		1.4	2.7	3.9	4.4
	Sensible Heat Factor			0.790	0.700	0.660	0.650
Heating	Capacity at 47°F	Rated <sup>2</sup>	BTU/H	11,000	13,000	18,000	21,000
	Capacity Range	Min-Max	BTU/H	2,900-19,000	2,900-22,800	5,700-25,000	5,700-29,000
	Power Input at 47°F	Rated <sup>2</sup>	W	750	900	1,410	1,730
	Capacity at 17°F	Rated <sup>3</sup>	BTU/H	7,500	8,800	12,000	12,800
	Capacity at 5°F	Max <sup>4</sup>	BTU/H	13,400	14,800	20,500	23,000
Efficiency	SEER			28.2	25.5	21.8	21.0
	EER			15.8	13.6	13.5	12.6
	HSPF			13.0	12.0	11.6	11.3
	COP			4.3	4.2	3.7	3.5
	ENERGY STAR® Certified			Yes	Yes	Yes	Yes
Indoor Unit	Air Flow Rate - Cooling (Quiet-Lo-Med-Hi-SHi)	Dry	CFM	138-198-272-360-417	138-198-272-360-417	198-254-311-392-431	198-254-328-420-491
	Air Flow Rate - Cooling (Quiet-Lo-Med-Hi-SHi)	Wet	CFM	117-168-231-306-354	117-168-231-306-354	168-216-264-333-366	168-216-279-357-417
	Air Flow Rate - Heating (Quiet-Lo-Med-Hi-SHi)	Dry	CFM	138-191-254-328-417	138-191-254-328-417	212-268-328-399-470	212-268-328-399-470
	Sound Pressure Level (Quiet-Lo-Med-Hi-SHi)	Cooling	dB(A)	21-27-34-41-46	21-27-34-41-46	28-33-38-43-47	28-33-39-45-50
	Sound Pressure Level (Quiet-Lo-Med-Hi-SHi)	Heating	dB(A)	21-27-34-40-46	21-27-34-40-46	29-35-40-45-49	29-35-40-45-49
	External Static Pressure		In. W.G.	—	—	—	—
	Condensate Lift Mechanism	Max Distance	In. [mm]	—	—	—	—
	Dimensions	H	In. [mm]	23-5/8 [600]	23-5/8 [600]	23-5/8 [600]	23-5/8 [600]
		W	In. [mm]	29-17/32 [750]	29-17/32 [750]	29-17/32 [750]	29-17/32 [750]
		D	In. [mm]	8-15/32 [215]	8-15/32 [215]	8-15/32 [215]	8-15/32 [215]
Weight	lbs [kg]		33 [15.0]	33 [15.0]	33 [15.0]	33 [15.0]	
Outdoor Unit	MCA	A		11.0	11.0	16.0	16.0
	MOCP	A		15	15	20	20
	Dimensions	H	In. [mm]	21-5/8 [550]	21-5/8 [550]	34-5/8 [880]	34-5/8 [880]
		W	In. [mm]	31-1/2 [800]	31-1/2 [800]	33-1/16 [840]	33-1/16 [840]
		D	In. [mm]	11-1/4 [285]	11-1/4 [285]	13 [330]	13 [330]
	Weight	lbs [kg]		83 [38]	83 [38]	124 [56]	124 [56]
	Air Flow Rate (Cooling/Heating)	CFM		1074/1202	1074/1202	1653/1730	1653/1730
	Sound Pressure Level	Cooling	dB(A)	48	48	51	51
		Heating	dB(A)	50	50	55	55
	Piping	Diameter	Gas (O.D.)	In. [mm]	3/8 [9.52]	3/8 [9.52]	1/2 [12.7]
Liquid (O.D)			In. [mm]	1/4 [6.35]	1/4 [6.35]	1/4 [6.35]	1/4 [6.35]
Indoor Drain			In. [mm]	5/8 O.D [15]	5/8 O.D [15]	5/8 O.D [15]	5/8 O.D [15]
Max. Length		ft [m]		65 [20]	65 [20]	100 [30]	100 [30]
Max. Height	ft [m]		40 [12]	40 [12]	50 [15]	50 [15]	
Electrical	Outdoor-Indoor <sup>6</sup>	V, ph, Hz		208/230, 1, 60	208/230, 1, 60	208/230, 1, 60	208/230, 1, 60
	Recommended Breaker Size	A		15	15	20	20
Refrigerant Type				R410A	R410A	R410A	R410A
Guaranteed Temperature Operation Range	Cooling <sup>7</sup>	°F DB [°C DB]		14 to 115 [-10 to 46]	14 to 115 [-10 to 46]	14 to 115 [-10 to 46]	14 to 115 [-10 to 46]
	Heating	°F DB [°C DB]		-13 to 75 [-25 to 24]	-13 to 75 [-25 to 24]	-13 to 75 [-25 to 24]	-13 to 75 [-25 to 24]

Notes:  
 AHRI Rated Conditions (Rated data is determined at a fixed compressor speed)  
 Conditions  
<sup>1</sup>Cooling (Indoor // Outdoor) °F 80 DB, 67 WB // 95 DB, 75 WB  
<sup>2</sup>Heating at 47°F (Indoor // Outdoor) °F 70 DB, 60 WB // 47 DB, 43 WB  
<sup>3</sup>Heating at 17°F (Indoor // Outdoor) °F 70 DB, 60 WB // 17 DB, 15 WB  
<sup>4</sup>Heating at 5°F (Indoor // Outdoor) °F 70 DB, 60 WB // 5 DB, 4 WB  
<sup>5</sup>Heating at -5°F (Indoor // Outdoor) °F 70 DB, 60 WB // -5 DB, -6 WB  
<sup>6</sup>Indoor units receive power from outdoor units through field-supplied interconnected wiring.  
<sup>7</sup>Applications should be restricted to comfort cooling only; equipment cooling applications are not recommended for low ambient temperature conditions.



# SUZ Models

Universal Outdoor



## Hyper-Heating Heat Pump

## Heat Pump



SUZ-KA09/12/15/18NAHZ



SUZ-KA24NAHZ



SUZ-KA30/36NAHZ



SUZ-KA09/12/15NA2



SUZ-KA18/24/30/36NA2



MLZ



SLZ



SEZ

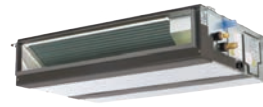



PEAD



SVZ

## System Compatibility

Outdoor Unit Capacity KBTU/H		9		12		15		18		24		30		36	
Model	Type	HP		HP		HP		HP		HP		HP		HP	
SLZ-KF	2' x 2' cassette	•	•	•	•	•	•	•	•						
SEZ-KD	Low static ducted	•	•	•	•	•	•	•	•						
PEAD	Mid static ducted	•	•	•	•	•	•	•	•	•	•	•	•	•	•
SVZ	Multi-position Air Handler			•	•			•	•	•	•	•	•	•	•
MLZ-KP	EZ FIT™ Recessed Ceiling Cassette	•	•	•	•			•	•						

Available capacities in KBTU/H: 9, 12, 15, 18, 24, 30, 36. Single-zone outdoor unit matches multiple indoor unit options Heat Pump or Hyper-Heating INVERTER®



Most SUZ systems are ENERGY STAR® certified.

# Hyper-Heating INVERTER®

The H2i® models provide heating even when it's -13° F (-25° C) outdoor ambient temperature, producing up to 100% heating capacity at 5° F (-15° C). These units offer year-round comfort even in extreme climates.

## Heating Performance at Low Temperatures

SUZ-KA09NAHZ					SUZ-KA09NAHZ					SUZ-KA18NAHZ						
COP at	SLZ	SEZ	PEAD	MLZ	COP at	SLZ	SEZ	PEAD	SVZ	MLZ	COP at	SLZ	SEZ	PEAD	SVZ	MLZ
47° F	3.90	2.80	3.80	4.10	47° F	3.40	3.90	3.90	3.80	3.80	47° F	3.40	3.90	3.30	3.30	3.00
17° F	2.56	2.20	2.56	2.76	17° F	2.38	2.56	2.72	2.61	2.54	17° F	2.10	2.00	2.49	2.32	2.42
5° F	1.34	1.59	1.67	1.67	5° F	1.83	2.19	2.09	1.69	1.57	5° F	1.75	1.75	1.66	1.75	1.39

SUZ-KA15NAHZ				SUZ-KA24NAHZ			SUZ-KA30NAHZ			SUZ-KA36NAHZ		
COP at	SLZ	SEZ	PEAD	COP at	PEAD	SVZ	COP at	PEAD	SVZ	COP at	PEAD	SVZ
47° F	2.60	2.70	3.00	47° F	3.80	3.10	47° F	3.40	3.90	47° F	3.70	3.30
17° F	1.91	2.15	2.29	17° F	2.10	1.80	17° F	2.10	2.0	17° F	2.20	1.80
5° F	1.84	1.88	1.81	5° F	1.75	1.60	5° F	1.75	1.75	5° F	1.75	1.60

Operation guaranteed at -13° F,  
100% heating capacity at 5° F

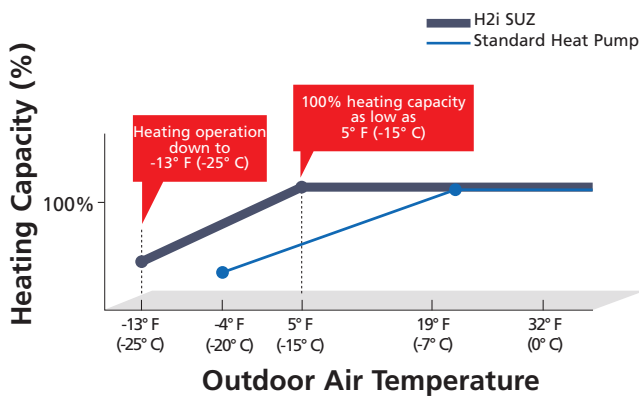

## Built-in Base Heater

The base heater restricts lowered capacity and operation shutdowns caused by the drain water freezing. This feature supports stable operation in low-temperature environments.

Operation Guaranteed at Outside Temperature of -13° F (-25° C)

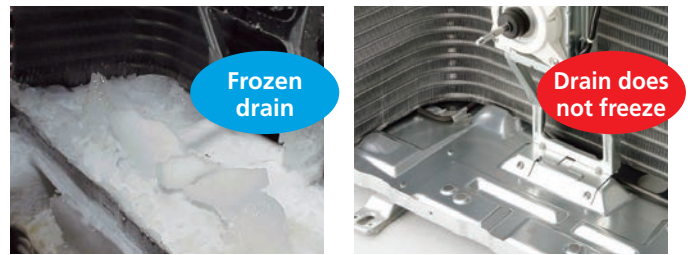

Without Base Heater

With Base Heater

## Compact and Powerful Compressor

Manufacturing with Heat Caulking Fixing Method reduces compressor size while maintaining a high compressor output. This technology enables the installation of a more powerful compressor in compact outdoor units. As a result, it is possible to achieve excellent heating performance while operating in cold outdoor environments.

### Compressor Using Conventional Method (Arc Spot-Welded Method)

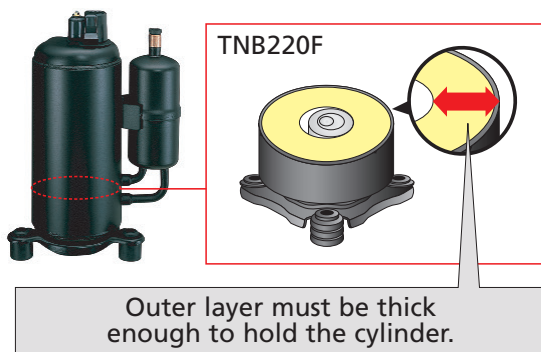

### Compressor Using Heat Caulking Fixing Method

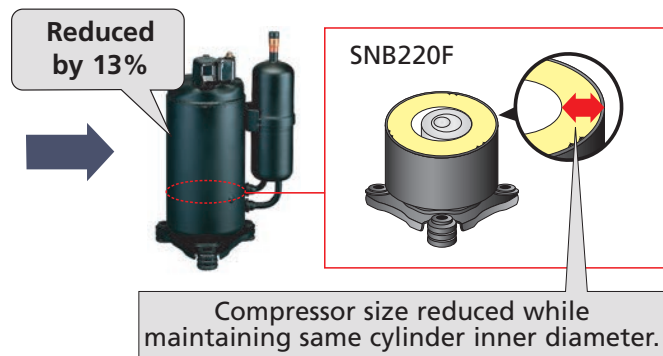



# MLZ Model

EZ FIT® Recessed Ceiling Cassette



## Slim Design



## Ceiling Recessed

The EZ FIT flush-mount design creates a more spacious feeling in the room. The recessed-ceiling-cassette indoor unit style provides a solution when wall space is limited or not available.

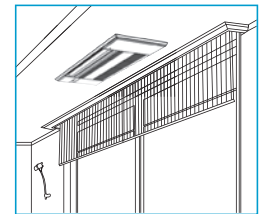

## Slim Body

The units are built with a slim body (only 7-5/16"), ensuring easy installation even when shallow ceiling cavities limit installation space. The inventive design also eliminates the need for an extra service access panel, further reducing the required installation area.



## Set Airflow According to Ceiling Height

Dual-level airflow selection is engineered to accommodate specific ceiling heights. This is a key feature for adjusting airflow effectively when it is either too strong or too weak due to being mismatched with the ceiling height.

	09	12	18
Standard	7' 10-1/2"	7' 10-1/2"	7' 10-1/2"
High Ceiling	8' 10-1/2"	8' 10-1/2"	8' 10-1/2"

## Auto Vane Control

Outlet vanes can be moved left and right, and up and down using the remote controller. This improved airflow control feature eliminates drafts..

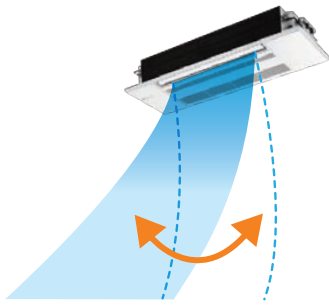

Up and Down

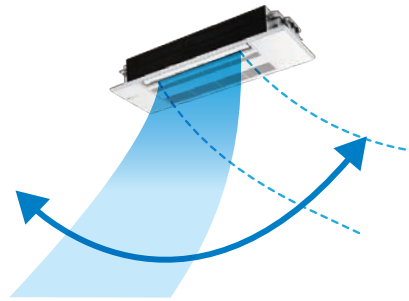

Left and Right

\*Only available when Econo Cool is set.

## Built-in Weekly Timer Function

Easily set desired temperatures and operation ON/OFF times to match lifestyle patterns. Reduce wasted energy consumption by using the timer to prevent forgetting to turn off the unit and eliminate temperature setting adjustments.

### Example Operation Pattern (Winter/Heating mode)

	Mon.	Tues.	Wed.	Thurs.	Fri.	Sat.	Sun.
6:00 AM	ON 68°F	ON 68°F	ON 68°F	ON 68°F	ON 68°F	ON 68°F	ON 68°F
8:00 AM	Automatically changes to high-power operation at wake-up time						
10:00 AM	OFF	OFF	OFF	OFF	OFF	ON 64°F	ON 64°F
12:00 AM	Automatically turned off during work hours					Midday is warmer, so the temperature is set lower	
2:00 PM							
4:00 PM							
6:00 PM	ON 72°F	ON 72°F	ON 72°F	ON 72°F	ON 72°F	ON 72°F	ON 72°F
8:00 PM	Automatically turns on, synchronized with arrival at home					Automatically raises temperature setting to match time when outside-air temperature is low	
10:00 PM							
(during sleeping hours)	ON 64°F	ON 64°F	ON 64°F	ON 64°F	ON 64°F	ON 64°F	ON 64°F
	Automatically lowers temperature at bedtime for energy-saving operation at night						

#### Settings

**Pattern Settings:** Input up to four settings for each day  
**Settings:** • Start/Stop operation • Temperature setting \*The operation mode cannot be set.

## Easy Set-Up Using Dedicated Buttons

The remote controller is equipped with buttons that are used exclusively for setting the Weekly Timer. Setting operation patterns is easy and quick.



How to set the Weekly Timer

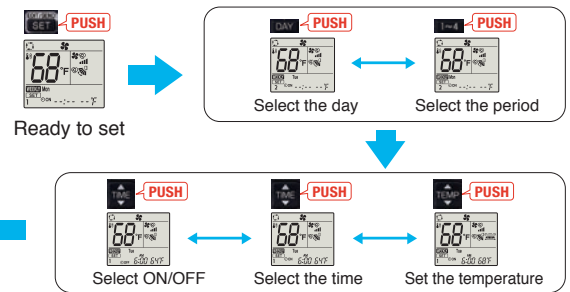

Start by pushing the SET button and follow the instructions to set the desired patterns. Once all of the desired patterns are input, point the top end of the remote controller at the indoor unit and push the SET button one more time. (Push the SET button only after inputting all of the desired patterns into the remote controller memory. Pushing the CANCEL button will end the set-up process without sending the operation patterns to the indoor unit).



# Easy Installation

## Industry Leading Slim Body

The EZ FIT® installs between standard joists that span 16 inches on center. There is no need for large scale construction, such as the cutting of the joist.



## Temporary Hanging Hook

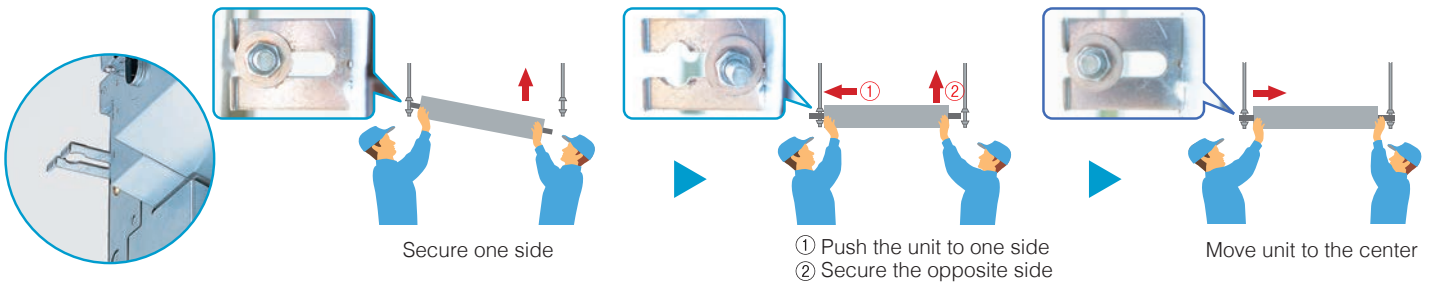

## Drain Piping Supporters and Drain Cover

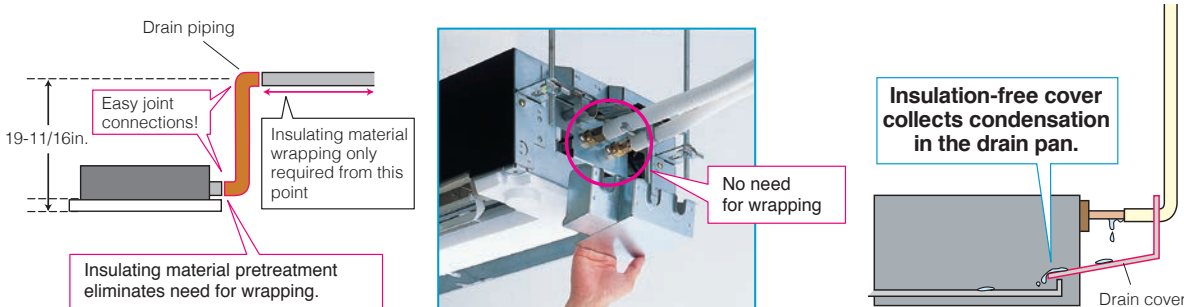

## Wireless Interface Installation (Optional)

The indoor unit panel is equipped with a Wireless Interface pocket, contributing to the beautiful appearance, easy installation and maintenance.

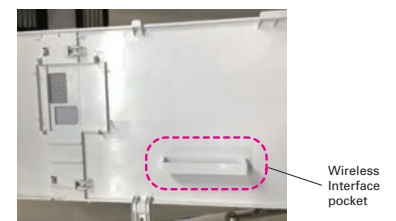



# MLZ Model



Indoor Unit				MLZ-KP09NA	MLZ-KP12NA	MLZ-KP18NA
Outdoor Unit				SUZ-KA09NA2	SUZ-KA12NA2	SUZ-KA18NA2
Cooling	Capacity	Rated <sup>1</sup>	BTU/H	9,000	12,000	18,000
	Capacity Range	Min-Max	BTU/H	3,600–9,000	3,900–12,000	6,600–18,000
	Power Input	Rated <sup>1</sup>	W	710	960	1,440
	Moisture Removal	Pints/h		1.5	2.8	5.3
	Sensible Heat Factor			0.820	0.740	0.670
Heating	Capacity at 47°F	Rated <sup>2</sup>	BTU/H	12,000	15,400	20,000
	Capacity Range	Min-Max	BTU/H	4,010–13,000	4,600–17,000	8,200–22,800
	Power Input at 47°F	Rated <sup>2</sup>	W	860	1,300	1,170
	Capacity at 17°F	Rated <sup>3</sup>	BTU/H	7,700	9,900	13,100
	Capacity at 5°F	Max <sup>4</sup>	BTU/H	7,700	9,900	13,100
	Capacity at -5°F	Max <sup>5</sup>	BTU/H	6,100	7,900	10,700
Efficiency	SEER			19.5	19.8	22.3
	EER			12.6	12.5	12.5
	HSPF			13.3	12.1	12.4
	COP			4.0	3.4	3.3
	ENERGY STAR® Certified			Yes	Yes	Yes
Indoor Unit	Air Flow Rate - Cooling (Quiet-Lo-Med-Hi-SHi)	Dry	CFM	212–254–283–311	212–258–297–332	212–293–346–403
	Air Flow Rate - Cooling (Quiet-Lo-Med-Hi-SHi)	Wet	CFM	180–216–240–264	180–219–252–282	180–249–294–343
	Air Flow Rate - Heating (Quiet-Lo-Med-Hi-SHi)	Dry	CFM	212–247–290–325	212–272–311–350	212–311–364–417
	Sound Pressure Level (Quiet-Lo-Med-Hi-SHi)	Cooling	dB(A)	27–31–34–38	27–32–36–40	29–36–41–47
	Sound Pressure Level (Quiet-Lo-Med-Hi-SHi)	Heating	dB(A)	26–29–34–37	26–32–36–40	26–37–42–48
	External Static Pressure		In. W.G.	—	—	—
	Condensate Lift Mechanism	Max Distance	In. [mm]	19-11/16 [500]	19-11/16 [500]	19-11/16 [500]
	Dimensions	H	In. [mm]	7-5/16 [185]	7-5/16 [185]	7-5/16 [185]
		W	In. [mm]	43-3/8 [1102]	43-3/8 [1102]	43-3/8 [1102]
		D	In. [mm]	14-3/16 [360]	14-3/16 [360]	14-3/16 [360]
Weight	lbs [kg]		34 [15.5]	34 [15.5]	34 [15.5]	
Outdoor Unit	MCA	A		9.0	9.0	14.0
	MOCP	A		15	16	24
	Dimensions	H	In. [mm]	21-5/8 [550]	21-5/8 [550]	34-5/8 [880]
		W	In. [mm]	31-1/2 [800]	31-1/2 [800]	33-1/16 [840]
		D	In. [mm]	11-1/4 [285]	11-1/4 [285]	13 [330]
	Weight	lbs [kg]		81 [37]	81 [37]	127 [58]
	Air Flow Rate (Cooling/Heating)	CFM		1228/1172	1228/1172	1691/1691
	Sound Pressure Level	Cooling	dB(A)	48	49	54
Heating		dB(A)	50	51	55	
Piping	Diameter	Gas (O.D.)	In. [mm]	3/8 [9.52]	3/8 [9.52]	1/2 [12.7]
		Liquid (O.D.)	In. [mm]	1/4 [6.35]	1/4 [6.35]	1/4 [6.35]
		Indoor Drain	In. [mm]	1-1/4 [32]	1-1/4 [32]	1-1/4 [32]
	Max. Length	ft [m]		65 [20]	65 [20]	100 [30]
Max. Height	ft [m]		40 [12]	40 [12]	50 [15]	
Electrical	Outdoor-Indoor <sup>6</sup>	V, ph, Hz		208/230, 1, 60	208/230, 1, 60	208/230, 1, 60
	Recommended Breaker Size	A		15	15	25
Refrigerant Type				R410A	R410A	R410A
Guaranteed Temperature Operation Range	Cooling <sup>7</sup>	°F DB [°C DB]		14 to 115 [-10 to 46]	14 to 115 [-10 to 46]	14 to 115 [-10 to 46]
	Heating	°F DB [°C DB]		-4 to -75 [-20 to 24]	-4 to -75 [-20 to 24]	-4 to -75 [-20 to 24]

Notes:  
 AHRI Rated Conditions (Rated data is determined at a fixed compressor speed)  
<sup>1</sup>Cooling (Indoor // Outdoor) °F 80 DB, 67 WB // 95 DB, 75 WB  
<sup>2</sup>Heating at 47°F (Indoor // Outdoor) °F 70 DB, 60 WB // 47 DB, 43 WB  
<sup>3</sup>Heating at 17°F (Indoor // Outdoor) °F 70 DB, 60 WB // 17 DB, 15 WB  
<sup>4</sup>Heating at 5°F (Indoor // Outdoor) °F 70 DB, 60 WB // 5 DB, 4 WB  
<sup>5</sup>Heating at -5°F (Indoor // Outdoor) °F 70 DB, 60 WB // -5 DB, -6 WB  
 Conditions  
<sup>6</sup>Indoor units receive power from outdoor units through field-supplied interconnected wiring.  
<sup>7</sup>Applications should be restricted to comfort cooling only; equipment cooling applications are not recommended for low ambient temperature conditions.

# MLZ Model

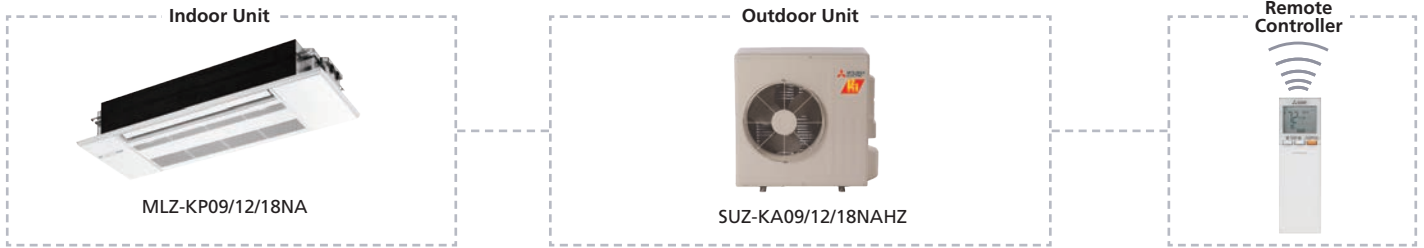

Indoor Unit				MLZ-KP09NA	MLZ-KP12NA	MLZ-KP18NA	
Outdoor Unit				SUZ-KA09NAHZ	SUZ-KA12NAHZ	SUZ-KA18NAHZ	
Cooling	Capacity	Rated <sup>1</sup>	BTU/H	9,000	12,000	16,700	
	Capacity Range	Min-Max	BTU/H	4,800-9,000	5,270-12,000	8,740-16,700	
	Power Input	Rated <sup>1</sup>	W	720	940	1,335	
	Moisture Removal	Pints/h		1.8	3.1	5.1	
	Sensible Heat Factor			0.780	0.710	0.660	
Heating	Capacity at 47°F	Rated <sup>2</sup>	BTU/H	12,000	15,000	18,600	
	Capacity Range	Min-Max	BTU/H	8,300-14,000	7,800-18,000	8,500-22,000	
	Power Input at 47°F	Rated <sup>2</sup>	W	840	1,130	1,780	
	Capacity at 17°F	Rated <sup>3</sup>	BTU/H	6,600	9,100	11,800	
		Max	BTU/H	12,000	15,000	18,600	
	Capacity at 5°F	Max <sup>4</sup>	BTU/H	12,000	15,000	18,600	
Efficiency	SEER			18.9	19.0	18.8	
	EER			12.5	12.7	12.5	
	HSPF			11.0	10.2	10.0	
	COP			4.1	3.8	3.0	
	ENERGY STAR® Certified			Yes	Yes	Yes	
	Indoor Unit	Air Flow Rate - Cooling (Quiet-Lo-Med-Hi-SHi)	Dry	CFM	212-254-283-311	212-258-297-332	212-293-346-403
Air Flow Rate - Cooling (Quiet-Lo-Med-Hi-SHi)		Wet	CFM	180-216-240-264	180-219-252-282	180-249-294-343	
Air Flow Rate - Heating (Quiet-Lo-Med-Hi-SHi)		Dry	CFM	212-247-290-325	212-272-311-350	212-311-364-417	
Sound Pressure Level (Quiet-Lo-Med-Hi-SHi)		Cooling	dB(A)	27-31-34-38	27-32-36-40	29-36-41-47	
Sound Pressure Level (Quiet-Lo-Med-Hi-SHi)		Heating	dB(A)	26-29-34-37	26-32-36-40	26-37-42-48	
External Static Pressure			In. W.G.	—	—	—	
Condensate Lift Mechanism		Max Distance	In. [mm]		19-11/16 [500]	19-11/16 [500]	19-11/16 [500]
		H	In. [mm]		7-5/16 [185]	7-5/16 [185]	7-5/16 [185]
		W	In. [mm]		43-3/8 [1102]	43-3/8 [1102]	43-3/8 [1102]
		D	In. [mm]		14-3/16 [360]	14-3/16 [360]	14-3/16 [360]
Weight	lbs [kg]		34 [15.5]	34 [15.5]	34 [15.5]		
Outdoor Unit	MCA	A		14.0	14.0	17.0	
	MOCP	A		24	24	31	
	Dimensions	H	In. [mm]		34-5/8 [880]	34-5/8 [880]	34-5/8 [880]
		W	In. [mm]		38-1/16 [840]	33-1/16 [840]	33-1/16 [840]
		D	In. [mm]		13 [330]	13 [330]	13 [330]
	Weight	lbs [kg]		129 [58.5]	129 [58.5]	131 [59.5]	
	Air Flow Rate (Cooling/Heating)	CFM		1,691/1,691	1,691/1,691	2,020/1,930	
	Sound Pressure Level	Cooling	dB(A)		54	54	55
		Heating	dB(A)		55	55	55
	Piping	Diameter	Gas (O.D.)	In. [mm]	3/8 [9.52]	3/8 [9.52]	1/2 [12.7]
Liquid (O.D)			In. [mm]	1/4 [6.35]	1/4 [6.35]	1/4 [6.35]	
Indoor Drain			In. [mm]	1-1/4 [32]	1-1/4 [32]	1-1/4 [32]	
Max. Length		ft [m]		65 [20]	65 [20]	100 [30]	
Max. Height	ft [m]		40 [12]	40 [12]	50 [15]		
Electrical	Outdoor-Indoor <sup>6</sup>	V, ph, Hz		208/230, 1, 60	208/230, 1, 60	208/230, 1, 60	
	Recommended Breaker Size	A		15	15	20	
Refrigerant Type				R410A	R410A	R410A	
Guaranteed Temperature Operation Range	Cooling <sup>7</sup>	°F DB [°C DB]		14 to 115 [-10 to 46]	14 to 115 [-10 to 46]	14 to 115 [-10 to 46]	
	Heating	°F DB [°C DB]		-13 to -75 [-25 to 24]	-13 to -75 [-25 to 24]	-13 to -75 [-25 to 24]	

Notes:  
 AHRI Rated Conditions (Rated data is determined at a fixed compressor speed)  
<sup>1</sup>Cooling (Indoor // Outdoor) °F 80 DB, 67 WB // 95 DB, 75 WB °C 27 DB, 60 WB // 47 DB, 43 WB  
<sup>2</sup>Heating at 47°F (Indoor // Outdoor) °F 70 DB, 60 WB // 17 DB, 15 WB °C 21 DB, 60 WB // 5 DB, 4 WB  
<sup>3</sup>Heating at 17°F (Indoor // Outdoor) °F 70 DB, 60 WB // 5 DB, 4 WB °C 21 DB, 60 WB // 5 DB, 4 WB  
<sup>4</sup>Heating at 5°F (Indoor // Outdoor) °F 70 DB, 60 WB // 5 DB, 4 WB °C 21 DB, 60 WB // 5 DB, 4 WB  
<sup>5</sup>Heating at -5°F (Indoor // Outdoor) °F 70 DB, 60 WB // 5 DB, 4 WB °C 21 DB, 60 WB // 5 DB, 4 WB  
<sup>6</sup>Indoor units receive power from outdoor units through field-supplied interconnected wiring.  
<sup>7</sup>Applications should be restricted to comfort cooling only; equipment cooling applications are not recommended for low ambient temperature conditions.



# SVZ Model

Multi-position Air Handler



The multi-position air handler is well-suited for supplemental or replacement applications. This product provides the powerful, quiet, and efficient cooling and heating solution your home or business deserves.

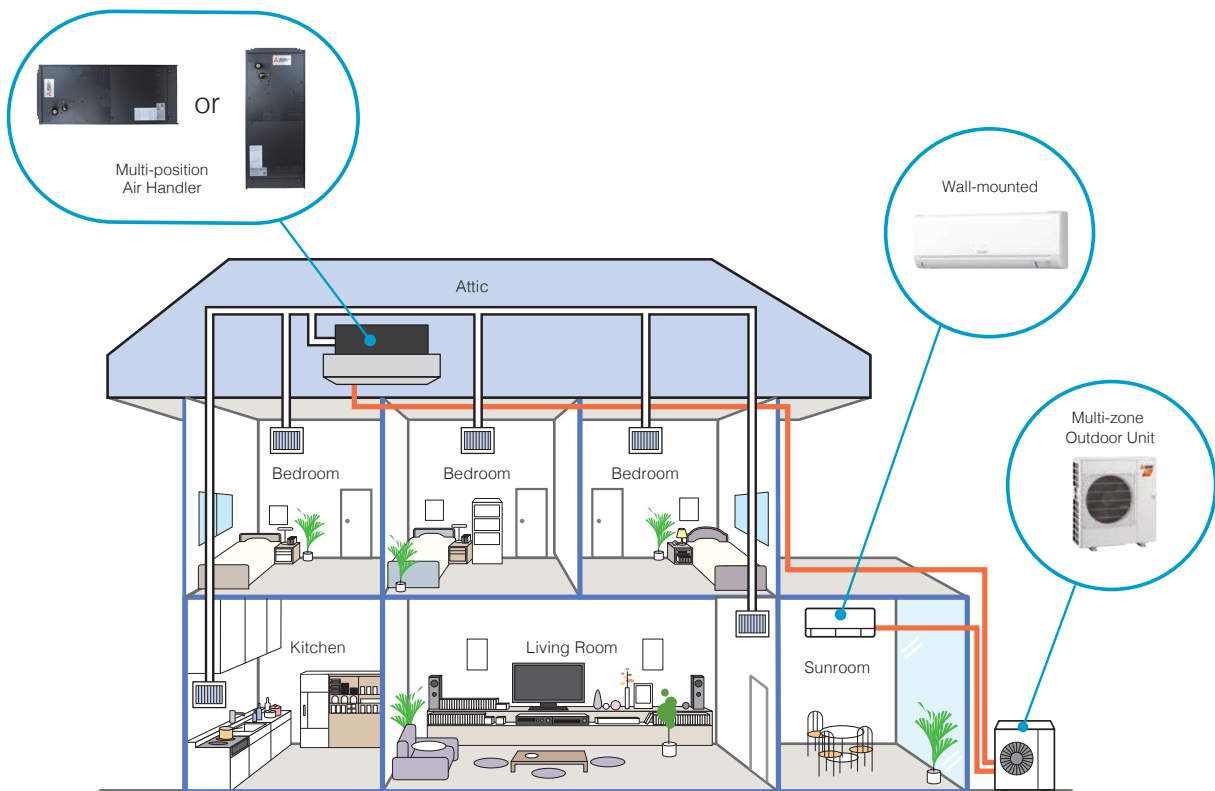

## Small Footprint

This air handler's compact design makes it possible to replace existing furnaces or air handlers. Choose either a single-zone or multi-zone system. Hybrid multi-zone applications provide a unique approach to solving zoning problems by mixing ducted and ductless indoor units.

## Flexibility

The SVZ air handler is truly multi-positional unit offering up, down\*, left or right airflow, making it ideal for tight and unique spaces.

\*Downflow kit required for downflow installations

## Quiet

The DC motor ensures quiet and efficient operation year round.

# SVZ Model

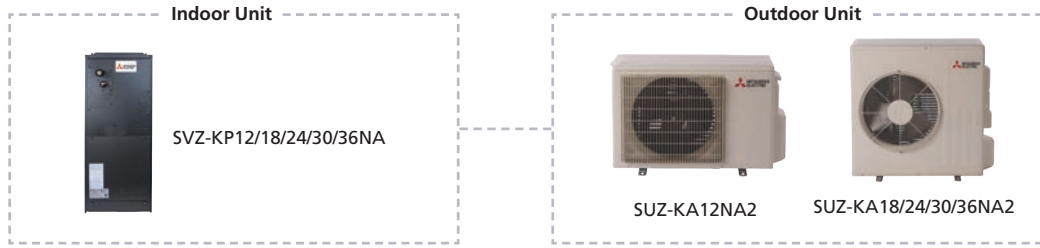

\* To confirm compatibility with the MXZ Model multi-zone system, refer to MXZ Model page.

Indoor Unit				SVZ-KP12NA	SVZ-KP18NA	SVZ-KP24NA	SVZ-KP30NA	SVZ-KP36NA
Outdoor Unit				SUZ-KA12NA2	SUZ-KA18NA2	SUZ-KA24NA2	SUZ-KA30NA2	SUZ-KA36NA2
Cooling	Capacity	Rated <sup>1</sup>	BTU/H	12,000	18,000	24,000	27,000	33,400
	Capacity Range	Min-Max	BTU/H	4,300-12,000	6,200-18,000	12,400-24,000	13,500-27,000	11,600-33,400
	Power Input	Rated <sup>1</sup>	W	940	1,360	1,920	2,160	3,711
	Moisture Removal	Pints/h		1.2	2.4	4.1	2.4	4.7
	Sensible Heat Factor			0.890	0.850	0.810	0.900	0.840
Heating	Capacity at 47°F	Rated <sup>2</sup>	BTU/H	15,000	21,600	25,000	30,000	33,400
	Capacity Range	Min-Max	BTU/H	4,700-16,700	8,300-26,000	14,600-28,000	12,640-33,000	13,260-36,000
	Power Input at 47°F	Rated <sup>2</sup>	W	1,210	1,600	1,910	2,060	3,030
	Capacity at 17°F	Rated <sup>3</sup>	BTU/H	9,900	14,000	14,600	21,400	23,200
	Capacity at 5°F	Max <sup>4</sup>	BTU/H	9,900	14,000	14,600	21,400	23,200
	Capacity at -5°F	Max <sup>5</sup>	BTU/H	7,800	12,200	—	—	—
Efficiency	SEER			18.0	18.0	18.0	18.0	16.0
	EER			12.7	13.2	12.5	12.5	9.0
	HSPF			12.1	12.6	10.4	13.6	11.7
	COP			3.6	3.9	3.8	4.2	3.2
	ENERGY STAR® Certified			Yes	Yes	Yes	Yes	No
Indoor Unit	Air Flow Rate - Cooling (Quiet-Lo-Med-Hi-SHi)	Dry	CFM	278-381-448	471-573-675	515-625-735	613-744-875	767-910-910
	Air Flow Rate - Cooling (Quiet-Lo-Med-Hi-SHi)	Wet	CFM	—	—	—	—	—
	Air Flow Rate - Heating (Quiet-Lo-Med-Hi-SHi)	Dry	CFM	278-381-448	471-573-675	515-625-735	613-744-875	767-910-910
	Sound Pressure Level (Quiet-Lo-Med-Hi-SHi)	Cooling	dB(A)	29-36-39	33-36-41	33-36-41	32-37-41	35-40-42
	Sound Pressure Level (Quiet-Lo-Med-Hi-SHi)	Heating	dB(A)	29-36-39	33-36-41	33-36-41	32-37-41	35-40-42
	External Static Pressure		In. W.G.	0.30-0.5-0.8	0.30-0.5-0.8	0.30-0.5-0.8	0.30-0.5-0.8	0.30-0.5-0.8
	Condensate Lift Mechanism	Max Distance	In. [mm]	—	—	—	—	—
	Dimensions	H	In. [mm]	34-5/8 [880]	39-13/16 [1011]	39-13/16 [1011]	43-3/4 [1111]	43-3/4 [1111]
		W	In. [mm]	33-1/16 [840]	17 [432]	17 [432]	21 [533]	21 [533]
		D	In. [mm]	13 [330]	21-5/8 [549]	21-5/8 [549]	21-5/8 [549]	21-5/8 [549]
Weight	lbs [kg]		93 [42]	93 [42]	93 [42]	119 [54]	119 [54]	
Outdoor Unit	MCA	A		9.0	14.0	17.0	17.0	17.0
	MOCP	A		16	24	31	31	31
	Dimensions	H	In. [mm]	21-5/8 [550]	34-5/8 [880]	34-5/8 [880]	34-5/8 [880]	34-5/8 [880]
		W	In. [mm]	31-1/2 [800]	33-1/16 [840]	33-1/16 [840]	33-1/16 [840]	33-1/16 [840]
		D	In. [mm]	11-1/4 [285]	13 [330]	13 [330]	13 [330]	13 [330]
	Weight	lbs [kg]		81 [37]	127 [58]	129 [59]	129 [59]	129 [59]
	Air Flow Rate (Cooling/Heating)	CFM		1228/1172	1691/1691	2020/1930	2020/1930	2020/1930
Sound Pressure Level	Cooling	dB(A)	49	54	55	55	55	
	Heating	dB(A)	51	55	55	55	55	
Piping	Diameter	Gas (O.D.)	In. [mm]	3/8 [9.52]	1/2 [12.7]	5/8 [15.88]	5/8 [15.88]	5/8 [15.88]
		Liquid (O.D.)	In. [mm]	1/4 [6.35]	1/4 [6.35]	3/8 [9.52]	3/8 [9.52]	3/8 [9.52]
		Indoor Drain	In. [mm]	3/4 [19.05]	3/4 [19.05]	3/4 [19.05]	3/4 [19.05]	3/4 [19.05]
	Max. Length	ft [m]		65 [20]	100 [30]	100 [30]	100 [30]	100 [30]
Max. Height	ft [m]		40 [12]	50 [15]	100 [30]	100 [30]	100 [30]	
Electrical	Outdoor-Indoor <sup>6</sup>	V, ph, Hz		208/230, 1, 60	208/230, 1, 60	208/230, 1, 60	208/230, 1, 60	208/230, 1, 60
	Recommended Breaker Size	A		15	15	20	20	20
Refrigerant Type				R410A	R410A	R410A	R410A	R410A
Guaranteed Temperature Operation Range	Cooling <sup>7</sup>	°F DB [°C DB]		14 to 115 [-10.0 to 46.0]	14 to 115 [-10.0 to 46.0]	14 to 115 [-10.0 to 46.0]	14 to 115 [-10.0 to 46.0]	14 to 115 [-10.0 to 46.0]
	Heating	°F DB [°C DB]		-4 to -75 [-20.0 to 24.0]	-4 to -75 [-20.0 to 24.0]	14 to -75 [-10.0 to 24.0]	14 to -75 [-10.0 to 24.0]	14 to -75 [-10.0 to 24.0]

Notes:  
 AHRI Rated Conditions (Rated data is determined at a fixed compressor speed)  
<sup>1</sup>Cooling (Indoor // Outdoor) °F 80 DB, 67 WB // 95 DB, 75 WB  
<sup>2</sup>Heating at 47°F (Indoor // Outdoor) °F 70 DB, 60 WB // 47 DB, 43 WB  
<sup>3</sup>Heating at 17°F (Indoor // Outdoor) °F 70 DB, 60 WB // 17 DB, 15 WB  
<sup>4</sup>Heating at 5°F (Indoor // Outdoor) °F 70 DB, 60 WB // 5 DB, 4 WB  
<sup>5</sup>Heating at -5°F (Indoor // Outdoor) °F 70 DB, 60 WB // -5 DB, -6 WB  
 Conditions  
<sup>6</sup>Indoor units receive power from outdoor units through field-supplied interconnected wiring.  
<sup>7</sup>Applications should be restricted to comfort cooling only, equipment cooling applications are not recommended for low ambient temperature conditions.

# SVZ Model

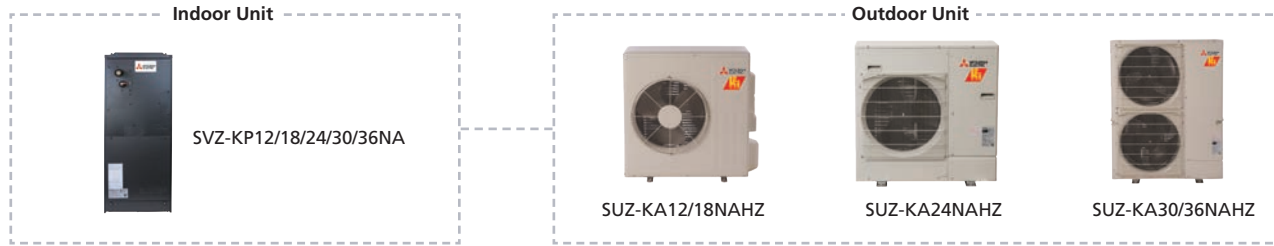

\* To confirm compatibility with the MXZ Model multi-zone system, refer to MXZ Model page.

Indoor Unit				SVZ-KP12NA	SVZ-KP18NA	SVZ-KP24NA	SVZ-KP30NA	SVZ-KP36NA
Outdoor Unit				SUZ-KA12NAHZ	SUZ-KA18NAHZ	SUZ-KA24NAHZ	SUZ-KA30NAHZ	SUZ-KA36NAHZ
Cooling	Capacity	Rated <sup>1</sup>	BTU/H	12,000	18,000	24,000	27,000	36,000
	Capacity Range	Min-Max	BTU/H	5,600–12,000	9,360–18,000	8,800–24,000	13,400–27,000	14,200–36,000
	Power Input	Rated <sup>1</sup>	W	860	1,440	2,420	2,100	3,760
	Moisture Removal	Pints/h		0.8	1.1	4.7	4.1	8.4
	Sensible Heat Factor			0.920	0.930	0.780	0.830	0.740
Heating	Capacity at 47°F	Rated <sup>2</sup>	BTU/H	15,000	21,600	23,000	32,000	37,000
	Capacity Range	Min-Max	BTU/H	7,700–18,000	8,800–28,000	9,400–28,800	13,000–34,000	13,800–40,000
	Power Input at 47°F	Rated <sup>2</sup>	W	1,130	1,880	2,140	2,400	3,280
	Capacity at 17°F	Rated <sup>3</sup>	BTU/H	8,900	14,300	19,200	21,400	32,800
	Capacity at 5°F	Max <sup>4</sup>	BTU/H	15,000	21,600	23,000	32,000	37,000
	Capacity at -5°F	Max <sup>5</sup>	BTU/H	—	—	—	—	—
Efficiency	SEER			19.0	18.4	16.0	15.0	16.0
	EER			13.9	12.5	9.9	12.5	9.5
	HSPF			10.2	10.4	9.2	9.0	9.0
	COP			3.8	3.3	3.1	3.9	3.3
	ENERGY STAR® Certified			Yes	Yes	No	Yes	No
Indoor Unit	Air Flow Rate - Cooling (Quiet-Lo-Med-Hi-SHi)	Dry	CFM	278–381–448	471–573–675	515–625–735	613–744–875	767–910–910
	Air Flow Rate - Cooling (Quiet-Lo-Med-Hi-SHi)	Wet	CFM	—	—	—	—	—
	Air Flow Rate - Heating (Quiet-Lo-Med-Hi-SHi)	Dry	CFM	278–381–448	471–573–675	515–625–735	613–744–875	767–910–910
	Sound Pressure Level (Quiet-Lo-Med-Hi-SHi)	Cooling	dB(A)	29–36–39	33–36–41	33–36–41	32–37–41	35–40–42
	Sound Pressure Level (Quiet-Lo-Med-Hi-SHi)	Heating	dB(A)	29–36–39	33–36–41	33–36–41	32–37–41	35–40–42
	External Static Pressure		In. W.G.	0.30–0.5–0.8	0.30–0.5–0.8	0.30–0.5–0.8	0.30–0.5–0.8	0.30–0.5–0.8
	Condensate Lift Mechanism	Max Distance	In. [mm]	—	—	—	—	—
		H	In. [mm]	34-5/8 [880]	39-13/16 [1011]	39-13/16 [1011]	43-3/4 [1111]	43-3/4 [1111]
	Dimensions	W	In. [mm]	33-1/16 [840]	17 [432]	17 [432]	21 [533]	21 [533]
		D	In. [mm]	13 [330]	21-5/8 [549]	21-5/8 [549]	21-5/8 [549]	21-5/8 [549]
Weight	lbs [kg]		93 [42]	93 [42]	119 [54]	119 [54]	119 [54]	
Outdoor Unit	MCA	A		14.0	17.0	17.0	24.0	26.0
	MOCP	A		24	31	27	40	42
	Dimensions	H	In. [mm]	34-5/8 [880]	34-5/8 [880]	37-1/8 [943]	52-11/16 [1338]	52-11/16 [1338]
		W	In. [mm]	33-1/16 [840]	33-1/16 [840]	37-13/32 [950]	41-5/16 [1050]	41-5/16 [1050]
	Weight	D	In. [mm]	13 [330]	13 [330]	14-3/16 [360]	14-3/16 [360]	14-3/16 [360]
		lbs [kg]		129 [58.5]	131 [59.5]	190 [86]	261 [118]	261 [118]
	Air Flow Rate (Cooling/Heating)	CFM		1,691/1,691	2,020/1,930	800/800	590/680	590/680
Sound Pressure Level	Cooling	dB(A)	54	55	52	52	52	
	Heating	dB(A)	55	55	53	53	53	
Piping	Diameter	Gas (O.D.)	In. [mm]	3/8 [9.52]	1/2 [12.7]	5/8 [15.88]	5/8 [15.88]	5/8 [15.88]
		Liquid (O.D)	In. [mm]	1/4 [6.35]	1/4 [6.35]	3/8 [9.52]	3/8 [9.52]	3/8 [9.52]
		Indoor Drain	In. [mm]	3/4 [19.05]	3/4 [19.05]	3/4 [19.05]	3/4 [19.05]	3/4 [19.05]
	Max. Length	ft [m]		65 [20]	100 [30]	165 [50]	245 [75]	245 [75]
Max. Height	ft [m]		40 [12]	50 [15]	100 [30]	100 [30]	100 [30]	
Electrical	Outdoor-Indoor <sup>6</sup>	V, ph, Hz		208/230, 1, 60	208/230, 1, 60	208/230, 1, 60	208/230, 1, 60	208/230, 1, 60
	Recommended Breaker Size	A		15	20	25	35	35
Refrigerant Type				R410A	R410A	R410A	R410A	R410A
Guaranteed Temperature Operation Range	Cooling <sup>7</sup>	°F DB [°C DB]		0 to 115 [-10.0 to 46.0]	0 to 115 [-10.0 to 46.0]	0 to 115 [-10.0 to 46.0]	0 to 115 [-10.0 to 46.0]	0 to 115 [-10.0 to 46.0]
	Heating	°F DB [°C DB]		-13 to 75 [-25.0 to 24.0]	-13 to 75 [-25.0 to 24.0]	-13 to 75 [-25.0 to 24.0]	-13 to 75 [-25.0 to 24.0]	-13 to 75 [-25.0 to 24.0]

Notes:  
AHRI Rated Conditions  
(Rated data is determined at a fixed compressor speed)

<sup>1</sup>Cooling (Indoor // Outdoor)  
<sup>2</sup>Heating at 47°F (Indoor // Outdoor)  
<sup>3</sup>Heating at 17°F (Indoor // Outdoor)  
<sup>4</sup>Heating at 5°F (Indoor // Outdoor)  
<sup>5</sup>Heating at -5°F (Indoor // Outdoor)

°F 80 DB, 67 WB // 95 DB, 75 WB  
°F 70 DB, 60 WB // 47 DB, 43 WB  
°F 70 DB, 60 WB // 17 DB, 15 WB  
°F 70 DB, 60 WB // 5 DB, 4 WB  
°F 70 DB, 60 WB // -5 DB, -6 WB

Conditions

<sup>6</sup>Indoor units receive power from outdoor units through field-supplied interconnected wiring.

<sup>7</sup>Applications should be restricted to comfort cooling only; equipment cooling applications are not recommended for low ambient temperature conditions.



# SLZ Model

Four-way Ceiling Cassette



## Flexibility

The attractive SLZ Model ceiling cassette units offer a slim width and a four-way air outlet. The size and shape are a perfect match for ceilings made using 2'x2' construction and its light weight package makes installation easy.

The compact body matches 2'x2' ceiling construction specifications.

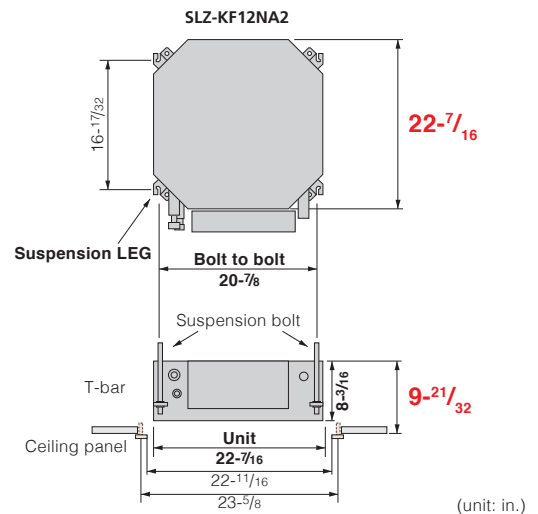
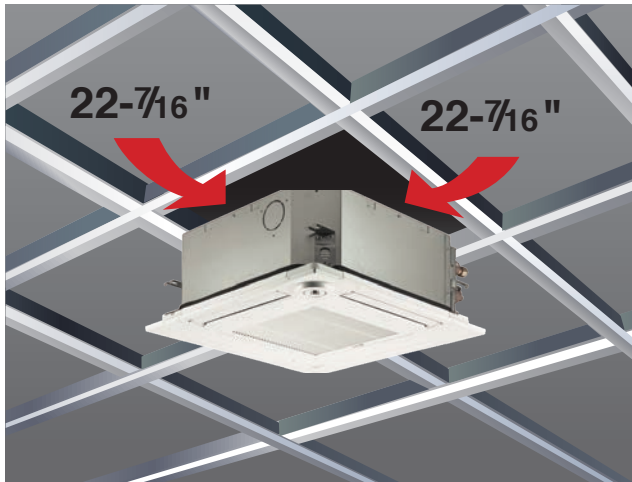

\* Access door is required

## Fresh-air Intake

A duct hole is provided in the main body, making it possible to intake fresh air from outside.

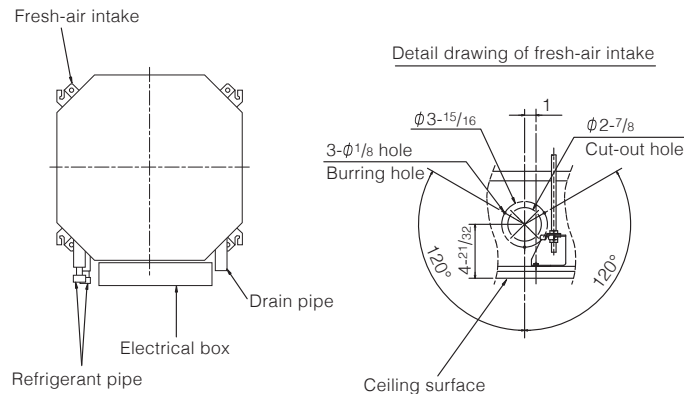

Static pressure: P [in. W.G. x 10<sup>-2</sup>]

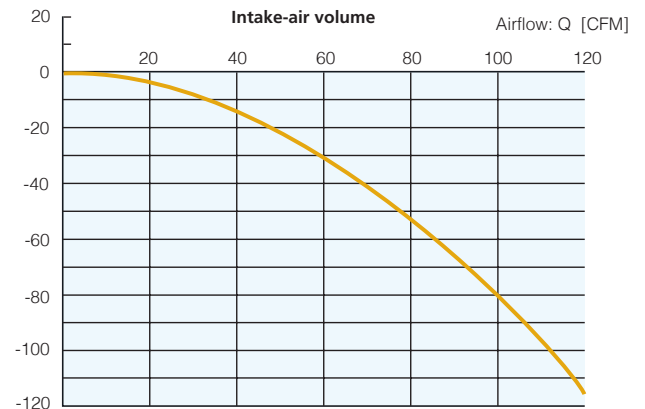

Note: Fresh-air intake amount should be 20% or less of whole air amount to prevent dew dripping. Booster fan required.

# SLZ-KF Model

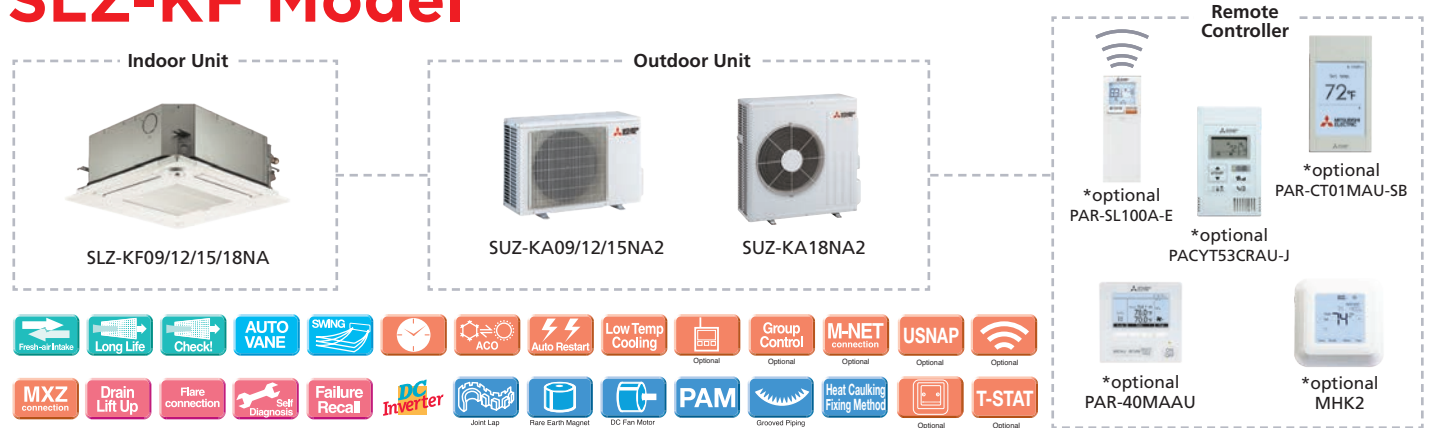

SLP-18FAU (standard grille) SLP-18FAEU (3D i-see Sensor® grille)

Indoor Unit				SLZ-KF09NA	SLZ-KF12NA	SLZ-KF15NA	SLZ-KF18NA
Outdoor Unit				SUZ-KA09NA2	SUZ-KA12NA2	SUZ-KA15NA2	SUZ-KA18NA2
Cooling	Capacity	Rated <sup>1</sup>	BTU/H	9,000	12,000	14,100	17,700
	Capacity Range	Min-Max	BTU/H	3,600-9,000	3,900-12,000	5,100-14,100	6,100-17,700
	Power Input	Rated <sup>1</sup>	W	670	900	1,150	1,410
	Moisture Removal	Pints/h		1.0	2.8	3.2	4.7
	Sensible Heat Factor			0.870	0.740	0.750	0.710
Heating	Capacity at 47°F	Rated <sup>2</sup>	BTU/H	11,000	13,000	18,000	19,700
	Capacity Range	Min-Max	BTU/H	4,010-12,000	4,800-13,000	5,100-19,100	8,400-20,900
	Power Input at 47°F	Rated <sup>2</sup>	W	4,010	4,800	5,100	8,400
	Capacity at 17°F	Rated <sup>3</sup>	BTU/H	6,900	8,900	11,900	12,900
	Capacity at 5°F	Max <sup>4</sup>	BTU/H	6,900	8,900	11,900	12,900
Efficiency	Capacity at -5°F	Max <sup>5</sup>	BTU/H	5,600	6,100	8,900	9,800
	SEER			22.4	22.0	19.8	20.7
	EER			13.4	13.3	12.2	12.5
	HSPF			12.2	11.4	11.2	11.6
	COP			3.9	2.9	3.0	3.1
Indoor Unit	ENERGY STAR® Certified			Yes	Yes	No	Yes
	Air Flow Rate - Cooling (Quiet-Lo-Med-Hi-SHi)	Dry	CFM	230-265-300	230-265-335	245-315-405	300-420-475
	Air Flow Rate - Cooling (Quiet-Lo-Med-Hi-SHi)	Wet	CFM	207-239-270	207-252-302	221-284-365	270-378-429
	Air Flow Rate - Heating (Quiet-Lo-Med-Hi-SHi)	Dry	CFM	230-265-335	230-265-335	245-315-405	300-420-475
	Sound Pressure Level (Quiet-Lo-Med-Hi-SHi)	Cooling	dB(A)	25-28-31	25-30-34	27-34-39	32-40-43
	Sound Pressure Level (Quiet-Lo-Med-Hi-SHi)	Heating	dB(A)	25-28-31	25-30-34	27-34-39	32-40-43
	External Static Pressure		In. W.G.	—	—	—	—
	Condensate Lift Mechanism	Max Distance	In. [mm]	33 [850]	33 [850]	33 [850]	33 [850]
		H	In. [mm]	9-21/32 [245]	9-21/32 [245]	9-21/32 [245]	9-21/32 [245]
	Dimensions	W	In. [mm]	22-7/16 [570]	22-7/16 [570]	22-7/16 [570]	22-7/16 [570]
D		In. [mm]	22-7/16 [570]	22-7/16 [570]	22-7/16 [570]	22-7/16 [570]	
Weight		lbs [kg]	31 [13.9]	31 [13.9]	31 [13.9]	31 [13.9]	
Outdoor Unit	MCA	A		9.0	9.0	10.0	14.0
	MOCP	A		15	16	18	24
	Dimensions	H	In. [mm]	21-5/8 [550]	21-5/8 [550]	21-5/8 [550]	34-5/8 [880]
		W	In. [mm]	31-1/2 [800]	31-1/2 [800]	31-1/2 [800]	33-1/16 [840]
		D	In. [mm]	11-1/4 [285]	11-1/4 [285]	11-1/4 [285]	13 [330]
	Weight	lbs [kg]		81 [37]	81 [37]	81 [37]	127 [58]
	Air Flow Rate (Cooling/Heating)	CFM		1228/1172	1228/1172	1243/1229	1691/1691
	Sound Pressure Level	Cooling	dB(A)	48	49	49	54
Heating		dB(A)	50	51	51	55	
Piping	Diameter	Gas (O.D.)	In. [mm]	3/8 [9.52]	3/8 [9.52]	1/2 [12.7]	1/2 [12.7]
		Liquid (O.D)	In. [mm]	1/4 [6.35]	1/4 [6.35]	1/4 [6.35]	1/4 [6.35]
		Indoor Drain	In. [mm]	1-1/4 [32]	1-1/4 [32]	1-1/4 [32]	1-1/4 [32]
	Max. Length	ft [m]		65 [20]	65 [20]	65 [20]	100 [30]
Max. Height	ft [m]		40 [12]	40 [12]	40 [12]	50 [15]	
Electrical	Outdoor-Indoor <sup>6</sup>	V, ph, Hz		208/230, 1, 60	208/230, 1, 60	208/230, 1, 60	208/230, 1, 60
	Recommended Breaker Size	A		15	15	15	15
Refrigerant Type				R410A	R410A	R410A	R410A
Guaranteed Temperature Operation Range	Cooling <sup>7</sup>	°F DB [°C DB]		14 to 115 [-10 to 46]	14 to 115 [-10 to 46]	14 to 115 [-10 to 46]	14 to 115 [-10 to 46]
	Heating	°F DB [°C DB]		-4 to -75 [-20 to 24]	-4 to -75 [-20 to 24]	-4 to -75 [-20 to 24]	-4 to -75 [-20 to 24]

Notes:  
AHRI Rated Conditions  
(Rated data is determined at a fixed compressor speed)

<sup>1</sup>Cooling (Indoor // Outdoor)

<sup>2</sup>Heating at 47°F (Indoor // Outdoor)

<sup>3</sup>Heating at 17°F (Indoor // Outdoor)

<sup>4</sup>Heating at 5°F (Indoor // Outdoor)

<sup>5</sup>Heating at -5°F (Indoor // Outdoor)

°F 80 DB, 67 WB // 95 DB, 75 WB

°F 70 DB, 60 WB // 47 DB, 43 WB

°F 70 DB, 60 WB // 17 DB, 15 WB

°F 70 DB, 60 WB // 5 DB, 4 WB

°F 70 DB, 60 WB // -5 DB, -6 WB

Conditions

<sup>6</sup>Indoor units receive power from outdoor units through field-supplied interconnected wiring.

<sup>7</sup>Applications should be restricted to comfort cooling only; equipment cooling applications are not recommended for low ambient temperature conditions.

# SLZ-KF Model



SLP-18FAU (standard grille) SLP-18FAEU (3D i-see Sensor® grille) 

Indoor Unit				SLZ-KF09NA	SLZ-KF12NA	SLZ-KF15NA	SLZ-KF18NA
Outdoor Unit				SUZ-KA09NAHZ	SUZ-KA12NAHZ	SUZ-KA15NAHZ	SUZ-KA18NAHZ
Cooling	Capacity	Rated <sup>1</sup>	BTU/H	9,000	12,000	13,700	16,800
	Capacity Range	Min-Max	BTU/H	4,800-9,000	5,070-12,000	8,500-13,700	9,010-16,800
	Power Input	Rated <sup>1</sup>	W	600	940	1,095	1,340
	Moisture Removal	Pints/h		1.9	3.1	3.4	4.2
	Sensible Heat Factor			0.770	0.710	0.720	0.720
Heating	Capacity at 47°F	Rated <sup>2</sup>	BTU/H	11,000	13,800	16,400	18,800
	Capacity Range	Min-Max	BTU/H	7,400-13,200	7,800-14,500	8,300-19,000	8,300-20,000
	Power Input at 47°F	Rated <sup>2</sup>	W	820	1,170	1,830	2,020
	Capacity at 17°F	Rated <sup>3</sup>	BTU/H	6,300	8,300	9,700	12,100
		Max	BTU/H	11,000	13,800	16,400	18,800
	Capacity at 5°F	Max <sup>4</sup>	BTU/H	11,000	13,800	16,400	18,800
Efficiency	Capacity at -5°F	Max <sup>5</sup>	BTU/H	—	—	—	—
	SEER			20.2	20.3	17.7	19.0
	EER			15.0	12.7	12.5	12.5
	HSPF			10.0	10.0	9.0	9.4
	COP			3.9	3.4	2.6	2.7
	ENERGY STAR® Certified		Yes	Yes	Yes	Yes	
Indoor Unit	Air Flow Rate - Cooling (Quiet-Lo-Med-Hi-SHi)	Dry	CFM	230-265-300	230-265-335	245-315-405	300-420-475
	Air Flow Rate - Cooling (Quiet-Lo-Med-Hi-SHi)	Wet	CFM	207-239-270	207-252-302	221-284-365	270-378-429
	Air Flow Rate - Heating (Quiet-Lo-Med-Hi-SHi)	Dry	CFM	230-265-335	230-265-335	245-315-405	300-420-475
	Sound Pressure Level (Quiet-Lo-Med-Hi-SHi)	Cooling	dB(A)	25-28-31	25-30-34	27-34-39	32-40-43
	Sound Pressure Level (Quiet-Lo-Med-Hi-SHi)	Heating	dB(A)	25-28-31	25-30-34	27-34-39	32-40-43
	External Static Pressure		In. W.G.	—	—	—	—
	Condensate Lift Mechanism	Max Distance	In. [mm]	33 [850]	33 [850]	33 [850]	33 [850]
	Dimensions	H	In. [mm]	9-21/32 [245]	9-21/32 [245]	9-21/32 [245]	9-21/32 [245]
		W	In. [mm]	22-7/16 [570]	22-7/16 [570]	22-7/16 [570]	22-7/16 [570]
		D	In. [mm]	22-7/16 [570]	22-7/16 [570]	22-7/16 [570]	22-7/16 [570]
Weight	lbs [kg]		31 [13.9]	31 [13.9]	31 [13.9]	31 [13.9]	
Outdoor Unit	MCA	A		14.0	14.0	17.0	17.0
	MOCP	A		24	24	31	31
	Dimensions	H	In. [mm]	34-5/8 [880]	34-5/8 [880]	34-5/8 [880]	34-5/8 [880]
		W	In. [mm]	38-1/16 [840]	33-1/16 [840]	33-1/16 [840]	33-1/16 [840]
		D	In. [mm]	13 [330]	13 [330]	13 [330]	13 [330]
	Weight	lbs [kg]		129 [58.5]	129 [58.5]	131 [59.5]	131 [59.5]
	Air Flow Rate (Cooling/Heating)	CFM		1,691/1,691	1,691/1,691	2,020/1,930	2,020/1,930
Sound Pressure Level	Cooling	dB(A)	54	54	55	55	
	Heating	dB(A)	55	55	55	55	
Piping	Diameter	Gas (O.D.)	In. [mm]	3/8 [9.52]	3/8 [9.52]	1/2 [12.7]	1/2 [12.7]
		Liquid (O.D)	In. [mm]	1/4 [6.35]	1/4 [6.35]	1/4 [6.35]	1/4 [6.35]
		Indoor Drain	In. [mm]	1-1/4 [32]	1-1/4 [32]	1-1/4 [32]	1-1/4 [32]
	Max. Length	ft [m]		65 [20]	65 [20]	100 [30]	100 [30]
Max. Height	ft [m]		40 [12]	40 [12]	40 [12]	50 [15]	
Electrical	Outdoor-Indoor <sup>6</sup>	V, ph, Hz		208/230, 1, 60	208/230, 1, 60	208/230, 1, 60	208/230, 1, 60
	Recommended Breaker Size	A		15	15	20	20
Refrigerant Type				R410A	R410A	R410A	R410A
Guaranteed Temperature Operation Range	Cooling <sup>7</sup>	°F DB [°C DB]		14 to 115 [-10 to 46]	14 to 115 [-10 to 46]	14 to 115 [-10 to 46]	14 to 115 [-10 to 46]
	Heating	°F DB [°C DB]		-13 to -75 [-25 to 24]	-13 to -75 [-25 to 24]	-13 to -75 [-25 to 24]	-13 to -75 [-25 to 24]

Notes:  
AHR1 Rated Conditions  
(Rated data is determined at a fixed compressor speed)

<sup>1</sup>Cooling (Indoor // Outdoor) °F 80 DB, 67 WB // 95 DB, 75 WB  
<sup>2</sup>Heating at 47°F (Indoor // Outdoor) °F 70 DB, 60 WB // 47 DB, 43 WB  
<sup>3</sup>Heating at 17°F (Indoor // Outdoor) °F 70 DB, 60 WB // 17 DB, 15 WB  
<sup>4</sup>Heating at 5°F (Indoor // Outdoor) °F 70 DB, 60 WB // 5 DB, 4 WB  
<sup>5</sup>Heating at -5°F (Indoor // Outdoor) °F 70 DB, 60 WB // -5 DB, -6 WB

Conditions  
<sup>6</sup>Indoor units receive power from outdoor units through field-supplied interconnected wiring.  
<sup>7</sup>Applications should be restricted to comfort cooling only; equipment cooling applications are not recommended for low ambient temperature conditions.



# SEZ Model

Low Static Horizontal-ducted



## Compact Ceiling-Concealed Units

Only the intake-air grille and outlet vents are visible when using the SEZ Model ceiling-concealed indoor unit. The compact design requires minimal space and installs in buildings with lowered ceilings or attics.

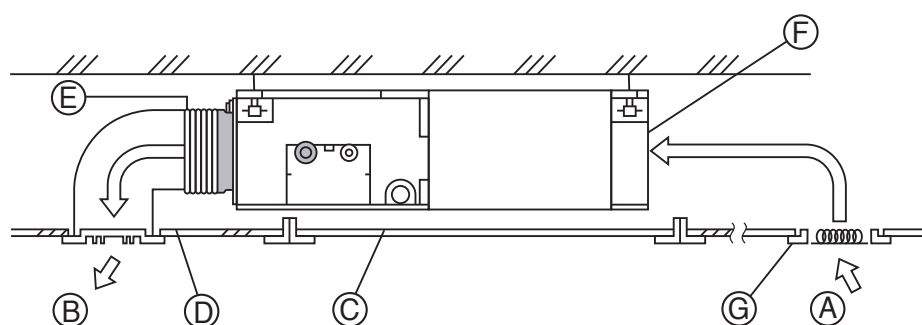

- Ⓐ Air inlet
- Ⓑ Air outlet
- Ⓒ Access door
- Ⓓ Ceiling surface
- Ⓔ Canvas duct
- Ⓕ Air filter
- Ⓖ Inlet grille

## Selection of Fan Speeds and Static Pressure Levels

Three fan speed settings (Low, Medium, and High) and four static pressure levels are available for all capacities.

### Sound Levels

	Low	Medium	High
09	23 dB(A)	26 dB(A)	30 dB(A)
12	23 dB(A)	28 dB(A)	33 dB(A)
15	30 dB(A)	34 dB(A)	37 dB(A)
18	30 dB(A)	34 dB(A)	38 dB(A)

### Static Pressure Levels

SEZ-KD09-18NA4

0.02-0.06-0.14-0.20 In.W.G.

# SEZ-KD Model

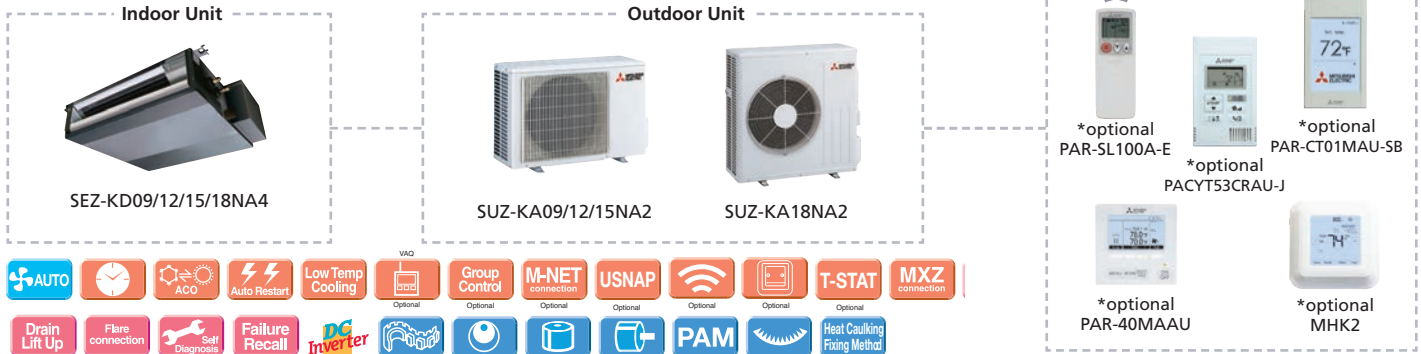

Indoor Unit				SEZ-KD09NA4R1	SEZ-KD12NA4R1	SEZ-KD15NA4R1	SEZ-KD18NA4R1	
Outdoor Unit				SUZ-KA09NA2	SUZ-KA12NA2	SUZ-KA15NA2	SUZ-KA18NA2	
Cooling	Capacity	Rated <sup>1</sup>	BTU/H	9,000	12,000	15,000	18,000	
	Capacity Range	Min-Max	BTU/H	3,900-9,000	4,000-12,000	5,200-15,000	6,100-18,000	
	Power Input	Rated <sup>1</sup>	W	700	930	1,150	1,310	
	Moisture Removal	Pints/h		1.5	1.9	1.9	2.8	
	Sensible Heat Factor			0.820	0.820	0.860	0.820	
Heating	Capacity at 47°F	Rated <sup>2</sup>	BTU/H	12,000	15,000	18,000	21,600	
	Capacity Range	Min-Max	BTU/H	4,200-12,800	4,800-16,800	5,000-21,600	8,100-25,600	
	Power Input at 47°F	Rated <sup>2</sup>	W	1,100	1,330	1,440	1,580	
	Capacity at 17°F	Rated <sup>3</sup>	BTU/H	7,600	10,000	11,700	13,900	
		Max	BTU/H	6,700	9,000	11,900	13,100	
	Capacity at 5°F	Max <sup>4</sup>	BTU/H	6,000	7,900	10,000	12,000	
Efficiency	SEER			18.8	20.5	19.0	22.0	
	EER			12.8	12.9	13.0	13.7	
	HSPF			11.0	12.4	11.4	13.1	
	COP			3.1	3.3	3.6	4.0	
	ENERGY STAR® Certified			Yes	Yes	Yes	Yes	
Indoor Unit	Air Flow Rate - Cooling (Quiet-Lo-Med-Hi-SHi)	Dry	CFM	194-247-317	247-317-388	353-441-529	423-529-635	
	Air Flow Rate - Cooling (Quiet-Lo-Med-Hi-SHi)	Wet	CFM	174-222-285	222-285-349	317-396-476	381-476-572	
	Air Flow Rate - Heating (Quiet-Lo-Med-Hi-SHi)	Dry	CFM	194-247-317	247-317-388	353-441-529	423-529-635	
	Sound Pressure Level (Quiet-Lo-Med-Hi-SHi)	Cooling	dB(A)	23-26-30	23-28-33	30-34-37	30-34-38	
	Sound Pressure Level (Quiet-Lo-Med-Hi-SHi)	Heating	dB(A)	23-26-30	23-28-33	30-34-37	30-34-38	
	External Static Pressure		In. W.G.	0.02-0.06-0.14-0.2	0.02-0.06-0.14-0.2	0.02-0.06-0.14-0.2	0.02-0.06-0.14-0.2	
	Dimensions	Condensate Lift Mechanism	Max Distance	In. [mm]	2121/32 [550]	21-21/32 [550]	21-21/32 [550]	21-21/32 [550]
			H	In. [mm]	7-7/8 [200]	7-7/8 [200]	7-7/8 [200]	7-7/8 [200]
		W	In. [mm]	31-1/8 [790]	39 [990]	39 [990]	46-7/8 [1190]	
			D	In. [mm]	27-9/16 [700]	27-9/16 [700]	27-9/16 [700]	27-9/16 [700]
Outdoor Unit	Weight	lbs [kg]		42 [19.0]	50 [22.0]	54 [24.0]	62 [28.0]	
	MCA	A		9.0	9.0	10.0	14.0	
	MOCP	A		15	16	18	24	
	Dimensions	H	In. [mm]		21-5/8 [550]	21-5/8 [550]	21-5/8 [550]	34-5/8 [880]
		W	In. [mm]		31-1/2 [800]	31-1/2 [800]	31-1/2 [800]	33-1/16 [840]
		D	In. [mm]		11-1/4 [285]	11-1/4 [285]	11-1/4 [285]	13 [330]
	Weight	lbs [kg]		81 [37]	81 [37]	81 [37]	127 [58]	
Air Flow Rate (Cooling/Heating)	CFM		1228/1172	1228/1172	1243/1229	1691/1691		
Sound Pressure Level	Cooling	dB(A)		48	49	49	54	
	Heating	dB(A)		50	51	51	55	
Piping	Diameter	Gas (O.D.)	In. [mm]	3/8 [9.52]	3/8 [9.52]	1/2 [12.7]	1/2 [12.7]	
		Liquid (O.D.)	In. [mm]	1/4 [6.35]	1/4 [6.35]	1/4 [6.35]	1/4 [6.35]	
		Indoor Drain	In. [mm]	1-1/4 [32]	1-1/4 [32]	1-1/4 [32]	1-1/4 [32]	
	Max. Length	ft [m]		65 [20]	65 [20]	65 [20]	100 [30]	
Max. Height	ft [m]		40 [12]	40 [12]	40 [12]	50 [15]		
Electrical	Outdoor-Indoor <sup>6</sup>	V, ph, Hz		208/230, 1, 60	208/230, 1, 60	208/230, 1, 60	208/230, 1, 60	
	Recommended Breaker Size	A		15	15	15	15	
Refrigerant Type				R410A	R410A	R410A	R410A	
Guaranteed Temperature Operation Range	Cooling <sup>7</sup>	°F DB [°C DB]		14 to 115 [-10.0 to 46.0]	14 to 115 [-10.0 to 46.0]	14 to 115 [-10.0 to 46.0]	14 to 115 [-10.0 to 46.0]	
	Heating	°F DB [°C DB]		-4 to -75 [-20.0 to 24.0]	-4 to -75 [-20.0 to 24.0]	-4 to -75 [-20.0 to 24.0]	-4 to -75 [-20.0 to 24.0]	

Notes:  
 AHRI Rated Conditions  
 (Rated data is determined at a fixed compressor speed)

<sup>1</sup>Cooling (Indoor // Outdoor) °F 80 DB, 67 WB // 95 DB, 75 WB  
<sup>2</sup>Heating at 47°F (Indoor // Outdoor) °F 70 DB, 60 WB // 47 DB, 43 WB  
<sup>3</sup>Heating at 17°F (Indoor // Outdoor) °F 70 DB, 60 WB // 17 DB, 15 WB  
<sup>4</sup>Heating at 5°F (Indoor // Outdoor) °F 70 DB, 60 WB // 5 DB, 4 WB  
<sup>5</sup>Heating at -5°F (Indoor // Outdoor) °F 70 DB, 60 WB // -5 DB, -6 WB

Conditions  
<sup>6</sup>Indoor units receive power from outdoor units through field-supplied interconnected wiring.  
<sup>7</sup>Applications should be restricted to comfort cooling only; equipment cooling applications are not recommended for low ambient temperature conditions.

# SEZ-KD Model

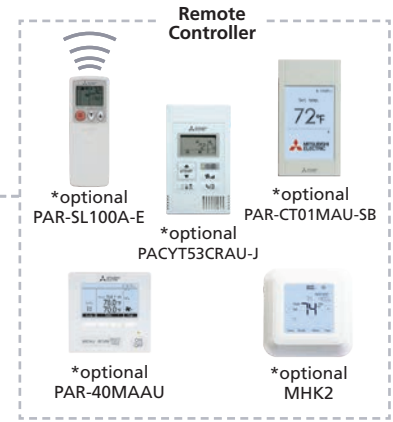
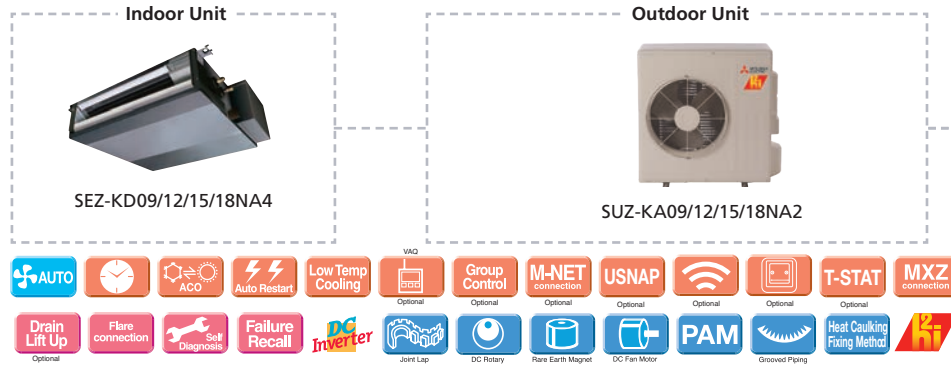

Indoor Unit				SEZ-KD09NA4R1	SEZ-KD12NA4R1	SEZ-KD15NA4R1	SEZ-KD18NA4R1	
Outdoor Unit				SUZ-KA09NAHZ	SUZ-KA12NAHZ	SUZ-KA15NAHZ	SUZ-KA18NAHZ	
Cooling	Capacity	Rated <sup>1</sup>	BTU/H	9,000	12,000	15,000	18,000	
	Capacity Range	Min-Max	BTU/H	4,500-9,000	5,210-12,000	9,000-15,000	9,200-18,000	
	Power Input	Rated <sup>1</sup>	W	690	920	1,200	1,370	
	Moisture Removal	Pints/h		1.7	2.5	2.8	2.0	
	Sensible Heat Factor			0.790	0.760	0.800	0.870	
Heating	Capacity at 47°F	Rated <sup>2</sup>	BTU/H	12,500	15,000	18,000	21,600	
	Capacity Range	Min-Max	BTU/H	8,100-13,300	7,700-18,000	8,600-22,400	8,800-28,000	
	Power Input at 47°F	Rated <sup>2</sup>	W	1,300	1,120	1,920	1,840	
	Capacity at 17°F	Rated <sup>3</sup>	BTU/H	8,700	9,000	12,200	14,200	
		Max	BTU/H	12,500	15,000	18,000	21,600	
	Capacity at 5°F	Max <sup>4</sup>	BTU/H	12,500	15,000	18,000	21,600	
Efficiency	SEER			17.3	19.0	17.3	19.1	
	EER			13.0	13.0	12.5	13.1	
	HSPF			9.8	10.2	9.5	10.9	
	COP			2.8	3.9	2.7	3.4	
	ENERGY STAR® Certified			Yes	Yes	Yes	Yes	
Indoor Unit	Air Flow Rate - Cooling (Quiet-Lo-Med-Hi-SHi)	Dry	CFM	194-247-317	247-317-388	353-441-529	423-529-635	
	Air Flow Rate - Cooling (Quiet-Lo-Med-Hi-SHi)	Wet	CFM	174-222-285	222-285-349	317-396-476	381-476-572	
	Air Flow Rate - Heating (Quiet-Lo-Med-Hi-SHi)	Dry	CFM	194-247-317	247-317-388	353-441-529	423-529-635	
	Sound Pressure Level (Quiet-Lo-Med-Hi-SHi)	Cooling	dB(A)	23-26-30	23-28-33	30-34-37	30-34-38	
	Sound Pressure Level (Quiet-Lo-Med-Hi-SHi)	Heating	dB(A)	23-26-30	23-28-33	30-34-37	30-34-38	
	External Static Pressure		In. W.G.	0.02-0.06-0.14-0.2	0.02-0.06-0.14-0.2	0.02-0.06-0.14-0.2	0.02-0.06-0.14-0.2	
	Condensate Lift Mechanism	Max Distance	In. [mm]		2121/32 [550]	21-21/32 [550]	21-21/32 [550]	21-21/32 [550]
			H	In. [mm]	7-7/8 [200]	7-7/8 [200]	7-7/8 [200]	7-7/8 [200]
			W	In. [mm]	31-1/8 [790]	39 [990]	39 [990]	46-7/8 [1190]
			D	In. [mm]	27-9/16 [700]	27-9/16 [700]	27-9/16 [700]	27-9/16 [700]
Weight		lbs [kg]		42 [19.0]	50 [22.0]	54 [24.0]	62 [28.0]	
Outdoor Unit	MCA	A		14.0	14.0	17.0	17.0	
	MOCP	A		24	24	31	31	
	Dimensions	H	In. [mm]		34-5/8 [880]	34-5/8 [880]	34-5/8 [880]	34-5/8 [880]
		W	In. [mm]		38-1/16 [840]	33-1/16 [840]	33-1/16 [840]	33-1/16 [840]
		D	In. [mm]		13 [330]	13 [330]	13 [330]	13 [330]
	Weight		lbs [kg]		129 [58.5]	129 [58.5]	131 [59.5]	131 [59.5]
	Air Flow Rate (Cooling/Heating)		CFM		1,691/1,691	1,691/1,691	2,020/1,930	2,020/1,930
	Sound Pressure Level	Cooling	dB(A)		54	54	55	55
Heating		dB(A)		55	55	55	55	
Piping	Diameter	Gas (O.D.)	In. [mm]	3/8 [9.52]	3/8 [9.52]	1/2 [12.7]	1/2 [12.7]	
		Liquid (O.D)	In. [mm]	1/4 [6.35]	1/4 [6.35]	1/4 [6.35]	1/4 [6.35]	
		Indoor Drain	In. [mm]	1-1/4 [32]	1-1/4 [32]	1-1/4 [32]	1-1/4 [32]	
Max. Length		ft [m]		65 [20]	65 [20]	65 [20]	100 [30]	
Max. Height		ft [m]		40 [12]	40 [12]	40 [12]	50 [15]	
Electrical	Outdoor-Indoor <sup>6</sup>	V, ph, Hz		208/230, 1, 60	208/230, 1, 60	208/230, 1, 60	208/230, 1, 60	
	Recommended Breaker Size	A		15	15	20	20	
Refrigerant Type				R410A	R410A	R410A	R410A	
Guaranteed Temperature Operation Range	Cooling <sup>7</sup>	°F DB [°C DB]		0 to 115 [-10.0 to 46.0]	0 to 115 [-10.0 to 46.0]	0 to 115 [-10.0 to 46.0]	0 to 115 [-10.0 to 46.0]	
	Heating	°F DB [°C DB]		-13 to 75 [-25.0 to 24.0]	-13 to 75 [-25.0 to 24.0]	-13 to 75 [-25.0 to 24.0]	-13 to 75 [-25.0 to 24.0]	

Notes:  
 AHRI Rated Conditions (Rated data is determined at a fixed compressor speed)  
<sup>1</sup>Cooling (Indoor // Outdoor) °F 80 DB, 67 WB // 95 DB, 75 WB  
<sup>2</sup>Heating at 47°F (Indoor // Outdoor) °F 70 DB, 60 WB // 47 DB, 43 WB  
<sup>3</sup>Heating at 17°F (Indoor // Outdoor) °F 70 DB, 60 WB // 17 DB, 15 WB  
<sup>4</sup>Heating at 5°F (Indoor // Outdoor) °F 70 DB, 60 WB // 5 DB, 4 WB  
<sup>5</sup>Heating at -5°F (Indoor // Outdoor) °F 70 DB, 60 WB // -5 DB, -6 WB

Conditions  
<sup>6</sup>Indoor units receive power from outdoor units through field-supplied interconnected wiring.  
<sup>7</sup>Applications should be restricted to comfort cooling only; equipment cooling applications are not recommended for low ambient temperature conditions.

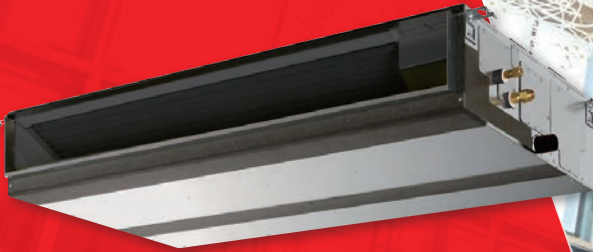

# PEAD Model

Mid Static Horizontal-ducted



The thin, ceiling-concealed indoor units of this model are the perfect answer for the air conditioning needs of buildings with minimum ceiling installation space and wide-ranging external static pressure. Energy-saving efficiency has been improved, reducing electricity consumption and contributing to a further reduction in operating cost.

## Compact Indoor Units

The height is only 9-7/8" for all sizes of this model ranging from 12 to 42 KBTU/H. Its compact size allows for the unit installations in low ceilings with minimal clearance space.

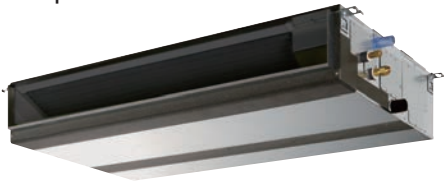

## External Static Pressure

External static pressure conversion can be set up to five settings. Capable of being set to a maximum of 0.60 In.W.G., units are applicable to a wide range of building types.

Model	12	18	24	30	36	42
PEAD-AA7	0.14-0.20-0.28-0.40-0.60 In. W.G.					

## High Energy Efficiency

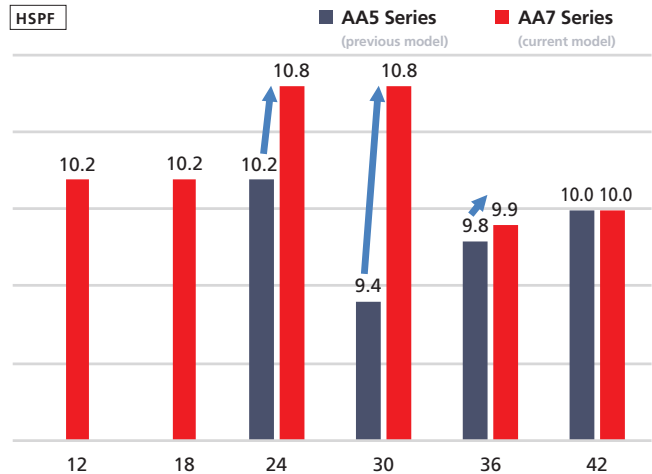
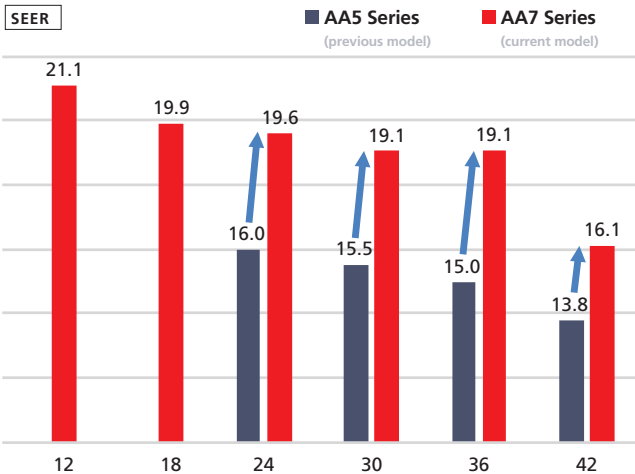

## Built-in Drain Lift Mechanism

All sizes feature a built-in drain lift mechanism for the removal of condensate. A fail-safe mechanism recognizes a high liquid level in the condensate pan and turns off the indoor fan and the outdoor unit compressor to prevent overflow.

# PEAD Model

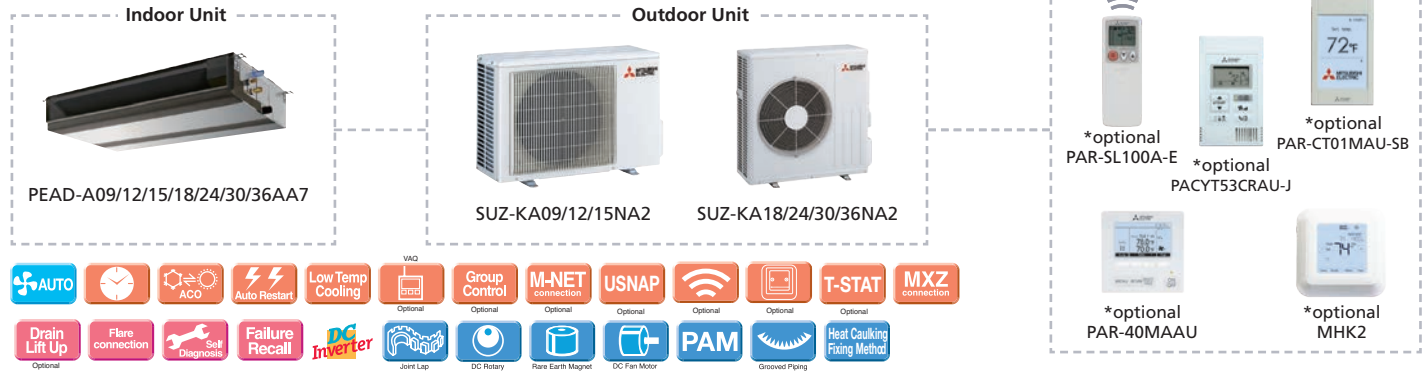

Indoor Unit				PEAD-A09AA7	PEAD-A12AA7	PEAD-A15AA7	PEAD-A18AA7	PEAD-A24AA7	PEAD-A30AA7	PEAD-A36AA7
Outdoor Unit				SUZ-KA09NA2	SUZ-KA12NA2	SUZ-KA15NA2	SUZ-KA18NA2	SUZ-KA24NA2	SUZ-KA30NA2	SUZ-KA36NA2
Cooling	Capacity	Rated <sup>1</sup>	BTU/H	9,000	12,000	15,000	18,000	24,000	27,000	33,000
	Capacity Range	Min-Max	BTU/H	4,300-9,000	4,400-12,000	5,500-15,000	6,200-18,000	12,000-24,000	13,200-27,000	14,000-33,000
	Power Input	Rated <sup>1</sup>	W	720	930	1,150	1,270	1,920	2,160	3,510
	Moisture Removal		Pints/h	0.8	1.1	1.3	3.2	4.9	3.9	4.8
	Sensible Heat Factor			0.900	0.900	0.900	0.800	0.770	0.840	0.840
Heating	Capacity at 47°F	Rated <sup>2</sup>	BTU/H	12,000	15,000	18,000	21,600	25,000	30,000	33,400
	Capacity Range	Min-Max	BTU/H	3,960-13,000	4,800-17,000	4,900-21,500	8,120-25,600	14,400-28,000	15,860-33,000	14,750-36,000
	Power Input at 47°F	Rated <sup>2</sup>	W	900	1,160	1,350	1,600	1,990	2,410	3,170
	Capacity at 17°F	Rated <sup>3</sup>	BTU/H	7,600	9,900	11,300	14,000	15,000	22,400	23,000
		Max	BTU/H	7,600	9,900	11,300	14,000	15,000	22,400	23,100
	Capacity at 5°F	Max <sup>4</sup>	BTU/H	6,100	7,900	10,100	12,000	—	—	—
	Capacity at -5°F	Max <sup>5</sup>	BTU/H	—	—	—	—	—	—	—
Efficiency	SEER			19.7	20.5	19.2	19.8	18.0	18.0	16.0
	EER			12.5	12.9	13.0	14.1	12.5	12.5	9.4
	HSPF			12.6	13.0	11.6	12.9	11.2	12.6	11.6
	COP			3.9	3.7	3.9	3.9	3.6	3.6	3.0
	ENERGY STAR® Certified			Yes	Yes	Yes	Yes	Yes	Yes	No
Indoor Unit	Air Flow Rate - Cooling (Quiet-Lo-Med-Hi-SHi)	Dry	CFM	282-318-353	353-424-494	424-512-600	424-512-600	512-635-741	618-742-883	847-1024-1201
	Air Flow Rate - Cooling (Quiet-Lo-Med-Hi-SHi)	Wet	CFM	254-286-318	318-382-445	382-461-540	382-461-540	461-572-667	556-668-795	762-922-1081
	Air Flow Rate - Heating (Quiet-Lo-Med-Hi-SHi)	Dry	CFM	282-318-353	353-424-494	424-512-600	424-512-600	512-635-741	618-742-883	847-1024-1201
	Sound Pressure Level (Quiet-Lo-Med-Hi-SHi)	Cooling	dB(A)	24-26-28	28-30-34	30-33-37	30-33-37	30-33-37	30-34-39	33-38-42
	Sound Pressure Level (Quiet-Lo-Med-Hi-SHi)	Heating	dB(A)	24-26-28	28-30-34	30-33-37	30-33-37	30-33-37	30-34-39	33-38-42
	External Static Pressure		In. W.G.	0.14-0.2-0.28-0.4-0.6	0.14-0.2-0.28-0.4-0.6	0.14-0.2-0.28-0.4-0.6	0.14-0.2-0.28-0.4-0.6	0.14-0.2-0.28-0.4-0.6	0.14-0.2-0.28-0.4-0.6	0.14-0.2-0.28-0.4-0.6
	Condensate Lift Mechanism	Max Distance	In. [mm]	279/16 [700]	27-9/16 [700]	279/16 [700]	27-9/16 [700]	27-9/16 [700]	27-9/16 [700]	27-9/16 [700]
	Dimensions	H	In. [mm]	9-7/8 [250]	9-7/8 [250]	9-7/8 [250]	9-7/8 [250]	9-7/8 [250]	9-7/8 [250]	9-7/8 [250]
		W	In. [mm]	35-7/16 [900]	35-7/16 [900]	35-7/16 [900]	35-7/16 [900]	43-5/16 [1100]	43-5/16 [1100]	55-1/8 [1400]
		D	In. [mm]	28-7/8 [732]	28-7/8 [732]	28-7/8 [732]	28-7/8 [732]	28-7/8 [732]	28-7/8 [732]	28-7/8 [732]
Weight		lbs [kg]		58 [26]	58 [26]	62 [28]	62 [28]	69 [31]	69 [31]	86 [39]
Outdoor Unit	MCA	A		9.0	9.0	10.0	14.0	17.0	17.0	17.0
	MOCP	A		15	16	18	24	31	31	31
	Dimensions	H	In. [mm]	21-5/8 [550]	21-5/8 [550]	21-5/8 [550]	34-5/8 [880]	34-5/8 [880]	34-5/8 [880]	34-5/8 [880]
		W	In. [mm]	31-1/2 [800]	31-1/2 [800]	31-1/2 [800]	33-1/16 [840]	33-1/16 [840]	33-1/16 [840]	33-1/16 [840]
		D	In. [mm]	11-1/4 [285]	11-1/4 [285]	11-1/4 [285]	13 [330]	13 [330]	13 [330]	13 [330]
	Weight	lbs [kg]		81 [37]	81 [37]	81 [37]	127 [58]	129 [59]	129 [59]	129 [59]
Air Flow Rate (Cooling/Heating)	CFM		1228/1172	1228/1172	1243/1229	1691/1691	2020/1930	2020/1930	2020/1930	
Piping	Diameter	Gas (O.D.)	In. [mm]	3/8 [9.52]	3/8 [9.52]	1/2 [12.7]	1/2 [12.7]	5/8 [15.88]	5/8 [15.88]	5/8 [15.88]
		Liquid (O.D)	In. [mm]	1/4 [6.35]	1/4 [6.35]	1/4 [6.35]	1/4 [6.35]	3/8 [9.52]	3/8 [9.52]	3/8 [9.52]
		Indoor Drain	In. [mm]	1-1/4 [32]	1-1/4 [32]	1-1/4 [32]	1-1/4 [32]	1-1/4 [32]	1-1/4 [32]	1-1/4 [32]
	Max. Length	ft [m]		65 [20]	65 [20]	65 [20]	100 [30]	100 [30]	100 [30]	100 [30]
Max. Height	ft [m]		40 [12]	40 [12]	40 [12]	50 [15]	100 [30]	100 [30]	100 [30]	
Electrical	Outdoor-Indoor <sup>6</sup>	V, ph, Hz		208/230, 1, 60	208/230, 1, 60	208/230, 1, 60	208/230, 1, 60	208/230, 1, 60	208/230, 1, 60	208/230, 1, 60
	Recommended Breaker Size	A		15	15	15	15	20	20	20
Refrigerant Type				R410A	R410A	R410A	R410A	R410A	R410A	R410A
Guaranteed Temperature Operation Range	Cooling <sup>7</sup>	°F DB [°C DB]		14 to 115 [-10.0 to 46.0]	14 to 115 [-10.0 to 46.0]	14 to 115 [-10.0 to 46.0]	14 to 115 [-10.0 to 46.0]	14 to 115 [-10.0 to 46.0]	14 to 115 [-10.0 to 46.0]	14 to 115 [-10.0 to 46.0]
	Heating	°F DB [°C DB]		-4 to -75 [-20.0 to 24.0]	-4 to -75 [-20.0 to 24.0]	-4 to -75 [-20.0 to 24.0]	-4 to -75 [-20.0 to 24.0]	-4 to -75 [-10.0 to 24.0]	-4 to -75 [-10.0 to 24.0]	-4 to -75 [-10.0 to 24.0]

Notes:  
 AHRI Rated Conditions (Rated data is determined at a fixed compressor speed)  
 Conditions  
<sup>1</sup>Cooling (Indoor // Outdoor) °F 80 DB, 67 WB // 95 DB, 75 WB  
<sup>2</sup>Heating at 47°F (Indoor // Outdoor) °F 70 DB, 60 WB // 47 DB, 43 WB  
<sup>3</sup>Heating at 17°F (Indoor // Outdoor) °F 70 DB, 60 WB // 17 DB, 15 WB  
<sup>4</sup>Heating at 5°F (Indoor // Outdoor) °F 70 DB, 60 WB // 5 DB, 4 WB  
<sup>5</sup>Heating at -5°F (Indoor // Outdoor) °F 70 DB, 60 WB // -5 DB, -6 WB  
<sup>6</sup>Indoor units receive power from outdoor units through field-supplied interconnected wiring.  
<sup>7</sup>Applications should be restricted to comfort cooling only; equipment cooling applications are not recommended for low ambient temperature conditions.

# PEAD Model

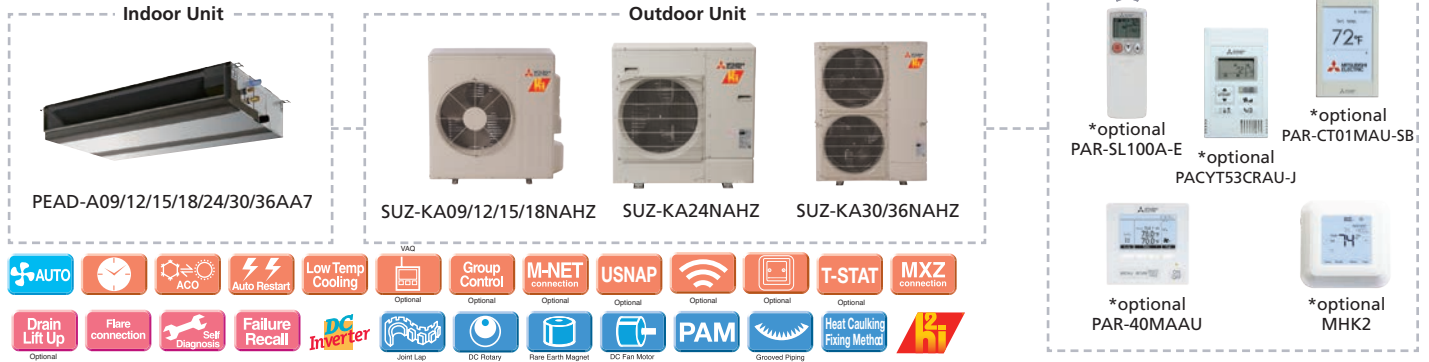

Indoor Unit				PEAD-A09AA7	PEAD-A12AA7	PEAD-A15AA7	PEAD-A18AA7	PEAD-A24AA7	PEAD-A30AA7	PEAD-A36AA7
Outdoor Unit				SUZ-KA09NAHZ	SUZ-KA12NAHZ	SUZ-KA15NAHZ	SUZ-KA18NAHZ	SUZ-KA24NAHZ	SUZ-KA30NAHZ	SUZ-KA36NAHZ
Cooling	Capacity	Rated <sup>1</sup>	BTU/H	9,000	12,000	15,000	18,000	24,000	30,000	33,000
	Capacity Range	Min-Max	BTU/H	5,000-9,000	5,770-12,000	9,600-15,000	9,320-18,000	10,000-24,000	14,600-30,000	15,600-33,000
	Power Input	Rated <sup>1</sup>	W	650	850	1,190	1,400	2,080	2,350	2,490
	Moisture Removal	Pints/h		1.4	1.9	2.4	3.6	6.9	6.5	3.6
	Sensible Heat Factor			0.820	0.820	0.820	0.780	0.680	0.760	0.880
Heating	Capacity at 47°F	Rated <sup>2</sup>	BTU/H	12,000	15,000	18,000	21,600	25,000	32,000	37,000
	Capacity Range	Min-Max	BTU/H	8,200-14,000	7,900-18,000	8,800-23,000	8,800-28,000	10,000-28,000	14,700-34,000	17,400-40,000
	Power Input at 47°F	Rated <sup>2</sup>	W	910	1,100	1,710	1,890	1,920	2,740	2,940
	Capacity at 17°F	Rated <sup>3</sup>	BTU/H	6,800	9,000	11,700	14,200	18,000	21,000	25,400
		Max	BTU/H	12,000	15,000	18,000	21,600	25,000	32,000	37,000
	Capacity at 5°F	Max <sup>4</sup>	BTU/H	12,000	15,000	18,000	21,600	25,000	32,000	37,000
Efficiency	Capacity at -5°F	Max <sup>5</sup>	BTU/H	—	—	—	—	—	—	—
	SEER			17.8	19.3	18.3	18.9	15.0	15.0	15.0
	EER			13.8	14.1	12.6	12.8	10.3	12.5	12.5
	HSPF			10.8	11.0	9.9	10.8	9.0	9.0	9.0
	COP			3.8	3.9	3.0	3.3	3.8	3.4	3.7
ENERGY STAR® Certified				Yes	Yes	Yes	Yes	No	Yes	Yes
Indoor Unit	Air Flow Rate - Cooling (Quiet-Lo-Med-Hi-SHi)	Dry	CFM	282-318-353	353-424-494	424-512-600	424-512-600	512-635-741	618-742-883	847-1024-1201
	Air Flow Rate - Cooling (Quiet-Lo-Med-Hi-SHi)	Wet	CFM	254-286-318	318-382-445	382-461-540	382-461-540	461-572-667	556-668-795	762-922-1081
	Air Flow Rate - Heating (Quiet-Lo-Med-Hi-SHi)	Dry	CFM	282-318-353	353-424-494	424-512-600	424-512-600	512-635-741	618-742-883	847-1024-1201
	Sound Pressure Level (Quiet-Lo-Med-Hi-SHi)	Cooling	dB(A)	24-26-28	28-30-34	30-33-37	30-33-37	30-33-37	30-34-39	33-38-42
	Sound Pressure Level (Quiet-Lo-Med-Hi-SHi)	Heating	dB(A)	24-26-28	28-30-34	30-33-37	30-33-37	30-33-37	30-34-39	33-38-42
	External Static Pressure	In. W.G.		0.14-0.2-0.28-0.4-0.6	0.14-0.2-0.28-0.4-0.6	0.14-0.2-0.28-0.4-0.6	0.14-0.2-0.28-0.4-0.6	0.14-0.2-0.28-0.4-0.6	0.14-0.2-0.28-0.4-0.6	0.14-0.2-0.28-0.4-0.6
	Condensate Lift Mechanism	Max Distance	In. [mm]	279/16 [700]	27-9/16 [700]	279/16 [700]	27-9/16 [700]	27-9/16 [700]	27-9/16 [700]	27-9/16 [700]
	Dimensions	H	In. [mm]	9-7/8 [250]	9-7/8 [250]	9-7/8 [250]	9-7/8 [250]	9-7/8 [250]	9-7/8 [250]	9-7/8 [250]
		W	In. [mm]	35-7/16 [900]	35-7/16 [900]	35-7/16 [900]	35-7/16 [900]	43-5/16 [1100]	43-5/16 [1100]	55-1/8 [1400]
		D	In. [mm]	28-7/8 [732]	28-7/8 [732]	28-7/8 [732]	28-7/8 [732]	28-7/8 [732]	28-7/8 [732]	28-7/8 [732]
Weight	lbs [kg]		58 [26]	58 [26]	62 [28]	62 [28]	69 [31]	69 [31]	86 [39]	
MCA	A		14.0	14.0	17.0	17.0	17.0	24.0	26.0	
MOC	A		24	24	31	31	27	40	42	
Outdoor Unit	Dimensions	H	In. [mm]	34-5/8 [880]	34-5/8 [880]	34-5/8 [880]	34-5/8 [880]	37-1/8 [943]	52-11/16 [1338]	52-11/16 [1338]
		W	In. [mm]	38-1/16 [840]	33-1/16 [840]	33-1/16 [840]	33-1/16 [840]	37-13/32 [950]	41-5/16 [1050]	41-5/16 [1050]
		D	In. [mm]	13 [330]	13 [330]	13 [330]	13 [330]	14-3/16 [360]	14-3/16 [360]	14-3/16 [360]
	Weight	lbs [kg]		129 [58.5]	129 [58.5]	131 [59.5]	131 [59.5]	190 [86]	261 [118]	261 [118]
Air Flow Rate (Cooling/Heating)	CFM		1,691/1,691	1,691/1,691	2,020/1,930	2,020/1,930	800/800	590/680	590/680	
Sound Pressure Level	Cooling	dB(A)	54	54	55	55	52	52	52	
	Heating	dB(A)	55	55	55	55	53	53	53	
Piping	Diameter	Gas (O.D.)	In. [mm]	3/8 [9.52]	3/8 [9.52]	1/2 [12.7]	1/2 [12.7]	5/8 [15.88]	5/8 [15.88]	5/8 [15.88]
		Liquid (O.D.)	In. [mm]	1/4 [6.35]	1/4 [6.35]	1/4 [6.35]	1/4 [6.35]	3/8 [9.52]	3/8 [9.52]	3/8 [9.52]
	Indoor Drain	In. [mm]	1-1/4 [32]	1-1/4 [32]	1-1/4 [32]	1-1/4 [32]	1-1/4 [32]	1-1/4 [32]	1-1/4 [32]	
Max. Length	ft [m]		65 [20]	65 [20]	65 [20]	100 [30]	165 [50]	245 [75]	245 [75]	
Max. Height	ft [m]		40 [12]	40 [12]	40 [12]	50 [15]	100 [30]	100 [30]	100 [30]	
Electrical	Outdoor-Indoor <sup>6</sup>	V, ph, Hz		208/230, 1, 60	208/230, 1, 60	208/230, 1, 60	208/230, 1, 60	208/230, 1, 60	208/230, 1, 60	208/230, 1, 60
	Recommended Breaker Size	A		15	15	20	20	25	35	35
Refrigerant Type				R410A	R410A	R410A	R410A	R410A	R410A	R410A
Guaranteed Temperature Operation Range	Cooling <sup>7</sup>	°F DB [°C DB]		0 to 115 [-10.0 to 46.0]	0 to 115 [-10.0 to 46.0]	0 to 115 [-10.0 to 46.0]	0 to 115 [-10.0 to 46.0]	0 to 115 [-10.0 to 46.0]	0 to 115 [-10.0 to 46.0]	0 to 115 [-10.0 to 46.0]
	Heating	°F DB [°C DB]		-13 to 75 [-25.0 to 24.0]	-13 to 75 [-25.0 to 24.0]	-13 to 75 [-25.0 to 24.0]	-13 to 75 [-25.0 to 24.0]	-13 to 75 [-25.0 to 24.0]	-13 to 75 [-25.0 to 24.0]	-13 to 75 [-25.0 to 24.0]

Notes:  
 AHRI Rated Conditions (Rated data is determined at a fixed compressor speed)  
<sup>1</sup>Cooling (Indoor // Outdoor) °F 80 DB, 67 WB // 95 DB, 75 WB  
<sup>2</sup>Heating at 47°F (Indoor // Outdoor) °F 70 DB, 60 WB // 47 DB, 43 WB  
<sup>3</sup>Heating at 17°F (Indoor // Outdoor) °F 70 DB, 60 WB // 17 DB, 15 WB  
<sup>4</sup>Heating at 5°F (Indoor // Outdoor) °F 70 DB, 60 WB // 5 DB, 4 WB  
<sup>5</sup>Heating at -5°F (Indoor // Outdoor) °F 70 DB, 60 WB // -5 DB, -6 WB  
 Conditions  
<sup>6</sup>Indoor units receive power from outdoor units through field-supplied interconnected wiring.  
<sup>7</sup>Applications should be restricted to comfort cooling only; equipment cooling applications are not recommended for low ambient temperature conditions.





Next steps to  
longer walk  
with Jesus  
philizing and modeling

**P-Series**

Our professional line of products provide solutions for residential and commercial single-zone applications.



# P-Series Product Lineup

The P-Series lineup includes a selection of six indoor units and three categories of outdoor units. You can easily build a system that best matches the application's heating and cooling needs.

## Step 1: Select your Indoor Unit



4-Way Ceiling Cassette PLA



Wall-mounted PKA-HA



Wall-mounted PKA-KA



Multi-position Air Handler PVA



Ceiling-concealed PEAD



Ceiling-suspended PCA

## Step 2: Select your Outdoor Unit

Choose from Cooling Only, Heat Pump, or Hyper-heating models.

### Cooling Only



PUY-A12NKA7



PUY-A18NKA7



PUY-A24NHA7



PUY-A30NHA7



PUY-A36NKA7



PUY-A42NKA7

### Heat Pump



PUZ-A12NKA7



PUZ-A18NKA7



PUZ-A24NHA7



PUZ-A30NHA7



PUZ-A36NKA7



PUZ-A42NKA7

### Hyper-Heating INVERTER® Heat Pump



PUZ-HA24NHA1



PUZ-HA30NKA



PUZ-HA36NKA



PUZ-HA42NKA1

# P-Series

Industry-leading energy efficiency has been achieved by optimizing a newly designed compressor and using the latest energy-saving technologies. All compressors offer high performance due to advanced variable-speed INVERTER-drive technology, which varies the compressor speed dynamically to adapt to the room's conditioning requirements.

## Industry Leading Energy Efficiency

Industry-leading energy efficiency has been achieved through optimization of a newly designed compressor and the use of the latest energy-saving technologies. All compressors offer high performance due to advanced variable-speed INVERTER-drive technology, which varies the compressor speed dynamically to continuously adapt to the conditioning requirements of the room.

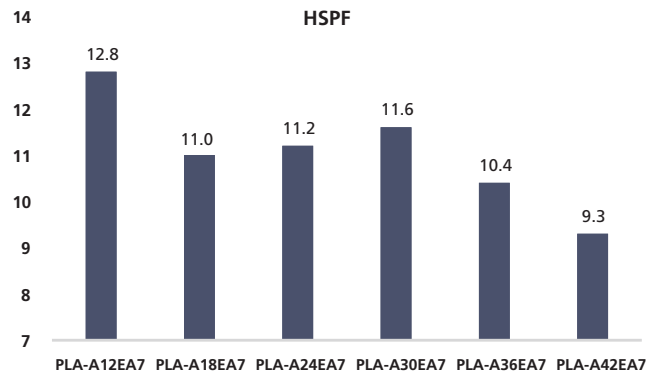
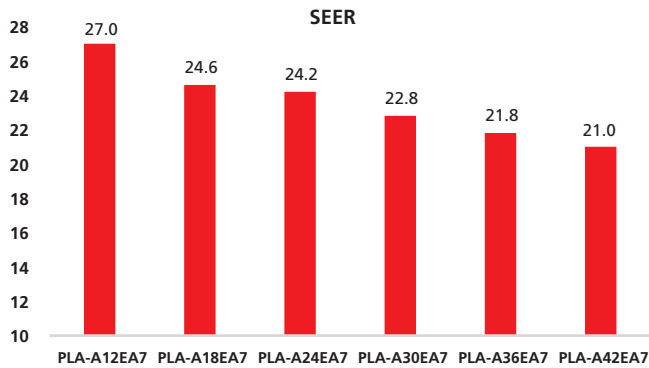

## Advanced Energy-Saving Technology

### Highly efficient fan for outdoor unit

#### Fan opening of 21-3/4" (A36-42)

The opening for the fan in the outdoor unit is 21-3/4" in diameter. Exchanging heat more efficiently contributes to increased energy-savings and lower noise levels.



### Improved fan (A36-42)

A newly designed fan increases airflow capacity and reduces operation noise.

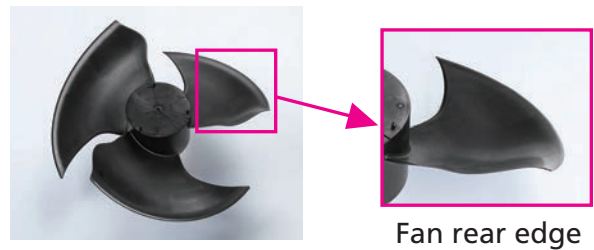

### Highly efficient heat exchanger

#### High-density heat exchanger (A36-42)

The A36-42 units use a 5/16" diameter pipe. The high-density heat exchanger contributes to efficient heat exchange and reduces the amount of refrigerant used, which benefits the environment.

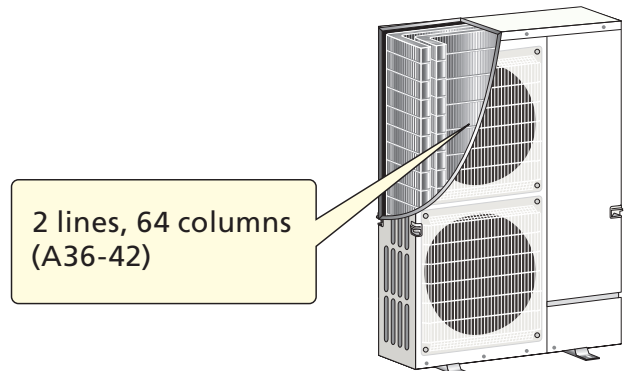



# Cooling Only

## PUY Model

### High Reliability and Performance in Low Ambient Conditions

The PUY Model cooling only unit provides cooling all year round, even in cold climate low ambient conditions. By controlling the fan speed, the PUY can offer stable cooling operation down to -40° F.

\*Optional Air Protection Guide/Wind Baffle is needed when ambient temperature is under 23° F.

#### Low Ambient Cooling Operation Range

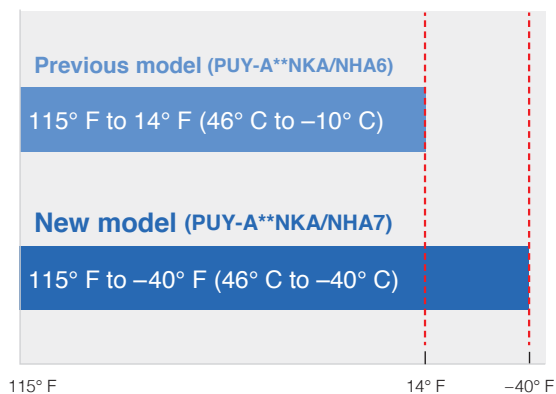

#### Piping Length

	Piping	
	Length (ft)	Height (ft)
PUZ-A12NKA7	100	100
PUZ-A18NKA7	100	100
PUZ-A24NHA7	165	100
PUZ-A30NHA7	165	100
PUZ-A36NKA7	165	100
PUZ-A42NKA7	165	100

#### Quick Auto Restart After Power Failure

In case of power failures, auto restart time shortens from 180 seconds to 60 seconds. The unit starts back up in the same operation mode it ran when the power failure occurred.

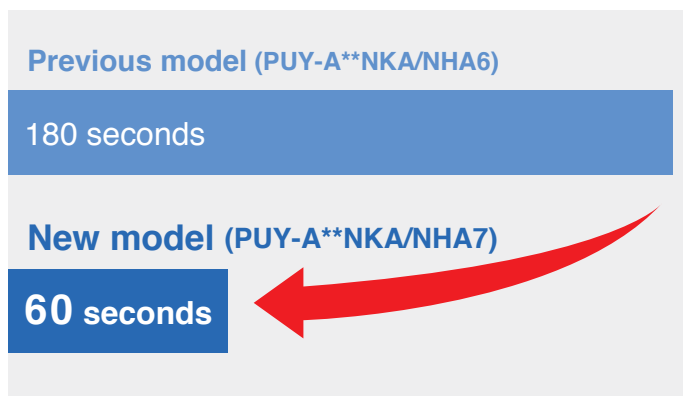

#### Backup Rotation Function

The two units operate alternately to maintain equal runtimes and equivalent wear, extending their life. In this configuration, if one unit experiences issues, the other unit continues to operate.

\*Can only be used with PAR-40MAAU controller

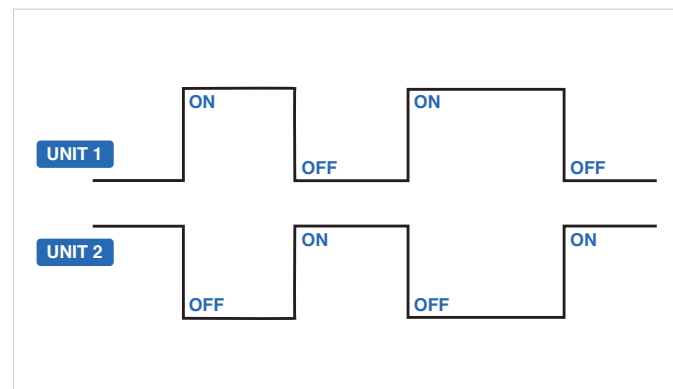

#### Continuous Operation

A control algorithm allows for stable continuous operation to meet cooling requirements all year round. The unit will quickly restart with the same operation mode as before the power failure.



# Heat Pump

**PUZ Model**  
**Quiet Operation**  
**Sound Level**

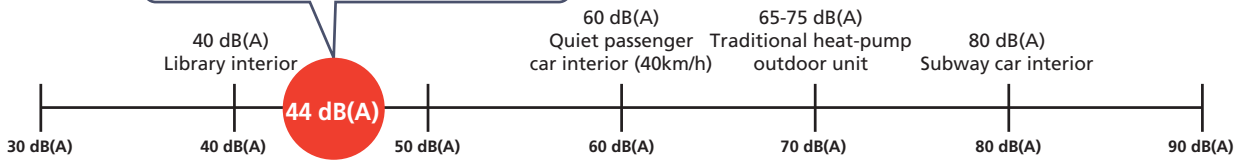

## Wide Operation Range

P-Series heat pumps offer a wide temperature operation range, easily fitting many climate design conditions.

**Cooling** 0° F\*1 to 115° F (46° C to -18.8° C)

**Heating** -4° F to 70° F (-20° C to 19° C)\*2

\*1 In case that the air protection guide wind baffle is installed. (In case the wind baffle is not installed, the minimum temperature will be 23° F (-5° C) DB)  
 \*2 A24/30/36/42

## Flexible Installation

### Long Piping Length

Long piping lengths enable system design flexibility for applications such as apartment buildings, churches, or strip malls.

	Piping	
	Length (ft)	Height (ft)
PUZ-A12NKA7	100	100
PUZ-A18NKA7	100	100
PUZ-A24NHA7	165	100
PUZ-A30NHA7	165	100
PUZ-A36NKA7	165	100
PUZ-A42NKA7	165	100

## Energy Efficiency

■ HSPF ■ SEER

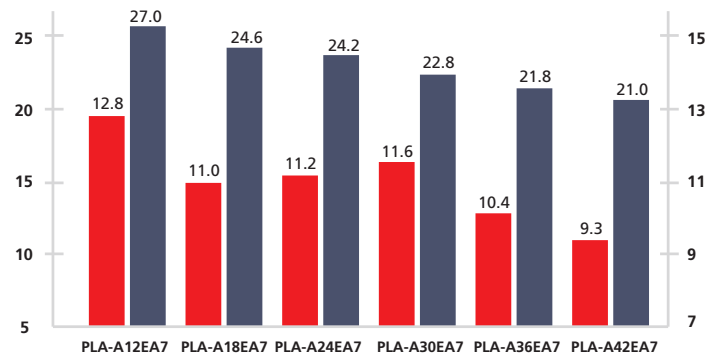

# Hyper-Heating INVERTER®

## PUZ-HA Model

### Improved Heating Performance

Our unique Flash Injection circuit achieves remarkably high heating performance. This technology has resulted in excellent heating capacity ratings in outdoor temperatures as low as 5° F. The guaranteed heating operation range of the heating mode extends to -13° F.

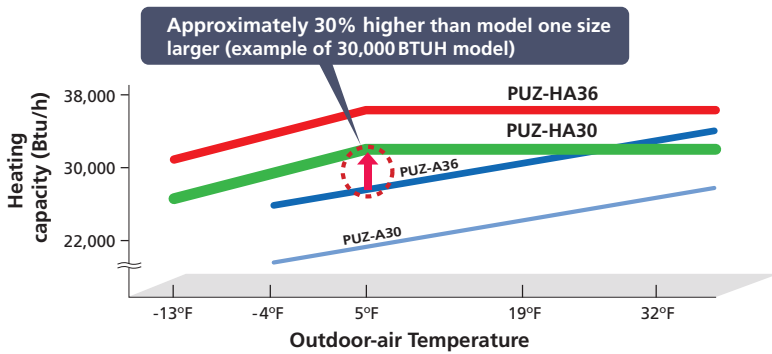

Guaranteed heating operation range is extended to -13° F ambient temperature

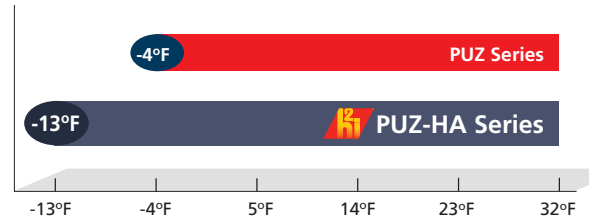

## Enhanced Comfort

The Flash Injection circuit improves start-up and recovery from the defrosting operation. The defrost operation control improves the required defrost frequency. These features enable the temperature to reach the set point fast and contribute to maintaining the desired setting.

### Quick Start-up

Operation at 36° F outdoor temperature

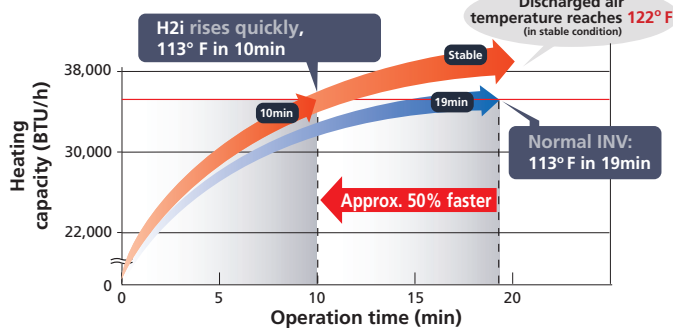

Operation at -4° F outdoor temperature

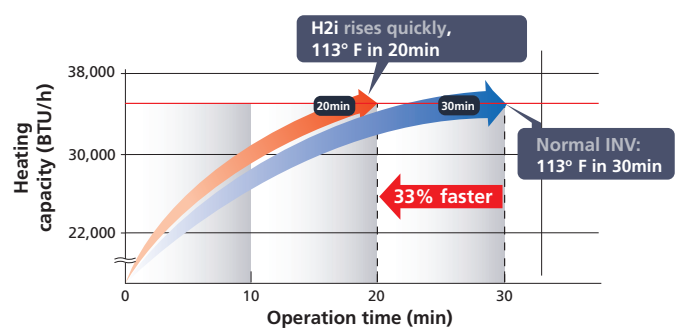

### H2i Defrost Control and Faster Recovery from Defrost Operation

Field Test Results: Office building in Asahikawa, Hokkaido, Japan

Operation data for 25 Jan. 2005

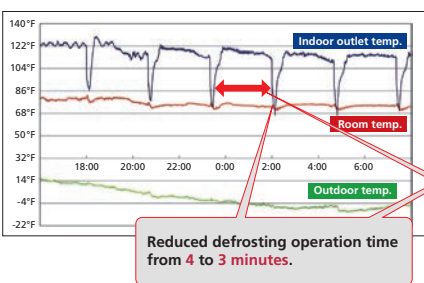

Operation data for 2 Dec. 2004

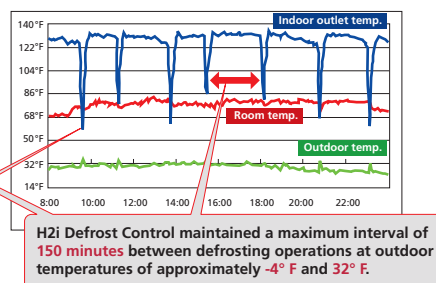

Installation example

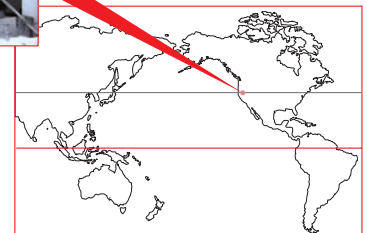



# PLA Model

Four-way Ceiling Cassette



## Four-way Ceiling Cassette Lineup

The PLA Model offers an extensive lineup with capacities ranging from 12 to 42 KBTU/H.

Line-up

Series	Model	12	18	24	30	36	42
4-way Cassette (PLA-A)		PLA-A12EA7	PLA-A18EA7	PLA-A24EA7	PLA-A30EA7	PLA-A36EA7	PLA-A42EA7

Key Technologies for Higher Energy Efficiency

**3D Turbo Fan**

By optimizing the fan blade wing design using a three-dimensional shape, efficiency has been improved and operating noise reduced.

Indoor/Outdoor Unit Combinations



Four-way Cassette PLA-A EA

Power Inverter



PUY/PUZ-A12/18



PUY/PUZ-A24/30



PUY/PUZ-A36/42



PUY-HA24



PUZ-HA30/36/42

## Improved Energy-Saving Performance

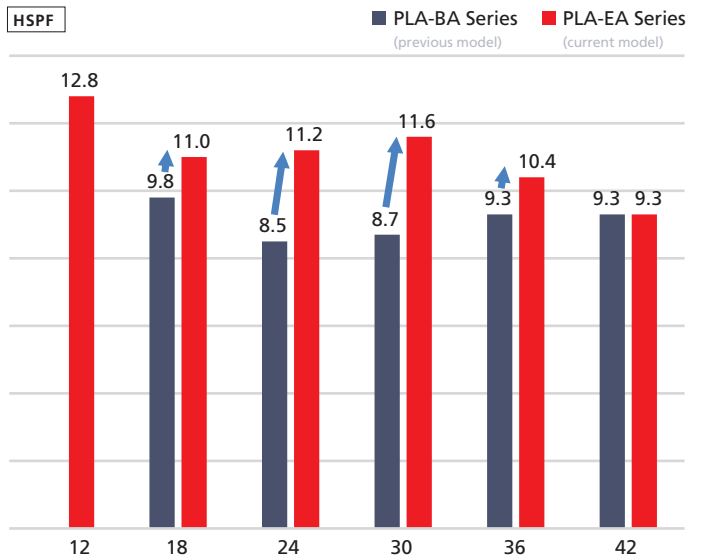
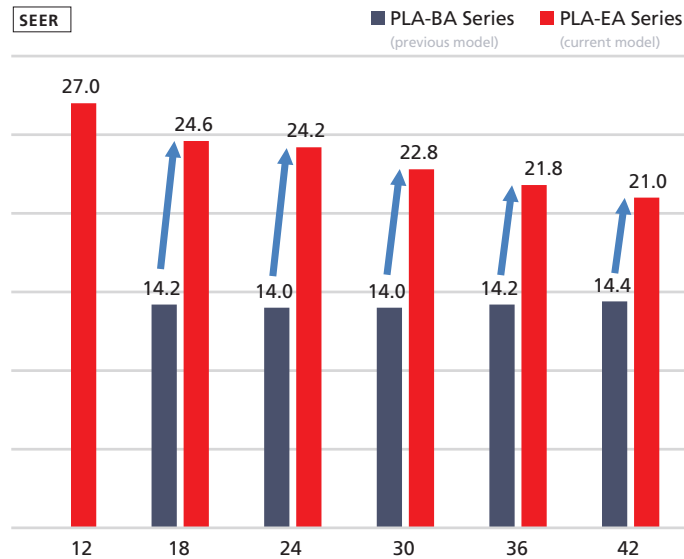

## Horizontal Airflow

### Draft Reduction Vane Setting

The Draft Reduction vane setting adjusts airflow direction more horizontal than the standard vane setting reducing drafts dramatically.

\*The draft reduction can be set for only 1 vane. PAR-40MAAU is required for this setting.

### Individual Vane Settings

An astonishing 72 unique airflow patterns are available to accommodate different room layouts. Select any combination of 2, 3, or 4 vanes to deliver air into the area. Further, personalize comfort by adjusting the vane up or down to set air direction.

## Easy Installation

### Electrical Box Wiring

Product design improvements to the power supply terminal position enhance connectivity and increase ease of installation.

Previous Model (BA Model)

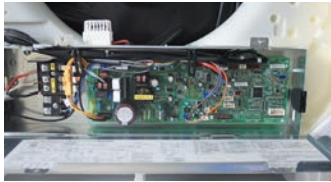

New Model (EA Model)



### Temporary Hanging Hook

The updated product design includes temporary hanging hooks, improving work efficiency during installation.

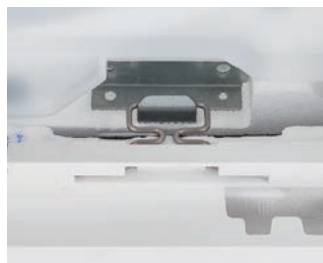
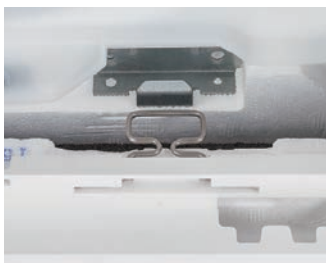

### Lightweight Decorative Panel

The updated product grille is 20% lighter weight compared to the previous model.

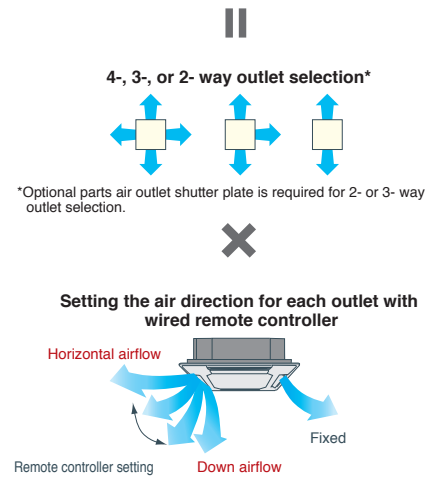

### Increased Space For Piping Work

The updated product design includes reversing the gas and liquid line connections to enhance piping installation. Additional piping improvements include increased space surrounding the connections, permitting a larger wrench turning radius.

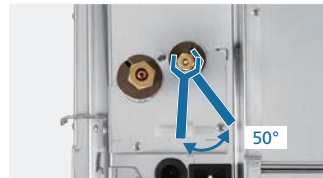

### No Need To Remove Screws

Captive screws added to the corner panel and control box make working overhead much easier.

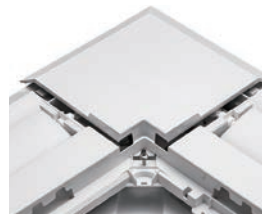

Corner Panel



Corner Box Cover

# 3D i-see Sensor for P-Series

## Detects Number Of People

The 3D i-see Sensor® detects the number of people in the room and adjusts the power accordingly. This makes automatic power-saving operation possible in places where the number of people changes frequently. Additionally, when the area is continuously unoccupied, the system switches to a more enhanced power-saving mode. Depending on the setting, it can also stop the operation.

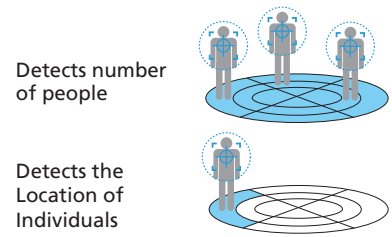
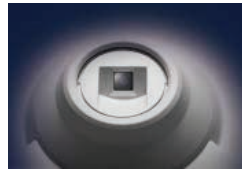

## Detects People's Position

Once a person is detected, the angle of the vane is automatically adjusted. Each vane can be independently set to Direct Airflow or Indirect Airflow according to taste.

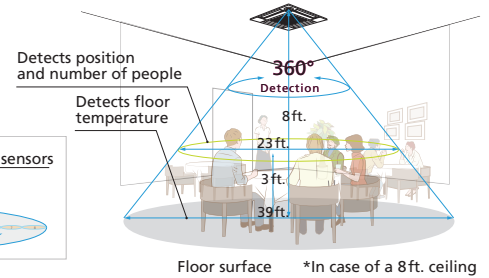
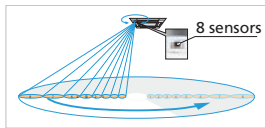

## Room Occupancy Energy-Saving Mode

The 3D i-see Sensor detects the number of people in the room. It then calculates the occupancy rate based on the maximum number of people in the room up to that point in time in order to save air conditioning power. When the occupancy rate is approximately 30%, air-conditioning power equivalent to 2° F during both cooling and heating operation is saved. The temperature is controlled according to the number of people.

Room Occupancy Energy Save Mode



No Occupancy Energy Save Mode



No Occupancy Auto Off Mode

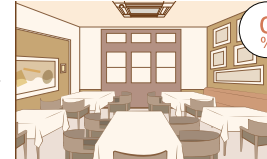

\*PAR-40MAAU is required for each setting

## No Occupancy Energy-Saving Mode

When 3D i-see Sensor detects that no one is the room, the system is switched to a preset power-saving mode. If the room remains unoccupied for more than 60min, air-conditioning power equivalent to 4° F during both cooling and heating operation is saved. This contributes to preventing waste in terms of heating and cooling.

## No Occupancy Auto-Off Mode

When the room remains unoccupied for a preset period of time, the air conditioner turns off automatically, thereby providing even greater power savings. The time until operation is stopped can be set in intervals of 10 min, ranging from 60 to 180 min.

## Seasonal Airflow\*

### When Cooling

Saves energy while keeping a comfortable effective temperature by automatically switching between ventilation and cooling. When a preset temperature is reached, the air conditioning unit switches to swing fan operation to maintain the effective temperature. This clever function contributes to keeping a comfortable coolness.

### When Heating

The air conditioning unit automatically switches between circulator and heating. Wasted heat that accumulates near the ceiling is reused via circulation. When a preset temperature is reached the air conditioner switches from heating to circulator and blows air in the horizontal direction. It pushes down the warm air that has gathered near the ceiling to people's height, thereby providing smart heating.

## Direct/Indirect Settings\*

The horizontal airflow spreads across the ceiling. When set to Indirect Airflow uncomfortable drafty-feeling is eliminated completely.



# PLA Model



## Model Selection

### Indoor Unit



PLA-A12/18/24/30/36/42EA7



Required grille: PLP-41EAEU

### Outdoor Unit

#### Cooling Only



PUY-A12/18NKA7



PUY-A24/30NHA7



PUY-A36/42NKA7

#### Heat Pump



PUZ-A12/18NKA7



PUZ-A24/30NHA7



PUZ-A36/42NKA7

#### Hyper-heating



PUZ-HA24NH1



PUZ-HA30/36NKA



PUZ-HA42NK1

### Remote Controller



\*optional  
PAR-40MAAU



\*optional  
PAC-YT53CRAU-J



\*optional



\*optional  
PAR-CT01MAU-SB



\*optional  
MHK2

# PLA Model



## Cooling Only

Indoor Unit				PLA-A12EA7	PLA-A18EA7	PLA-A24EA7	PLA-A30EA7	PLA-A36EA7	PLA-A42EA7
Outdoor Unit				PUY-A12NKA7(-BS)	PUY-A18NKA7(-BS)	PUY-A24NHA7(-BS)	PUY-A30NHA7(-BS)	PUY-A36NKA7(-BS)	PUY-A42NKA7(-BS)
Cooling	Capacity	Rated <sup>1</sup>	BTU/H	12,000	18,000	24,000	30,000	36,000	42,000
	Capacity Range	Min-Max	BTU/H	5,800–12,000	8,000–18,000	10,000–24,000	9,000–30,000	16,000–36,000	16,000–42,000
	Power Input	Rated <sup>1</sup>	W	730	1,250	1,670	2,540	2,780	3,590
	Moisture Removal	Pints/h		1.2	2.4	3.0	5.4	4.5	7.9
	Sensible Heat Factor			0.890	0.850	0.860	0.800	0.860	0.790
Heating	Capacity at 47°F	Rated	BTU/H	—	—	—	—	—	—
	Capacity Range	Min-Max	BTU/H	—	—	—	—	—	—
	Power Input at 47°F	Rated	W	—	—	—	—	—	—
	Capacity at 17°F	Rated	BTU/H	—	—	—	—	—	—
		Max	BTU/H	—	—	—	—	—	—
	Capacity at 5°F	Max	BTU/H	—	—	—	—	—	—
Efficiency	SEER			27.0	24.6	24.2	22.8	21.8	21.0
	EER			16.4	14.4	14.3	11.8	12.9	11.6
	HSPF			—	—	—	—	—	—
	COP			—	—	—	—	—	—
	ENERGY STAR® Certified			Yes	Yes	Yes	No	Yes	No
Indoor Unit	Air Flow Rate - Cooling (Quiet-Lo-Med-Hi-SHi)	Dry	CFM	420-460-490-530	420-460-570-600	530-640-710-810	570-670-780-880	670-850-1020-1200	740-920-1060-1200
	Air Flow Rate - Cooling (Quiet-Lo-Med-Hi-SHi)	Wet	CFM	380-420-450-490	380-420-530-560	490-600-670-770	530-630-740-840	630-810-980-1160	700-880-1020-1160
	Air Flow Rate - Heating (Quiet-Lo-Med-Hi-SHi)	Dry	CFM	420-460-490-530	420-460-570-600	530-640-710-810	570-670-780-880	670-850-1020-1200	740-920-1060-1200
	Sound Pressure Level (Quiet-Lo-Med-Hi-SHi)	Cooling	dB(A)	27-28-29-30	28-29-31-32	28-30-33-36	28-32-35-38	32-37-41-44	34-38-42-45
	Sound Pressure Level (Quiet-Lo-Med-Hi-SHi)	Heating	dB(A)	27-28-29-30	28-29-31-32	28-30-33-36	28-32-35-38	32-37-41-44	34-38-42-45
	External Static Pressure		In. W.G.	—	—	—	—	—	—
	Condensate Lift Mechanism	Max Distance	In. [mm]	33-7/16 [849]	33-7/16 [849]	33-7/16 [849]	33-7/16 [849]	33-7/16 [849]	33-7/16 [849]
	Dimensions	H	In. [mm]	10-5/32 // 1-9/16 [258 // 40]	10-5/32 // 1-9/16 [258 // 40]	11-3/4 // 1-9/16 [298 // 40]	11-3/4 // 1-9/16 [298 // 40]	11-3/4 // 1-9/16 [298 // 40]	11-3/4 // 1-9/16 [298 // 40]
		W	In. [mm]	33-1/16 // 37-13/32 [840 // 950]	33-1/16 // 37-13/32 [840 // 950]	33-1/16 // 37-13/32 [840 // 950]	33-1/16 // 37-13/32 [840 // 950]	33-1/16 // 37-13/32 [840 // 950]	33-1/16 // 37-13/32 [840 // 950]
		D	In. [mm]	33-1/16 // 37-13/32 [840 // 950]	33-1/16 // 37-13/32 [840 // 950]	33-1/16 // 37-13/32 [840 // 950]	33-1/16 // 37-13/32 [840 // 950]	33-1/16 // 37-13/32 [840 // 950]	33-1/16 // 37-13/32 [840 // 950]
		Weight	lbs [kg]		46 // 11 [21 // 5]	46 // 11 [21 // 5]	56 // 11 [25 // 5]	56 // 11 [25 // 5]	56 // 11 [25 // 5]
Outdoor Unit	MCA	A		11.0	11.0	19.0	19.0	25.0	25.0
	MOC	A		28	28	26	26	31	31
	Dimensions	H	In. [mm]	24-13/16 [630]	24-13/16 [630]	37-1/8 [943]	37-1/8 [943]	52-11/16 [1338]	52-11/16 [1338]
		W	In. [mm]	31-13/16 (+7/16) [809 (+62)]	31-13/16 (+7/16) [809 (+62)]	37-13/32 [950]	37-13/32 [950]	41-5/16 [1050]	41-5/16 [1050]
		D	In. [mm]	11-3/16 [300]	11-3/16 [300]	13 (+1-3/16) [330 (+30)]	13 (+1-3/16) [330 (+30)]	13 (+1-3/16) [330 (+30)]	13 (+1-3/16) [330 (+30)]
	Weight	lbs [kg]		92 [41]	99 [44]	151 [68]	151 [68]	211 [96]	211 [96]
	Air Flow Rate (Cooling/Heating)	CFM		1590/—	1590/—	1940/—	1940/—	3880/—	3880/—
	Sound Pressure Level	Cooling	dB(A)	44	44	47	47	52	52
Heating		dB(A)	—	—	—	—	—	—	
Piping	Diameter	Gas (O.D.)	In. [mm]	1/2 [12.7]	1/2 [12.7]	5/8 [15.88]	5/8 [15.88]	5/8 [15.88]	5/8 [15.88]
		Liquid (O.D)	In. [mm]	1/4 [6.35]	1/4 [6.35]	3/8 [9.52]	3/8 [9.52]	3/8 [9.52]	3/8 [9.52]
		Indoor Drain	In. [mm]	1-1/4 [32]	1-1/4 [32]	1-1/4 [32]	1-1/4 [32]	1-1/4 [32]	1-1/4 [32]
	Max. Length	ft [m]		165 [50]	165 [50]	225 [68]	225 [68]	225 [68]	225 [68]
Max. Height	ft [m]		100 [30]	100 [30]	100 [30]	100 [30]	100 [30]	100 [30]	
Electrical	Outdoor-Indoor <sup>5</sup>	V, ph, Hz		208/230, 1, 60	208/230, 1, 60	208/230, 1, 60	208/230, 1, 60	208/230, 1, 60	208/230, 1, 60
	Recommended Breaker Size	A		15	15	25	25	30	30
Refrigerant Type				R410A	R410A	R410A	R410A	R410A	R410A
Guaranteed Temperature Operation Range	Cooling <sup>6</sup>	°F DB [°C DB]		-40 to 115 [-40 to 46]	-40 to 115 [-40 to 46]	-40 to 115 [-40 to 46]	-40 to 115 [-40 to 46]	-40 to 115 [-40 to 46]	-40 to 115 [-40 to 46]
	Heating	°F DB [°C DB]		—	—	—	—	—	—

Notes:  
<sup>1</sup>AHRI Rated Conditions  
<sup>2</sup>Cooling (Indoor // Outdoor)      °F      80 DB, 67 WB // 95 DB, 75 WB  
 (Rated data is determined at a fixed compressor speed)

<sup>3</sup>Indoor units receive power from outdoor units through field-supplied interconnected wiring.  
<sup>4</sup>Wind baffles required to operate below 23°F DB in cooling mode. PUY with wind baffle: -40°F - 115°F. Refer to wind baffle documentation for further information.  
 SEACOAST PROTECTION

- External Outer Panel: Phosphate coating + Acrylic-Enamel coating
- Fan Motor Support: Epoxy resin coating (at edge face)
- Separator Assembly, Valve Bed: Epoxy resin coating (at edge face)
- "Blue Fin" treatment is an anti-corrosion treatment that is applied to the condenser coil to protect it against airborne contaminants.

# PLA Model

## Heat Pump



Indoor Unit				PLA-A12EA7	PLA-A18EA7	PLA-A24EA7	PLA-A30EA7	PLA-A36EA7	PLA-A42EA7
Outdoor Unit				PUZ-A12NKA7(-BS)	PUZ-A18NKA7(-BS)	PUZ-A24NHA7(-BS)	PUZ-A30NHA7(-BS)	PUZ-A36NKA7(-BS)	PUZ-A42NKA7(-BS)
Cooling	Capacity	Rated <sup>1</sup>	BTU/H	12,000	18,000	24,000	30,000	36,000	42,000
	Capacity Range	Min-Max	BTU/H	5,800–12,000	8,000–18,000	10,000–24,000	9,000–30,000	16,000–36,000	16,000–42,000
	Power Input	Rated <sup>1</sup>	W	730	1,250	1,670	2,540	2,780	3,590
	Moisture Removal	Pints/h		1.2	2.4	3.0	5.4	4.5	7.9
	Sensible Heat Factor			0.890	0.850	0.860	0.800	0.860	0.790
Heating	Capacity at 47°F	Rated <sup>2</sup>	BTU/H	14,000	19,000	26,000	32,000	38,000	45,000
	Capacity Range	Min-Max	BTU/H	5,500–20,000	7,900–23,000	9,000–29,000	9,000–33,000	18,000–42,000	18,000–48,000
	Power Input at 47°F	Rated <sup>2</sup>	W	830	1,300	1,750	2,400	2,540	3,290
	Capacity at 17°F	Rated <sup>3</sup>	BTU/H	10,100	11,000	14,900	18,100	22,000	28,000
	Capacity at 5°F	Max <sup>4</sup>	BTU/H	13,000	12,000	13,000	16,800	21,600	26,900
	Capacity at -5°F	Max	BTU/H	—	—	—	—	—	—
Efficiency	SEER			27.0	24.6	24.2	22.8	21.8	21.0
	EER			16.4	14.4	14.3	11.8	12.9	11.6
	HSPF			12.8	11.0	11.2	11.6	10.4	9.3
	COP			4.94	4.28	4.35	3.9	4.38	4.0
	ENERGY STAR® Certified			Yes	Yes	Yes	No	Yes	No
Indoor Unit	Air Flow Rate - Cooling (Quiet-Lo-Med-Hi-SHi)	Dry	CFM	420–460–490–530	420–460–570–600	530–640–710–810	570–670–780–880	670–850–1020–1200	740–920–1060–1200
	Air Flow Rate - Cooling (Quiet-Lo-Med-Hi-SHi)	Wet	CFM	380–420–450–490	380–420–530–560	490–600–670–770	530–630–740–840	630–810–980–1160	700–880–1020–1160
	Air Flow Rate - Heating (Quiet-Lo-Med-Hi-SHi)	Dry	CFM	420–460–490–530	420–460–570–600	530–640–710–810	570–670–780–880	670–850–1020–1200	740–920–1060–1200
	Sound Pressure Level (Quiet-Lo-Med-Hi-SHi)	Cooling	dB(A)	27–28–29–30	28–29–31–32	28–30–33–36	28–32–35–38	32–37–41–44	34–38–42–45
	Sound Pressure Level (Quiet-Lo-Med-Hi-SHi)	Heating	dB(A)	27–28–29–30	28–29–31–32	28–30–33–36	28–32–35–38	32–37–41–44	34–38–42–45
	External Static Pressure		In. W.G.	—	—	—	—	—	—
	Condensate Lift Mechanism	Max Distance	In. [mm]	33-7/16 [849]	33-7/16 [849]	33-7/16 [849]	33-7/16 [849]	33-7/16 [849]	33-7/16 [849]
	Dimensions	H	In. [mm]	10-5/32 // 1-9/16 [258 // 40]	10-5/32 // 1-9/16 [258 // 40]	11-3/4 // 1-9/16 [298 // 40]	11-3/4 // 1-9/16 [298 // 40]	11-3/4 // 1-9/16 [298 // 40]	11-3/4 // 1-9/16 [298 // 40]
		W	In. [mm]	33-1/16 // 37-13/32 [840 // 950]	33-1/16 // 37-13/32 [840 // 950]	33-1/16 // 37-13/32 [840 // 950]	33-1/16 // 37-13/32 [840 // 950]	33-1/16 // 37-13/32 [840 // 950]	33-1/16 // 37-13/32 [840 // 950]
		D	In. [mm]	33-1/16 // 37-13/32 [840 // 950]	33-1/16 // 37-13/32 [840 // 950]	33-1/16 // 37-13/32 [840 // 950]	33-1/16 // 37-13/32 [840 // 950]	33-1/16 // 37-13/32 [840 // 950]	33-1/16 // 37-13/32 [840 // 950]
		Weight	lbs [kg]		46 // 11 [21 // 5]	46 // 11 [21 // 5]	56 // 11 [25 // 5]	56 // 11 [25 // 5]	56 // 11 [25 // 5]
Outdoor Unit	MCA	A		11.0	11.0	19.0	19.0	25.0	25.0
	MOCP	A		28	28	26	26	31	31
	Dimensions	H	In. [mm]	24-13/16 [630]	24-13/16 [630]	37-1/8 [943]	37-1/8 [943]	52-11/16 [1338]	52-11/16 [1338]
		W	In. [mm]	31-13/16 (+7/16) [809 (+62)]	31-13/16 (+7/16) [809 (+62)]	37-13/32 [950]	37-13/32 [950]	41-5/16 [1050]	41-5/16 [1050]
		D	In. [mm]	11-3/16 [300]	11-3/16 [300]	13 (+1-3/16) [330 (+30)]	13 (+1-3/16) [330 (+30)]	13 (+1-3/16) [330 (+30)]	13 (+1-3/16) [330 (+30)]
	Weight	lbs [kg]		93 [42]	100 [45]	153 [69]	153 [69]	214 [97]	214 [97]
	Air Flow Rate (Cooling/Heating)	CFM		1590/1590	1590/1590	1940/1940	1940/1940	3880/3880	3880/3880
	Sound Pressure Level	Cooling	dB(A)	44	44	47	47	52	52
Heating		dB(A)	46	46	48	48	53	53	
Piping	Diameter	Gas (O.D.)	In. [mm]	1/2 [12.7]	1/2 [12.7]	5/8 [15.88]	5/8 [15.88]	5/8 [15.88]	5/8 [15.88]
		Liquid (O.D)	In. [mm]	1/4 [6.35]	1/4 [6.35]	3/8 [9.52]	3/8 [9.52]	3/8 [9.52]	3/8 [9.52]
		Indoor Drain	In. [mm]	1-1/4 [32]	1-1/4 [32]	1-1/4 [32]	1-1/4 [32]	1-1/4 [32]	1-1/4 [32]
	Max. Length	ft [m]		100 [30]	100 [30]	165 [50]	165 [50]	165 [50]	165 [50]
Max. Height	ft [m]		100 [30]	100 [30]	100 [30]	100 [30]	100 [30]	100 [30]	
Electrical	Outdoor-Indoor <sup>5</sup>	V, ph, Hz		208/230, 1, 60	208/230, 1, 60	208/230, 1, 60	208/230, 1, 60	208/230, 1, 60	208/230, 1, 60
	Recommended Breaker Size	A		15	15	25	25	30	30
Refrigerant Type				R410A	R410A	R410A	R410A	R410A	R410A
Guaranteed Temperature Operation Range	Cooling <sup>6</sup>	°F DB [°C DB]		0 to 115 [-18 to 46]	0 to 115 [-18 to 46]	0 to 115 [-18 to 46]	0 to 115 [-18 to 46]	0 to 115 [-18 to 46]	0 to 115 [-18 to 46]
	Heating	°F DB [°C DB]		12 to 70 [-11 to 21]	12 to 70 [-11 to 21]	-4 to 70 [-20 to 21]	-4 to 70 [-20 to 21]	-4 to 70 [-20 to 21]	-4 to 70 [-20 to 21]

Notes:  
 AHRI Rated Conditions (Rated data is determined at a fixed compressor speed)  
 Conditions  
<sup>1</sup>Cooling (Indoor // Outdoor) °F 80 DB, 67 WB // 95 DB, 75 WB  
<sup>2</sup>Heating at 47°F (Indoor // Outdoor) °F 70 DB, 60 WB // 47 DB, 43 WB  
<sup>3</sup>Heating at 17°F (Indoor // Outdoor) °F 70 DB, 60 WB // 17 DB, 15 WB  
<sup>4</sup>Heating at 5°F (Indoor // Outdoor) °F 70 DB, 60 WB // 5 DB, 4 WB  
<sup>5</sup>Indoor units receive power from outdoor units through field-supplied interconnected wiring.  
<sup>6</sup>Wind baffles required to operate below 23°F DB in cooling mode. PUZ with wind baffle: 0° F - 115° F. Refer to wind baffle documentation for further information.  
 SEACOAST PROTECTION  
 • External Outer Panel: Phosphate coating + Acrylic-Enamel coating  
 • Fan Motor Support: Epoxy resin coating (at edge face)  
 • Separator Assembly; Valve Bed: Epoxy resin coating (at edge face)  
 • "Blue Fin" treatment is an anti-corrosion treatment that is applied to the condenser coil to protect it against airborne contaminants.

# PLA Model



## Hyper-heating

Indoor Unit				PLA-A24EA7	PLA-A30EA7	PLA-A36EA7	PLA-A42EA7
Outdoor Unit				PUZ-HA24NHA1	PUZ-HA30NKA	PUZ-HA36NKA	PUZ-HA42NKA1
Cooling	Capacity	Rated <sup>1</sup>	BTU/H	24,000	30,000	36,000	42,000
	Capacity Range	Min-Max	BTU/H	10,000–24,000	14,600–30,000	14,800–36,000	18,800–42,000
	Power Input	Rated <sup>1</sup>	W	1,710	2,120	2,750	3,920
	Moisture Removal	Pints/h		3.0	5.4	5.5	4.5
	Sensible Heat Factor			0.860	0.800	0.830	0.880
Heating	Capacity at 47°F	Rated <sup>2</sup>	BTU/H	26,000	32,000	38,000	48,000
	Capacity Range	Min-Max	BTU/H	10,000–28,000	14,200–34,000	16,700–40,000	17,000–54,000
	Power Input at 47°F	Rated <sup>2</sup>	W	1,700	2,260	2,650	4,210
	Capacity at 17°F	Rated <sup>3</sup>	BTU/H	17,300	20,600	24,200	40,500
		Max	BTU/H	26,000	32,000	38,000	48,000
	Capacity at 5°F	Max <sup>4</sup>	BTU/H	26,000	32,000	38,000	48,000
Capacity at -5°F	Max	BTU/H	—	—	—	—	
Efficiency	SEER			21.5	20.2	20.0	16.3
	EER			14.0	14.1	13.0	10.7
	HSPF			11.3	9.8	10.4	9.8
	COP			4.5	4.1	4.2	3.3
	ENERGY STAR® Certified			Yes	Yes	Yes	No
Indoor Unit	Air Flow Rate - Cooling (Quiet-Lo-Med-Hi-SHi)	Dry	CFM	530–640–710–810	570–670–780–880	670–850–1020–1200	740–920–1060–1200
	Air Flow Rate - Cooling (Quiet-Lo-Med-Hi-SHi)	Wet	CFM	490–600–670–770	530–630–740–840	630–810–980–1160	700–880–1020–1160
	Air Flow Rate - Heating (Quiet-Lo-Med-Hi-SHi)	Dry	CFM	530–640–710–810	570–670–780–880	670–850–1020–1200	740–920–1060–1200
	Sound Pressure Level (Quiet-Lo-Med-Hi-SHi)	Cooling	dB(A)	28–30–33–36	28–32–35–38	32–37–41–44	34–38–42–45
	Sound Pressure Level (Quiet-Lo-Med-Hi-SHi)	Heating	dB(A)	28–30–33–36	28–32–35–38	32–37–41–44	34–38–42–45
	External Static Pressure		In. W.G.	—	—	—	—
	Condensate Lift Mechanism	Max Distance	In. [mm]	33-7/16 [849]	33-7/16 [849]	33-7/16 [849]	33-7/16 [849]
		H	In. [mm]	11-3/4 // 1-9/16 [298 // 40]	11-3/4 // 1-9/16 [298 // 40]	11-3/4 // 1-9/16 [298 // 40]	11-3/4 // 1-9/16 [298 // 40]
		Dimensions	W	In. [mm]	33-1/16 // 37-13/32 [840 // 950]	33-1/16 // 37-13/32 [840 // 950]	33-1/16 // 37-13/32 [840 // 950]
		D	In. [mm]	33-1/16 // 37-13/32 [840 // 950]	33-1/16 // 37-13/32 [840 // 950]	33-1/16 // 37-13/32 [840 // 950]	33-1/16 // 37-13/32 [840 // 950]
Weight	lbs [kg]		56 // 11 [25 // 5]	56 // 11 [25 // 5]	56 // 11 [25 // 5]	56 // 11 [25 // 5]	
Outdoor Unit	MCA	A		17.0	24.0	26.0	36.0
	MOCP	A		27	40	42	44
	Dimensions	H	In. [mm]	37-1/8 [943]	52-11/16 [1338]	52-11/16 [1338]	52-11/16 [1338]
		W	In. [mm]	37-13/32 [950]	41-5/16 [1050]	41-5/16 [1050]	41-5/16 [1050]
		D	In. [mm]	14-3/16 [360]	14-3/16 [360]	14-3/16 [360]	14-3/16 [360]
	Weight	lbs [kg]		190 [86]	261 [118]	261 [118]	283 [128]
	Air Flow Rate (Cooling/Heating)	CFM		1940/1940	3880/3880	3880/3880	3319/3319
	Sound Pressure Level	Cooling	dB(A)	52	52	52	49
		Heating	dB(A)	53	53	53	51
	Piping	Diameter	Gas (O.D.)	In. [mm]	5/8 [15.88]	5/8 [15.88]	5/8 [15.88]
Liquid (O.D)			In. [mm]	3/8 [9.52]	3/8 [9.52]	3/8 [9.52]	3/8 [9.52]
Indoor Drain			In. [mm]	1-1/4 [32]	1-1/4 [32]	1-1/4 [32]	1-1/4 [32]
Max. Length		ft [m]		165 [50]	245 [75]	245 [75]	245 [75]
Max. Height	ft [m]		100 [30]	100 [30]	100 [30]	100 [30]	
Electrical	Outdoor-Indoor <sup>5</sup>	V, ph, Hz		208/230, 1, 60	208/230, 1, 60	208/230, 1, 60	208/230, 1, 60
	Recommended Breaker Size	A		25	35	35	40
Refrigerant Type				R410A	R410A	R410A	R410A
Guaranteed Temperature Operation Range	Cooling <sup>6</sup>	°F DB [°C DB]		23 to 115	23 to 115	23 to 115	23 to 115
	Heating	°F DB [°C DB]		-13 to 70	-13 to 70	-13 to 70	-13 to 70

Notes:  
 AHRI Rated Conditions <sup>1</sup>Cooling (Indoor // Outdoor) °F 80 DB, 67 WB // 95 DB, 75 WB  
 (Rated data is determined at a fixed compressor speed) <sup>2</sup>Heating at 47°F (Indoor // Outdoor) °F 70 DB, 60 WB // 47 DB, 43 WB  
 Conditions <sup>3</sup>Heating at 17°F (Indoor // Outdoor) °F 70 DB, 60 WB // 17 DB, 15 WB  
<sup>4</sup>Heating at 5°F (Indoor // Outdoor) °F 70 DB, 60 WB // 5 DB, 4 WB  
<sup>5</sup>Indoor units receive power from outdoor units through field-supplied interconnected wiring.  
<sup>6</sup>Wind baffles required to operate below 23°F DB in cooling mode. PUZ with wind baffle: 0° F - 115° F.





# PKA Model

Wall Mount



## Flat Panel & Pure White Finish

A flat panel design and pure white color that pairs with any interior.



PKA-A HA7



PKA-A KA7

## Compact Indoor Units

The updated product design boasts a significant size reduction compared to the previous model.

PKA-A12/18HA7 **\*REDUCED 3-5/8"**



\*Compared to PKA-A12/18GA previous model

PKA-A24/30KA7 **\*REDUCED 9-1/16"**



\*Compared to PKA-A24/30FA previous model

PKA-A36KA7 **\*REDUCED 20-1/16"**



\*Compared to PKA-A36FA previous model

## Energy Saving Performance

When contrasted with the previous model's performance, SEER and HSPF efficiencies improved, realizing industry-leading energy-saving features.

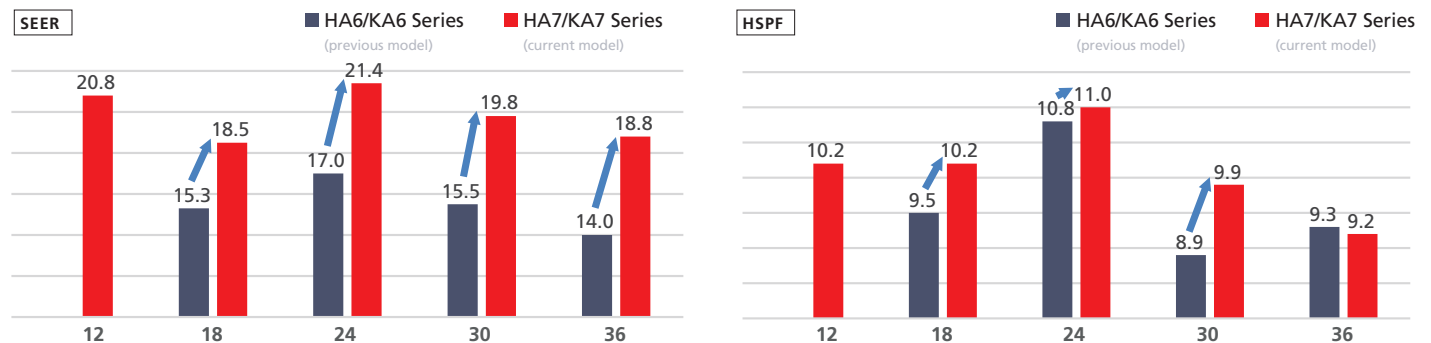

# PKA Model



## Model Selection

Indoor Unit

Outdoor Unit

Cooling Only



PUY-A12/18NKA7



PUY-A24/30NHA7



PUY-A36NKA7

Heat Pump



PKA-A12/18HA7



PKA-A24/30/36KA7



PUZ-A12/18NKA7



PUZ-A24/30NHA7



PUZ-A36NKA7

Hyper-heating



PUZ-HA24NH1



PUZ-HA30/36NKA

Remote Controller



\*optional  
PAR-40MAAU



\*optional  
PAC-YT53CRAU-J



\*optional



\*optional  
PAR-CT01MAU-SB



\*optional  
MHK2

# PKA Model



## Cooling Only

Indoor Unit				PKA-A12HA7	PKA-A18HA7	PKA-A24KA7	PKA-A30KA7	PKA-A36KA7
Outdoor Unit				PUY-A12NKA7(-BS)	PUY-A18NKA7(-BS)	PUY-A24NHA7(-BS)	PUY-A30NHA7(-BS)	PUY-A36NKA7(-BS)
Cooling	Capacity	Rated <sup>1</sup>	BTU/H	12,000	18,000	24,000	30,000	36,000
	Capacity Range	Min-Max	BTU/H	5,800–12,000	8,000–18,000	10,000–24,000	9,000–30,000	16,000–36,000
	Power Input	Rated <sup>1</sup>	W	1,000	1,820	1,960	3,150	3,330
	Moisture Removal	Pints/h		2.0	5.2	5.0	8.1	9.7
	Sensible Heat Factor			0.810	0.680	0.770	0.700	0.700
Heating	Capacity at 47°F	Rated	BTU/H	—	—	—	—	—
	Capacity Range	Min-Max	BTU/H	—	—	—	—	—
	Power Input at 47°F	Rated	W	—	—	—	—	—
	Capacity at 17°F	Rated	BTU/H	—	—	—	—	—
	Capacity at 17°F	Max	BTU/H	—	—	—	—	—
	Capacity at 5°F	Max	BTU/H	—	—	—	—	—
	Capacity at -5°F	Max	BTU/H	—	—	—	—	—
Efficiency	SEER			20.8	18.5	21.4	19.8	18.8
	EER			12.0	9.9	12.2	9.5	10.8
	HSPF			—	—	—	—	—
	COP			—	—	—	—	—
	ENERGY STAR® Certified			No	No	No	No	No
Indoor Unit	Air Flow Rate - Cooling (Quiet-Lo-Med-Hi-SHi)	Dry	CFM	320–370–425	320–370–425	635–705–775	635–705–775	705–810–920
	Air Flow Rate - Cooling (Quiet-Lo-Med-Hi-SHi)	Wet	CFM	290–335–380	290–335–380	570–635–700	570–635–700	635–730–830
	Air Flow Rate - Heating (Quiet-Lo-Med-Hi-SHi)	Dry	CFM	320–370–425	320–370–425	635–705–775	635–705–775	705–810–920
	Sound Pressure Level (Quiet-Lo-Med-Hi-SHi)	Cooling	dB(A)	36–40–43	36–40–43	39–42–45	39–42–45	43–46–49
	Sound Pressure Level (Quiet-Lo-Med-Hi-SHi)	Heating	dB(A)	36–40–43	36–40–43	39–42–45	39–42–45	43–46–49
	External Static Pressure		In. W.G.	—	—	—	—	—
	Condensate Lift Mechanism	Max Distance	In. [mm]	—	—	—	—	—
	Dimensions	H	In. [mm]	11-5/8 [295]	11-5/8 [295]	14-3/8 [365]	14-3/8 [365]	14-3/8 [365]
		W	In. [mm]	35-3/8 [898]	35-3/8 [898]	46-1/16 [1170]	46-1/16 [1170]	46-1/16 [1170]
		D	In. [mm]	9-13/16 [249]	9-13/16 [249]	11-5/8 [295]	11-5/8 [295]	11-5/8 [295]
Weight	lbs [kg]		29 [13]	29 [13]	46 [21]	46 [21]	46 [21]	
MCA	A		11.0	11.0	19.0	19.0	25.0	
MOCP	A		28	28	26	26	31	
Outdoor Unit	Dimensions	H	In. [mm]	24-13/16 [630]	24-13/16 [630]	37-1/8 [943]	37-1/8 [943]	52-11/16 [1338]
		W	In. [mm]	31-13/16 (+7/16) [809 (+62)]	31-13/16 (+7/16) [809 (+62)]	37-13/32 [950]	37-13/32 [950]	41-5/16 [1050]
		D	In. [mm]	11-3/16 [300]	11-3/16 [300]	13 (+1-3/16) [330 (+30)]	13 (+1-3/16) [330 (+30)]	13 (+1-3/16) [330 (+30)]
	Weight	lbs [kg]		92 [41]	99 [44]	151 [68]	151 [68]	211 [96]
	Air Flow Rate (Cooling/Heating)	CFM		1590/—	1590/—	1940/—	1940/—	3880/—
Sound Pressure Level	Cooling	dB(A)	44	44	47	47	52	
	Heating	dB(A)	—	—	—	—	—	
Piping	Diameter	Gas (O.D.)	In. [mm]	1/2 [12.7]	1/2 [12.7]	5/8 [15.88]	5/8 [15.88]	5/8 [15.88]
		Liquid (O.D.)	In. [mm]	1/4 [6.35]	1/4 [6.35]	3/8 [9.52]	3/8 [9.52]	3/8 [9.52]
		Indoor Drain	In. [mm]	5/8 [16]	5/8 [16]	5/8 [16]	5/8 [16]	5/8 [16]
	Max. Length	ft [m]		165 [50]	165 [50]	225 [68]	225 [68]	225 [68]
	Max. Height	ft [m]		100 [30]	100 [30]	100 [30]	100 [30]	100 [30]
Electrical	Outdoor-Indoor <sup>5</sup>	V, ph, Hz		208/230, 1, 60	208/230, 1, 60	208/230, 1, 60	208/230, 1, 60	208/230, 1, 60
	Recommended Breaker Size	A		15	15	25	25	30
Refrigerant Type				R410A	R410A	R410A	R410A	R410A
Guaranteed Temperature Operation Range	Cooling <sup>6</sup>	°F DB [°C DB]		-40 to 115 [-40.0 to 46.0]	-40 to 115 [-40.0 to 46.0]	-40 to 115 [-40.0 to 46.0]	-40 to 115 [-40.0 to 46.0]	-40 to 115 [-40.0 to 46.0]
	Heating	°F DB [°C DB]		—	—	—	—	—

Notes:  
 AHRI Rated Conditions <sup>1</sup>Cooling (Indoor // Outdoor) <sup>2</sup>°F 80 DB, 67 WB // 95 DB, 75 WB  
 (Rated data is determined at a fixed compressor speed)

- <sup>3</sup>Indoor units receive power from outdoor units through field-supplied interconnected wiring.  
<sup>4</sup>Wind baffles required to operate below 23°F DB in cooling mode. PUY with wind baffle: -40°F - 115°F. Refer to wind baffle documentation for further information.  
 SEACOAST PROTECTION  
 • External Outer Panel: Phosphate coating + Acrylic-Enamel coating  
 • Fan Motor Support: Epoxy resin coating (at edge face)  
 • Separator Assembly; Valve Bed: Epoxy resin coating (at edge face)  
 • "Blue Fin" treatment is an anti-corrosion treatment that is applied to the condenser coil to protect it against airborne contaminants.



# PKA Model



## Heat Pump

Indoor Unit				PKA-A12HA7	PKA-A18HA7	PKA-A24KA7	PKA-A30KA7	PKA-A36KA7
Outdoor Unit				PUZ-A12NKA7(-BS)	PUZ-A18NKA7(-BS)	PUZ-A24NHA7(-BS)	PUZ-A30NHA7(-BS)	PUZ-A36NKA7(-BS)
Cooling	Capacity	Rated <sup>1</sup>	BTU/H	12,000	18,000	24,000	30,000	36,000
	Capacity Range	Min-Max	BTU/H	5,800–12,000	8,000–18,000	10,000–24,000	9,000–30,000	16,000–36,000
	Power Input	Rated <sup>1</sup>	W	1,000	1,820	1,960	3,150	3,330
	Moisture Removal	Pints/h		2.0	5.2	5.0	8.1	9.7
	Sensible Heat Factor			0.810	0.680	0.770	0.700	0.700
Heating	Capacity at 47°F	Rated <sup>2</sup>	BTU/H	14,000	19,000	26,000	32,000	38,000
	Capacity Range	Min-Max	BTU/H	5,500–18,000	7,700–22,000	9,000–28,000	8,900–34,000	18,200–40,000
	Power Input at 47°F	Rated <sup>2</sup>	W	950	1,300	1,750	2,460	2,460
	Capacity at 17°F	Rated <sup>3</sup>	BTU/H	9,200	11,300	15,700	18,300	22,400
	Capacity at 5°F	Max <sup>4</sup>	BTU/H	11,100	13,900	18,300	21,000	25,900
	Capacity at -5°F	Max	BTU/H	10,600	11,800	15,200	—	—
Efficiency	SEER			20.8	18.5	21.4	19.8	18.8
	EER			12.0	9.9	12.2	9.5	10.8
	HSPF			10.2	10.2	11.0	9.9	9.2
	COP			4.31	4.28	4.35	3.81	4.52
	ENERGY STAR® Certified			No	No	No	No	No
Indoor Unit	Air Flow Rate - Cooling (Quiet-Lo-Med-Hi-SHi)	Dry	CFM	320–370–425	320–370–425	635–705–775	635–705–775	705–810–920
	Air Flow Rate - Cooling (Quiet-Lo-Med-Hi-SHi)	Wet	CFM	290–335–380	290–335–380	570–635–700	570–635–700	635–730–830
	Air Flow Rate - Heating (Quiet-Lo-Med-Hi-SHi)	Dry	CFM	320–370–425	320–370–425	635–705–775	635–705–775	705–810–920
	Sound Pressure Level (Quiet-Lo-Med-Hi-SHi)	Cooling	dB(A)	36–40–43	36–40–43	39–42–45	39–42–45	43–46–49
	Sound Pressure Level (Quiet-Lo-Med-Hi-SHi)	Heating	dB(A)	36–40–43	36–40–43	39–42–45	39–42–45	43–46–49
	External Static Pressure		In. W.G.	—	—	—	—	—
	Condensate Lift Mechanism	Max Distance	In. [mm]	—	—	—	—	—
	Dimensions	H	In. [mm]	11-5/8 [295]	11-5/8 [295]	14-3/8 [365]	14-3/8 [365]	14-3/8 [365]
		W	In. [mm]	35-3/8 [898]	35-3/8 [898]	46-1/16 [1170]	46-1/16 [1170]	46-1/16 [1170]
		D	In. [mm]	9-13/16 [249]	9-13/16 [249]	11-5/8 [295]	11-5/8 [295]	11-5/8 [295]
Weight	lbs [kg]		29 [13]	29 [13]	46 [21]	46 [21]	46 [21]	
Outdoor Unit	MCA	A		11.0	11.0	19.0	19.0	25.0
	MOCP	A		28	28	26	26	31
	Dimensions	H	In. [mm]	24-13/16 [630]	24-13/16 [630]	37-1/8 [943]	37-1/8 [943]	52-11/16 [1338]
		W	In. [mm]	31-13/16 (+7/16) [809 (+62)]	31-13/16 (+7/16) [809 (+62)]	37-13/32 [950]	37-13/32 [950]	41-5/16 [1050]
		D	In. [mm]	11-3/16 [300]	11-3/16 [300]	13 (+1-3/16) [330 (+30)]	13 (+1-3/16) [330 (+30)]	13 (+1-3/16) [330 (+30)]
	Weight	lbs [kg]		93 [42]	100 [45]	153 [69]	153 [69]	214 [97]
	Air Flow Rate (Cooling/Heating)	CFM		1590/1590	1590/1590	1940/1940	1940/1940	3880/3880
Sound Pressure Level	Cooling	dB(A)	44	44	47	47	52	
	Heating	dB(A)	46	46	48	48	53	
Piping	Diameter	Gas (O.D.)	In. [mm]	1/2 [12.7]	1/2 [12.7]	5/8 [15.88]	5/8 [15.88]	5/8 [15.88]
		Liquid (O.D)	In. [mm]	1/4 [6.35]	1/4 [6.35]	3/8 [9.52]	3/8 [9.52]	3/8 [9.52]
		Indoor Drain	In. [mm]	5/8 [16]	5/8 [16]	5/8 [16]	5/8 [16]	5/8 [16]
	Max. Length	ft [m]		100 [30]	100 [30]	165 [50]	165 [50]	165 [50]
Max. Height	ft [m]		100 [30]	100 [30]	100 [30]	100 [30]	100 [30]	
Electrical	Outdoor-Indoor <sup>5</sup>	V, ph, Hz		208/230, 1, 60	208/230, 1, 60	208/230, 1, 60	208/230, 1, 60	208/230, 1, 60
	Recommended Breaker Size	A		15	15	25	25	30
Refrigerant Type				R410A	R410A	R410A	R410A	R410A
Guaranteed Temperature Operation Range	Cooling <sup>6</sup>	°F DB [°C DB]		0 to 115 [-18.0 to 46.0]	0 to 115 [-18.0 to 46.0]	0 to 115 [-18.0 to 46.0]	0 to 115 [-18.0 to 46.0]	0 to 115 [-18.0 to 46.0]
	Heating	°F DB [°C DB]		12 to 70 [-11.0 to 21.0]	12 to 70 [-11.0 to 21.0]	-4 to 70 [-20.0 to 21.0]	-4 to 70 [-20.0 to 21.0]	-4 to 70 [-20.0 to 21.0]

Notes:  
 AHRI Rated Conditions  
 (Rated data is determined at a fixed compressor speed)  
 Conditions  
<sup>1</sup>Cooling (Indoor // Outdoor) °F 80 DB, 67 WB // 95 DB, 75 WB  
<sup>2</sup>Heating at 47°F (Indoor // Outdoor) °F 70 DB, 60 WB // 47 DB, 43 WB  
<sup>3</sup>Heating at 17°F (Indoor // Outdoor) °F 70 DB, 60 WB // 17 DB, 15 WB  
<sup>4</sup>Heating at 5°F (Indoor // Outdoor) °F 70 DB, 60 WB // 5 DB, 4 WB  
<sup>5</sup>Indoor units receive power from outdoor units through field-supplied interconnected wiring.  
<sup>6</sup>Wind baffles required to operate below 23°F DB in cooling mode. PUZ with wind baffle: 0° F - 115° F. Refer to wind baffle documentation for further information.  
 SEACOAST PROTECTION  
 • External Outer Panel: Phosphate coating + Acrylic-Enamel coating  
 • Fan Motor Support: Epoxy resin coating (at edge face)  
 • Separator Assembly, Valve Bed: Epoxy resin coating (at edge face)  
 • "Blue Fin" treatment is an anti-corrosion treatment that is applied to the condenser coil to protect it against airborne contaminants.

# PKA Model



## Hyper-heating

Indoor Unit				PKA-A24KA7	PKA-A30KA7	PKA-A36KA7
Outdoor Unit				PUZ-HA24NHA1	PUZ-HA30NKA	PUZ-HA36NKA
Cooling	Capacity	Rated <sup>1</sup>	BTU/H	24,000	30,000	33,600
	Capacity Range	Min-Max	BTU/H	10,000–24,000	14,600–30,000	14,700–36,000
	Power Input	Rated <sup>1</sup>	W	1,900	2,330	2,700
	Moisture Removal	Pints/h		5.0	7.5	9.3
	Sensible Heat Factor			0.770	0.720	0.690
Heating	Capacity at 47°F	Rated <sup>2</sup>	BTU/H	26,000	32,000	38,000
	Capacity Range	Min-Max	BTU/H	10,000–28,000	14,600–34,000	14,900–40,000
	Power Input at 47°F	Rated <sup>2</sup>	W	1,920	2,770	3,340
	Capacity at 17°F	Rated <sup>3</sup>	BTU/H	17,200	21,300	25,400
		Max	BTU/H	26,000	32,000	38,000
	Capacity at 5°F	Max <sup>4</sup>	BTU/H	26,000	32,000	38,000
Efficiency	SEER			19.5	18.5	18.5
	EER			12.65	12.8	11.6
	HSPF			10.6	9.6	10.0
	COP			3.96	3.38	3.33
	ENERGY STAR® Certified			Yes	Yes	No
Indoor Unit	Air Flow Rate - Cooling (Quiet-Lo-Med-Hi-SHi)	Dry	CFM	635–705–775	635–705–775	705–810–920
	Air Flow Rate - Cooling (Quiet-Lo-Med-Hi-SHi)	Wet	CFM	570–635–700	570–635–700	635–730–830
	Air Flow Rate - Heating (Quiet-Lo-Med-Hi-SHi)	Dry	CFM	635–705–775	635–705–775	705–810–920
	Sound Pressure Level (Quiet-Lo-Med-Hi-SHi)	Cooling	dB(A)	39–42–45	39–42–45	43–46–49
	Sound Pressure Level (Quiet-Lo-Med-Hi-SHi)	Heating	dB(A)	39–42–45	39–42–45	43–46–49
	External Static Pressure		In. W.G.	—	—	—
	Condensate Lift Mechanism	Max Distance	In. [mm]	—	—	—
	Dimensions	H	In. [mm]	14-3/8 [365]	14-3/8 [365]	14-3/8 [365]
		W	In. [mm]	46-1/16 [1170]	46-1/16 [1170]	46-1/16 [1170]
		D	In. [mm]	11-5/8 [295]	11-5/8 [295]	11-5/8 [295]
Weight		lbs [kg]	46 [21]	46 [21]	46 [21]	
Outdoor Unit	MCA	A		17.0	24.0	26.0
	MOCF	A		27	40	42
	Dimensions	H	In. [mm]	37-1/8 [943]	52-11/16 [1338]	52-11/16 [1338]
		W	In. [mm]	37-13/32 [950]	41-5/16 [1050]	41-5/16 [1050]
		D	In. [mm]	14-3/16 [360]	14-3/16 [360]	14-3/16 [360]
	Weight		lbs [kg]	190 [86]	261 [118]	261 [118]
	Air Flow Rate (Cooling/Heating)		CFM	1940/1940	3880/3880	3880/3880
	Sound Pressure Level	Cooling	dB(A)	52	52	52
		Heating	dB(A)	53	53	53
	Piping	Diameter	Gas (O.D.)	In. [mm]	5/8 [15.88]	5/8 [15.88]
Liquid (O.D)			In. [mm]	3/8 [9.52]	3/8 [9.52]	3/8 [9.52]
Indoor Drain			In. [mm]	5/8 [16]	5/8 [16]	5/8 [16]
Max. Length			ft [m]	165 [50]	245 [75]	245 [75]
Max. Height		ft [m]	100 [30]	100 [30]	100 [30]	
Electrical	Outdoor-Indoor <sup>5</sup>	V, ph, Hz		208/230, 1, 60	208/230, 1, 60	208/230, 1, 60
	Recommended Breaker Size	A		25	35	35
Refrigerant Type				R410A	R410A	R410A
Guaranteed Temperature Operation Range	Cooling <sup>6</sup>	°F DB [°C DB]		0 to 115 [-10.0 to 46.0]	0 to 115 [-10.0 to 46.0]	0 to 115 [-10.0 to 46.0]
	Heating	°F DB [°C DB]		-13 to 75 [-25.0 to 24.0]	-13 to 75 [-25.0 to 24.0]	-13 to 75 [-25.0 to 24.0]

Notes:  
 AHRI Rated Conditions (Rated data is determined at a fixed compressor speed)  
 Conditions  
<sup>1</sup>Cooling (Indoor // Outdoor) °F 80 DB, 67 WB // 95 DB, 75 WB  
<sup>2</sup>Heating at 47°F (Indoor // Outdoor) °F 70 DB, 60 WB // 47 DB, 43 WB  
<sup>3</sup>Heating at 17°F (Indoor // Outdoor) °F 70 DB, 60 WB // 17 DB, 15 WB  
<sup>4</sup>Heating at 5°F (Indoor // Outdoor) °F 70 DB, 60 WB // 5 DB, 4 WB  
<sup>5</sup>Indoor units receive power from outdoor units through field-supplied interconnected wiring.  
<sup>6</sup>Wind baffles required to operate below 23°F DB in cooling mode. PUZ with wind baffle: 0° F - 115° F.



# PVA Model

Multi-position Air Handler

## Multi-position Installation Options

The PVA Model air handler is multi-positional\* offering up, down, left, or right airflow options, making it ideal for tight and unique spaces. (\*CMA accessory recommended for downflow applications.)



## High Energy Efficiency

The PVA Model has high SEER ratings and is highly energy efficient compared to outdated unitary air conditioners.

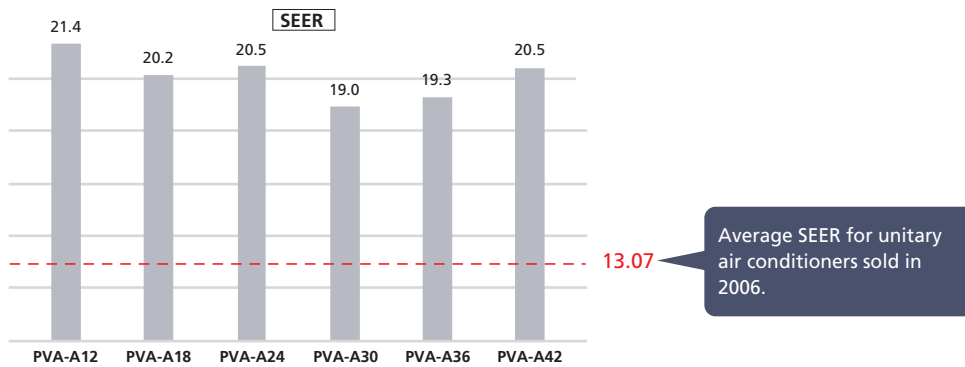

## Interlocking Function

The PVA Model has an output terminal which allows it to interlock with other appliances such as humidifiers and dehumidifiers.

## Thermostat Control

Using the Thermostat Interface (PAC-US444CN-1), the user can replace their unitary air conditioner without changing the thermostat.



# PVA Model



## Model Selection

Indoor Unit



PVA-A12/18/24/30/36/42AA7

Outdoor Unit

Cooling Only



PUY-A12/18NKA7



PUY-A24/30NHA7



PUY-A36/42NKA7

Heat Pump



PUZ-A12/18NKA7



PUZ-A24/30NHA7



PUZ-A36/42NKA7

Hyper-heating



PUZ-HA24NHA1



PUZ-HA30/36NKA



PUZ-HA42NKA1

## Remote Controller



\*optional  
PAR-40MAAU



\*optional  
PAC-YT53CRAU-J



\*optional



\*optional  
PAR-CT01MAU-SB



\*optional  
MHK2

# PVA Model



## Cooling Only

Indoor Unit				PVA-A12AA7	PVA-A18AA7	PVA-A24AA7	PVA-A30AA7	PVA-A36AA7	PVA-A42AA7
Outdoor Unit				PUY-A12NKA7(-BS)	PUY-A18NKA7(-BS)	PUY-A24NHA7(-BS)	PUY-A30NHA7(-BS)	PUY-A36NKA7(-BS)	PUY-A42NKA7(-BS)
Cooling	Capacity	Rated <sup>1</sup>	BTU/H	12,000	18,000	24,000	30,000	36,000	42,000
	Capacity Range	Min-Max	BTU/H	4,800–12,000	7,000–18,000	10,000–24,000	10,000–30,000	14,600–36,000	15,000–42,000
	Power Input	Rated <sup>1</sup>	W	890	1,570	1,960	3,000	3,250	4,150
	Moisture Removal	Pints/h		1.2	2.4	3.0	5.4	4.5	7.9
	Sensible Heat Factor			0.770	0.760	0.830	0.740	0.770	0.810
Heating	Capacity at 47°F	Rated	BTU/H	—	—	—	—	—	—
	Capacity Range	Min-Max	BTU/H	—	—	—	—	—	—
	Power Input at 47°F	Rated	W	—	—	—	—	—	—
	Capacity at 17°F	Rated	BTU/H	—	—	—	—	—	—
	Capacity at 5°F	Max	BTU/H	—	—	—	—	—	—
	Capacity at -5°F	Max	BTU/H	—	—	—	—	—	—
	SEER			21.4	20.2	20.5	19.0	19.3	18.0
EER			13.4	11.4	12.2	10.0	9.8	10.1	
HSPF			—	—	—	—	—	—	
COP			—	—	—	—	—	—	
ENERGY STAR® Certified			Yes	No	No	No	No	No	
Indoor Unit	Air Flow Rate - Cooling (Quiet-Lo-Med-Hi-SHi)	Dry	CFM	280–340–400	515–625–735	613–744–875	613–744–875	788–956–1125	1040–1262–1485
	Air Flow Rate - Cooling (Quiet-Lo-Med-Hi-SHi)	Wet	CFM	—	—	—	—	—	—
	Air Flow Rate - Heating (Quiet-Lo-Med-Hi-SHi)	Dry	CFM	280–340–400	515–625–735	613–744–875	613–744–875	788–956–1125	1040–1262–1485
	Sound Pressure Level (Quiet-Lo-Med-Hi-SHi)	Cooling	dB(A)	27–31–35	28–33–36	30–34–38	30–34–38	30–34–38	36–40–44
	Sound Pressure Level (Quiet-Lo-Med-Hi-SHi)	Heating	dB(A)	27–31–35	28–33–36	30–34–38	30–34–38	30–34–38	36–40–44
	External Static Pressure	In. W.G.		0.30–0.5–0.8	0.30–0.5–0.8	0.30–0.5–0.8	0.30–0.5–0.8	0.30–0.5–0.8	0.30–0.5–0.8
	Condensate Lift Mechanism	Max Distance	In. [mm]	—	—	—	—	—	—
	Dimensions	H	In. [mm]	50-1/4 [1275]	50-1/4 [1275]	54-1/4 [1378]	54-1/4 [1378]	59-1/2 [1511]	59-1/2 [1511]
		W	In. [mm]	17 [432]	17 [432]	21 [534]	21 [534]	25 [635]	25 [635]
		D	In. [mm]	21-5/8 [548]	21-5/8 [548]	21-5/8 [548]	21-5/8 [548]	21-5/8 [548]	21-5/8 [548]
Weight	lbs [kg]		113 [51]	113 [51]	141 [64]	141 [64]	172 [78]	172 [78]	
MCA	A		11.0	11.0	19.0	19.0	25.0	25.0	
MOCP	A		28	28	26	26	31	31	
Outdoor Unit	Dimensions	H	In. [mm]	24-13/16 [630]	24-13/16 [630]	37-1/8 [943]	37-1/8 [943]	52-11/16 [1338]	52-11/16 [1338]
		W	In. [mm]	31-13/16 (+7/16) [809 (+62)]	31-13/16 (+7/16) [809 (+62)]	37-13/32 [950]	37-13/32 [950]	41-5/16 [1050]	41-5/16 [1050]
		D	In. [mm]	11-3/16 [300]	11-3/16 [300]	13 (+1-3/16) [330 (+30)]	13 (+1-3/16) [330 (+30)]	13 (+1-3/16) [330 (+30)]	13 (+1-3/16) [330 (+30)]
	Weight	lbs [kg]		92 [41]	99 [44]	151 [68]	151 [68]	211 [96]	211 [96]
	Air Flow Rate (Cooling/Heating)	CFM		1590/—	1590/—	1940/—	1940/—	3880/—	3880/—
Sound Pressure Level	Cooling	dB(A)	44	44	47	47	52	52	
	Heating	dB(A)	—	—	—	—	—	—	
Piping	Diameter	Gas (O.D.)	In. [mm]	1/2 [12.7]	1/2 [12.7]	5/8 [15.88]	5/8 [15.88]	5/8 [15.88]	5/8 [15.88]
		Liquid (O.D)	In. [mm]	1/4 [6.35]	1/4 [6.35]	3/8 [9.52]	3/8 [9.52]	3/8 [9.52]	3/8 [9.52]
		Indoor Drain	In. [mm]	3/4 FPT [19.05]	3/4 FPT [19.05]	3/4 FPT [19.05]	3/4 FPT [19.05]	3/4 FPT [19.05]	3/4 FPT [19.05]
	Max. Length	ft [m]		165 [50]	165 [50]	225 [68]	225 [68]	225 [68]	225 [68]
Max. Height	ft [m]		100 [30]	100 [30]	100 [30]	100 [30]	100 [30]	100 [30]	
Electrical	Outdoor-Indoor <sup>5</sup>	V, ph, Hz		208/230, 1, 60	208/230, 1, 60	208/230, 1, 60	208/230, 1, 60	208/230, 1, 60	208/230, 1, 60
	Recommended Breaker Size	A		15	15	25	25	30	30
Refrigerant Type				R410A	R410A	R410A	R410A	R410A	R410A
Guaranteed Temperature Operation Range	Cooling <sup>6</sup>	°F DB [°C DB]		-40 to 115 [-40.0 to 46.0]	-40 to 115 [-40.0 to 46.0]	-40 to 115 [-40.0 to 46.0]	-40 to 115 [-40.0 to 46.0]	-40 to 115 [-40.0 to 46.0]	-40 to 115 [-40.0 to 46.0]
	Heating	°F DB [°C DB]		—	—	—	—	—	—

Notes:  
 AHRI Rated Conditions <sup>1</sup>Cooling (Indoor // Outdoor) <sup>4</sup>F 80 DB, 67 WB // 95 DB, 75 WB  
 (Rated data is determined at a fixed compressor speed)

<sup>5</sup>Indoor units receive power from outdoor units through field-supplied interconnected wiring.  
<sup>6</sup>Wind baffles required to operate below 23°F DB in cooling mode. PUY with wind baffle: -40°F - 115°F. Refer to wind baffle documentation for further information.

### SEACOAST PROTECTION

- External Outer Panel: Phosphate coating + Acrylic-Enamel coating
- Fan Motor Support: Epoxy resin coating (at edge face)
- Separator Assembly; Valve Bed: Epoxy resin coating (at edge face)
- "Blue Fin" treatment is an anti-corrosion treatment that is applied to the condenser coil to protect it against airborne contaminants.

# PVA Model



## Heat Pump

Indoor Unit				PVA-A12AA7	PVA-A18AA7	PVA-A24AA7	PVA-A30AA7	PVA-A36AA7	PVA-A42AA7
Outdoor Unit				PUZ-A12NKA7(-BS)	PUZ-A18NKA7(-BS)	PUZ-A24NHA7(-BS)	PUZ-A30NHA7(-BS)	PUZ-A36NKA7(-BS)	PUZ-A42NKA7(-BS)
Cooling	Capacity	Rated <sup>1</sup>	BTU/H	12,000	18,000	24,000	30,000	36,000	42,000
	Capacity Range	Min-Max	BTU/H	4,800–12,000	7,000–18,000	10,000–24,000	10,000–30,000	14,600–36,000	15,000–42,000
	Power Input	Rated <sup>1</sup>	W	890	1,570	1,960	3,000	3,250	4,150
	Moisture Removal	Pints/h		1.2	2.4	3.0	5.4	4.5	7.9
	Sensible Heat Factor			0.770	0.760	0.830	0.740	0.770	0.810
Heating	Capacity at 47°F	Rated <sup>2</sup>	BTU/H	14,000	19,000	26,000	32,000	38,000	46,000
	Capacity Range	Min-Max	BTU/H	5,700–19,000	7,700–23,000	12,000–28,000	12,000–34,000	17,700–42,000	18,100–48,000
	Power Input at 47°F	Rated <sup>2</sup>	W	1,070	1,470	1,920	2,640	3,030	3,900
	Capacity at 17°F	Rated <sup>3</sup>	BTU/H	9,900	12,000	15,000	18,000	24,000	28,400
	Capacity at 5°F	Max <sup>4</sup>	BTU/H	—	—	14,500	17,200	23,900	26,800
	Capacity at -5°F	Max	BTU/H	—	—	—	—	—	—
Efficiency	SEER			21.4	20.2	20.5	19.0	19.3	18.0
	EER			13.4	11.4	12.2	10.0	9.8	10.1
	HSPF			10.3	10.4	9.3	10.0	9.5	9.3
	COP			3.82	3.78	3.96	3.54	3.66	3.44
	ENERGY STAR® Certified			Yes	No	No	No	No	No
Indoor Unit	Air Flow Rate - Cooling (Quiet-Lo-Med-Hi-SHi)	Dry	CFM	280–340–400	515–625–735	613–744–875	613–744–875	788–956–1125	1040–1262–1485
	Air Flow Rate - Cooling (Quiet-Lo-Med-Hi-SHi)	Wet	CFM	—	—	—	—	—	—
	Air Flow Rate - Heating (Quiet-Lo-Med-Hi-SHi)	Dry	CFM	280–340–400	515–625–735	613–744–875	613–744–875	788–956–1125	1040–1262–1485
	Sound Pressure Level (Quiet-Lo-Med-Hi-SHi)	Cooling	dB(A)	27–31–35	28–33–36	30–34–38	30–34–38	30–34–38	36–40–44
	Sound Pressure Level (Quiet-Lo-Med-Hi-SHi)	Heating	dB(A)	27–31–35	28–33–36	30–34–38	30–34–38	30–34–38	36–40–44
	External Static Pressure		In. W.G.	0.30–0.5–0.8	0.30–0.5–0.8	0.30–0.5–0.8	0.30–0.5–0.8	0.30–0.5–0.8	0.30–0.5–0.8
	Condensate Lift Mechanism	Max Distance	In. [mm]	—	—	—	—	—	—
	Dimensions	H	In. [mm]	50-1/4 [1275]	50-1/4 [1275]	54-1/4 [1378]	54-1/4 [1378]	59-1/2 [1511]	59-1/2 [1511]
		W	In. [mm]	17 [432]	17 [432]	21 [534]	21 [534]	25 [635]	25 [635]
		D	In. [mm]	21-5/8 [548]	21-5/8 [548]	21-5/8 [548]	21-5/8 [548]	21-5/8 [548]	21-5/8 [548]
Weight	lbs [kg]		113 [51]	113 [51]	141 [64]	141 [64]	172 [78]	172 [78]	
Outdoor Unit	MCA	A		11.0	11.0	19.0	19.0	25.0	25.0
	MOCF	A		28	28	26	26	31	31
	Dimensions	H	In. [mm]	24-13/16 [630]	24-13/16 [630]	37-1/8 [943]	37-1/8 [943]	52-11/16 [1338]	52-11/16 [1338]
		W	In. [mm]	31-13/16 (+7/16) [809 (+62)]	31-13/16 (+7/16) [809 (+62)]	37-13/32 [950]	37-13/32 [950]	41-5/16 [1050]	41-5/16 [1050]
		D	In. [mm]	11-3/16 [300]	11-3/16 [300]	13 (+1-3/16) [330 (+30)]	13 (+1-3/16) [330 (+30)]	13 (+1-3/16) [330 (+30)]	13 (+1-3/16) [330 (+30)]
	Weight	lbs [kg]		93 [42]	100 [45]	153 [69]	153 [69]	214 [97]	214 [97]
	Air Flow Rate (Cooling/Heating)	CFM		1590/1590	1590/1590	1940/1940	1940/1940	3880/3880	3880/3880
	Sound Pressure Level	Cooling	dB(A)	44	44	47	47	52	52
		Heating	dB(A)	46	46	48	48	53	53
	Piping	Diameter	Gas (O.D.)	In. [mm]	1/2 [12.7]	1/2 [12.7]	5/8 [15.88]	5/8 [15.88]	5/8 [15.88]
Liquid (O.D)			In. [mm]	1/4 [6.35]	1/4 [6.35]	3/8 [9.52]	3/8 [9.52]	3/8 [9.52]	3/8 [9.52]
Indoor Drain			In. [mm]	3/4 FPT [19.05]	3/4 FPT [19.05]	3/4 FPT [19.05]	3/4 FPT [19.05]	3/4 FPT [19.05]	3/4 FPT [19.05]
Max. Length		ft [m]		100 [30]	100 [30]	165 [50]	165 [50]	165 [50]	165 [50]
Max. Height	ft [m]		100 [30]	100 [30]	100 [30]	100 [30]	100 [30]	100 [30]	
Electrical	Outdoor-Indoor <sup>5</sup>	V, ph, Hz		208/230, 1, 60	208/230, 1, 60	208/230, 1, 60	208/230, 1, 60	208/230, 1, 60	208/230, 1, 60
	Recommended Breaker Size	A		15	15	25	25	30	30
Refrigerant Type				R410A	R410A	R410A	R410A	R410A	R410A
Guaranteed Temperature Operation Range	Cooling <sup>6</sup>	°F DB [°C DB]		0 to 115 [-18.0 to 46.0]	0 to 115 [-18.0 to 46.0]	0 to 115 [-18.0 to 46.0]	0 to 115 [-18.0 to 46.0]	0 to 115 [-18.0 to 46.0]	0 to 115 [-18.0 to 46.0]
	Heating	°F DB [°C DB]		12 to 70 [-11.0 to 21.0]	12 to 70 [-11.0 to 21.0]	-4 to 70 [-20.0 to 21.0]	-4 to 70 [-20.0 to 21.0]	-4 to 70 [-20.0 to 21.0]	-4 to 70 [-20.0 to 21.0]

Notes:  
 AHRI Rated Conditions (Rated data is determined at a fixed compressor speed)  
<sup>1</sup>Cooling (Indoor // Outdoor) °F 80 DB, 67 WB // 95 DB, 75 WB  
<sup>2</sup>Heating at 47°F (Indoor // Outdoor) °F 70 DB, 60 WB // 47 DB, 43 WB  
<sup>3</sup>Heating at 17°F (Indoor // Outdoor) °F 70 DB, 60 WB // 17 DB, 15 WB  
<sup>4</sup>Heating at 5°F (Indoor // Outdoor) °F 70 DB, 60 WB // 5 DB, 4 WB  
<sup>5</sup>Indoor units receive power from outdoor units through field-supplied interconnected wiring.  
<sup>6</sup>Wind baffles required to operate below 23°F DB in cooling mode. PUZ with wind baffle: 0° F - 115° F. Refer to wind baffle documentation for further information.  
 SEACOAST PROTECTION  
 • External Outer Panel: Phosphate coating + Acrylic-Enamel coating  
 • Fan Motor Support: Epoxy resin coating (at edge face)  
 • Separator Assembly, Valve Bed: Epoxy resin coating (at edge face)  
 • "Blue Fin" treatment is an anti-corrosion treatment that is applied to the condenser coil to protect it against airborne contaminants.

# PVA Model



## Hyper-heating

Indoor Unit				PVA-A24AA7	PVA-A30AA7	PVA-A36AA7	PVA-A42AA7
Outdoor Unit				PUZ-HA24NHA1	PUZ-HA30NKA	PUZ-HA36NKA	PUZ-HA42NKA1
Cooling	Capacity	Rated <sup>1</sup>	BTU/H	24,000	30,000	33,000	42,000
	Capacity Range	Min-Max	BTU/H	10,000–24,000	14,800–30,000	15,500–36,000	17,000–42,000
	Power Input	Rated <sup>1</sup>	W	2,100	2,300	2,500	3,960
	Moisture Removal		Pints/h	3.7	5.9	3.8	5.3
	Sensible Heat Factor			0.830	0.780	0.870	0.860
Heating	Capacity at 47°F	Rated <sup>2</sup>	BTU/H	26,000	32,000	38,000	48,000
	Capacity Range	Min-Max	BTU/H	10,000–28,000	14,800–34,000	18,600–40,000	23,900–54,000
	Power Input at 47°F	Rated <sup>2</sup>	W	1,980	2,460	2,850	3,850
	Capacity at 17°F	Rated <sup>3</sup>	BTU/H	17,500	21,000	24,600	38,500
		Max	BTU/H	26,000	32,000	38,000	48,000
	Capacity at 5°F	Max <sup>4</sup>	BTU/H	26,000	32,000	38,000	48,000
	Capacity at -5°F	Max	BTU/H	—	—	—	—
Efficiency	SEER			19.0	18.0	18.2	15.4
	EER			11.4	13.0	13.0	10.6
	HSPF			10.4	9.8	11.2	10.0
	COP			3.8	3.8	3.9	3.7
	ENERGY STAR® Certified			No	Yes	Yes	No
Indoor Unit	Air Flow Rate - Cooling (Quiet-Lo-Med-Hi-SHi)	Dry	CFM	613–744–875	613–744–875	788–956–1125	1040–1262–1485
	Air Flow Rate - Cooling (Quiet-Lo-Med-Hi-SHi)	Wet	CFM	—	—	—	—
	Air Flow Rate - Heating (Quiet-Lo-Med-Hi-SHi)	Dry	CFM	613–744–875	613–744–875	788–956–1125	1040–1262–1485
	Sound Pressure Level (Quiet-Lo-Med-Hi-SHi)	Cooling	dB(A)	30–34–38	30–34–38	30–34–38	36–40–44
	Sound Pressure Level (Quiet-Lo-Med-Hi-SHi)	Heating	dB(A)	30–34–38	30–34–38	30–34–38	36–40–44
	External Static Pressure		In. W.G.	0.30–0.5–0.8	0.30–0.5–0.8	0.30–0.5–0.8	0.30–0.5–0.8
	Condensate Lift Mechanism	Max Distance	In. [mm]	—	—	—	—
	Dimensions	H	In. [mm]	54-1/4 [1378]	54-1/4 [1378]	59-1/2 [1511]	59-1/2 [1511]
		W	In. [mm]	21 [534]	21 [534]	25 [635]	25 [635]
		D	In. [mm]	21-5/8 [548]	21-5/8 [548]	21-5/8 [548]	21-5/8 [548]
Weight		lbs [kg]	141 [64]	141 [64]	172 [78]	172 [78]	
Outdoor Unit	MCA	A		17.0	24.0	24.0	36.0
	MOCP	A		27	40	40	44
	Dimensions	H	In. [mm]	37-1/8 [943]	52-11/16 [1338]	52-11/16 [1338]	52-11/16 [1338]
		W	In. [mm]	37-13/32 [950]	41-5/16 [1050]	41-5/16 [1050]	41-5/16 [1050]
		D	In. [mm]	14-3/16 [360]	14-3/16 [360]	14-3/16 [360]	14-3/16 [360]
	Weight		lbs [kg]	190 [86]	261 [118]	261 [118]	283 [128]
	Air Flow Rate (Cooling/Heating)		CFM	1940/1940	3880/3880	3880/3880	3319/3319
	Sound Pressure Level	Cooling	dB(A)	52	52	52	49
		Heating	dB(A)	53	53	53	51
	Piping	Diameter	Gas (O.D.)	In. [mm]	5/8 [15.88]	5/8 [15.88]	5/8 [15.88]
Liquid (O.D)			In. [mm]	3/8 [9.52]	3/8 [9.52]	3/8 [9.52]	3/8 [9.52]
Indoor Drain			In. [mm]	3/4 FPT [19.05]	3/4 FPT [19.05]	3/4 FPT [19.05]	3/4 FPT [19.05]
Max. Length			ft [m]	165 [50]	245 [75]	245 [75]	245 [75]
Max. Height		ft [m]	100 [30]	100 [30]	100 [30]	100 [30]	
Electrical	Outdoor-Indoor <sup>5</sup>	V, ph, Hz		208/230, 1, 60	208/230, 1, 60	208/230, 1, 60	208/230, 1, 60
	Recommended Breaker Size	A		25	35	35	40
Refrigerant Type				R410A	R410A	R410A	R410A
Guaranteed Temperature Operation Range	Cooling <sup>6</sup>	°F DB [°C DB]		0 to 115 [-18.0 to 46.0]	0 to 115 [-18.0 to 46.0]	0 to 115 [-18.0 to 46.0]	0 to 115 [-18.0 to 46.0]
	Heating	°F DB [°C DB]		-13 to 75 [-25.0 to 24.0]	-13 to 75 [-25.0 to 24.0]	-13 to 75 [-25.0 to 24.0]	-13 to 75 [-25.0 to 24.0]

Notes:  
 AHRI Rated Conditions  
 (Rated data is determined at a fixed compressor speed)  
 Conditions  
<sup>1</sup>Cooling (Indoor // Outdoor) °F 80 DB, 67 WB // 95 DB, 75 WB  
<sup>2</sup>Heating at 47°F (Indoor // Outdoor) °F 70 DB, 60 WB // 47 DB, 43 WB  
<sup>3</sup>Heating at 17°F (Indoor // Outdoor) °F 70 DB, 60 WB // 17 DB, 15 WB  
<sup>4</sup>Heating at 5°F (Indoor // Outdoor) °F 70 DB, 60 WB // 5 DB, 4 WB  
<sup>5</sup>Indoor units receive power from outdoor units through field-supplied interconnected wiring.  
<sup>6</sup>Wind baffles required to operate below 23°F DB in cooling mode. PUZ with wind baffle: 0° F - 115° F.





# PEAD Model

Mid Static Horizontal-ducted

## Compact Indoor Units

The height is only 9-7/8" for all sizes of this model ranging from 12 to 42 KBTU/H. Its compact size allows for the unit installations in low ceilings with minimal clearance space.

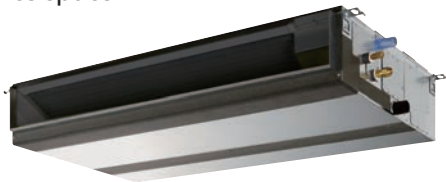

## External Static Pressure

External static pressure conversion can be set up to five settings. Capable of being set to a maximum of 0.60 In.W.G., units are applicable to a wide range of building types.

Model	12	18	24	30	36	42
PEAD-AA7	0.14-0.20-0.28-0.40-0.60 In. W.G.					

## High Energy Efficiency

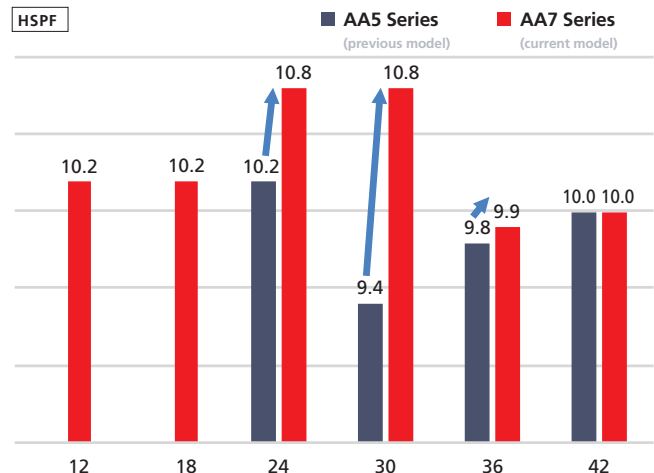
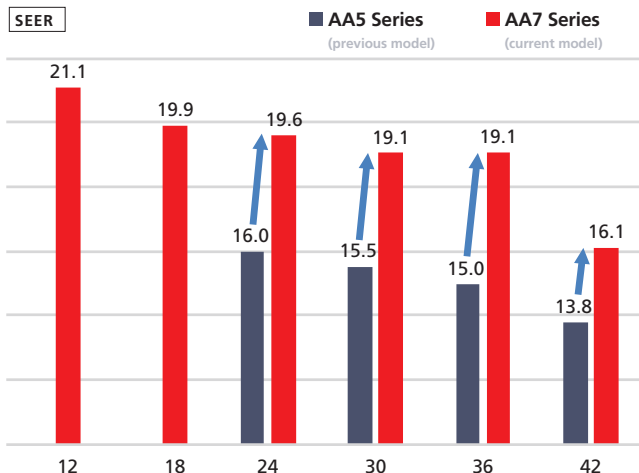

## Built-in Drain Lift Mechanism

All sizes feature a built-in drain lift mechanism for the removal of condensate. A fail-safe mechanism recognizes a high liquid level in the condensate pan and turns off the indoor fan and the outdoor unit compressor to prevent overflow.

# PEAD Model



## Model Selection

Indoor Unit

Outdoor Unit

Cooling Only



PUY-A12/18NKA7



PUY-A24/30NHA7



PUY-A36/42NKA7

Heat Pump



PEAD-A12/18/24/30/36/42AA7



PUZ-A12/18NKA7



PUZ-A24/30NHA7



PUZ-A36/42NKA7

Hyper-heating



PUZ-HA24NHA1



PUZ-HA30/36NKA



PUZ-HA42NKA1

Remote Controller



\*optional  
PAR-40MAAU



\*optional  
PAC-YT53CRAU-J



\*optional



\*optional  
PAR-CT01MAU-SB



\*optional  
MHK2

# PEAD Model



## Cooling Only

Indoor Unit			PEAD-A12AA7	PEAD-A18AA7	PEAD-A24AA7	PEAD-A30AA7	PEAD-A36AA7	PEAD-A42AA7	
Outdoor Unit			PUY-A12NKA7(-BS)	PUY-A18NKA7(-BS)	PUY-A24NHA7(-BS)	PUY-A30NHA7(-BS)	PUY-A36NKA7(-BS)	PUY-A42NKA7(-BS)	
Cooling	Capacity	Rated <sup>1</sup>	BTU/H	12,000	18,000	24,000	30,000	36,000	42,000
	Capacity Range	Min-Max	BTU/H	5,000–12,000	8,000–18,000	10,000–24,000	9,000–30,000	16,000–36,000	16,000–42,000
	Power Input	Rated <sup>1</sup>	W	920	1,660	2,050	3,000	3,000	3,920
	Moisture Removal	Pints/h		1.8	3.7	6.9	8.6	8.1	9.0
	Sensible Heat Factor			0.830	0.770	0.680	0.680	0.750	0.760
Heating	Capacity at 47°F	Rated	BTU/H	—	—	—	—	—	—
	Capacity Range	Min-Max	BTU/H	—	—	—	—	—	—
	Power Input at 47°F	Rated	W	—	—	—	—	—	—
	Capacity at 17°F	Rated	BTU/H	—	—	—	—	—	—
	Capacity at 5°F	Max	BTU/H	—	—	—	—	—	—
	Capacity at -5°F	Max	BTU/H	—	—	—	—	—	—
Efficiency	SEER			21.1	19.9	19.6	19.1	19.1	16.1
	EER			13.0	10.8	11.7	10.0	12.0	10.7
	HSPF			—	—	—	—	—	—
	COP			—	—	—	—	—	—
	ENERGY STAR® Certified			Yes	No	No	No	No	No
Indoor Unit	Air Flow Rate - Cooling (Quiet-Lo-Med-Hi-SHi)	Dry	CFM	353–424–494	424–512–600	512–635–741	618–742–883	847–1024–1201	1042–1254–1483
	Air Flow Rate - Cooling (Quiet-Lo-Med-Hi-SHi)	Wet	CFM	318–382–445	382–461–540	461–572–667	556–668–795	762–922–1081	1002–1214–1443
	Air Flow Rate - Heating (Quiet-Lo-Med-Hi-SHi)	Dry	CFM	353–424–494	424–512–600	512–635–741	618–742–883	847–1024–1201	1042–1254–1483
	Sound Pressure Level (Quiet-Lo-Med-Hi-SHi)	Cooling	dB(A)	28–30–34	30–33–37	30–33–37	30–34–39	33–38–42	36–40–44
	Sound Pressure Level (Quiet-Lo-Med-Hi-SHi)	Heating	dB(A)	28–30–34	30–33–37	30–33–37	30–34–39	33–38–42	36–40–44
	External Static Pressure		In. W.G.	0.14–0.2–0.28–0.4–0.6	0.14–0.2–0.28–0.4–0.6	0.14–0.2–0.28–0.4–0.6	0.14–0.2–0.28–0.4–0.6	0.14–0.2–0.28–0.4–0.6	0.14–0.2–0.28–0.4–0.6
	Condensate Lift Mechanism	Max Distance	In. [mm]	27-9/16 [700]	27-9/16 [700]	27-9/16 [700]	27-9/16 [700]	27-9/16 [700]	27-9/16 [700]
	Dimensions	H	In. [mm]	9-7/8 [250]	9-7/8 [250]	9-7/8 [250]	9-7/8 [250]	9-7/8 [250]	9-7/8 [250]
		W	In. [mm]	35-7/16 [900]	35-7/16 [900]	43-5/16 [1100]	43-5/16 [1100]	55-1/8 [1400]	55-1/8 [1400]
		D	In. [mm]	28-7/8 [732]	28-7/8 [732]	28-7/8 [732]	28-7/8 [732]	28-7/8 [732]	28-7/8 [732]
Weight	lbs [kg]		58 [26]	62 [28]	69 [31]	69 [31]	86 [39]	91 [41]	
Outdoor Unit	MCA	A		11.0	11.0	19.0	19.0	25.0	25.0
	MOCP	A		28	28	26	26	31	31
	Dimensions	H	In. [mm]	24-13/16 [630]	24-13/16 [630]	37-1/8 [943]	37-1/8 [943]	52-11/16 [1338]	52-11/16 [1338]
		W	In. [mm]	31-13/16 (+7/16) [809 (+62)]	31-13/16 (+7/16) [809 (+62)]	37-13/32 [950]	37-13/32 [950]	41-5/16 [1050]	41-5/16 [1050]
		D	In. [mm]	11-3/16 [300]	11-3/16 [300]	13 (+1-3/16) [330 (+30)]	13 (+1-3/16) [330 (+30)]	13 (+1-3/16) [330 (+30)]	13 (+1-3/16) [330 (+30)]
	Weight	lbs [kg]		92 [41]	99 [44]	151 [68]	151 [68]	211 [96]	211 [96]
	Air Flow Rate (Cooling/Heating)	CFM		1590/—	1590/—	1940/—	1940/—	3880/—	3880/—
Sound Pressure Level	Cooling	dB(A)		44	44	47	47	52	52
	Heating	dB(A)		—	—	—	—	—	—
Piping	Diameter	Gas (O.D.)	In. [mm]	1/2 [12.7]	1/2 [12.7]	5/8 [15.88]	5/8 [15.88]	5/8 [15.88]	5/8 [15.88]
		Liquid (O.D.)	In. [mm]	1/4 [6.35]	1/4 [6.35]	3/8 [9.52]	3/8 [9.52]	3/8 [9.52]	3/8 [9.52]
		Indoor Drain	In. [mm]	1-1/4 [32]	1-1/4 [32]	1-1/4 [32]	1-1/4 [32]	1-1/4 [32]	1-1/4 [32]
	Max. Length	ft [m]		165 [50]	165 [50]	225 [68]	225 [68]	225 [68]	225 [68]
Max. Height	ft [m]		100 [30]	100 [30]	100 [30]	100 [30]	100 [30]	100 [30]	
Electrical	Outdoor-Indoor <sup>5</sup>	V, ph, Hz		208/230, 1, 60	208/230, 1, 60	208/230, 1, 60	208/230, 1, 60	208/230, 1, 60	208/230, 1, 60
	Recommended Breaker Size	A		15	15	25	25	30	30
Refrigerant Type				R410A	R410A	R410A	R410A	R410A	R410A
Guaranteed Temperature Operation Range	Cooling <sup>6</sup>	°F DB [°C DB]		-40 to 115 [-40.0 to 46.0]	-40 to 115 [-40.0 to 46.0]	-40 to 115 [-40.0 to 46.0]	-40 to 115 [-40.0 to 46.0]	-40 to 115 [-40.0 to 46.0]	-40 to 115 [-40.0 to 46.0]
	Heating	°F DB [°C DB]		—	—	—	—	—	—

Notes:  
 AHRI Rated Conditions <sup>1</sup>Cooling (Indoor // Outdoor) <sup>2</sup>°F 80 DB, 67 WB // 95 DB, 75 WB  
 (Rated data is determined at a fixed compressor speed)  
<sup>3</sup>Indoor units receive power from outdoor units through field-supplied interconnected wiring.  
<sup>4</sup>Wind baffles required to operate below 23°F DB in cooling mode. PUY with wind baffle: -40°F - 115°F. Refer to wind baffle documentation for further information.  
 SEACOAST PROTECTION  
 • External Outer Panel: Phosphate coating + Acrylic-Enamel coating  
 • Fan Motor Support: Epoxy resin coating (at edge face)  
 • Separator Assembly, Valve Bed: Epoxy resin coating (at edge face)  
 • "Blue Fin" treatment is an anti-corrosion treatment that is applied to the condenser coil to protect it against airborne contaminants.

# PEAD Model

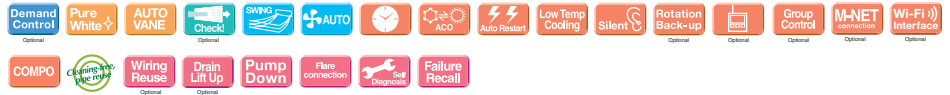

## Heat Pump

Indoor Unit				PEAD-A12AA7	PEAD-A18AA7	PEAD-A24AA7	PEAD-A30AA7	PEAD-A36AA7	PEAD-A42AA7	
Outdoor Unit				PUZ-HA24NHA1	PUZ-HA36NKA	PUZ-A24NHA7(-BS)	PUZ-A30NHA7(-BS)	PUZ-A36NKA7(-BS)	PUZ-A42NKA7(-BS)	
Cooling	Capacity	Rated <sup>1</sup>	BTU/H	24,000	36,000	24,000	30,000	36,000	42,000	
	Capacity Range	Min-Max	BTU/H	10,500–24,000	15,500–36,000	10,000–24,000	9,000–30,000	16,000–36,000	16,000–42,000	
	Power Input	Rated <sup>1</sup>	W	2,120	2,940	2,050	3,000	3,000	3,920	
	Moisture Removal	Pints/h		6.9	5.2	6.9	8.6	8.1	9.0	
	Sensible Heat Factor			0.680	0.840	0.680	0.680	0.750	0.760	
Heating	Capacity at 47°F	Rated <sup>2</sup>	BTU/H	25,000	38,000	26,000	32,000	38,000	45,000	
	Capacity Range	Min-Max	BTU/H	11,800–28,000	17,500–40,000	9,000–28,000	8,800–34,000	18,200–40,000	18,100–48,000	
	Power Input at 47°F	Rated <sup>2</sup>	W	1,810	2,780	1,750	2,490	2,410	3,290	
	Capacity at 17°F	Rated <sup>3</sup>	BTU/H	17,800	24,800	14,800	18,500	20,800	30,600	
	Capacity at 5°F	Max <sup>4</sup>	BTU/H	25,000	38,000	17,200	21,200	24,200	33,700	
	Capacity at -5°F	Max	BTU/H	—	—	—	—	—	—	
Efficiency	SEER			18.0	18.1	19.6	19.1	19.1	16.1	
	EER			11.3	12.2	11.7	10.0	12.0	10.7	
	HSPF			10.4	10.6	10.8	10.8	9.9	10.0	
	COP			4.0	4.0	4.35	3.76	4.62	4.0	
	ENERGY STAR® Certified			No	No	No	No	No	No	
Indoor Unit	Air Flow Rate - Cooling (Quiet-Lo-Med-Hi-SHi)	Dry	CFM	353–424–494	424–512–600	512–635–741	618–742–883	847–1024–1201	1042–1254–1483	
	Air Flow Rate - Cooling (Quiet-Lo-Med-Hi-SHi)	Wet	CFM	318–382–445	382–461–540	461–572–667	556–668–795	762–922–1081	1002–1214–1443	
	Air Flow Rate - Heating (Quiet-Lo-Med-Hi-SHi)	Dry	CFM	353–424–494	424–512–600	512–635–741	618–742–883	847–1024–1201	1042–1254–1483	
	Sound Pressure Level (Quiet-Lo-Med-Hi-SHi)	Cooling	dB(A)	28–30–34	30–33–37	30–33–37	30–34–39	33–38–42	36–40–44	
	Sound Pressure Level (Quiet-Lo-Med-Hi-SHi)	Heating	dB(A)	28–30–34	30–33–37	30–33–37	30–34–39	33–38–42	36–40–44	
	External Static Pressure		In. W.G.	0.14–0.2–0.28–0.4–0.6	0.14–0.2–0.28–0.4–0.6	0.14–0.2–0.28–0.4–0.6	0.14–0.2–0.28–0.4–0.6	0.14–0.2–0.28–0.4–0.6	0.14–0.2–0.28–0.4–0.6	
	Condensate Lift Mechanism	Max Distance	In. [mm]	27-9/16 [700]	27-9/16 [700]	27-9/16 [700]	27-9/16 [700]	27-9/16 [700]	27-9/16 [700]	
	Dimensions	H	In. [mm]	9-7/8 [250]	9-7/8 [250]	9-7/8 [250]	9-7/8 [250]	9-7/8 [250]	9-7/8 [250]	
		W	In. [mm]	35-7/16 [900]	35-7/16 [900]	43-5/16 [1100]	43-5/16 [1100]	55-1/8 [1400]	55-1/8 [1400]	
		D	In. [mm]	28-7/8 [732]	28-7/8 [732]	28-7/8 [732]	28-7/8 [732]	28-7/8 [732]	28-7/8 [732]	
Weight	lbs [kg]		58 [26]	62 [28]	69 [31]	69 [31]	86 [39]	91 [41]		
Outdoor Unit	MCA	A		17.0	26.0	19.0	19.0	25.0	25.0	
	MOCP	A		27	42	26	26	31	31	
	Dimensions	H	In. [mm]	37-1/8 [943]	52-11/16 [1338]	37-1/8 [943]	37-1/8 [943]	52-11/16 [1338]	52-11/16 [1338]	
		W	In. [mm]	37-13/32 [950]	41-5/16 [1050]	37-13/32 [950]	37-13/32 [950]	41-5/16 [1050]	41-5/16 [1050]	
		D	In. [mm]	14-3/16 [360]	14-3/16 [360]	13 (+1-3/16) [330 (+30)]	13 (+1-3/16) [330 (+30)]	13 (+1-3/16) [330 (+30)]	13 (+1-3/16) [330 (+30)]	
	Weight	lbs [kg]		190 [86]	261 [118]	153 [69]	153 [69]	214 [97]	214 [97]	
	Air Flow Rate (Cooling/Heating)	CFM		1940/1940	3880/3880	1940/1940	1940/1940	3880/3880	3880/3880	
	Sound Pressure Level	Cooling	dB(A)		52	52	47	47	52	52
		Heating	dB(A)		53	53	48	48	53	53
	Piping	Diameter	Gas (O.D.)	In. [mm]	5/8 [15.88]	5/8 [15.88]	5/8 [15.88]	5/8 [15.88]	5/8 [15.88]	5/8 [15.88]
Liquid (O.D)			In. [mm]	3/8 [9.52]	3/8 [9.52]	3/8 [9.52]	3/8 [9.52]	3/8 [9.52]	3/8 [9.52]	
Indoor Drain			In. [mm]	1-1/4 [32]	1-1/4 [32]	1-1/4 [32]	1-1/4 [32]	1-1/4 [32]	1-1/4 [32]	
Max. Length		ft [m]		165 [50]	245 [75]	165 [50]	165 [50]	165 [50]	165 [50]	
Max. Height	ft [m]		100 [30]	100 [30]	100 [30]	100 [30]	100 [30]	100 [30]		
Electrical	Outdoor-Indoor <sup>5</sup>	V, ph, Hz		208/230, 1, 60	208/230, 1, 60	208/230, 1, 60	208/230, 1, 60	208/230, 1, 60	208/230, 1, 60	
	Recommended Breaker Size	A		25	35	25	25	30	30	
Refrigerant Type				R410A	R410A	R410A	R410A	R410A	R410A	
Guaranteed Temperature Operation Range	Cooling <sup>6</sup>	°F DB [°C DB]		0 to 115 [-10.0 to 46.0]	0 to 115 [-10.0 to 46.0]	0 to 115 [-18.0 to 46.0]	0 to 115 [-18.0 to 46.0]	0 to 115 [-18.0 to 46.0]	0 to 115 [-18.0 to 46.0]	
	Heating	°F DB [°C DB]		-13 to 75 [-25.0 to 24.0]	-13 to 75 [-25.0 to 24.0]	-4 to 70 [-20.0 to 21.0]	-4 to 70 [-20.0 to 21.0]	-4 to 70 [-20.0 to 21.0]	-4 to 70 [-20.0 to 21.0]	

Notes:  
 AHRI Rated Conditions (Rated data is determined at a fixed compressor speed)  
<sup>1</sup>Cooling (Indoor // Outdoor) °F 80 DB, 67 WB // 95 DB, 75 WB  
<sup>2</sup>Heating at 47°F (Indoor // Outdoor) °F 70 DB, 60 WB // 47 DB, 43 WB  
<sup>3</sup>Heating at 17°F (Indoor // Outdoor) °F 70 DB, 60 WB // 17 DB, 15 WB  
<sup>4</sup>Heating at 5°F (Indoor // Outdoor) °F 70 DB, 60 WB // 5 DB, 4 WB  
<sup>5</sup>Indoor units receive power from outdoor units through field-supplied interconnected wiring.  
<sup>6</sup>Wind baffles required to operate below 23°F DB in cooling mode. PUZ with wind baffle: 0° F - 115° F. Refer to wind baffle documentation for further information.  
 SEACOAST PROTECTION  
 • External Outer Panel: Phosphate coating + Acrylic-Enamel coating  
 • Fan Motor Support: Epoxy resin coating (at edge face)  
 • Separator Assembly, Valve Bed: Epoxy resin coating (at edge face)  
 • "Blue Fin" treatment is an anti-corrosion treatment that is applied to the condenser coil to protect it against airborne contaminants.

# PEAD Model



## Hyper-heating

Indoor Unit			PEAD-A24AA7	PEAD-A30AA7	PEAD-A36AA7	PEAD-A42AA7	
Outdoor Unit			PUZ-HA24NHA1	PUZ-HA30NKA	PUZ-HA36NKA	PUZ-HA42NKA1	
Cooling	Capacity	Rated <sup>1</sup>	BTU/H	24,000	30,000	36,000	42,000
	Capacity Range	Min-Max	BTU/H	10,000–24,000	14,600–30,000	15,600–36,000	17,100–42,000
	Power Input	Rated <sup>1</sup>	W	2,080	2,350	2,850	3,900
	Moisture Removal		Pints/h	6.9	6.5	5.2	4.1
	Sensible Heat Factor			0.680	0.760	0.840	0.890
Heating	Capacity at 47°F	Rated <sup>2</sup>	BTU/H	25,000	32,000	38,000	48,000
	Capacity Range	Min-Max	BTU/H	10,000–28,000	14,800–34,000	17,400–40,000	21,200–54,000
	Power Input at 47°F	Rated <sup>2</sup>	W	1,920	2,740	2,940	3,990
	Capacity at 17°F	Rated <sup>3</sup>	BTU/H	18,000	21,000	25,400	39,000
		Max	BTU/H	25,000	32,000	38,000	48,000
	Capacity at 5°F	Max <sup>4</sup>	BTU/H	25,000	32,000	38,000	48,000
Efficiency	SEER			16.6	18.1	17.1	15.0
	EER			11.5	12.7	12.6	10.7
	HSPF			10.4	9.6	10.4	9.8
	COP			3.8	3.4	3.8	3.5
	ENERGY STAR® Certified			No	Yes	Yes	No
Indoor Unit	Air Flow Rate - Cooling (Quiet-Lo-Med-Hi-SHi)	Dry	CFM	512–635–741	618–742–883	847–1024–1201	1042–1254–1483
	Air Flow Rate - Cooling (Quiet-Lo-Med-Hi-SHi)	Wet	CFM	461–572–667	556–668–795	762–922–1081	1002–1214–1443
	Air Flow Rate - Heating (Quiet-Lo-Med-Hi-SHi)	Dry	CFM	512–635–741	618–742–883	847–1024–1201	1042–1254–1483
	Sound Pressure Level (Quiet-Lo-Med-Hi-SHi)	Cooling	dB(A)	30–33–37	30–34–39	33–38–42	36–40–44
	Sound Pressure Level (Quiet-Lo-Med-Hi-SHi)	Heating	dB(A)	30–33–37	30–34–39	33–38–42	36–40–44
	External Static Pressure		In. W.G.	0.14–0.2–0.28–0.4–0.6	0.14–0.2–0.28–0.4–0.6	0.14–0.2–0.28–0.4–0.6	0.14–0.2–0.28–0.4–0.6
	Condensate Lift Mechanism	Max Distance	In. [mm]	27-9/16 [700]	27-9/16 [700]	27-9/16 [700]	27-9/16 [700]
		H	In. [mm]	9-7/8 [250]	9-7/8 [250]	9-7/8 [250]	9-7/8 [250]
	Dimensions	W	In. [mm]	43-5/16 [1100]	43-5/16 [1100]	55-1/8 [1400]	55-1/8 [1400]
		D	In. [mm]	28-7/8 [732]	28-7/8 [732]	28-7/8 [732]	28-7/8 [732]
Weight		lbs [kg]	69 [31]	69 [31]	86 [39]	91 [41]	
Outdoor Unit	MCA	A		17.0	24.0	26.0	36.0
	MOCP	A		27	40	42	44
	Dimensions	H	In. [mm]	37-1/8 [943]	52-11/16 [1338]	52-11/16 [1338]	52-11/16 [1338]
		W	In. [mm]	37-13/32 [950]	41-5/16 [1050]	41-5/16 [1050]	41-5/16 [1050]
		D	In. [mm]	14-3/16 [360]	14-3/16 [360]	14-3/16 [360]	14-3/16 [360]
	Weight		lbs [kg]	190 [86]	261 [118]	261 [118]	283 [128]
	Air Flow Rate (Cooling/Heating)		CFM	1940/1940	3880/3880	3880/3880	3319/3319
	Sound Pressure Level	Cooling	dB(A)	52	52	52	49
		Heating	dB(A)	53	53	53	51
	Piping	Diameter	Gas (O.D.)	In. [mm]	5/8 [15.88]	5/8 [15.88]	5/8 [15.88]
Liquid (O.D)			In. [mm]	3/8 [9.52]	3/8 [9.52]	3/8 [9.52]	3/8 [9.52]
Indoor Drain			In. [mm]	1-1/4 [32]	1-1/4 [32]	1-1/4 [32]	1-1/4 [32]
Max. Length			ft [m]	165 [50]	245 [75]	245 [75]	245 [75]
Max. Height		ft [m]	100 [30]	100 [30]	100 [30]	100 [30]	
Electrical	Outdoor-Indoor <sup>5</sup>	V, ph, Hz		208/230, 1, 60	208/230, 1, 60	208/230, 1, 60	208/230, 1, 60
	Recommended Breaker Size	A		25	35	35	40
Refrigerant Type				R410A	R410A	R410A	R410A
Guaranteed Temperature Operation Range	Cooling <sup>6</sup>	°F DB [°C DB]		0 to 115 [-10.0 to 46.0]	0 to 115 [-10.0 to 46.0]	0 to 115 [-10.0 to 46.0]	0 to 115 [-10.0 to 46.0]
	Heating	°F DB [°C DB]		-13 to 75 [-25.0 to 24.0]	-13 to 75 [-25.0 to 24.0]	-13 to 75 [-25.0 to 24.0]	-13 to 75 [-25.0 to 24.0]

Notes:  
 AHRI Rated Conditions <sup>1</sup>Cooling (Indoor // Outdoor) °F 80 DB, 67 WB // 95 DB, 75 WB  
 (Rated data is determined at a fixed compressor speed) <sup>2</sup>Heating at 47°F (Indoor // Outdoor) °F 70 DB, 60 WB // 47 DB, 43 WB  
 Conditions <sup>3</sup>Heating at 17°F (Indoor // Outdoor) °F 70 DB, 60 WB // 17 DB, 15 WB  
<sup>4</sup>Heating at 5°F (Indoor // Outdoor) °F 70 DB, 60 WB // 5 DB, 4 WB  
<sup>5</sup>Indoor units receive power from outdoor units through field-supplied interconnected wiring.  
<sup>6</sup>Wind baffles required to operate below 23°F DB in cooling mode. PUZ with wind baffle: 0° F - 115° F.





# PCA Model

Ceiling Suspended



## High Energy Efficiency

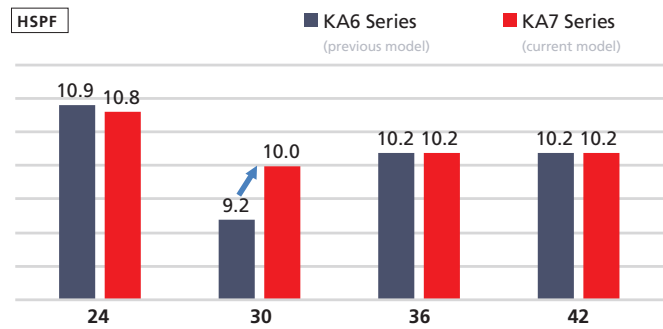
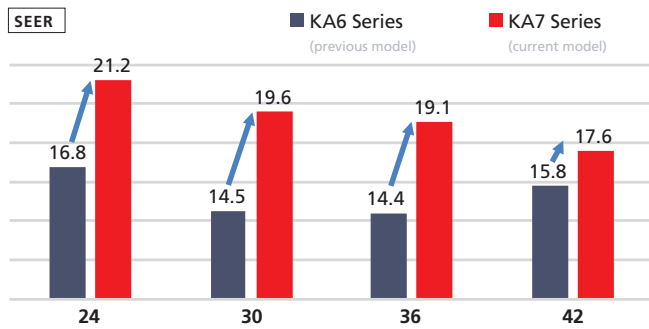

## Optional Drain Pump Available for All Models

The pumping height of the optional drain pump is 23-5/8", expanding flexibility in choosing the indoor unit location.

Drain pump installation possible

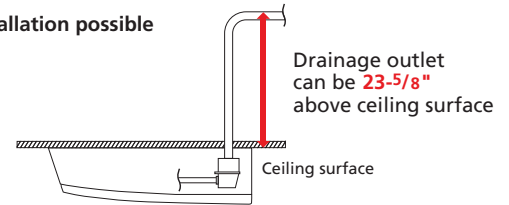

## Equipped with Automatic Air-speed Adjustment

The Automatic Air-speed Adjustment setting changes the speed to match the room environment conditions. The airflow is set to high at the start of the heating or cooling operation, quickly conditioning the space. When the room temperature reaches the set point, the airflow decreases automatically for stable, comfortable heating and cooling operation.

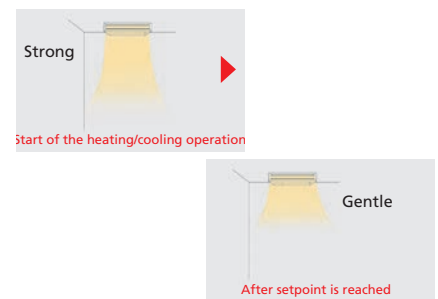

## Equipped with High/Low-Ceiling Modes

High- and Low-ceiling Operation modes match the airflow volume to the room height. This option adjusts the airflow volume and ensures even temperature distribution throughout the room.

Capacity (KBTU/H)	High Ceiling (ft)	Standard Ceiling (ft)	Low Ceiling (ft)
24	11.5	8.9	8.2
30	11.5	8.9	8.2
36	13.8	9.8	8.5
42	13.8	9.8	8.5



# PCA Model



## Model Selection

Indoor Unit



PCA-A24/30/36/42KA7

Outdoor Unit

Cooling Only



PUY-A24/30NHA7



PUY-A36/42NKA7

Heat Pump



PUZ-A24/30NHA7



PUZ-A36/42NKA7

Hyper-heating



PUZ-HA24NHA1



PUZ-HA30/36NKA



PUZ-HA42NKA1

## Remote Controller



\*optional  
PAR-40MAAU



\*optional  
PAC-YT53CRAU-J



\*optional



\*optional  
PAR-CT01MAU-SB



\*optional  
MHK2

# PCA Model



## Cooling Only

Indoor Unit				PCA-A24KA7	PCA-A30KA7	PCA-A36KA7	PCA-A42KA7
Outdoor Unit				PUY-A24NHA7(-B5)	PUY-A30NHA7(-B5)	PUY-A36NKA7(-B5)	PUY-A42NKA7(-B5)
Cooling	Capacity	Rated <sup>1</sup>	BTU/H	24,000	30,000	36,000	42,000
	Capacity Range	Min-Max	BTU/H	10,000–24,000	9,000–30,000	16,000–36,000	16,000–42,000
	Power Input	Rated <sup>1</sup>	W	1,960	3,190	3,270	4,110
	Moisture Removal	Pints/h		5.8	8.3	8.7	11.7
	Sensible Heat Factor			0.730	0.690	0.730	0.690
Heating	Capacity at 47°F	Rated	BTU/H	—	—	—	—
	Capacity Range	Min-Max	BTU/H	—	—	—	—
	Power Input at 47°F	Rated	W	—	—	—	—
	Capacity at 17°F	Rated	BTU/H	—	—	—	—
	Capacity at 5°F	Max	BTU/H	—	—	—	—
	Capacity at -5°F	Max	BTU/H	—	—	—	—
Efficiency	SEER			21.2	19.6	19.1	17.6
	EER			12.2	9.4	11.0	10.2
	HSPF			—	—	—	—
	COP			—	—	—	—
	ENERGY STAR® Certified			No	No	No	No
Indoor Unit	Air Flow Rate - Cooling (Quiet-Lo-Med-Hi-SHi)	Dry	CFM	530–565–600–670	565–600–635–705	775–850–920–990	810–885–955–1025
	Air Flow Rate - Cooling (Quiet-Lo-Med-Hi-SHi)	Wet	CFM	495–530–565–635	530–565–600–670	705–775–850–920	740–810–885–955
	Air Flow Rate - Heating (Quiet-Lo-Med-Hi-SHi)	Dry	CFM	530–565–600–670	565–600–635–705	775–850–920–990	810–885–955–1025
	Sound Pressure Level (Quiet-Lo-Med-Hi-SHi)	Cooling	dB(A)	33–35–37–40	35–37–39–41	37–39–41–43	39–41–43–45
	Sound Pressure Level (Quiet-Lo-Med-Hi-SHi)	Heating	dB(A)	33–35–37–40	35–37–39–41	37–39–41–43	39–41–43–45
	External Static Pressure		In. W.G.	—	—	—	—
	Condensate Lift Mechanism	Max Distance	In. [mm]	—	—	—	—
		H	In. [mm]	9-1/16 [230]	9-1/16 [230]	9-1/16 [230]	9-1/16 [230]
		W	In. [mm]	50-3/8 [1280]	50-3/8 [1280]	63 [1600]	63 [1600]
	Dimensions	D	In. [mm]	26-3/4 [680]	26-3/4 [680]	26-3/4 [680]	26-3/4 [680]
Weight		lbs [kg]	71 [32]	71 [32]	79 [36]	86 [39]	
MCA	A		19.0	19.0	25.0	25.0	
MOCP	A		26	26	31	31	
Outdoor Unit	Dimensions	H	In. [mm]	37-1/8 [943]	37-1/8 [943]	52-11/16 [1338]	52-11/16 [1338]
		W	In. [mm]	37-13/32 [950]	37-13/32 [950]	41-5/16 [1050]	41-5/16 [1050]
		D	In. [mm]	13 (+1-3/16) [330 (+30)]	13 (+1-3/16) [330 (+30)]	13 (+1-3/16) [330 (+30)]	13 (+1-3/16) [330 (+30)]
	Weight	lbs [kg]	151 [68]	151 [68]	211 [96]	211 [96]	
	Air Flow Rate (Cooling/Heating)		CFM	1940/—	1940/—	3880/—	3880/—
Sound Pressure Level	Cooling	dB(A)	47	47	52	52	
	Heating	dB(A)	—	—	—	—	
Piping	Diameter	Gas (O.D.)	In. [mm]	5/8 [15.88]	5/8 [15.88]	5/8 [15.88]	5/8 [15.88]
		Liquid (O.D)	In. [mm]	3/8 [9.52]	3/8 [9.52]	3/8 [9.52]	3/8 [9.52]
		Indoor Drain	In. [mm]	1-1/32 [26]	1-1/32 [26]	1-1/32 [26]	1-1/32 [26]
	Max. Length	ft [m]	225 [68]	225 [68]	225 [68]	225 [68]	
Max. Height	ft [m]	100 [30]	100 [30]	100 [30]	100 [30]		
Electrical	Outdoor-Indoor <sup>5</sup>	V, ph, Hz	208/230, 1, 60	208/230, 1, 60	208/230, 1, 60	208/230, 1, 60	
	Recommended Breaker Size	A	25	25	30	30	
Refrigerant Type			R410A	R410A	R410A	R410A	
Guaranteed Temperature Operation Range	Cooling <sup>6</sup>	°F DB [°C DB]	-40 to 115 [-40 to 46]	-40 to 115 [-40 to 46]	-40 to 115 [-40 to 46]	-40 to 115 [-40 to 46]	
	Heating	°F DB [°C DB]	—	—	—	—	

Notes:  
 AHRI Rated Conditions <sup>1</sup>Cooling (Indoor // Outdoor) °F 80 DB, 67 WB // 95 DB, 75 WB  
 (Rated data is determined at a fixed compressor speed)

- <sup>5</sup>Indoor units receive power from outdoor units through field-supplied interconnected wiring.  
<sup>6</sup>Wind baffles required to operate below 23°F DB in cooling mode. PUY with wind baffle: -40°F - 115°F. Refer to wind baffle documentation for further information.  
 SEACOAST PROTECTION
- External Outer Panel: Phosphate coating + Acrylic-Enamel coating
  - Fan Motor Support: Epoxy resin coating (at edge face)
  - Separator Assembly; Valve Bed: Epoxy resin coating (at edge face)
  - "Blue Fin" treatment is an anti-corrosion treatment that is applied to the condenser coil to protect it against airborne contaminants.

# PCA Model



## Heat Pump

Indoor Unit				PCA-A24KA7	PCA-A30KA7	PCA-A36KA7	PCA-A42KA7
Outdoor Unit				PUZ-A24NHA7(-BS)	PUZ-A30NHA7(-BS)	PUZ-A36NKA7(-BS)	PUZ-A42NKA7(-BS)
Cooling	Capacity	Rated <sup>1</sup>	BTU/H	24,000	30,000	36,000	42,000
	Capacity Range	Min-Max	BTU/H	10,000–24,000	9,000–30,000	16,000–36,000	16,000–42,000
	Power Input	Rated <sup>1</sup>	W	1,960	3,190	3,270	4,110
	Moisture Removal	Pints/h		5.8	8.3	8.7	11.7
	Sensible Heat Factor			0.730	0.690	0.730	0.690
Heating	Capacity at 47°F	Rated <sup>2</sup>	BTU/H	26,000	32,000	38,000	45,000
	Capacity Range	Min-Max	BTU/H	8,800–28,000	8,600–34,000	17,900–40,000	18,100–48,000
	Power Input at 47°F	Rated <sup>2</sup>	W	1,800	2,520	2,410	3,480
	Capacity at 17°F	Rated <sup>3</sup>	BTU/H	15,400	18,800	21,000	31,800
	Capacity at 5°F	Max <sup>4</sup>	BTU/H	17,900	21,600	24,400	35,000
	Capacity at -5°F	Max	BTU/H	14,900	18,000	20,000	30,500
Efficiency	SEER			21.2	19.6	19.1	17.6
	EER			12.2	9.4	11.0	10.2
	HSPF			10.8	10.0	10.2	10.2
	COP			4.23	3.72	4.62	3.78
	ENERGY STAR® Certified			No	No	No	No
Indoor Unit	Air Flow Rate - Cooling (Quiet-Lo-Med-Hi-SHi)	Dry	CFM	530–565–600–670	565–600–635–705	775–850–920–990	810–885–955–1025
	Air Flow Rate - Cooling (Quiet-Lo-Med-Hi-SHi)	Wet	CFM	495–530–565–635	530–565–600–670	705–775–850–920	740–810–885–955
	Air Flow Rate - Heating (Quiet-Lo-Med-Hi-SHi)	Dry	CFM	530–565–600–670	565–600–635–705	775–850–920–990	810–885–955–1025
	Sound Pressure Level (Quiet-Lo-Med-Hi-SHi)	Cooling	dB(A)	33–35–37–40	35–37–39–41	37–39–41–43	39–41–43–45
	Sound Pressure Level (Quiet-Lo-Med-Hi-SHi)	Heating	dB(A)	33–35–37–40	35–37–39–41	37–39–41–43	39–41–43–45
	External Static Pressure		In. W.G.	—	—	—	—
	Condensate Lift Mechanism	Max Distance	In. [mm]	—	—	—	—
	Dimensions	H	In. [mm]	9-1/16 [230]	9-1/16 [230]	9-1/16 [230]	9-1/16 [230]
		W	In. [mm]	50-3/8 [1280]	50-3/8 [1280]	63 [1600]	63 [1600]
		D	In. [mm]	26-3/4 [680]	26-3/4 [680]	26-3/4 [680]	26-3/4 [680]
Weight	lbs [kg]		71 [32]	71 [32]	79 [36]	86 [39]	
Outdoor Unit	MCA	A		19.0	19.0	25.0	25.0
	MOCP	A		26	26	31	31
	Dimensions	H	In. [mm]	37-1/8 [943]	37-1/8 [943]	52-11/16 [1338]	52-11/16 [1338]
		W	In. [mm]	37-13/32 [950]	37-13/32 [950]	41-5/16 [1050]	41-5/16 [1050]
		D	In. [mm]	13 (+1-3/16) [330 (+30)]	13 (+1-3/16) [330 (+30)]	13 (+1-3/16) [330 (+30)]	13 (+1-3/16) [330 (+30)]
	Weight	lbs [kg]		153 [69]	153 [69]	214 [97]	214 [97]
	Air Flow Rate (Cooling/Heating)		CFM	1940/1940	1940/1940	3880/3880	3880/3880
	Sound Pressure Level	Cooling	dB(A)	47	47	52	52
		Heating	dB(A)	48	48	53	53
	Piping	Diameter	Gas (O.D.)	In. [mm]	5/8 [15.88]	5/8 [15.88]	5/8 [15.88]
Liquid (O.D)			In. [mm]	3/8 [9.52]	3/8 [9.52]	3/8 [9.52]	3/8 [9.52]
Indoor Drain			In. [mm]	1-1/32 [26]	1-1/32 [26]	1-1/32 [26]	1-1/32 [26]
Max. Length		ft [m]	165 [50]	165 [50]	165 [50]	165 [50]	
Max. Height		ft [m]	100 [30]	100 [30]	100 [30]	100 [30]	
Electrical	Outdoor-Indoor <sup>5</sup>	V, ph, Hz		208/230, 1, 60	208/230, 1, 60	208/230, 1, 60	208/230, 1, 60
	Recommended Breaker Size	A		25	25	30	30
Refrigerant Type				R410A	R410A	R410A	R410A
Guaranteed Temperature Operation Range	Cooling <sup>6</sup>	°F DB [°C DB]		0 to 115 [-18 to 46]	0 to 115 [-18 to 46]	0 to 115 [-18 to 46]	0 to 115 [-18 to 46]
	Heating	°F DB [°C DB]		-4 to 70 [-20 to 21]	-4 to 70 [-20 to 21]	-4 to 70 [-20 to 21]	-4 to 70 [-20 to 21]

Notes:  
 AHRI Rated Conditions (Rated data is determined at a fixed compressor speed)  
 Conditions  
<sup>1</sup>Cooling (Indoor // Outdoor) °F 80 DB, 67 WB // 95 DB, 75 WB  
<sup>2</sup>Heating at 47°F (Indoor // Outdoor) °F 70 DB, 60 WB // 47 DB, 43 WB  
<sup>3</sup>Heating at 17°F (Indoor // Outdoor) °F 70 DB, 60 WB // 17 DB, 15 WB  
<sup>4</sup>Heating at 5°F (Indoor // Outdoor) °F 70 DB, 60 WB // 5 DB, 4 WB  
<sup>5</sup>Indoor units receive power from outdoor units through field-supplied interconnected wiring.  
<sup>6</sup>Wind baffles required to operate below 23°F DB in cooling mode. PUZ with wind baffle: 0° F - 115° F. Refer to wind baffle documentation for further information.  
 SEACOAST PROTECTION  
 • External Outer Panel: Phosphate coating + Acrylic-Enamel coating  
 • Fan Motor Support: Epoxy resin coating (at edge face)  
 • Separator Assembly, Valve Bed: Epoxy resin coating (at edge face)  
 • "Blue Fin" treatment is an anti-corrosion treatment that is applied to the condenser coil to protect it against airborne contaminants.

# PCA Model



## Hyper-heating

Indoor Unit			PCA-A24KA7	PCA-A30KA7	PCA-A36KA7	PCA-A42KA7	
Outdoor Unit			PUZ-HA24NHA1	PUZ-HA30NKA	PUZ-HA36NKA	PUZ-HA42NKA1	
Cooling	Capacity	Rated <sup>1</sup>	BTU/H	23,000	30,000	34,000	42,000
	Capacity Range	Min-Max	BTU/H	10,000–24,000	14,300–30,000	14,900–34,000	16,600–42,000
	Power Input	Rated <sup>1</sup>	W	1,840	2,380	2,700	4,050
	Moisture Removal		Pints/h	5.6	8.3	7.9	10.6
	Sensible Heat Factor			0.730	0.690	0.740	0.720
Heating	Capacity at 47°F	Rated <sup>2</sup>	BTU/H	26,000	32,000	38,000	48,000
	Capacity Range	Min-Max	BTU/H	10,000–28,000	14,400–35,000	17,400–40,000	24,000–54,000
	Power Input at 47°F	Rated <sup>2</sup>	W	2,050	2,930	3,360	4,760
	Capacity at 17°F	Rated <sup>3</sup>	BTU/H	17,700	22,200	25,400	38,500
		Max	BTU/H	26,000	32,000	38,000	48,000
	Capacity at 5°F	Max <sup>4</sup>	BTU/H	26,000	32,000	38,000	48,000
Efficiency	SEER			18.5	17.9	18.0	15.5
	EER			12.5	12.6	12.5	10.3
	HSPF			10.3	9.4	10.3	10.0
	COP			3.71	3.2	3.31	2.95
	ENERGY STAR® Certified			Yes	Yes	Yes	No
Indoor Unit	Air Flow Rate - Cooling (Quiet-Lo-Med-Hi-SHi)	Dry	CFM	530–565–600–670	565–600–635–705	775–850–920–990	810–885–955–1025
	Air Flow Rate - Cooling (Quiet-Lo-Med-Hi-SHi)	Wet	CFM	495–530–565–635	530–565–600–670	705–775–850–920	740–810–885–955
	Air Flow Rate - Heating (Quiet-Lo-Med-Hi-SHi)	Dry	CFM	530–565–600–670	565–600–635–705	775–850–920–990	810–885–955–1025
	Sound Pressure Level (Quiet-Lo-Med-Hi-SHi)	Cooling	dB(A)	33–35–37–40	35–37–39–41	37–39–41–43	39–41–43–45
	Sound Pressure Level (Quiet-Lo-Med-Hi-SHi)	Heating	dB(A)	33–35–37–40	35–37–39–41	37–39–41–43	39–41–43–45
	External Static Pressure		In. W.G.	—	—	—	—
	Condensate Lift Mechanism	Max Distance	In. [mm]	—	—	—	—
	Dimensions	H	In. [mm]	9-1/16 [230]	9-1/16 [230]	9-1/16 [230]	9-1/16 [230]
		W	In. [mm]	50-3/8 [1280]	50-3/8 [1280]	63 [1600]	63 [1600]
		D	In. [mm]	26-3/4 [680]	26-3/4 [680]	26-3/4 [680]	26-3/4 [680]
Weight		lbs [kg]	71 [32]	71 [32]	79 [36]	86 [39]	
Outdoor Unit	MCA	A		17.0	24.0	26.0	36.0
	MOCP	A		27	40	42	44
	Dimensions	H	In. [mm]	37-1/8 [943]	52-11/16 [1338]	52-11/16 [1338]	52-11/16 [1338]
		W	In. [mm]	37-13/32 [950]	41-5/16 [1050]	41-5/16 [1050]	41-5/16 [1050]
		D	In. [mm]	14-3/16 [360]	14-3/16 [360]	14-3/16 [360]	14-3/16 [360]
	Weight		lbs [kg]	190 [86]	261 [118]	261 [118]	283 [128]
	Air Flow Rate (Cooling/Heating)		CFM	1940/1940	3880/3880	3880/3880	3319/3319
	Sound Pressure Level	Cooling	dB(A)	52	52	52	49
		Heating	dB(A)	53	53	53	51
	Piping	Diameter	Gas (O.D.)	In. [mm]	5/8 [15.88]	5/8 [15.88]	5/8 [15.88]
Liquid (O.D.)			In. [mm]	3/8 [9.52]	3/8 [9.52]	3/8 [9.52]	3/8 [9.52]
Indoor Drain			In. [mm]	1-1/32 [26]	1-1/32 [26]	1-1/32 [26]	1-1/32 [26]
Max. Length		ft [m]	165 [50]	245 [75]	245 [75]	245 [75]	
Max. Height		ft [m]	100 [30]	100 [30]	100 [30]	100 [30]	
Electrical	Outdoor-Indoor <sup>5</sup>	V, ph, Hz		208/230, 1, 60	208/230, 1, 60	208/230, 1, 60	208/230, 1, 60
	Recommended Breaker Size	A		25	35	35	40
Refrigerant Type				R410A	R410A	R410A	R410A
Guaranteed Temperature Operation Range	Cooling <sup>6</sup>	°F DB [°C DB]		23 to 115	23 to 115	23 to 115	23 to 115
	Heating	°F DB [°C DB]		-13 to 70	-13 to 70	-13 to 70	-13 to 70

Notes:  
 AHRI Rated Conditions  
 (Rated data is determined at a fixed compressor speed)  
 Conditions  
<sup>1</sup>Cooling (Indoor // Outdoor) °F 80 DB, 67 WB // 95 DB, 75 WB  
<sup>2</sup>Heating at 47°F (Indoor // Outdoor) °F 70 DB, 60 WB // 47 DB, 43 WB  
<sup>3</sup>Heating at 17°F (Indoor // Outdoor) °F 70 DB, 60 WB // 17 DB, 15 WB  
<sup>4</sup>Heating at 5°F (Indoor // Outdoor) °F 70 DB, 60 WB // 5 DB, 4 WB  
<sup>5</sup>Indoor units receive power from outdoor units through field-supplied interconnected wiring.  
<sup>6</sup>Wind baffles required to operate below 23°F DB in cooling mode. PUZ with wind baffle: 0° F - 115° F.





# Multi-Zone M-Series Models

M-Series multi-zone outdoor units operate 2 to 8 indoor units on the same system.

# Multi-Zone Model Line Up

Choose from six types of indoor units and thirteen outdoor units that can run up to eight indoor units each.

## Step 1: Select Your Indoor Unit to be Installed in Each Room

Choose from Wall Mounted, Floor Mounted, Multi-Position Air Handler, Ceiling Cassette, Ceiling Suspended or Horizontal Ducted.



## Step 2: Select Your Outdoor Unit

Select the best outdoor unit based on the number of indoor units and overall system capacity required.

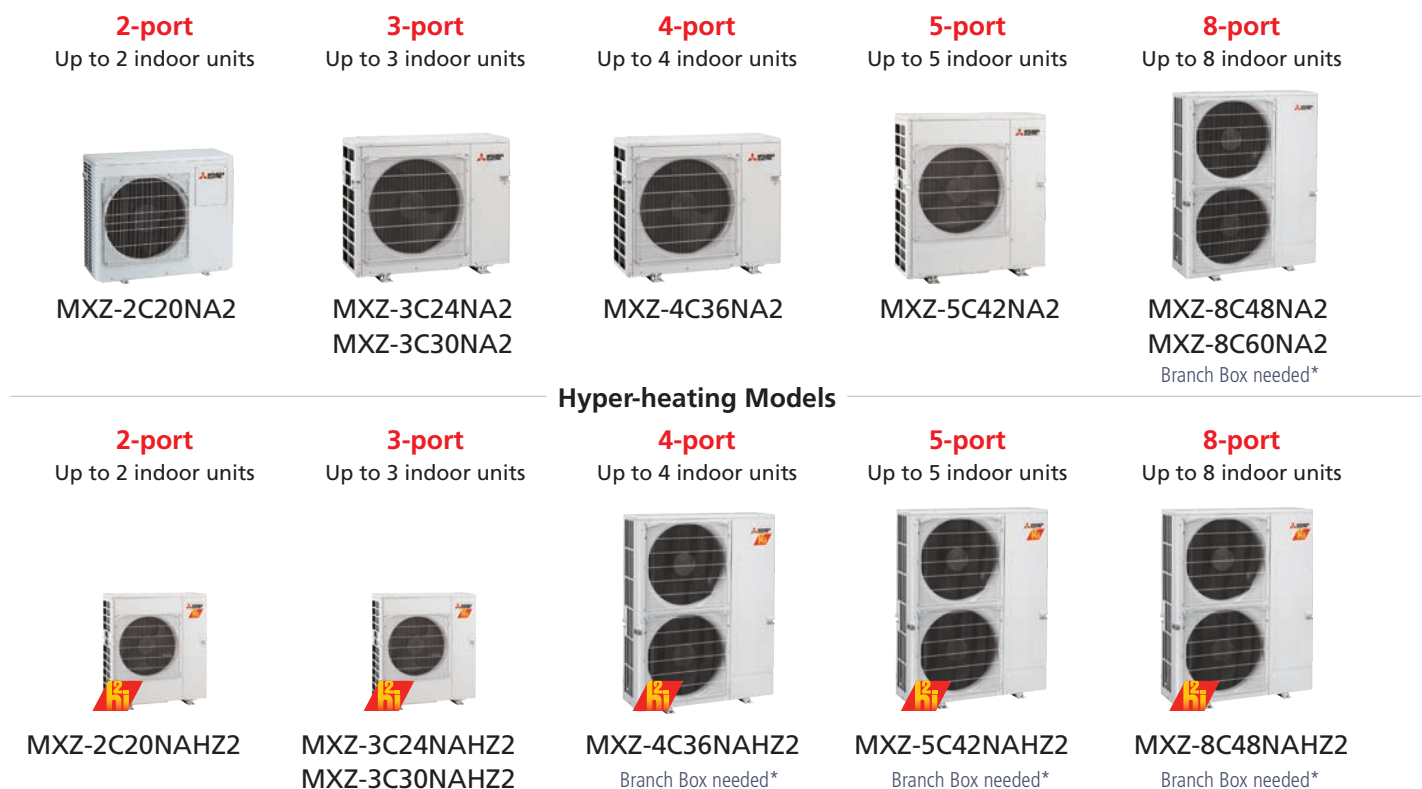

## Step 3: Check System Compatibility

Possible combinations depends on the outdoor unit chosen. Please check the following points.

**Check Indoor Units** Refer to the Indoor Unit Compatibility Table to check if the indoor units selected can be used with the outdoor unit selected. (Indoor units not listed in the table cannot be used.)

**Check Branch Box** Refer to the Indoor Unit Compatibility Table for units that require a Branch Box.

If the desired combination cannot be found, please change either the indoor or outdoor unit to match one of the combinations shown in the tables.

# MXZ Models

Multi-zone Heat Pump Outdoor Unit



**2-port**  
MXZ-2C20NA2



**3-port and 4-port**  
MXZ-3C24NA2  
MXZ-3C30NA2  
MXZ-4C36NA2



**5-port**  
MXZ-5C42NA2



**8-port**  
MXZ-8C48NA2  
MXZ-8C60NA2  
8 Port Branch Box required

## Example System

Smaller MXZ-C 2, 3, 4 and 5 ports  
(example of MXZ-5C42NA2 system)

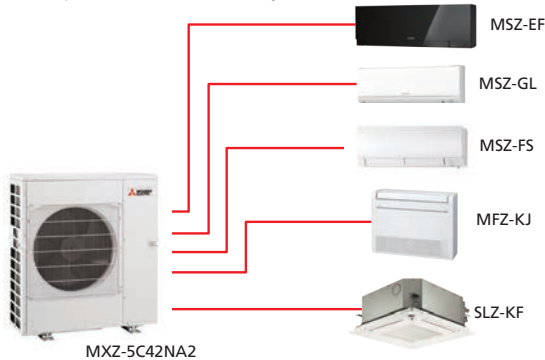

MXZ-8C48NA2  
MXZ-8C60NA2

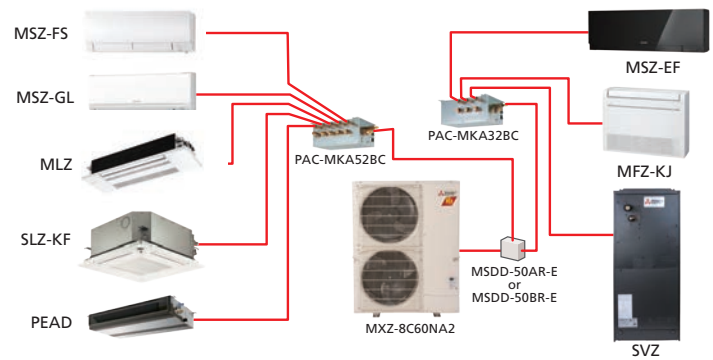

## Handle Up to 8 Rooms with a Single Outdoor Unit

The MXZ-C Model offers a seven-system line-up to choose from, ranging between 20,000 and 60,000 BTU/H. All of them are compatible with specific M- and P-Series indoor units. A single outdoor unit can handle a wide range of building layouts.

## Optional Drain for All Models

With MXZ-C Model one outdoor unit can cool and heat up to eight rooms. They can be installed neatly in sites with limited space such as condominium balconies.

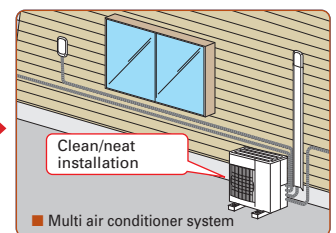
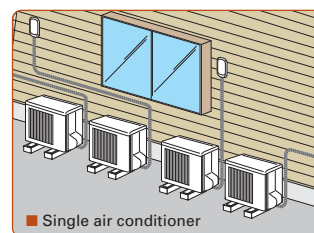



# MXZ-C Model



## INVERTER-driven Multi-zone Heat Pump

Type				Up to 2 indoor units	Up to 3 indoor units		Up to 4 indoor units	Up to 5 indoor units	Up to 8 indoor units	
Outdoor Unit				MXZ-2C20NA2	MXZ-3C24NA2	MXZ-3C30NA2	MXZ-4C36NA2	MXZ-5C42NA2	MXZ-8C48NA2	MXZ-8C60NA2
Branch Box Required				No	No	No	No	No	Yes	Yes
Power Supply	Source			R410A	R410A	R410A	R410A	R410A	R410A	R410A
	Outdoor (Phase, Hz, V)			1-phase, 60Hz, 208/230V	1-phase, 60Hz, 208/230V	1-phase, 60Hz, 208/230V	1-phase, 60Hz, 208/230V	1-phase, 60Hz, 208/230V	1-phase, 60Hz, 208/230V	1-phase, 60Hz, 208/230V
Cooling	Capacity	Rated *1	BTU/H	18,000	22,000	28,400	35,400	40,500	48,000	60,000
	SEER			Refer to page 148						
Heating	Capacity	Rated *1	BTU/H	22,000	25,000	28,600	36,000	45,000	54,000	66,000
		Max at 17F *2	BTU/H	12,500	19,600	21,000	26,600	30,500	36,600	65,000
		Max at 5F *3	BTU/H	11,100	18,200	18,200	24,000	26,000	32,400	57,000
	HSPF			Refer to page 148						
Outdoor Unit	MCA		A	17.2	22.1	22.1	22.1	32.5	35.0	46.0
	Recommended Fuse/Breaker Size		A	20	25	25	25	40	40	50
	Dimensions	W	In. [mm]	33-1/16 [840]	37-13/32 [950]	37-13/32 [950]	37-13/32 [950]	37-13/32 [950]	41-11/32 [1,050]	41-11/32 [1,050]
		D	In. [mm]	13 [330]	13 [330]	13 [330]	13 [330]	13 [330]	13+1 [330+25]	13+1 [330+25]
		H	In. [mm]	27-15/16 [710]	31-11/32 [796]	31-11/32 [796]	31-11/32 [796]	41-17/64 [1,048]	52-11/16 [1,338]	52-11/16 [1,338]
	Weight		lbs [kg]	126 [57]	137 [62]	137 [62]	139 [63]	189 [86]	271 [123]	302 [137]
	Air volume (Cooling/Heating)		CFM	1,342/1,458	2,287/2,382	2,287/2,382	2,287/2,382	2,118/2,542	3,885	4,879
Sound Level	Cooling	dB [A]	50	51	52	54	56	51	58	
	Heating	dB [A]	54	55	56	56	58	54	59	
Piping	Diameter	Gas	In. [mm]	3/8 [9.52]	A: 1/2 [12.7] B,C: 3/8 [9.52]	A: 1/2 [12.7] B,C: 3/8 [9.52]	A: 1/2 [12.7] B,C,D: 3/8 [9.52]	A: 1/2 [12.7] B,C,D,E: 3/8 [9.52]	5/8 [15.88]	3/4 [19.05]
		Liquid	In. [mm]	1/4 [6.35]	1/4 [6.35]	1/4 [6.35]	1/4 [6.35]	1/4 [6.35]	3/8 [9.52]	3/8 [9.52]
	Max. Length		ft [m]	164 [50]	230 [70]	230 [70]	230 [70]	262 [80]	492 [150]	492 [150]
Height		ft [m]	49 [15]	49 [15]	49 [15]	49 [15]	49 [15]	164 [50]	164 [50]	
Guaranteed Operation Range		Cooling	F [C]	14 ~ 115°FDB [-10 ~ 46°CDB]	14 ~ 115°FDB [-10 ~ 46°CDB]	14 ~ 115°FDB [-10 ~ 46°CDB]	14 ~ 115°FDB [-10 ~ 46°CDB]	14 ~ 115°FDB [-10 ~ 46°CDB]	23 ~ 115°FDB [-5 ~ 46°CDB] *5	23 ~ 115°FDB [-5 ~ 46°CDB] *5
		Heating	F [C]	5 ~ 75°FDB [-15 ~ 24°CDB]	5 ~ 75°FDB [-15 ~ 24°CDB]	5 ~ 75°FDB [-15 ~ 24°CDB]	5 ~ 75°FDB [-15 ~ 24°CDB]	5 ~ 75°FDB [-15 ~ 24°CDB]	-4 ~ 70°FDB [-20 ~ 21°CDB]	-4 ~ 70°FDB [-20 ~ 21°CDB]

NOTE:

Test conditions are based on AHRI 210/240.

\*1 Rating Conditions (Cooling) - Indoor: 80° FDB, 67° FWB, Outdoor: 95° FDB, (75° FWB)

(Heating) - Indoor: 70° FDB, 60° FWB, Outdoor: 47° FDB, 43° FWB

\*2 Rating Conditions (Heating) - Indoor: 70° FDB, 60° FWB, Outdoor: 17° FDB, 15° FWB

\*3 Rating Conditions (Heating) - Indoor: 70° FDB, 60° FWB, Outdoor: 5° FDB, 5° FWB

\*5 °F DB - 115°F DB when optional wind baffles are installed

## Branch Box

Type				Branch Box	
Model Name				PAC-MKA32BC	PAC-MKA52BC
Connectible Number of Indoor Units				Maximum 3	Maximum 5
Power Supply				1-phase, 60Hz, 208/230V	1-phase, 60Hz, 208/230V
Input		kW		0.003	0.003
Running Current		A		0.05	0.05
Dimensions	W	In. [mm]	17-23/32 [450]	17-23/32 [450]	
	D	In. [mm]	11-1/32 [280]	11-1/32 [280]	
	H	In. [mm]	6-11/16 [170]	6-11/16 [170]	
Weight		lbs [kg]		15 [6.7]	16 [7.4]
Piping Connection (Flare)	Branch (indoor side)*	Gas	In. [mm]	3/8 [9.52] × 3	3/8 [9.52] × 4 1/2 [12.7] × 1
		Liquid	In. [mm]	1/4 [6.35] × 3	1/4 [6.35] × 5
	Main (outdoor side)*	Gas	In. [mm]	5/8 [15.88]	5/8 [15.88]
		Liquid	In. [mm]	3/8 [9.52]	3/8 [9.52]

\*The piping connection size differs according to the type and capacity of indoor units. Match the piping connection size for indoor and branch box. If the piping connection size of branch box does not match the piping connection size of indoor units, use optional different-diameter (deformed) joints to the branch box side. (Connect deformed joint directly to the branch box side.)



## MXZ-NAHZ Model **Hi**

### Hyper-Heating INVERTER® Performance

Standard rated heating capacity is maintained even when the outside-air temperature drops to 5° F. Maintains high capacity output even when outside-air temperature is low.

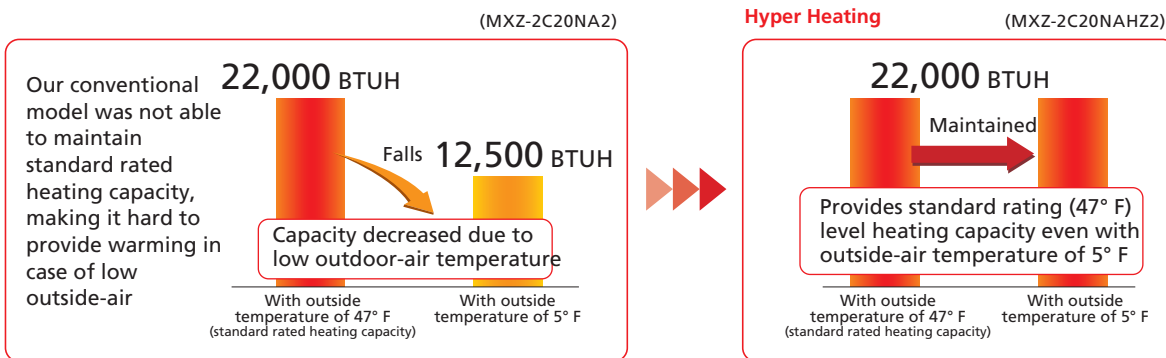

### Can Operate At Outside-Air Temperature Of -13° F

Incorporated key parts resistant to cold of up to -13° F after rigorous selection. Printed circuit board is coated on both sides to protect it in harsh environments.

### Base Pan Heater Built-In

Drain water **freezes** after operation in extreme low temperatures

**Hyper heating with base heater installed as standard prevents ice build up**



Without base heater

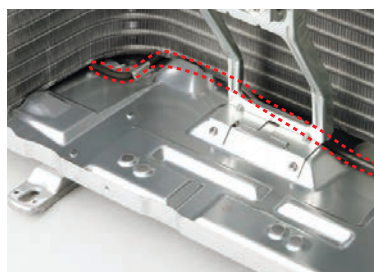

With base heater

# Continuous Heating For Long Periods

Extremely cold outside

Hyper Heating



MXZ-C-NAHZ Model

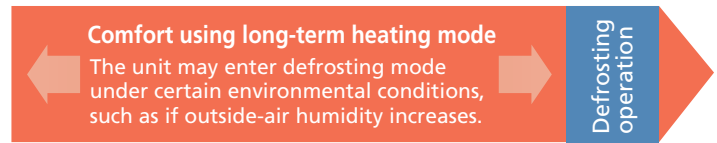

MXZ-C-NA Model



## MXZ-NAHZ Hyper-Heating INVERTER® Multi-zone Outdoor Units

Type			Up to 2 indoor units	Up to 3 indoor units	Up to 4 indoor units	Up to 5 indoor units	Up to 8 indoor units		
Power Supply	Outdoor Unit		MXZ-2C20NAHZ2	MXZ-3C24NAHZ2	MXZ-3C30NAHZ2	MXZ-4C36NAHZ2	MXZ-5C42NAHZ2	MXZ-8C48NAHZ2	
	Branch Box Required		No	No	No	Yes	Yes	Yes	
	Source		R410A	R410A	R410A	R410A	R410A	R410A	
	Outdoor (Phase, Hz, V)		1-phase, 60Hz, 208/230V	1-phase, 60Hz, 208/230V	1-phase, 60Hz, 208/230V	1-phase, 60Hz, 208/230V	1-phase, 60Hz, 208/230V	1-phase, 60Hz, 208/230V	
Cooling	Recommended Breaker Size		40	40	40	50	50	50	
	Capacity	Rated *1 BTU/H	18,000	22,000	28,400	36,000	42,000	48,000	
Heating	SEER		Refer to page 148						
	EER		Refer to page 148						
	Capacity	Rated *1	BTU/H	22,000	25,000	28,600	45,000	48,000	54,000
		Max at 17F *2	BTU/H	22,000	25,000	28,600	45,000	48,000	54,000
		Max at 5F *3	BTU/H	22,000	25,000	28,600	45,000	48,000	54,000
HSPF		Refer to page 148							
Outdoor Unit	MCA		A	29.5	30.5	30.5	42	42	42
	Recommended breaker/fuse size		A	40	40	50	45	45	45
	Dimensions	W	In. [mm]	37-13/32 [950]	37-13/32 [950]	41-11/32 [1,050]	41-11/32 [1,050]	41-11/32 [1,050]	41-11/32 [1,050]
		D	In. [mm]	13 [330]	13 [330]	13 [330]	13+1 [330+25]	13+1 [330+25]	13+1 [330+25]
H		In. [mm]	41-17/64 [1,048]	41-17/64 [1,048]	41-17/64 [1,048]	52-11/16 [1,338]	52-11/16 [1,338]	52-11/16 [1,338]	
Weight		lbs [kg]	187 [85]	189 [86]	189 [86]	278 [126]	278 [126]	278 [126]	
Air volume (Cooling/Heating)		CFM	2,118/2,542	2,188/2,542	2,224/2,542	3,885	3,885	3,885	
Sound Level	Cooling	dB [A]	54	54	54	49	50	51	
	Heating	dB [A]	58	58	58	53	54	54	
Piping	Diameter	Gas	In. [mm]	3/8 [9.52]	A: 1/2 [12.7] B,C: 3/8 [9.52]	A: 1/2 [12.7] B,C: 3/8 [9.52]	5/8 [15.88]	5/8 [15.88]	5/8 [15.88]
		Liquid	In. [mm]	1/4 (6.35)	1/4 (6.35)	1/4 (6.35)	3/8 [9.52]	3/8 [9.52]	3/8 [9.52]
	Max. Length		ft [m]	164 [50]	230 [70]	230 [70]	492 [150]	492 [150]	492 [150]
	Height		ft [m]	49 [15]	49 [15]	49 [15]	164 [50]	164 [50]	164 [50]
Guaranteed Operation Range	Cooling	F [C]	14 ~ 115°FDB [-10 ~ 46°CDB]	14 ~ 115°FDB [-10 ~ 46°CDB]	14 ~ 115°FDB [-10 ~ 46°CDB]	23 ~ 115°FDB [-5 ~ 46°CDB] *5	23 ~ 115°FDB [-5 ~ 46°CDB] *5	23 ~ 115°FDB [-5 ~ 46°CDB] *5	
	Heating	F [C]	-13 ~ 75°FDB [-25 ~ 24°CDB]	-13 ~ 75°FDB [-25 ~ 24°CDB]	-13 ~ 75°FDB [-25 ~ 24°CDB]	-13 ~ 70°FDB [-25 ~ 21°CDB]	-13 ~ 70°FDB [-25 ~ 21°CDB]	-13 ~ 70°FDB [-25 ~ 21°CDB]	

NOTE:

Test conditions are based on AHRI 210/240.

\*1 Rating Conditions (Cooling) - Indoor: 80° FDB, 67° FWB, Outdoor: 95° FDB, (75° FWB)  
(Heating) - Indoor: 70° FDB, 60° FWB, Outdoor: 47° FDB, 43° FWB

\*2 Rating Conditions (Heating) - Indoor: 70° FDB, 60° FWB, Outdoor: 17° FDB, 15° FWB

\*3 Rating Conditions (Heating) - Indoor: 70° FDB, 60° FWB, Outdoor: 5° FDB, 5° FWB

\*5 °F DB - 115°F DB when optional wind baffles are installed

# Indoor Unit Compatibility Table

## MXZ Model \*1

Possible combinations of outdoor units and indoor units are shown below.

		Outdoor Unit	MXZ-2C20NA2	MXZ-3C24NA2	MXZ-3C30NA2	MXZ-4C36NA2	MXZ-5C42NA2	MXZ-8C48NA2	MXZ-8C60NA2
M-Series	Wall Mounted	Indoor Unit							
		MSZ-FH06NA	•	•	•	•	•	•	•
		MSZ-FH09NA	•	•	•	•	•	•	•
		MSZ-FH12NA	•	•	•	•	•	•	•
		MSZ-FH15NA	•	•	•	•	•	•	•
		MSZ-FH18NA2		•	•	•	•	•	•
		MSZ-GL06NA	•	•	•	•	•	•	•
		MSZ-GL09NA	•	•	•	•	•	•	•
		MSZ-GL12NA	•	•	•	•	•	•	•
		MSZ-GL15NA	•	•	•	•	•	•	•
		MSZ-GL18NA		•	•	•	•	•	•
		MSZ-GL24NA			•	•	•	•	•
		MSZ-EF09NAW(S)(B)	•	•	•	•	•	•	•
		MSZ-EF12NAW(S)(B)	•	•	•	•	•	•	•
	MSZ-EF15NAW(S)(B)	•	•	•	•	•	•	•	
	MSZ-EF18NAW(S)(B)		•	•	•	•	•	•	
	Floor Standing	MFZ-KJ09NA	•	•	•	•	•	•	•
		MFZ-KJ12NA	•	•	•	•	•	•	•
		MFZ-KJ15NA	•	•	•	•	•	•	•
		MFZ-KJ18NA		•	•	•	•	•	•
	EZ FIT® Recessed Ceiling Cassette	MLZ-KP09NA	•	•	•	•	•	•	•
		MLZ-KP12NA	•	•	•	•	•	•	•
		MLZ-KP18NA	•	•	•	•	•	•	•
	Multi-position Air Handler	SVZ-KP12NA	•*2	•*2	•*2	•*2	•*2	•*3,4	•*3,4
		SVZ-KP18NA		•*2	•*2	•*2	•*2	•*3,4	•*3,4
		SVZ-KP24NA			•*2	•*2	•*2	•*3,4	•*3,4
		SVZ-KP30NA						•*3,4	•*3,4
		SVZ-KP36NA						•*3,4	•*3,4
	4-way Cassette	SLZ-KF09NA	•	•	•	•	•	•	•
		SLZ-KF12NA	•	•	•	•	•	•	•
		SLZ-KF15NA		•	•	•	•	•	•
	Horizontal-ducted	SEZ-KD09NA4	•	•	•	•	•	•*6	•*7
SEZ-KD12NA4		•	•	•	•	•	•*6	•*7	
SEZ-KD15NA4		•	•	•	•	•	•*6	•*7	
SEZ-KD18NA4			•	•	•	•	•*6	•*7	
P-Series	4-way Cassette	PLA-A12EA7						•*5	•*5
		PLA-A18EA7		•	•	•	•	•*5	•*5
		PLA-A24EA7						•*5	•*5
		PLA-A30EA7						•*5	•*5
		PLA-A36EA7						•*5	•*5
		PLA-A42EA7							
	Ceiling Suspended	PCA-A24KA7			•	•	•		
		PCA-A30KA7							
		PCA-A36KA7							
		PCA-A42KA7							
	Horizontal-ducted	PEAD-A12AA7	•*3	•*3	•*3	•*3	•*3	•*6	•*7
		PEAD-A18AA7		•	•*3	•*3	•*3	•*6	•*7
		PEAD-A24AA7			•	•	•*3	•*6	•*7
		PEAD-A30AA7						•*6	•*7
		PEAD-A36AA7						•*6	•*7
PEAD-A42AA7									
Branch Box	3 port	PAC-MKA32BC						•	•
	5 port	PAC-MKA52BC						•	•

Information is current as of this printing. Minimum installed capacity cannot be less than 12,000 BTU/H. A minimum of two indoor units must be connected to all MXZ-C outdoor units.

\*2 Only one SVZ Model can be connected.

\*3 Maximum of two units can be connected unless the SPTB1 is utilized to power the indoor unit.

\*4 Single unit can be connected.

\*5 When the system includes even 1 unit of PLA-A-EA7, the number of the maximum connectable indoor units is decreased as follows: 3 for MXZ-4C36NAHZ, 4 for MXZ-5C42NAHZ, and 6 for MXZ-8C48NA(HZ) and MXZ-8C60NA.

\*6 Maximum of 3 horizontal ducted indoor units (PEAD or SEZ) can be connected.

\*7 Maximum of 2 horizontal ducted indoor units (PEAD or SEZ) can be connected.

For more information, please refer to the Service Manual, Application Note 1039 and the full compatibility chart on MyLinkDrive.com.

# MXZ-NAHZ Model \*1

Possible combinations of outdoor units and indoor units are shown below.

		Outdoor Unit	MXZ-2C20NAHZ2	MXZ-3C24NAHZ2	MXZ-3C30NAHZ2	MXZ-4C36NAHZ2	MXZ-5C42NAHZ2	MXZ-8C48NAHZ2
M-Series	Wall Mounted	<b>Indoor Unit</b>						
		MSZ-FH06NA	•	•	•	•	•	•
		MSZ-FH09NA	•	•	•	•	•	•
		MSZ-FH12NA	•	•	•	•	•	•
		MSZ-FH15NA	•	•	•	•	•	•
		MSZ-FH18NA2		•	•	•	•	•
		MSZ-GL06NA	•	•	•	•	•	•
		MSZ-GL09NA	•	•	•	•	•	•
		MSZ-GL12NA	•	•	•	•	•	•
		MSZ-GL15NA	•	•	•	•	•	•
		MSZ-GL18NA		•	•	•	•	•
		MSZ-GL24NA			•	•	•	•
		MSZ-EF09NAW(S)(B)	•	•	•	•	•	•
		MSZ-EF12NAW(S)(B)	•	•	•	•	•	•
	MSZ-EF15NAW(S)(B)	•	•	•	•	•	•	
	MSZ-EF18NAW(S)(B)		•	•	•	•	•	
	Floor Standing	MFZ-KJ09NA	•	•	•	•	•	•
		MFZ-KJ12NA	•	•	•	•	•	•
		MFZ-KJ15NA	•	•	•	•	•	•
		MFZ-KJ18NA		•	•	•	•	•
	EZ FIT® Recessed Ceiling Cassette	MLZ-KP09NA	•	•	•	•	•	•
		MLZ-KP12NA	•	•	•	•	•	•
		MLZ-KP18NA	•	•	•	•	•	•
	Multi-position Air Handler	SVZ-KP12NA	•*2	•*2	•*2	•*3, 4	•*3, 4	•*3, 4
		SVZ-KP18NA		•*2	•*2	•*3, 4	•*3, 4	•*3, 4
		SVZ-KP24NA			•*2	•*3, 4	•*3, 4	•*3, 4
		SVZ-KP30NA				•*3, 4	•*3, 4	•*3, 4
		SVZ-KP36NA				•*3, 4	•*3, 4	•*3, 4
	4-way Cassette	SLZ-KF09NA	•	•	•	•	•	•
		SLZ-KF12NA	•	•	•	•	•	•
		SLZ-KF15NA		•	•	•	•	•
	Horizontal-ducted	SEZ-KD09NA4	•	•	•	•*6	•*6	•*6
SEZ-KD12NA4		•	•	•	•*6	•*6	•*6	
SEZ-KD15NA4		•	•	•	•*6	•*6	•*6	
SEZ-KD18NA4			•	•	•*6	•*6	•*6	
P-Series	4-way Cassette	PLA-A12EA7				•*5	•*5	•*5
		PLA-A18EA7		•	•	•*5	•*5	•*5
		PLA-A24EA7				•*5	•*5	•*5
		PLA-A30EA7				•*5	•*5	•*5
		PLA-A36EA7				•*5	•*5	•*5
		PLA-A42EA7						
	Ceiling Suspended	PCA-A24KA7			•			
		PCA-A30KA7						
		PCA-A36KA7						
		PCA-A42KA7						
	Horizontal-ducted	PEAD-A12AA7	•*3	•*3	•*3	•*6	•*6	•*6
		PEAD-A18AA7		•	•*3	•*6	•*6	•*6
		PEAD-A24AA7			•	•*6	•*6	•*6
		PEAD-A30AA7				•*6	•*6	•*6
		PEAD-A36AA7				•*6	•*6	•*6
PEAD-A42AA7								
Branch Box	3 port	PAC-MKA32BC					•	•
	5 port	PAC-MKA52BC					•	•

Information is current as of this printing. Minimum installed capacity cannot be less than 12,000 Btu/h. A minimum of two indoor units must be connected to all MXZ-C outdoor units.

\*2 Only one SVZ Model can be connected.

\*3 Maximum of two units can be connected unless the SPTB1 is utilized to power the indoor unit.

\*4 Single unit can be connected.

\*5 When the system includes even 1 unit of PLA-A-EA7, the number of the maximum connectable

indoor units is decreased as follows: 3 for MXZ-4C36NAHZ, 4 for MXZ-5C42NAHZ, and 6 for MXZ-8C48NA(HZ) and MXZ-8C60NA.

\*6 Maximum of 3 horizontal ducted indoor units (PEAD or SEZ) can be connected.

\*7 Maximum of 2 horizontal ducted indoor units (PEAD or SEZ) can be connected.

For more information, please refer to the service manual, application 1039 and the full compatibility chart on mylinkdrive.



# Conditions

# Conditions for Specifications

Temperature conditions are based on AHRI 210/240.

Cooling	Indoor	D.B. 80° F (27° C), W.B. 67° F (19° C)
	Outdoor	D.B. 95° F (35° C), W.B. 75° F (24° C)
Heating	Indoor	D.B. 70° F (21° C), W.B. 60° F (16° C)
	Outdoor	D.B. 17° F (-8° C), W.B. 15° F (-9° C)

Refrigerant piping length: 16 ft.

The figures for total input are based on the following voltages.

Series	Indoor unit	Outdoor unit
M Series P Series MXZ-C Model	-	208 / 230V • Single phase • 60Hz

Sound pressure level

- The sound pressure measurement is conducted in an anechoic chamber.
- The actual sound level depends on the distance from the unit and the acoustic environment.

## How to Read a Model Name

### 1) M-Series MSZ-EF12NAW

<b>M</b>	M or S: M-Series
<b>S</b>	S= Wall-mounted, F= Compact floor-standing, E= Compact ceiling-concealed, L= 4- or 1-way cassette, U= Outdoor unit
<b>Z</b>	Z= Inverter heat pump, H= Fixed-speed heat pump, Y= Cooling only
-	
<b>E</b>	Series
<b>F</b>	Generation
<b>12</b>	Rated cooling capacity (KBTU/H base)
<b>N</b>	208 / 230V • Single phase • 60Hz
<b>A</b>	A= R410A with new A control
<b>W</b>	HZ= Hyper Heating model, H= Anti-freeze heater equipped model/base heater, S= Silver indoor unit, W= White indoor unit, B= Black indoor unit

### 2) P-Series PUZ-A18NKA

<b>P</b>	P Series
<b>U</b>	K= Wall-mounted, S= Floor-standing, L= 4-way cassette, E= Ceiling-concealed, C= Ceiling-suspended, U= Outdoor unit
<b>Z</b>	Z= For heating and cooling, Y= Cooling only
-	
<b>A</b>	A=Standard HA=Hyper heating
<b>18</b>	Rated cooling capacity (KBTU/H base)
<b>N</b>	208 / 230V • Single phase • 60Hz
<b>K</b>	Generation
<b>A</b>	A= A control
<b>7</b>	7= Generation

### 3) MXZ-C Model MXZ-4C36NAHZ

<b>M</b>	M Series
<b>X</b>	Multi-system outdoor unit (heat pump)
<b>Z</b>	Inverter heat pump
-	
<b>4</b>	Maximum number of connectable indoor units
<b>C</b>	Generation
<b>36</b>	Rated cooling capacity (KBTU/H base)
<b>N</b>	208 / 230V • Single phase • 60Hz
<b>A</b>	A= R410A with new A control
<b>HZ</b>	HZ= Hyper Heating model

# Piping Installation

## M-Series

Single type

Series	Class <Outdoor unit>	Maximum Piping Length (ft)	Maximum Height Difference (ft)	Maximum Number of Bends
		Total length (A)	Outdoor unit - Indoor unit (H)	Total number
MUZ-FH	06/09/12	65	40	10
	15/18	100	50	10
MUZ/MUY-GL	09/12/15	65	40	10
	18/24	100	50	10
MUZ/MUY-HM	09/12/15/18	65	40	10
	24	100	50	10
MUFZ-KJ	09/12	65	40	10
	15/18	100	50	10
SUZ-KA-NA2/NAHZ	09/12/15	65	40	10
	18	100	50	10
	24/30/36	100	100	10

## P-Series

Single type

Series	Class <Outdoor unit>	Maximum Piping Length (ft)	Maximum Height Difference (ft)	Maximum Number of Bends
		Total length (A)	Outdoor unit - Indoor unit (H)	Total number
PUY	12/18	165	100	15
	24/30/36/42	225		15
PUZ	12/18	100	100	15
	24/30/36/42	165		15
PUZ-HA	24	165	100	15
PUZ-HA	30/36/42	245	100	15



# MXZ Model

## MXZ-2C20NA2

Maximum Piping Length	
Outdoor unit - Indoor unit (a,b)	82 ft.
Total length (a+b)	164 ft.

Maximum Number of Bends	
Outdoor unit - Indoor unit (a,b)	25
Total number (a+b)	50

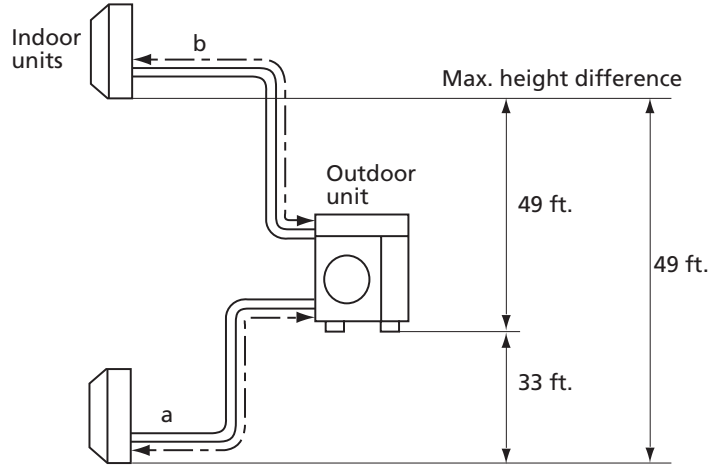

## MXZ-2C20NAHZ2

Maximum Piping Length	
Outdoor unit - Indoor unit (a,b)	82 ft.
Total length (a+b)	164 ft.

Maximum Number of Bends	
Outdoor unit - Indoor unit (a,b)	25
Total number (a+b)	50

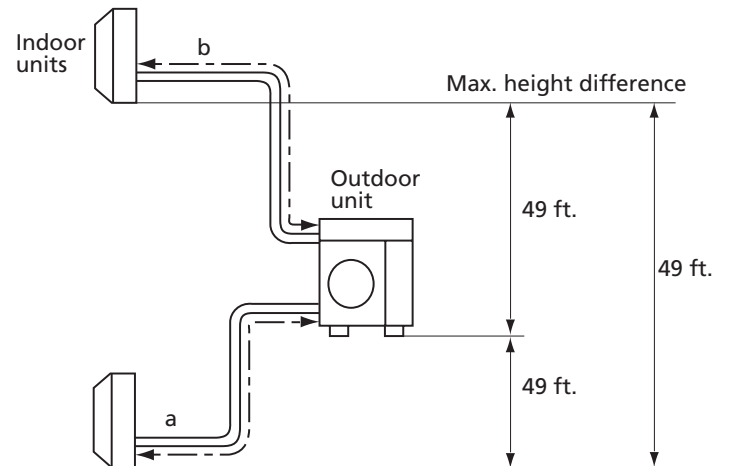

## MXZ-3C24NA2, MXZ-3C30NA2, MXZ-3C24NAHZ2, MXZ-3C30NAHZ2

Maximum Piping Length	
Outdoor unit - Indoor unit (a,b,c)	82 ft.
Total length (a+b+c)	230 ft.

Maximum Number of Bends	
Outdoor unit - Indoor unit (a,b,c)	25
Total number (a+b+c)	70

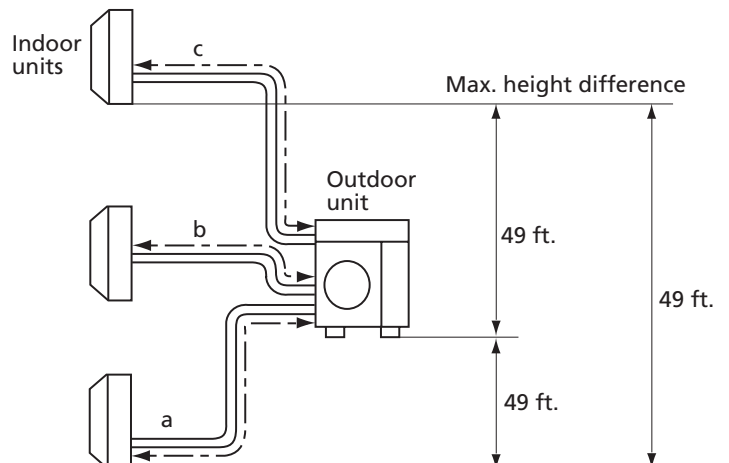

# MXZ Model

## MXZ-4C36NA2

Maximum Piping Length	
Outdoor unit - Indoor unit (a,b,c,d)	82 ft.
Total length (a+b+c+d)	230 ft.

Maximum Number of Bends	
Outdoor unit - Indoor unit (a,b,c,d)	25
Total number (a+b+c+d)	70

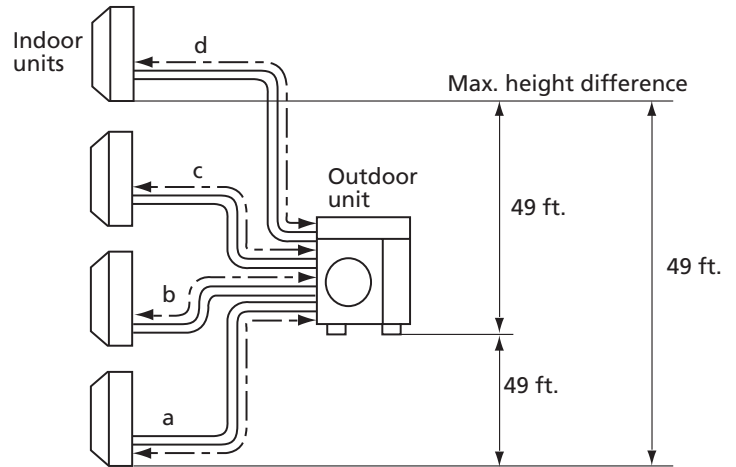

## MXZ-5C42NA2

Maximum Piping Length	
Outdoor unit - Indoor unit (a,b,c,d,e)	82 ft.
Total length (a+b+c+d+e)	262 ft.

Maximum Number of Bends	
Outdoor unit - Indoor unit (a,b,c,d,e)	25
Total number (a+b+c+d+e)	80

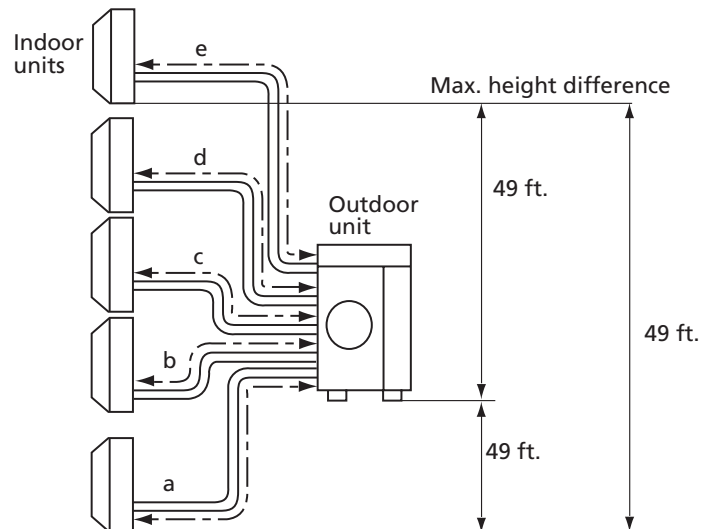

**MXZ-4C36NAHZ2, MXZ-5C42NAHZ2, MXZ-8C48NAHZ2,  
MXZ-8C48NA2, MXZ-8C60NA2**

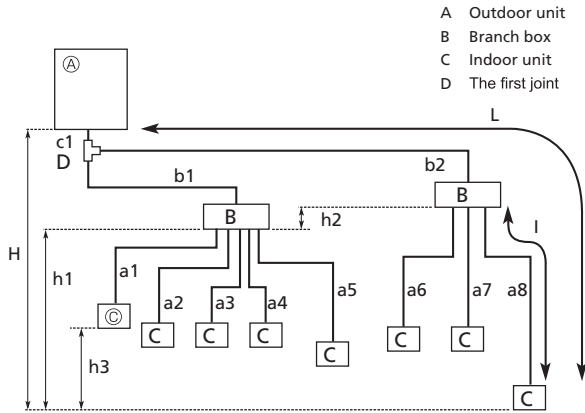

- A Outdoor unit
- B Branch box
- C Indoor unit
- D The first joint

Permissible length (one-way)	Total piping length	$c1 + b1 + b2 + a1 + a2 + a3 + a4 + a5 + a6 + a7 + a8 \leq 150 \text{ m (492 ft.)}$
	Farthest piping length (L) *1	$c1 + b2 + a8 \leq 80 \text{ m (262 ft.)}$
	Piping length between outdoor unit and branch boxes	$c1 + b1 + b2 \leq 55 \text{ m (180 ft.)}$
	Farthest branch box from the first joint (b2)	$b2 \leq 30 \text{ m (98 ft.)}$
	Farthest piping length after branch box (I)	$a8 \leq 25 \text{ m (82 ft.)}$
	Total piping length between branch boxes and indoor units	$a1 + a2 + a3 + a4 + a5 + a6 + a7 + a8 \leq 95 \text{ m (311 ft.)}$
Permissible height difference (one-way)	In indoor/outdoor section (H) *2	$H \leq 50 \text{ m (164 ft.) (In case of outdoor unit is set higher than indoor unit)}$ $H \leq 40 \text{ m (131 ft.) (In case of outdoor unit is set lower than indoor unit)}$
	In branch box/indoor unit section (h1)	$h1 + h2 \leq 15 \text{ m (49 ft.)}$
	In each branch unit (h2)	$h2 \leq 15 \text{ m (49 ft.)}$
	In each indoor unit (h3)	$h3 \leq 12 \text{ m (39 ft.)}$
Number of bends		$ c1 + b1 + a1 ,  c1 + b1 + a2 ,  c1 + b1 + a3 ,  c1 + b1 + a4 ,  c1 + b1 + a5 ,  c1 + b2 + a6 ,  c1 + b2 + a7 ,  c1 + b2 + a8  \leq 15$

\*1 The piping specification table does not provide a minimum line set length. However, indoor units with connected piping length less than 16 ft. (5 m) could produce intermittent noise during normal system operation in very quiet environments. Please be aware of this important information when installing and locating the indoor unit within the conditioned space.

\*2 Branch box should be placed within the level between the outdoor unit and indoor units.

# Explanation of Terminology

## Maximum Piping Length

---

This is the maximum allowable length of the refrigerant piping. The amount of refrigerant pipe used cannot be longer than the length specified.

- **Total Length**

The maximum allowable combined length of all the refrigerant piping between the outdoor unit and indoor unit(s).

- **Outdoor Unit - Indoor Unit**

The maximum allowable length of the refrigerant piping between the outdoor unit and indoor units installed when multiple units are connected to a single outdoor unit. This distance limitation refers to the maximum length between the outdoor unit and the farthest indoor unit.

- **Pipe Length Difference From Distribution Pipe**

The maximum allowable difference in refrigerant piping length from the distribution pipe to the farthest indoor unit and from the distribution pipe to the closest indoor unit when multiple indoor units are connected to a single outdoor unit using a distribution pipe.

- **Indoor Unit - Distribution Pipe**

The maximum allowable length of the refrigerant piping between indoor units and the distribution pipe when multiple indoor units are connected to a single outdoor unit.

## Maximum Height Difference

---

This is the maximum allowable height difference. It is necessary to install the air conditioning system so that the height distance is no more than the difference specified. (Specified differences may vary if the outdoor unit is installed higher or lower than the indoor units).

- **Outdoor Unit - Indoor Unit**

The maximum allowable difference in height between the outdoor unit and indoor units when installed (when multiple indoor units are connected to a single outdoor unit, this distance limitation refers to the maximum height difference between the outdoor unit and an indoor unit).

- **Indoor Unit - Indoor Unit**

The maximum allowable difference between the heights of indoor units when multiple indoor units are connected to a single outdoor unit.

## Maximum Number Of Bends

---

This is the maximum allowable number of bends in the refrigerant piping. The total number of bends in the refrigerant piping used cannot exceed the number specified.

- **Total Number**

The maximum allowable number of bends for all refrigerant piping between the outdoor unit and indoor units.

- **Outdoor Unit - Indoor Unit**

The maximum allowable number of bends between the outdoor unit and each indoor unit when multiple indoor units are connected to a single outdoor unit.



MITSUBISHI ELECTRIC





# Appendix



# 3 Important Points to Remember When Installing the Outdoor Unit

Wind and snow can significantly reduce capacity. Be sure to check the information below and install the outdoor unit correctly.

## 1 Installation Location

Be aware of the prevailing wind direction in winter and install the outdoor unit where it is as sheltered as possible.

Units are easily affected by wind and unit may not be able to run at full capacity

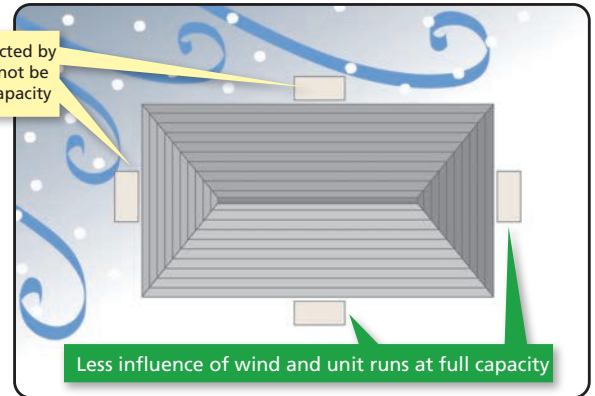

## 2 Measures for Drainage of Water

### Case 1: Unit is installed close to passage (walkway)

Do not install the unit close to passage as drainage water from the unit may freeze and cause a slipping hazard.

**Correct installation**

**Note**

- ① Install at a sufficient height from the ground to prevent problems caused by frozen drainage water.
- ② Install in a location where frozen drainage water will not be a hazard.
- ③ Install in an upright position to allow proper drainage from the drainage outlet.

**Wrong installation**

Drainage water splashes on pedestrians.

Frozen drainage water may cause a slipping hazard.

**Wrong installation**

Unit may freeze and become damaged because water will not be drained from the drain hole.

### Case 2: Multiple units are installed

Do not install units on top of one another as it may cause frozen drainage water on the bottom unit.

**Correct installation**

**Note**  
Place units side by side.

**Wrong installation**

Bottom unit may freeze.

### 3 Measures for Snow

#### Do not install the unit on the ground

To avoid the adverse effects of snow and frozen drainage water, install the unit on a stand to ensure a sufficient height from the ground.

**Correct installation**

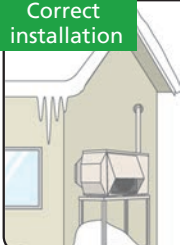

**Note**

- ① Install at a position/height to prevent the unit being buried in snow\*1 and the adverse effects of frozen drainage water.\*2
- ② Install so as to avoid the effects of snow or snowdrift.
- ③ Install so as to avoid the damage from falling snow or icicles.

\*1 Install at a height above the highest snowfall depth.  
\*2 Even for correct installations, dripping drainage water may form an icicle which needs to be cleared away regularly to prevent a blocked drainage outlet.

**Wrong installation**



Unit may become buried in snow due to heavy snowfall, snow sliding off the roof or snowdrift.

**Wrong installation**



Unit may be damaged due to snowfall or icicles.

Use a stand to add sufficient height to protect the unit heat exchanger from snow and prevent icicles forming during defrost operation.

#### Install snow protection hood as necessary

**Correct installation**

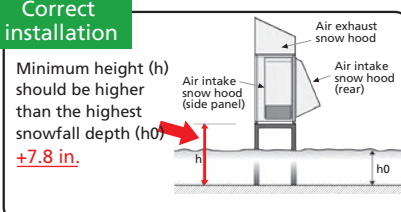

Minimum height (h) should be higher than the highest snowfall depth (h0) **+7.8 in.**

**Wrong installation**

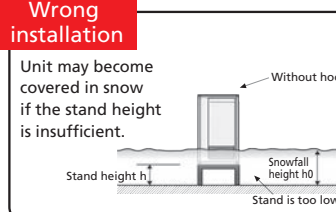

Unit may become covered in snow if the stand height is insufficient.

**Correct installation**

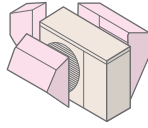

**Note**  
Install the snow protection hood or other cover in snowy regions.

#### Recommended accessories (drain socket & centralized drain pan, stand, snow protection hood, base heater)

	Snowy region	Cold region	Remarks
	Countermeasures for snow	Countermeasures for freezing	
Drain socket, Centralized drain pan	Not used	Not used	Prevents freezing
Stand	Needed	Needed	1. Install so as to prevent the unit being buried in snow (at a height greater than the highest snowfall depth). Be sure that the stand does not obstruct drainage. 2. Install so as to prevent damage to the unit due to frozen drainage water (icicles).
Snow protection hood	Needed *When the installation position is subject to snowfall.	—	1. Prevents heat exchanger from being covered in snow. 2. Prevents snow accumulating inside the air duct.
Base heater	—	Needed	Outdoor units equipped with a heater for cold regions are those with an "H" in the model name. For the cold-climate zone, use of a unit with a heater is strongly recommended. Even for the moderate-climate zone use of a unit with a heater is recommended for regions subject to high humidity in winter.

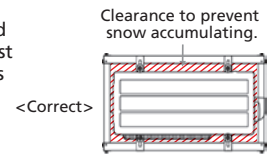

### **CAUTION** About disposal of drainage water

When the unit is installed in cold or snowy regions :

**Drainage water may freeze in the drain socket/hose and prevent the fan from rotating.**



**Do not attach a drain socket packaged as an accessory to the unit.**

\* In the case that fitting a drain socket is absolutely necessary, steps must be taken so that the drainage water does not freeze. For more information, please consult Mitsubishi Electric Trane HVAC US or one of its dealers/resellers.





Arrangement for snow protection hood

Separately sold parts are available for some models. Please consult Mitsubishi Electric Trane HVAC US or one of its dealers/resellers at the time of purchase for details.

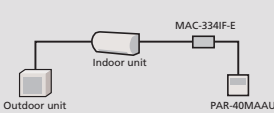
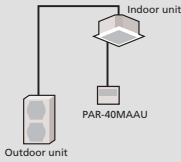

# System Control

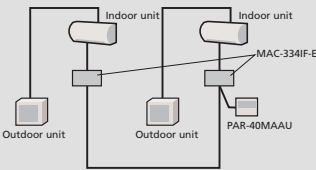
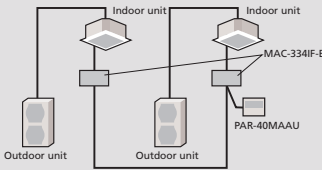
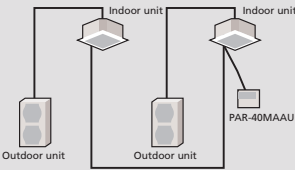
Versatile system controls can be achieved by using optional parts, relay circuits, control panels, etc.

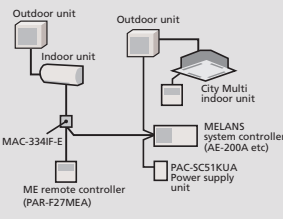
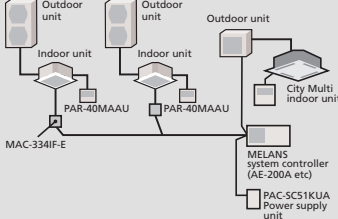
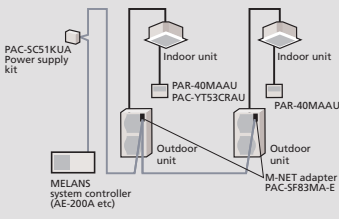
		System Examples		
Indoor Unit	M Series Indoor Unit	SEZ, SLZ, SVZ	P Series Indoor Unit	
Outdoor Unit	M Series and MXZ Series Outdoor	SUZ and MXZ Series Outdoor		P Series Outdoor
 <p><b>PAR-40MAAU Control</b></p>				
Details	<ul style="list-style-type: none"> <li>Wired remote controller can be connected to indoor unit</li> </ul>	Standard equipment (for indoor units compatible with wired remote controllers)		
Major Optional Parts Required	<ul style="list-style-type: none"> <li>MAC-334IF-E (Interface)</li> <li>PAR-40MAAU (Wired remote controller)</li> </ul>	<ul style="list-style-type: none"> <li>PAR-40MAAU (Wired remote controller)</li> </ul>		
 <p><b>System Group Control</b></p>				
Details	<ul style="list-style-type: none"> <li>One remote controller can control plural air conditioners with the same settings simultaneously.</li> <li>One remote controller can control up to 16 refrigerant systems. (When connected to a MXZ unit, MAC-334IF-E is counted as one system.)</li> <li>Up to two remote controller can be connected.</li> </ul>			
Major Optional Parts Required	<ul style="list-style-type: none"> <li>MAC-334IF-E (Interface)</li> <li>PAR-40MAAU (Wired remote controller)</li> </ul>	<ul style="list-style-type: none"> <li>PAR-40MAAU (Wired remote controller)</li> </ul>		
 <p><b>M-NET Connections</b></p>				
Details	<ul style="list-style-type: none"> <li>Group of air conditioners can be controlled by MELANS system controller (M-NET).</li> </ul> <p>Note: When connecting to M-NET, the reduction control for the power failure automatic recovery does not operate and it will take 3 minutes to re</p>			
Major Optional Parts Required	<ul style="list-style-type: none"> <li>MAC-334IF-E (M-NET Interface)</li> <li>MELANS System controller</li> <li>PAC-SCS1KUA (power supply unit)</li> </ul>	<ul style="list-style-type: none"> <li>PAC-SJ95MA-E/PAC-SJ96MA-E (M-NET converter)</li> <li>MELANS System controller</li> <li>PAC-SCS1KUA (power supply unit)</li> </ul>		

# For M-Series Indoor Units

	System Examples	Connection Details	Control Details	Major Optional Parts Required
<b>1 Remote On/Off Operation</b> <ul style="list-style-type: none"> <li>Air conditioner can be started/stopped remotely. (1) and (2) can be used in combination</li> </ul>		Connect the interface to the air conditioner. Then connect the locally purchased remote controller to the terminal in the interface.	On/Off operation is possible from a remote location.	<ul style="list-style-type: none"> <li>MAC-334IF-E (Interface)</li> <li>Parts for circuit such as relay box, lead wire, etc. (to be purchased locally)</li> </ul>
<b>2 Remote Display of Operation Status</b> <ul style="list-style-type: none"> <li>The On/Off status of air conditioners can be confirmed remotely. (1) and (2) can be used in combination</li> </ul>		Connect the interface to the air conditioner. Then connect the locally purchased remote controller to the terminal in the interface.	The operation status (On/Off) or error signals can be monitored from a remote location.	<ul style="list-style-type: none"> <li>MAC-334IF-E (Interface)</li> <li>Parts for circuit to be purchased locally (DC power source needed)</li> <li>External power source (12V DC) is required when using MAC-334IF-E.</li> </ul>



# For P-Series and SLZ, SEZ and SVZ Indoor Units

	System Examples		Details	Major Optional Parts Required
	Wired remote controller	Wireless remote controller		
<b>A 2-remote Controller Control</b> <p>With two remote controllers, control can be performed locally and remotely from two locations.</p>	<p>* Set "Main" and "Sub" remote controllers. (Example of 1 : 1 system)</p>	<p>* When using wired and wireless remote controllers (Example of Simultaneous Twin)</p>	<ul style="list-style-type: none"> <li>Up to two remote controllers can be connected to one group.</li> <li>Both wired and wireless remote controllers can be used in combination.</li> </ul>	<ul style="list-style-type: none"> <li>Wired Remote Controller PAR-40MAAU</li> <li>Wireless Remote Controller PAR-FL32MA</li> <li>Wireless Remote Controller Kit for PCA PAR-SL93B-E</li> </ul>
<b>B Operation Control by Level Signal</b> <p>Air conditioner can be started/stopped remotely. In addition, On/Off operation by local remote controller can be prohibited/permitted.</p>	<p>(Example of 1 : 1 system x 2)</p>	<p>(Example of 1 : 1 system x 2)</p>	<ul style="list-style-type: none"> <li>Operation other than On/Off (e.g., adjustment of temperature, fan speed, and airflow) can be performed even when remote controller operation is prohibited.</li> <li>Timer control is possible with an external timer.</li> </ul>	<ul style="list-style-type: none"> <li>Adapter for remote On/Off PAC-SE55RA-E</li> <li>Relay box (to be purchased locally)</li> <li>Remote control panel (to be purchased locally)</li> </ul>
<b>C Operation Control by Pulse Signal</b>	<p>(Example of 1 : 1 system x 2)</p>	<p>(Example of 1 : 1 system x 2)</p>	<ul style="list-style-type: none"> <li>The pulse signal can be turned On/Off.</li> <li>Operation/emergency signal can be received at a remote location.</li> </ul>	<ul style="list-style-type: none"> <li>Connector cable for remote display PAC-SA88HA-E / PAC-725AD (10 pcs. x PAC-SA88HA-E)</li> <li>Relay box (to be purchased locally)</li> <li>Remote control panel (to be purchased locally)</li> </ul>
<b>D Remote Display of Operating Status</b> <p>Operating status can be displayed at a remote location.</p>	<p>(Example of 1 : 1 system)</p>	<p>(Example of Simultaneous Twin)</p>	<ul style="list-style-type: none"> <li>Operation/emergency signal can be received at a remote location (when channeled through the PAC-SF40RM-E→ no-voltage signal, when channeled through the PAC-SA88HA-E→ DC 12V signal).</li> </ul>	<ul style="list-style-type: none"> <li>Remote display panel (to be purchased locally)</li> <li>Connector cable for remote display PAC-SA88HA-E / PAC-725AD (10 pcs. x PAC-SA88HA-E)</li> <li>Relay box (to be purchased locally)</li> <li>Remote operation adapter PAC-SF40RM-E</li> <li>*Unable to use with wireless remote controller</li> </ul>
<b>E Timer Operation</b> <p>Allows On/Off operation with timer *For control by an external timer, refer to B Operation Control by Level Signal.</p>	<p>(Example of 1 : 1 system)</p>		<ul style="list-style-type: none"> <li><b>Weekly Timer:</b> On/Off and up to 8 pattern temperatures can be set for each calendar day. (Initial setting)</li> <li><b>On/Off Timer:</b> On/Off can be set once each within 72 hr in intervals of 5-minute units.</li> <li><b>Auto-off Timer:</b> Operation will be switched off after a certain time elapse. Set time can be changed from 30 min. to 4 hr. at 10 min. intervals.</li> </ul>	Standard functions of PAR-40MAAU

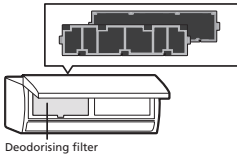
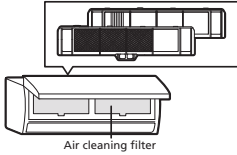
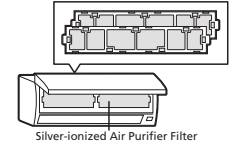
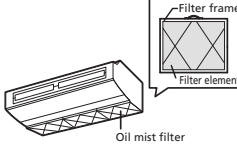
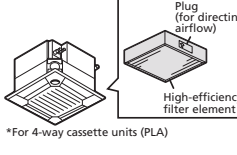
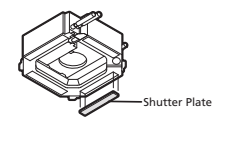
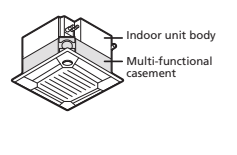
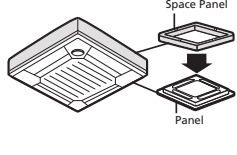
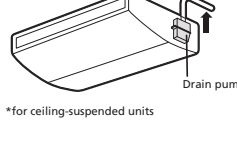

# Other Optional Parts

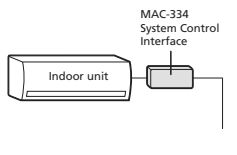
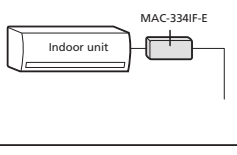
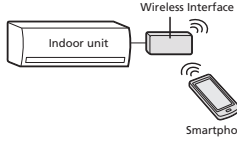
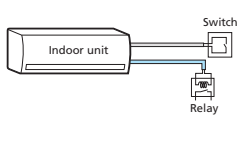
Part Name	Description
<b>Deodorizing Filter</b> Captures small foul-smelling substances in the air.	 Deodorising filter
<b>Air cleaning Filter</b> Removes fine dust particles from the air by means of static electricity.	 Air cleaning filter
<b>Silver-ionized Air Purifier Filter</b> Captures the bacteria, pollen and other allergens in the air and neutralizes them.	 Silver-ionized Air Purifier Filter
<b>Oil Mist Filter Element</b> Filter element (12 pieces) that blocks the oil mist for ceiling-suspended models used in professional kitchens.	 Oil mist filter
<b>High-efficiency Filter Element</b> Element for high-efficiency filter. Removes fine dust particles from the air.	 *For 4-way cassette units (PLA)
<b>Shutter Plate</b> Plate for blocking an air outlet of the 4-way cassette (PLA) indoor unit.	 Shutter Plate
<b>Multi-functional Casement</b> Casement for fresh-air intake and attaching the high-efficiency filter element (optional).	 Indoor unit body Multi-functional casement
<b>Space Panel</b> Decorative cover for the installation when the ceiling height is low.	 Space Panel Panel
<b>Drain Pump</b> Pumps drain water to a point higher than that where the unit is installed.	 *for ceiling-suspended units Drain pump

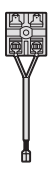
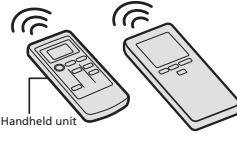
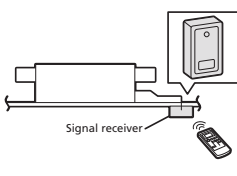
Part Name	Description
<b>MAC-334IF-E System Control Interface</b> Interface for connecting with the PAR-40MAAU remote controller and PACYT53CRAU, and to relay operation signals.	 MAC-334 System Control Interface Indoor unit
Interface to connect with M-NET controllers.	 MAC-334IF-E Indoor unit
<b>kumo cloud® Wireless Interface 2</b> Interface enabling users to control air conditioners and check operating status via devices such as personal computers, tablets and smart phones.	 Wireless Interface 2 Indoor unit Smartphone
<b>CN24 Relay Kit</b> This product is an adaptor which inputs the incoming signals from an open/close switch to the air conditioner and outputs the on/off signals from the air conditioner to the back-up heater.	 Indoor unit Switch Relay
<b>Deluxe MA Wired Controller</b> Advanced deluxe remote controller with full dot liquid-crystal display and backlight. Equipped with convenient functions like	
<b>Simple MA Wired Controller</b> Remote controller with liquid-crystal display, and backlight function for operation in dark location.	
<b>Remote Controller Terminal Block Kit for PKA</b> The terminal block is used as a relay to wire an indoor unit and to two remote controllers or to wire a remote controller and multiple indoor units in order to perform group control.	
<b>Wireless Remote Controller Signal Sender</b> Handheld unit for sending operation signals to the indoor unit.	 Handheld unit
<b>Wireless Remote Controller Signal Receiver</b> Receives operation signals from the wireless remote controller handheld unit.	 Signal receiver

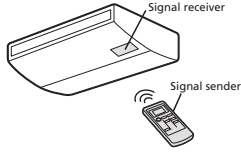
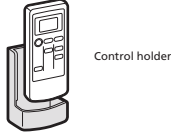
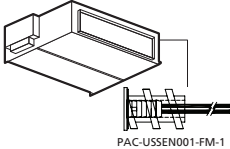
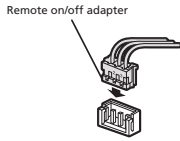
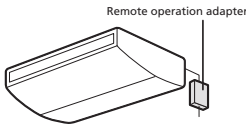
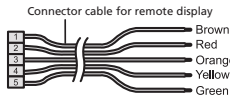
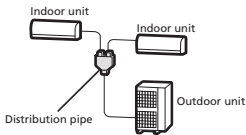
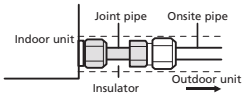
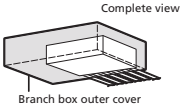
Part Name	Description
<b>Wireless Remote Controller Kit (Sender &amp; Receiver)</b> Remote controller handheld unit (signal sender) and receiver (signal receiver) for ceiling suspended units.	
<b>Control Holder</b> Holder for storing the remote controller.	
<b>Remote Sensor</b> Sensor to detect the room temperature at remote positions.	 PAC-USSEN001-FM-1
<b>PAC-715AD Remote On/Off Adapter</b> Connector for receiving signals from the local system to control the on/off function.	
<b>Remote Operation Adapter</b> Adapter to display the operation status and control on/off function from a distance.	
<b>PAC-725AD Connector Plug for Remote Display</b> Connector used to display the operation status and control on/off function from a distance.	
<b>Distribution Pipe</b> Branch pipe for P Series simultaneous multi-unit system use, or to connect two branch boxes for MXZ.	 *P Series with 2 indoor units
<b>Joint Pipe</b> Part for connecting refrigerant pipes of different diameters.	
<b>Branch Box Outer Cover</b> Casement for branch boxes.	

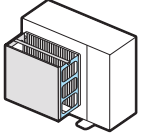
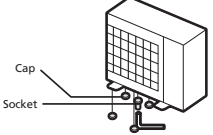
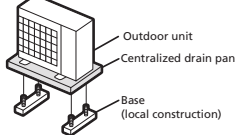
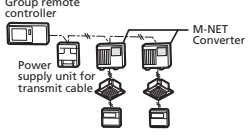
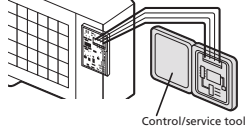
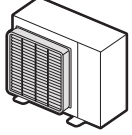
Part Name	Description
<b>Air Protection Guide/Wind Baffle</b> Protects the outdoor unit from the wind.	
<b>Drain Socket</b> A set of caps to cover unnecessary holes at the bottom of the outdoor unit, and a socket to guide drain water to the local drain pipe.	
<b>Centralized Drain Pan</b> Catches drain water generated by the outdoor unit.	
<b>M-NET Converter</b> Used to connect P Series A-control models to M-NET controllers.	
<b>Control/Service Tool</b> Monitoring tool to display operation and service diagnosis data.	
<b>Air Discharge Guide</b> Changes the direction of air being exhausted from the outdoor unit.	

# Optional Parts List for Indoor (M-Series)

			Wall Mount								
			MSZ-FS					MSZ-EF			
			MSZ-FS06NA	MSZ-FS09NA	MSZ-FS12NA	MSZ-FS15NA	MSZ-FS18NA	MSZ-EF09NA(B/S/W)	MSZ-EF12NA(B/S/W)	MSZ-EF15NA(B/S/W)	MSZ-EF18NA(B/S/W)
Condensate	Blue Diamond (Advanced) Mini Condensate Pump w/ Reservoir & Sensor (208/230V) [recommended]	X87-721	•	•	•	•	•	•	•	•	•
	Blue Diamond (MicroBlue) Mini Condensate Pump (110/208/230V) up to 18,000 BTU/H	X85-003	•	•	•	•	•	•	•	•	•
	Blue Diamond Alarm Extension Cable—6.5 Ft.	C13-192	•	•	•	•	•	•	•	•	•
	Blue Diamond MultiTank — collection tank for use with multiple pumps	C21-014	•	•	•	•	•	•	•	•	•
	Blue Diamond Sensor Extension Cable — 15 Ft.	C13-103	•	•	•	•	•	•	•	•	•
	Drain Pan Level Sensor/Control	SS610E	•	•	•	•	•	•	•	•	•
	Fascia Kit for MicroBlue Pump, mounts the MicroBlue and sensor directly beneath indoor unit	T18-016	•	•	•	•	•				
Disconnect Switch	Sauermann Condensate Pump	SI30-230	•	•	•	•	•	•	•	•	•
	(30A/600V/UL) [fits 2" X 4" utility box] - Black	TAZ-MS303	•	•	•	•	•				
Filter	(30A/600V/UL) [fits 2" X 4" utility box] - White	TAZ-MS303W	•	•	•	•	•	•	•	•	•
	Electro Static Anti-allergy Enzyme Filter	MAC-2320FT-E	•	•	•	•	•	•	•	•	•
Lineset	Platinum Deodorizing Filter	MAC-3000FT-E	•	•	•	•	•				
	100' x 1/4" x 100' / 1/2" Lineset (Twin-Tube Insulation)	MLS141212T-100								•	•
	15' x 1/4" x 15' / 1/2" Lineset (Twin-Tube Insulation)	MLS141212T-15			•	•	•			•	•
	15' x 1/4" x 15' / 3/8" Lineset (Twin-Tube Insulation)	MLS143812T-15	•	•				•	•		
	30' x 1/4" x 30' / 1/2" Lineset (Twin-Tube Insulation)	MLS141212T-30			•	•	•			•	•
	30' x 1/4" x 30' / 3/8" Lineset (Twin-Tube Insulation)	MLS143812T-30	•	•				•	•		
	50' x 1/4" x 50' / 1/2" Lineset (Twin-Tube Insulation)	MLS141212T-50			•	•	•			•	•
	50' x 1/4" x 50' / 3/8" Lineset (Twin-Tube Insulation)	MLS143812T-50	•	•				•	•		
	65' x 1/4" x 65' / 1/2" Lineset (Twin-Tube Insulation)	MLS141212T-65			•	•	•			•	•
65' x 1/4" x 65' / 3/8" Lineset (Twin-Tube Insulation)	MLS143812T-65	•	•				•	•			
Soft Dry Cloth	Soft Dry Cloth	MAC-1001CL-E						•	•	•	•

			Wall Mount							
			MSZ-GL					MSZ-D		
			MSZ-GL06NA	MSZ-GL09NA	MSZ-GL12NA	MSZ-GL15NA	MSZ-GL18NA	MSZ-GL24NA	MSZ-D30NA	MSZ-D36NA
Condensate	Blue Diamond (Advanced) Mini Condensate Pump w/ Reservoir & Sensor (208/230V) [recommended]	X87-721	•	•	•	•	•	•	•	•
	Blue Diamond (MegaBlue Advanced) Condensate Pump w/ Reservoir & Sensor	X87-835						•	•	•
	Blue Diamond (MicroBlue) Mini Condensate Pump (110/208/230V) up to 18,000 BTU/H	X85-003	•	•	•	•	•			
	Blue Diamond Alarm Extension Cable—6.5 Ft.	C13-192	•	•	•	•	•	•	•	•
	Blue Diamond MultiTank — collection tank for use with multiple pumps	C21-014	•	•	•	•	•	•	•	•
	Blue Diamond Sensor Extension Cable — 15 Ft.	C13-103	•	•	•	•	•	•	•	•
	Drain Pan Level Sensor/Control	SS610E	•	•	•	•	•	•	•	•
	Fascia Kit for MicroBlue Pump, mounts the MicroBlue and sensor directly beneath indoor unit	T18-016	•	•	•	•	•	•	•	•
Saueremann Condensate Pump	SI30-230	•	•	•	•	•	•	•	•	
Controller Holder	Remote Controller Holder	U01A01083	•	•	•	•				
Disconnect Switch	(30A/600V/UL) [fits 2" X 4" utility box] - Black	TAZ-MS303	•		•	•	•	•	•	•
	(30A/600V/UL) [fits 2" X 4" utility box] - White	TAZ-MS303W	•	•	•	•	•	•	•	•
Filter	Anti-allergy Enzyme Filter	MAC-408FT-E	•	•	•	•	•			
	Electro Static Anti-allergy Enzyme Filter	MAC-2310FT-E						•		
Lineset	10' x 3/8" x 10' x 5/8" Lineset (Twin-Tube Insulation)	MPLS385812T-10						•	•	•
	100' x 1/4" x 100' / 1/2" Lineset (Twin-Tube Insulation)	MLS141212T-100				•	•			
	100' x 3/8" x 100' x 5/8" Lineset (Twin-Tube Insulation)	MPLS385812T-100						•	•	•
	15' x 1/4" x 15' / 1/2" Lineset (Twin-Tube Insulation)	MLS141212T-15				•	•			
	15' x 1/4" x 15' / 3/8" Lineset (Twin-Tube Insulation)	MLS143812T-15	•	•	•					
	15' x 3/8" x 15' x 5/8" Lineset (Twin-Tube Insulation)	MPLS385812T-15						•	•	•
	30' x 1/4" x 30' / 1/2" Lineset (Twin-Tube Insulation)	MLS141212T-30				•	•			
	30' x 1/4" x 30' / 3/8" Lineset (Twin-Tube Insulation)	MLS143812T-30	•	•	•					
	30' x 3/8" x 30' x 5/8" Lineset (Twin-Tube Insulation)	MPLS385812T-30						•	•	•
	50' x 1/4" x 50' / 1/2" Lineset (Twin-Tube Insulation)	MLS141212T-50				•	•			
	50' x 1/4" x 50' / 3/8" Lineset (Twin-Tube Insulation)	MLS143812T-50	•	•	•					
	50' x 3/8" x 50' x 5/8" Lineset (Twin-Tube Insulation)	MPLS385812T-50						•	•	•
	65' x 1/4" x 65' / 1/2" Lineset (Twin-Tube Insulation)	MLS141212T-65				•	•			
	65' x 1/4" x 65' / 3/8" Lineset (Twin-Tube Insulation)	MLS143812T-65	•	•	•					
	65' x 3/8" x 65' x 5/8" Lineset (Twin-Tube Insulation)	MPLS385812T-65						•	•	•

# Optional Parts List for Indoor (M-Series)

			Wall Mount										
			MSZ-HM					MSZ-JP		MSZ-WR			
			MSZ-HM09NA	MSZ-HM12NA	MSZ-HM15NA	MSZ-HM18NA	MSZ-HM24NA	MSZ-JP09WA	MSZ-JP12WA	MSZ-WR09NA	MSZ-WR12NA	MSZ-WR18NA	MSZ-WR24NA
Condensate	Blue Diamond (Advanced) Mini Condensate Pump w/ Reservoir & Sensor (208/230V) [recommended]	X87-721	•	•	•	•	•	•	•	•	•	•	•
	Blue Diamond (MegaBlue Advanced) Condensate Pump w/ Reservoir & Sensor	X87-835					•						•
	Blue Diamond (MicroBlue) Mini Condensate Pump (110/208/230V) up to 18,000 BTU/H	X85-003	•	•	•	•		•	•	•	•	•	
	Blue Diamond Alarm Extension Cable—6.5 Ft.	C13-192	•	•	•	•	•	•	•	•	•	•	•
	Blue Diamond MultiTank — collection tank for use with multiple pumps	C21-014	•	•	•	•	•	•	•	•	•	•	•
	Blue Diamond Sensor Extension Cable — 15 Ft.	C13-103	•	•	•	•	•	•	•	•	•	•	•
	Drain Pan Level Sensor/Control	SS610E	•	•	•	•	•	•	•	•	•	•	•
	Fascia Kit for MicroBlue Pump, mounts the MicroBlue and sensor directly beneath indoor unit Saueremann Condensate Pump	T18-016	•	•	•	•	•	•	•	•	•	•	•
Controller Holder	Remote Controller Holder	SI30-230	•	•	•	•	•	•	•	•	•	•	•
Disconnect Switch	(30A/600V/UL) [fits 2" X 4" utility box] - Black	U01A01083	•	•	•	•	•	•	•	•	•	•	•
	(30A/600V/UL) [fits 2" X 4" utility box] - White	TAZ-MS303	•	•	•	•	•	•	•	•	•	•	•
Filter	(30A/600V/UL) [fits 2" X 4" utility box] - White	TAZ-MS303W	•	•	•	•	•	•	•	•	•	•	•
	Anti-allergy Enzyme Filter	MAC-408FT-E	•	•	•	•	•	•	•	•	•	•	•
Lineset	10' x 3/8" x 10' x 5/8" Lineset (Twin-Tube Insulation)	MPLS385812T-10					•						•
	100' x 1/4" x 100' / 1/2" Lineset (Twin-Tube Insulation)	MLS141212T-100			•	•						•	
	100' x 3/8" x 100' x 5/8" Lineset (Twin-Tube Insulation)	MPLS385812T-100					•						•
	15' x 1/4" x 15' / 1/2" Lineset (Twin-Tube Insulation)	MLS141212T-15			•	•						•	
	15' x 1/4" x 15' / 3/8" Lineset (Twin-Tube Insulation)	MLS143812T-15	•	•				•	•	•	•		
	15' x 3/8" x 15' x 5/8" Lineset (Twin-Tube Insulation)	MPLS385812T-15					•						•
	30' x 1/4" x 30' / 1/2" Lineset (Twin-Tube Insulation)	MLS141212T-30			•	•						•	
	30' x 1/4" x 30' / 3/8" Lineset (Twin-Tube Insulation)	MLS143812T-30	•	•				•	•	•	•		
	30' x 3/8" x 30' x 5/8" Lineset (Twin-Tube Insulation)	MPLS385812T-30					•						•
	50' x 1/4" x 50' / 1/2" Lineset (Twin-Tube Insulation)	MLS141212T-50			•	•						•	
	50' x 1/4" x 50' / 3/8" Lineset (Twin-Tube Insulation)	MLS143812T-50	•	•				•	•	•	•		
	50' x 3/8" x 50' x 5/8" Lineset (Twin-Tube Insulation)	MPLS385812T-50					•						•
	65' x 1/4" x 65' / 1/2" Lineset (Twin-Tube Insulation)	MLS141212T-65			•	•						•	
	65' x 1/4" x 65' / 3/8" Lineset (Twin-Tube Insulation)	MLS143812T-65	•	•				•	•	•	•		
	65' x 3/8" x 65' x 5/8" Lineset (Twin-Tube Insulation)	MPLS385812T-65					•						•



			Wall Mount						
			MSY-GL					MSY-D	
			MSY-GL09NA	MSY-GL12NA	MSY-GL15NA	MSY-GL18NA	MSY-GL24NA	MSY-D30NA	MSY-D36NA
Condensate	Blue Diamond (Advanced) Mini Condensate Pump w/ Reservoir & Sensor (208/230V) [recommended]	X87-721	•	•	•	•	•	•	•
	Blue Diamond (MegaBlue Advanced) Condensate Pump w/ Reservoir & Sensor	X87-835					•	•	•
	Blue Diamond (MicroBlue) Mini Condensate Pump (110/208/230V) up to 18,000 BTU/H	X85-003	•	•	•	•			
	Blue Diamond Alarm Extension Cable—6.5 Ft.	C13-192	•	•	•	•	•	•	•
	Blue Diamond MultiTank — collection tank for use with multiple pumps	C21-014	•	•	•	•	•	•	•
	Blue Diamond Sensor Extension Cable — 15 Ft.	C13-103	•	•	•	•	•	•	•
	Drain Pan Level Sensor/Control	SS610E	•	•	•	•	•	•	•
	Fascia Kit for MicroBlue Pump, mounts the MicroBlue and sensor directly beneath indoor unit Saueremann Condensate Pump	T18-016	•	•	•	•	•	•	•
Controller Holder	Remote Controller Holder	SI30-230	•	•	•	•	•	•	
Disconnect Switch	(30A/600V/UL) [fits 2" X 4" utility box] - Black	U01A01083	•	•	•				
	(30A/600V/UL) [fits 2" X 4" utility box] - White	TAZ-MS303	•	•	•	•	•	•	•
Filter	Anti-allergy Enzyme Filter	TAZ-MS303W	•	•	•	•	•	•	•
	Electro Static Anti-allergy Enzyme Filter	MAC-408FT-E	•	•	•	•			
Lineset	10' x 3/8" x 10' x 5/8" Lineset (Twin-Tube Insulation)	MAC-2310FT-E					•	•	•
	100' x 1/4" x 100' / 1/2" Lineset (Twin-Tube Insulation)	MPLS385812T-10							
	100' x 3/8" x 100' x 5/8" Lineset (Twin-Tube Insulation)	MLS141212T-100			•	•			
	100' x 3/8" x 100' x 5/8" Lineset (Twin-Tube Insulation)	MPLS385812T-100					•	•	•
	15' x 1/4" x 15' / 1/2" Lineset (Twin-Tube Insulation)	MLS141212T-15			•	•			
	15' x 1/4" x 15' / 3/8" Lineset (Twin-Tube Insulation)	MLS141212T-15	•	•					
	15' x 3/8" x 15' x 5/8" Lineset (Twin-Tube Insulation)	MLS143812T-15					•	•	•
	30' x 1/4" x 30' / 1/2" Lineset (Twin-Tube Insulation)	MPLS385812T-15							
	30' x 1/4" x 30' / 3/8" Lineset (Twin-Tube Insulation)	MLS141212T-30			•	•			
	30' x 3/8" x 30' x 5/8" Lineset (Twin-Tube Insulation)	MLS143812T-30	•	•					
	30' x 3/8" x 30' x 5/8" Lineset (Twin-Tube Insulation)	MPLS385812T-30					•	•	•
	50' x 1/4" x 50' / 1/2" Lineset (Twin-Tube Insulation)	MPLS385812T-30							
	50' x 1/4" x 50' / 3/8" Lineset (Twin-Tube Insulation)	MLS141212T-50			•	•			
	50' x 3/8" x 50' x 5/8" Lineset (Twin-Tube Insulation)	MLS143812T-50	•	•					
	50' x 3/8" x 50' x 5/8" Lineset (Twin-Tube Insulation)	MPLS385812T-50					•	•	•
	65' x 1/4" x 65' / 1/2" Lineset (Twin-Tube Insulation)	MPLS385812T-50							
65' x 1/4" x 65' / 3/8" Lineset (Twin-Tube Insulation)	MLS141212T-65			•	•				
65' x 3/8" x 65' x 5/8" Lineset (Twin-Tube Insulation)	MLS143812T-65	•	•						
65' x 3/8" x 65' x 5/8" Lineset (Twin-Tube Insulation)	MPLS385812T-65					•	•	•	

## Optional Parts List for Indoor (M-Series)

			Floor-mount Recessed				One-way Cassette		
			MFZ-KJ				MLZ-KP		
			MFZ-KJ09NA	MFZ-KJ12NA	MFZ-KJ15NA	MFZ-KJ18NA	MLZ-KP09NA	MLZ-KP12NA	MLZ-KP18NA
Condensate	Blue Diamond (Advanced) Mini Condensate Pump w/ Reservoir & Sensor (208/230V) [recommended]	X87-721	•	•	•	•	•	•	•
	Blue Diamond (MicroBlue) Mini Condensate Pump (110/208/230V) up to 18,000 BTU/H	X85-003	•	•	•	•	•	•	•
	Blue Diamond Alarm Extension Cable—6.5 Ft.	C13-192	•	•	•	•			
	Blue Diamond MultiTank — collection tank for use with multiple pumps	C21-014	•	•	•	•			
	Blue Diamond Sensor Extension Cable — 15 Ft.	C13-103	•	•	•	•			
	Drain Pan Level Sensor/Control	SS610E	•	•	•	•			
	Sauermann Condensate Pump	SI30-230	•	•	•	•			
Disconnect Switch	(30A/600V/UL) [fits 2" X 4" utility box] - Black	TAZ-MS303	•	•	•	•	•	•	•
	(30A/600V/UL) [fits 2" X 4" utility box] - White	TAZ-MS303W	•	•	•	•	•	•	•
Filter	Anti-allergy Enzyme Filter	MAC-408FT-E	•	•	•	•	•	•	•
Floor Mount Air Guide	Floor Mount Air Guide	MAC-760FD-E	•	•	•	•			
	Grille	MLP-444WU					•	•	•
Lineset	100' x 1/4" x 100' / 1/2" Lineset (Twin-Tube Insulation)	MLS141212T-100			•	•			•
	15' x 1/4" x 15' / 1/2" Lineset (Twin-Tube Insulation)	MLS141212T-15			•	•			•
	15' x 1/4" x 15' / 3/8" Lineset (Twin-Tube Insulation)	MLS143812T-15	•	•			•	•	
	30' x 1/4" x 30' / 1/2" Lineset (Twin-Tube Insulation)	MLS141212T-30			•	•			•
	30' x 1/4" x 30' / 3/8" Lineset (Twin-Tube Insulation)	MLS143812T-30	•	•			•	•	
	50' x 1/4" x 50' / 1/2" Lineset (Twin-Tube Insulation)	MLS141212T-50			•	•			•
	50' x 1/4" x 50' / 3/8" Lineset (Twin-Tube Insulation)	MLS143812T-50	•	•			•	•	
	65' x 1/4" x 65' / 1/2" Lineset (Twin-Tube Insulation)	MLS141212T-65			•	•			•
	65' x 1/4" x 65' / 3/8" Lineset (Twin-Tube Insulation)	MLS143812T-65	•	•			•	•	

		4-way Cassette				Ducted				Residential Multi-position AHU				
		SLZ-KF				SEZ-KD				SVZ-KP				
		SLZ-KF09NA	SLZ-KF12NA	SLZ-KF15NA	SLZ-KF18NA	SEZ-KD09NA4R1	SEZ-KD12NA4R1	SEZ-KD15NA4R1	SEZ-KD18NA4R1	SVZ-KP12NA	SVZ-KP18NA	SVZ-KP24NA	SVZ-KP30NA	SVZ-KP36NA
Bottom Return Plate	Converts low-profile ducted unit from rear to bottom	BRP1				•								
		BRP2					•	•						
		BRP3							•					
Condensate	Blue Diamond (Advanced) Mini Condensate Pump w/ Reservoir & Sensor (208/230V) [recommended]	X87-721	•	•	•	•	•	•	•	•	•	•	•	•
	Blue Diamond (MegaBlue Advanced) Condensate Pump w/ Reservoir & Sensor	X87-835										•	•	•
	Blue Diamond (MicroBlue) Mini Condensate Pump (110/208/230V) up to 18,000 BTU/H	X85-003	•	•	•	•	•	•	•	•	•			
	Blue Diamond Alarm Extension Cable—6.5 Ft.	C13-192	•	•	•	•	•	•	•					
	Blue Diamond MultiTank — collection tank for use with multiple pumps	C21-014	•	•	•	•	•	•	•					
	Blue Diamond Sensor Extension Cable — 15 Ft. Sauermann Condensate Pump	C13-103	•	•	•	•	•	•	•	•	•	•	•	•
Control Wire	20/2PR, 1PR shielded + 1PR plenum wire for Airzone, 100 ft reel	CW204252-100				•	•	•	•	•	•	•	•	•
	20/2PR, shielded + 1PR plenum wire for Airzone, 500 ft reel	CW204252-500				•	•	•	•	•	•	•	•	•
Disconnect Switch	(30A/600V/UL) [fits 2" X 4" utility box] - Black	TAZ-MS303	•	•	•	•	•	•	•	•	•	•	•	•
	(30A/600V/UL) [fits 2" X 4" utility box] - White	TAZ-MS303W	•	•	•	•	•	•	•	•	•	•	•	•
Downflow Kit	Downflow Kit	DFK-M											•	•
		DFK-S								•	•	•		
Electric Heat Lockout	Electric Heat Lockout	ETC-211000-MIT								•	•	•	•	•
Electric Kit Heats	10kW Electric Heater	EH10-SVZ-M											•	•
	3kW Electric Heater	EH03-SVZ-S								•	•	•		
	5kW Electric Heater	EH05-SVZ-M											•	•
		EH05-SVZ-S									•	•	•	
8kW Electric Heater	EH08-SVZ-M											•	•	
Filter Box	Filter Box with MERV 8 Filter	FBL1-1				•								
		FBL1-2					•	•						
		FBL1-3							•					
Grille	Grille	SLP-18FAU	•	•	•	•								
		PAC-SF1ME-E	•	•	•	•								
i-see Sensor® Panel	Grille with 3D i-see Sensor®	SLP-18FAEU	•	•	•	•								
Lineset	10' x 3/8" x 10' x 5/8" Lineset (Twin-Tube Insulation)	MPLS385812T-10										•	•	•
	100' x 1/4" x 100' / 1/2" Lineset (Twin-Tube Insulation)	MLS141212T-100			•	•		•	•		•			
	100' x 3/8" x 100' x 5/8" Lineset (Twin-Tube Insulation)	MPLS385812T-100										•	•	•
	15' x 1/4" x 15' / 1/2" Lineset (Twin-Tube Insulation)	MLS141212T-15			•	•		•	•		•			
	15' x 1/4" x 15' / 3/8" Lineset (Twin-Tube Insulation)	MLS143812T-15	•	•			•	•		•				
	15' x 3/8" x 15' x 5/8" Lineset (Twin-Tube Insulation)	MPLS385812T-15										•	•	•
	30' x 1/4" x 30' / 1/2" Lineset (Twin-Tube Insulation)	MLS141212T-30			•	•		•	•		•			
	30' x 1/4" x 30' / 3/8" Lineset (Twin-Tube Insulation)	MLS143812T-30	•	•			•	•		•				
	30' x 3/8" x 30' x 5/8" Lineset (Twin-Tube Insulation)	MPLS385812T-30										•	•	•
	50' x 1/4" x 50' / 1/2" Lineset (Twin-Tube Insulation)	MLS141212T-50			•	•		•	•		•			
	50' x 1/4" x 50' / 3/8" Lineset (Twin-Tube Insulation)	MLS143812T-50	•	•			•	•		•				
	50' x 3/8" x 50' x 5/8" Lineset (Twin-Tube Insulation)	MPLS385812T-50										•	•	•
	65' x 1/4" x 65' / 1/2" Lineset (Twin-Tube Insulation)	MLS141212T-65			•	•		•	•		•			
	65' x 1/4" x 65' / 3/8" Lineset (Twin-Tube Insulation)	MLS143812T-65	•	•			•	•		•				
	65' x 3/8" x 65' x 5/8" Lineset (Twin-Tube Insulation)	MPLS385812T-65										•	•	•
Terminal Block	Separate Terminal Power Block	SPTB1								•	•	•	•	•

# Optional Parts List for Indoor (P-Series)

			Wall Mount					Ceiling Suspended			
			PKA					PCA			
			PKA-A12HA7	PKA-A18HA7	PKA-A24KA7	PKA-A30KA7	PKA-A36KA7	PCA-A24KA7	PCA-A30KA7	PCA-A36KA7	PCA-A42KA7
Condensate	Blue Diamond (Advanced) Mini Condensate Pump w/ Reservoir & Sensor (208/230V) [recommended]	X87-721	•	•	•	•	•	•	•	•	•
	Blue Diamond (MegaBlue Advanced) Condensate Pump w/ Reservoir & Sensor	X87-835			•	•	•	•	•	•	•
	Blue Diamond (MicroBlue) Mini Condensate Pump (110/208/230V) up to 18,000 BTU/H	X85-003	•	•							
	Blue Diamond Sensor Extension Cable — 15 Ft.	C13-103	•	•	•	•	•	•	•	•	•
	Drain Pan Level Sensor/Control	SS610E	•	•	•	•	•				
	Fascia Kit for MicroBlue Pump, mounts the MicroBlue and sensor directly beneath indoor unit	T18-016	•	•							
Disconnect Switch	Sauermann Condensate Pump	SI30-230	•	•	•	•	•				
	(30A/600V/UL) [fits 2" X 4" utility box] - Black	TAZ-MS303	•	•	•	•	•	•	•	•	•
Drain Pump	(30A/600V/UL) [fits 2" X 4" utility box] - White	TAZ-MS303W	•	•	•	•	•	•	•	•	•
	Drain Pump Kit	PAC-SH84DM-E						•	•	•	•
Filter	External Drain Pump	PAC-SH94DM-E			•	•	•				
	65% Medium Efficiency Filter (MERV 8)	PAC-SH89KF-E						•			
	High Efficiency (MERV 8) Filter Element	PAC-SH90KF-E						•	•	•	•
i-see Sensor® Panel	i-see Sensor®	PAC-SH91MK-E								•	
Lineset	10' x 3/8" x 10' x 5/8" Lineset (Twin-Tube Insulation)	MPLS385812T-10			•	•	•	•	•	•	•
	100' x 1/4" x 100' / 1/2" Lineset (Twin-Tube Insulation)	MLS141212T-100	•	•							
	100' x 3/8" x 100' x 5/8" Lineset (Twin-Tube Insulation)	MPLS385812T-100			•	•	•	•	•	•	•
	15' x 1/4" x 15' / 1/2" Lineset (Twin-Tube Insulation)	MLS141212T-15	•	•							
	15' x 3/8" x 15' x 5/8" Lineset (Twin-Tube Insulation)	MPLS385812T-15			•	•	•	•	•	•	•
	30' x 1/4" x 30' / 1/2" Lineset (Twin-Tube Insulation)	MLS141212T-30	•	•							
	30' x 3/8" x 30' x 5/8" Lineset (Twin-Tube Insulation)	MPLS385812T-30			•	•	•	•	•	•	•
	50' x 1/4" x 50' / 1/2" Lineset (Twin-Tube Insulation)	MLS141212T-50	•	•							
	50' x 3/8" x 50' x 5/8" Lineset (Twin-Tube Insulation)	MPLS385812T-50			•	•	•	•	•	•	•
	65' x 1/4" x 65' / 1/2" Lineset (Twin-Tube Insulation)	MLS141212T-65	•	•							
65' x 3/8" x 65' x 5/8" Lineset (Twin-Tube Insulation)	MPLS385812T-65			•	•	•	•	•	•	•	

			4-way Cassette						Residential Multi-position AHU				
			PLA						PVA				
			PLA-A12EA7	PLA-A18EA7	PLA-A24EA7	PLA-A30EA7	PLA-A36EA7	PLA-A42EA7	PVA-A12AA7	PVA-A18AA7	PVA-A24AA7	PVA-A30AA7	PVA-A42AA7
Casement	Multi-function Casement	PAC-SJ41TM-E	•	•	•	•	•	•					
Condensate	Blue Diamond (Advanced) Mini Condensate Pump w/ Reservoir & Sensor (208/230V) [recommended]	X87-721	•	•	•	•	•	•					
	Blue Diamond (MegaBlue Advanced) Condensate Pump w/ Reservoir & Sensor	X87-835			•	•	•	•					
	Blue Diamond (MicroBlue) Mini Condensate Pump (110/208/230V) up to 18,000 BTU/H	X85-003	•	•									
	Blue Diamond Sensor Extension Cable — 15 Ft.	C13-103	•	•	•	•	•	•	•	•	•	•	•
Control Wire	20/2PR, 1PR shielded + 1PR plenum wire for Airzone, 100 ft reel	CW204252-100							•	•	•	•	•
	20/2PR, shielded + 1PR plenum wire for Airzone, 500 ft reel	CW204252-500							•	•	•	•	•
Disconnect Switch	(30A/600V/UL) [fits 2" X 4" utility box] - Black	TAZ-MS303	•	•	•	•	•	•	•	•	•	•	•
	(30A/600V/UL) [fits 2" X 4" utility box] - White	TAZ-MS303W	•	•	•	•	•	•	•	•	•	•	•
Downflow Kit	Condensate Management Kit for downflow installation	CMA-1							•	•	•	•	•
Electric Heat Lockout	Electric Heat Lockout	ETC-211000-MIT							•	•	•	•	•
Electric Kit Heats	10kW Electric Heater	EH10-MPA-LB										•	•
		EH10-MPA-MB									•		
	15kW Electric Heater	EH15-MPAS-LB										•	•
	17kW Electric Heater	EH17-MPAS-LB											•
	3kW Electric Heater	EH03-MPA-MB									•		
		EH03-MPA-SB							•	•			
		EH05-MPA-MB							•	•			
	EH05-MPA-SB							•	•				
	5kW Electric Heater Module-Medium Cabinet	EH05-MPA-M								•			
	8kW Electric Heater	EH08-MPA-MB									•	•	
		EH08-MPA-SB								•			
Filter	High Efficiency Filter Element	PAC-SH59KF-E	•	•	•	•	•	•					
i-see Sensor® Panel	Grille with 3D i-see Sensor®	PLP-41EAEU	•	•	•	•	•	•					
Lineset	10' x 3/8" x 10' x 5/8" Lineset (Twin-Tube Insulation)	MPLS385812T-10			•	•	•	•			•	•	•
	100' x 1/4" x 100' / 1/2" Lineset (Twin-Tube Insulation)	MLS141212T-100	•	•					•	•			
	100' x 3/8" x 100' x 5/8" Lineset (Twin-Tube Insulation)	MPLS385812T-100			•	•	•	•			•	•	•
	15' x 1/4" x 15' / 1/2" Lineset (Twin-Tube Insulation)	MLS141212T-15	•	•					•	•			
	15' x 3/8" x 15' x 5/8" Lineset (Twin-Tube Insulation)	MPLS385812T-15			•	•	•	•			•	•	•
	30' x 1/4" x 30' / 1/2" Lineset (Twin-Tube Insulation)	MLS141212T-30	•	•					•	•			
	30' x 3/8" x 30' x 5/8" Lineset (Twin-Tube Insulation)	MPLS385812T-30			•	•	•	•			•	•	•
	50' x 1/4" x 50' / 1/2" Lineset (Twin-Tube Insulation)	MLS141212T-50	•	•					•	•			
	50' x 3/8" x 50' x 5/8" Lineset (Twin-Tube Insulation)	MPLS385812T-50			•	•	•	•			•	•	•
	65' x 1/4" x 65' / 1/2" Lineset (Twin-Tube Insulation)	MLS141212T-65	•	•					•	•			
	65' x 3/8" x 65' x 5/8" Lineset (Twin-Tube Insulation)	MPLS385812T-65			•	•	•	•			•	•	•
Shutter Plate	Drain Pan	PAC-SJ37SP-E	•	•	•	•	•	•					
Space Panel	Architectural Surround for Ceiling Recessed Units	PLFY-ITP1	•	•	•	•	•	•					
	Space Panel	PAC-SJ38AS-E	•	•	•	•	•	•					
Terminal Block	Separate Terminal Power Block	SPTB1							•	•	•	•	•

# Optional Parts List for Indoor (P-Series)

			Ducted							
			PEAD							
			PEAD-A09AA7	PEAD-A12AA7	PEAD-A15AA7	PEAD-A18AA7	PEAD-A24AA7	PEAD-A30AA7	PEAD-A36AA7	PEAD-A42AA7
Condensate	Blue Diamond (Advanced) Mini Condensate Pump w/ Reservoir & Sensor (208/230V) [recommended]	X87-721	•	•	•	•	•	•	•	•
	Blue Diamond (MegaBlue Advanced) Condensate Pump w/ Reservoir & Sensor	X87-835	•	•	•	•	•	•	•	•
	Blue Diamond Sensor Extension Cable — 15 Ft.	C13-103	•	•	•	•	•	•	•	•
Control Wire	20/2PR, 1PR shielded + 1PR plenum wire for Airzone, 100 ft reel	CW2042S2-100	•	•	•	•	•	•	•	•
	20/2PR, shielded + 1PR plenum wire for Airzone, 500 ft reel	CW2042S2-500	•	•	•	•	•	•	•	•
Disconnect Switch	(30A/600V/UL) [fits 2" X 4" utility box] - Black	TAZ-MS303	•	•	•	•	•	•	•	•
	(30A/600V/UL) [fits 2" X 4" utility box] - White	TAZ-MS303W	•	•	•	•	•	•	•	•
Filter Box	Filter Box with MERV 13 Filter	FBM2-2-A	•	•	•	•				
		FBM2-3-A					•	•		
		FBM2-4-A							•	•
Lineset	10' x 3/8" x 10' x 5/8" Lineset (Twin-Tube Insulation)	MPLS385812T-10					•	•	•	•
	100' x 1/4" x 100' / 1/2" Lineset (Twin-Tube Insulation)	MLS141212T-100		•	•	•				
	100' x 3/8" x 100' x 5/8" Lineset (Twin-Tube Insulation)	MPLS385812T-100					•	•	•	•
	15' x 1/4" x 15' / 1/2" Lineset (Twin-Tube Insulation)	MLS141212T-15		•	•	•				
	15' x 1/4" x 15' / 3/8" Lineset (Twin-Tube Insulation)	MLS143812T-15	•							
	15' x 3/8" x 15' x 5/8" Lineset (Twin-Tube Insulation)	MPLS385812T-15					•	•	•	•
	30' x 1/4" x 30' / 1/2" Lineset (Twin-Tube Insulation)	MLS141212T-30		•	•	•				
	30' x 1/4" x 30' / 3/8" Lineset (Twin-Tube Insulation)	MLS143812T-30	•							
	30' x 3/8" x 30' x 5/8" Lineset (Twin-Tube Insulation)	MPLS385812T-30					•	•	•	•
	50' x 1/4" x 50' / 1/2" Lineset (Twin-Tube Insulation)	MLS141212T-50		•	•	•				
	50' x 1/4" x 50' / 3/8" Lineset (Twin-Tube Insulation)	MLS143812T-50	•							
	50' x 3/8" x 50' x 5/8" Lineset (Twin-Tube Insulation)	MPLS385812T-50					•	•	•	•
	65' x 1/4" x 65' / 1/2" Lineset (Twin-Tube Insulation)	MLS141212T-65		•	•	•				
	65' x 1/4" x 65' / 3/8" Lineset (Twin-Tube Insulation)	MLS143812T-65	•							
	65' x 3/8" x 65' x 5/8" Lineset (Twin-Tube Insulation)	MPLS385812T-65					•	•	•	•



# Optional Parts List for Outdoor (M-Series)

			MUZ-FS									
			MUZ-FS06NA	MUZ-FS09NA	MUZ-FS12NA	MUZ-FS15NA	MUZ-FS18NA	MUZ-FS06NAH	MUZ-FS09NAH	MUZ-FS12NAH	MUZ-FS15NAH	MUZ-FS18NAH
Air Outlet Guide	Air Outlet Guide	MAC-881SG	•	•	•			•	•	•		
	M- & P-Series Maintenance Tool Cable Set	M21EC0397	•	•	•	•	•					
Control/Service Tool	USB/UART Conversion Cable (Required for all laptop connection)	M21EC1397	•	•	•	•	•					
Drain Socket	Drain Socket	MAC-811DS MAC-871DS	•	•	•	•	•				•	•
Hail Guards	Hail Guard	HG-A7 HG-B4	•	•	•		•				•	•
Mini-Split Wire	14 Gauge, 4 wire MiniSplit Cable—250 ft. roll	S144-250	•	•	•	•	•	•	•	•	•	•
	14 Gauge, 4 wire MiniSplit Cable—50 ft. roll	S144-50	•	•	•	•	•	•	•	•	•	•
	16 Gauge, 4 wire MiniSplit Cable—250 ft. roll	S164-250	•	•	•	•	•	•	•	•	•	•
	16 Gauge, 4 wire MiniSplit Cable—50 ft. roll	S164-50	•	•	•	•	•	•	•	•	•	•
Mounting Pad	Condensing Unit Mounting Pad: 16" x 36" x 3"	ULTRILITE1	•	•	•	•	•	•	•	•	•	•
	Outdoor Unit 3-1/4 inch Mounting Base (Pair) - Plastic	DSD-400P	•	•	•	•	•	•	•	•	•	•
Optional Defrost Heater	Base Heater	MAC-642BH-U1				•	•					
	Optional Defrost Heater	MAC-640BH-U	•	•	•							
Stand	18" Single Fan Stand	QSMS1801M	•	•	•	•	•	•	•	•	•	•
	24" Single Fan Stand	QSMS2401M	•	•	•	•	•	•	•	•	•	•
	Condenser Wall Bracket	QSWB2000M-1	•	•	•	•	•	•	•	•	•	•
	Condenser Wall Bracket -Stainless Steel Finish	QSWBSS	•	•	•	•	•	•	•	•	•	•
	Outdoor Unit Stand — 12" High	QSMS1201M	•	•	•	•	•	•	•	•	•	•

			MUZ-GL					MUZ-D		MUZ-HM				
			MUZ-GL09NA	MUZ-GL12NA	MUZ-GL15NA	MUZ-GL18NA	MUZ-GL24NA	MUZ-D30NA	MUZ-D36NA	MUZ-HM09NA	MUZ-HM12NA	MUZ-HM15NA	MUZ-HM18NA	MUZ-HM24NA
Air Outlet Guide	Air Outlet Guide	MAC-881SG MAC-8865G-E	•	•	•				•	•	•	•	•	
	M- & P-Series Maintenance Tool Cable Set	M21EC0397	•	•	•	•	•	•	•	•	•	•	•	
Control/Service Tool	USB/UART Conversion Cable (Required for all laptop connection)	M21EC1397	•	•	•	•	•	•	•	•	•	•	•	
Controller Holder	Remote Controller Holder	U01A01083								•				
Drain Socket	Drain Socket	MAC-811DS MAC-871DS	•	•	•	•	•	•		•	•	•	•	
Hail Guards	Hail Guard	HG-A7 HG-B4	•	•	•	•	•			•	•	•	•	
Mini-Split Wire	14 Gauge, 4 wire MiniSplit Cable—250 ft. roll	S144-250	•	•	•	•	•	•	•	•	•	•	•	
	14 Gauge, 4 wire MiniSplit Cable—50 ft. roll	S144-50	•	•	•	•	•	•	•	•	•	•	•	
	16 Gauge, 4 wire MiniSplit Cable—250 ft. roll	S164-250	•	•	•	•	•	•	•	•	•	•	•	
	16 Gauge, 4 wire MiniSplit Cable—50 ft. roll	S164-50	•	•	•	•	•	•	•	•	•	•	•	
Mounting Pad	Condensing Unit Mounting Pad: 16" x 36" x 3"	ULTRILITE1	•	•	•	•	•	•	•	•	•	•	•	
	Outdoor Unit 3-1/4 inch Mounting Base (Pair) - Plastic	DSD-400P	•	•	•	•	•	•	•	•	•	•	•	
Optional Defrost Heater	Base Heater	MAC-642BH-U1				•	•						•	
	Optional Defrost Heater	MAC-640BH-U	•	•	•				•	•	•			
Power Supplies And Auxiliary Components	M-Net Control Wire, 250' Roll (16-AWG, Standard, Twisted Pair, Shielded, Jacketed- Plenum rated)	CW1625-250					•							
Stand	18" Single Fan Stand	QSMS1801M	•	•	•	•	•	•	•	•	•	•	•	
	24" Single Fan Stand	QSMS2401M	•	•	•	•	•	•	•	•	•	•	•	
	Condenser Wall Bracket	QSWB2000M-1	•	•	•	•	•	•	•	•	•	•	•	
	Condenser Wall Bracket -Stainless Steel Finish	QSWBSS	•	•	•	•	•	•	•	•	•	•	•	
	Outdoor Unit Stand — 12" High	QSMS1201M	•	•	•	•	•	•	•	•	•	•	•	



			MUY-GL					MUY-D		MUFZ-KJ			
			MUY-GL09NA	MUY-GL12NA	MUY-GL15NA	MUY-GL18NA	MUY-GL24NA	MUY-D30NA	MUY-D36NA	MUFZ-KJ09NAHZ	MUFZ-KJ12NAHZ	MUFZ-KJ15NAHZ	MUFZ-KJ18NAHZ
Air Outlet Guide	Air Outlet Guide	MAC-881SG	•	•	•					•	•		
		MAC-886SG-E			•	•	•			•	•	•	•
Control/Service Tool	M- & P-Series Maintenance Tool Cable Set	M21EC0397	•	•	•	•	•	•	•	•	•	•	•
	USB/UART Conversion Cable (Required for all laptop connection)	M21EC1397	•	•	•	•	•	•	•	•	•	•	•
Drain Socket	Drain Socket	MAC-811DS						•	•				
		MAC-871DS	•	•	•	•	•						
Hail Guards	Hail Guard	HG-A7			•	•	•			•		•	•
		HG-B4	•	•	•					•	•		
Mini-Split Wire	14 Gauge, 4 wire MiniSplit Cable—250 ft. roll	S144-250	•	•	•	•	•	•	•	•	•	•	•
	14 Gauge, 4 wire MiniSplit Cable—50 ft. roll	S144-50	•	•	•	•	•	•	•	•	•	•	•
	16 Gauge, 4 wire MiniSplit Cable—250 ft. roll	S164-250	•	•	•	•	•	•	•	•	•	•	•
	16 Gauge, 4 wire MiniSplit Cable—50 ft. roll	S164-50	•	•	•	•	•	•	•	•	•	•	•
Mounting Pad	Condensing Unit Mounting Pad: 16" x 36" x 3"	ULTRILITE1	•	•	•	•	•	•	•	•	•	•	•
	Outdoor Unit 3-1/4 inch Mounting Base (Pair) - Plastic	DSD-400P	•	•	•	•	•	•	•	•	•	•	•
Stand	18" Single Fan Stand	QSMS1801M	•	•	•	•	•	•	•	•	•	•	•
	24" Single Fan Stand	QSMS2401M	•	•	•	•	•	•	•	•	•	•	•
	Condenser Wall Bracket	QSWB2000M-1	•	•	•	•	•	•	•	•	•	•	•
	Condenser Wall Bracket -Stainless Steel Finish	QSWB55	•	•	•	•	•	•	•	•	•	•	•
	Outdoor Unit Stand — 12" High	QSMS1201M	•	•	•	•	•	•	•	•	•	•	•

			MUZ-WR					MUZ-JP		
			MUZ-WR09NA	MUZ-WR09NA-U2	MUZ-WR12NA	MUZ-WR12NA-U2	MUZ-WR18NA-U2	MUZ-WR24NA	MUZ-JP09WA	MUZ-JP12WA
Air Outlet Guide	Air Outlet Guide	MAC-881SG	•	•	•	•	•		•	•
		MAC-886SG-E					•			
Control/Service Tool	M- & P-Series Maintenance Tool Cable Set	M21EC0397		•		•	•	•	•	•
	USB/UART Conversion Cable (Required for all laptop connection)	M21EC1397		•		•	•	•	•	•
Drain Socket	Drain Socket	MAC-871DS	•	•	•	•	•		•	•
Hail Guards	Hail Guard	HG-A7					•			
		HG-B4	•	•	•	•	•		•	•
Mini-Split Wire	14 Gauge, 4 wire MiniSplit Cable—250 ft. roll	S144-250	•	•	•	•	•	•	•	•
	14 Gauge, 4 wire MiniSplit Cable—50 ft. roll	S144-50		•		•	•	•	•	•
	16 Gauge, 4 wire MiniSplit Cable—250 ft. roll	S164-250		•		•	•	•	•	•
	16 Gauge, 4 wire MiniSplit Cable—50 ft. roll	S164-50		•		•	•	•	•	•
Mounting Pad	Condensing Unit Mounting Pad: 16" x 36" x 3"	ULTRILITE1	•	•	•	•	•	•	•	•
	Outdoor Unit 3-1/4 inch Mounting Base (Pair) - Plastic	DSD-400P	•	•	•	•	•		•	•
Optional Defrost Heater	Base Heater	MAC-642BH-U1					•			
	Optional Defrost Heater	MAC-640BH-U	•	•	•	•	•			
Stand	18" Single Fan Stand	QSMS1801M	•	•	•	•	•		•	•
	24" Single Fan Stand	QSMS2401M	•	•	•	•	•		•	•
	Condenser Wall Bracket	QSWB2000M-1	•	•	•	•	•		•	•
	Condenser Wall Bracket -Stainless Steel Finish	QSWB55	•	•	•	•	•		•	•
	Outdoor Unit Stand — 12" High	QSMS1201M	•	•	•	•	•		•	•

# Optional Parts List for Outdoor (M-Series)

			MXZ-													
			MXZ-2C20NA2	MXZ-3C24NA2	MXZ-3C30NA2	MXZ-4C36NA2	MXZ-5C42NA2	MXZ-8C48NA2-U1	MXZ-8C60NA2-U1	MXZ-2C20NAHZ2	MXZ-3C24NAHZ2	MXZ-3C30NAHZ2	MXZ-4C36NAHZ2-U1	MXZ-5C42NAHZ2-U1	MXZ-8C48NAHZ2-U1	
Air Outlet Guide	Air Outlet Guide	MAC-856SG PAC-SJ075G-E	•						•							
	Air Outlet Guide (1 Piece)	PAC-SH965G-E		•	•		•	•	•	•	•	•	•	•	•	
Ball Valve	Refrigeration Ball Valve - 1/2"	BV12FFSI2	•	•	•	•	•	•	•	•	•	•	•	•	•	
	Refrigeration Ball Valve - 1/4"	BV14FFSI2	•	•	•	•	•	•	•	•	•	•	•	•	•	
	Refrigeration Ball Valve - 3/8"	BV38FFSI2	•	•	•	•	•	•	•	•	•	•	•	•	•	
	Refrigeration Ball Valve - 5/8"	BV58FFSI2	•	•	•	•	•	•	•	•	•	•	•	•	•	
Branch Box	Branch Box	PAC-MKA32BC PAC-MKA52BC						•	•				•	•	•	
	Branch Box Enclosure	BBE-1						•	•				•	•	•	
Centralized Drain Pan	Drain Pan	PAC-SH97DP-E				•		•	•				•	•	•	
Control/Service Tool	M- & P-Series Maintenance Tool Cable Set	M21EC0397						•	•				•	•	•	
	Maintenance Tool Interface	PAC-USCMS-MN-1						•	•				•	•	•	
	USB/UART Conversion Cable (Required for all laptop connection)	M21EC1397						•	•				•	•	•	
Distribution pipe for Branch Box	Brazed Connection	MSDD-50BR-E						•	•				•	•	•	
	Flare Connection	MSDD-50AR-E						•	•				•	•	•	
	M-NET Converter	PAC-IF01MNT-E	•	•	•		•			•	•	•				
Drain Socket	Drain Socket	MAC-811DS	•													
		PAC-SG60DS-E		•	•	•	•									
		PAC-SG61DS-E							•							
Hail Guards	Hail Guard	HG-A1					•			•	•	•				
		HG-A2				•		•	•				•	•	•	
		HG-A8	•													
		HG-A9		•	•											
Mini-Split Wire	14 Gauge, 4 wire MiniSplit Cable—250 ft. roll	S144-250						•	•				•	•	•	
	14 Gauge, 4 wire MiniSplit Cable—50 ft. roll	S144-50						•	•				•	•	•	
	16 Gauge, 4 wire MiniSplit Cable—250 ft. roll	S164-250						•	•				•	•	•	
	16 Gauge, 4 wire MiniSplit Cable—50 ft. roll	S164-50						•	•				•	•	•	
Mounting Pad	Condensing Unit Mounting Pad: 16" x 36" x 3"	ULTRILITE1	•	•	•		•	•	•	•	•	•	•	•	•	
	Condensing Unit Mounting Pad: 24" x 42" x 3"	ULTRILITE2	•			•							•	•		
	Outdoor Unit 3-1/4 inch Mounting Base (Pair) - Plastic	DSD-400P	•	•	•	•	•	•	•	•	•	•	•	•	•	
Optional Defrost Heater	Base Heater	PAC-646BH-E	•	•	•											
	Optional Defrost Heater	PAC-645BH-E				•	•									
		PAC-SJ20BH-E						•	•							
Port Adapter	Adaptor: 1/2" x 3/8"	MAC-A455JP-E	•	•	•	•	•	•	•	•	•	•	•	•	•	
	Adaptor: 1/2" x 5/8"	MAC-A456JP-E	•	•	•	•	•	•	•	•	•	•	•	•	•	
	Adaptor: 3/8" x 1/2"	MAC-A454JP-E	•	•	•	•	•	•	•	•	•	•	•	•	•	
	Adaptor: 3/8" x 5/8"	PAC-SG76RJ-E	•	•	•	•	•	•	•	•	•	•	•	•	•	
Power Supplies and Auxiliary Components	M-Net Control Wire, 1,000' Roll (16-AWG, Standard, Twisted Pair, Shielded, Jacketed- Plenum rated)	CW162S-1000		•	•		•			•	•	•				
Power Supplies And Auxiliary Components	M-Net Control Wire, 250' Roll (16-AWG, Standard, Twisted Pair, Shielded, Jacketed- Plenum rated)	CW162S-250		•	•		•			•	•	•				
Stand	18" Dual Fan Stand	QSMS1802M						•	•				•	•	•	
	18" Single Fan Stand	QSMS1801M	•	•	•		•			•	•	•				
	24" Dual Fan Stand	QSMS2402M				•		•	•				•	•	•	
	24" Single Fan Stand	QSMS2401M	•	•	•		•			•	•	•				
	Condenser Wall Bracket	QSWB2000M-1	•	•	•	•	•	•	•	•	•	•	•	•	•	
	Condenser Wall Bracket -Stainless Steel Finish	QSWBSS	•	•	•	•	•	•	•	•	•	•	•	•	•	
	Outdoor Unit Stand — 12" High	QSMS1201M QSMS1202M	•	•	•		•		•	•	•	•		•	•	
Wind Baffle	Front Wind Baffle	WB-PA3						•	•				•	•	•	

			SUZ-KA														
			SUZ-KA09NA2	SUZ-KA12NA2	SUZ-KA15NA2	SUZ-KA18NA2	SUZ-KA24NA2	SUZ-KA30NA2	SUZ-KA36NA2	SUZ-KA09NAHZ	SUZ-KA12NAHZ	SUZ-KA15NAHZ	SUZ-KA18NAHZ	SUZ-KA24NAHZ	SUZ-KA30NAHZ	SUZ-KA36NAHZ	
Air Outlet Guide	Air Outlet Guide	MAC-886SG-E				•	•	•	•				•				
	Air Outlet Guide (1 Piece)	PAC-SG59SG-E PAC-SH96SG-E												•		•	
Centralized Drain Pan	Drain Pan	PAC-SG64DS-E												•			
		PAC-SH97DP-E														•	•
Control/Service Tool	M- & P-Series Maintenance Tool Cable Set	M21EC0397	•	•	•	•	•	•	•	•	•	•	•	•	•	•	
	USB/UART Conversion Cable (Required for all laptop connection)	M21EC1397	•	•	•	•	•	•	•						•	•	
Drain Socket	Drain Socket	PAC-SH71DS-E												•	•	•	
Hail Guards	Hail Guard	HG-A2														•	•
		HG-A6													•		
		HG-B4	•	•	•												
Mini-Split Wire	14 Gauge, 4 wire MiniSplit Cable—250 ft. roll	S144-250	•	•	•	•	•	•	•	•	•	•	•	•		•	•
		SW144-250	•	•	•	•	•	•	•	•	•	•	•	•			
	14 Gauge, 4 wire MiniSplit Cable—50 ft. roll	S144-50	•	•	•	•	•	•	•	•	•	•	•	•		•	•
		SW144-50	•	•	•	•	•	•	•	•	•	•	•	•			
	16 Gauge, 4 wire MiniSplit Cable—250 ft. roll	S164-250	•	•	•	•	•	•	•	•	•	•	•	•		•	•
		SW164-250	•	•	•	•	•	•	•	•	•	•	•	•			
	16 Gauge, 4 wire MiniSplit Cable—50 ft. roll	S164-50	•	•	•	•	•	•	•	•	•	•	•	•		•	•
		SW164-50	•	•	•	•	•	•	•	•	•	•	•	•			
Mounting Pad	Condensing Unit Mounting Pad: 16" x 36" x 3"	ULTRILITE1	•	•	•	•	•	•	•	•	•	•	•				
	Condensing Unit Mounting Pad: 24" x 42" x 3"	ULTRILITE2													•	•	•
	Outdoor Unit 3-1/4 inch Mounting Base (Pair) - Plastic	DSD-400P	•	•	•	•	•	•	•								
Optional Defrost Heater	Base Heater	MAC-642BH-U1				•	•	•	•				•				
Port Adapter	Adaptor: 3/8" x 1/2"	MAC-A454JP-E		•							•						
Stand	18" Dual Fan Stand	QSMS1802M														•	•
	18" Single Fan Stand	QSMS1801M	•	•	•	•	•	•	•	•	•	•	•	•			
	24" Dual Fan Stand	QSMS2402M														•	•
	24" Single Fan Stand	QSMS2401M	•	•	•	•	•	•	•	•	•	•	•	•			
	Condenser Wall Bracket	QSWB2000M-1	•	•	•	•	•	•	•	•	•	•	•	•			
	Outdoor Unit Stand — 12" High	QSMS1201M QSMS1202M	•	•	•	•	•	•	•	•	•	•	•	•			•

# Optional Parts List for Outdoor (P-Series)

			PUY					
			PUY-A12NKA7(-BS)	PUY-A18NKA7(-BS)	PUY-A24NHA7(-BS)	PUY-A30NHA7(-BS)	PUY-A36NKA7(-BS)	PUY-A42NKA7(-BS)
Air Outlet Guide	Air Outlet Guide	PAC-SJ075G-E	•	•				
	Air Outlet Guide (1 Piece)	PAC-SG595G-E PAC-SH965G-E			•	•		•
Centralized Drain Pan	Centralized Drain Pan	PAC-SG63DP-E	•	•				
	Drain Pan	PAC-SG64DP-E			•	•		
Control/Service Tool	Control/Service Tool	PAC-SK52ST	•	•	•	•	•	•
	M- & P-Series Maintenance Tool Cable Set	M21EC0397	•	•	•	•	•	•
	USB/UART Conversion Cable (Required for all laptop connection)	M21EC1397	•	•	•	•	•	•
Distribution pipe	Twinning Distribution Pipe (50:50)	MSDD-50TR-E			•		•	
Drain Socket	Drain Socket	PAC-SG61DS-E			•	•	•	•
		PAC-SJ08DS-E	•	•				
Hail Guards	Hail Guard	HG-A5	•	•				
		HG-A6			•	•		
M-NET Converter	M-NET Converter	PAC-SJ85MA-E			•	•	•	•
		PAC-SJ95MA-E			•	•	•	•
		PAC-SJ96MA-E	•	•				
Mini-Split Wire	14 Gauge, 4 wire MiniSplit Cable—250 ft. roll	S144-250	•	•	•	•	•	•
	14 Gauge, 4 wire MiniSplit Cable—50 ft. roll	S144-50	•	•	•	•	•	
	16 Gauge, 4 wire MiniSplit Cable—250 ft. roll	S164-250	•	•	•	•	•	
	16 Gauge, 4 wire MiniSplit Cable—50 ft. roll	S164-50	•	•	•	•	•	
Mounting Pad	Condensing Unit Mounting Pad: 16" x 36" x 3"	ULTRILITE1	•	•				
	Condensing Unit Mounting Pad: 24" x 42" x 3"	ULTRILITE2			•	•	•	•
Stand	18" Dual Fan Stand	QSMS1802M					•	•
	18" Single Fan Stand	QSMS1801M	•	•	•	•		
	24" Dual Fan Stand	QSMS2402M					•	•
	24" Single Fan Stand	QSMS2401M	•	•	•	•		
	Condenser Wall Bracket	QSWB2000M-1	•	•	•	•	•	•
	Condenser Wall Bracket -Stainless Steel Finish	QSWB55	•	•	•	•	•	•
	Outdoor Unit Stand — 12" High	QSMS1201M QSMS1202M	•	•	•	•		
Wind Baffle	Front Wind Baffle	WB-PA3					•	•
		WB-PA4	•	•				
		WB-PA5			•	•		
	Rear Wind Baffle	WB-RE4	•	•				
		WB-RE5			•	•		
		WB-RE6					•	•
	Side Advanced Wind Baffle	WB-SD4	•	•				
		WB-SD5			•	•		
		WB-SD6					•	•

			PUZ									
			PUZ-A12NKA7(-BS)	PUZ-A18NKA7(-BS)	PUZ-A24NHA7(-BS)	PUZ-A30NHA7(-BS)	PUZ-A36NKA7(-BS)	PUZ-A42NKA7(-BS)	PUZ-HA24NHA1	PUZ-HA30NKA	PUZ-HA36NKA	PUZ-HA42NKA1
Air Outlet Guide	Air Outlet Guide	PAC-SJ075G-E	•	•								
	Air Outlet Guide (1 Piece)	PAC-SG595G-E PAC-SH965G-E			•	•	•	•	•	•	•	•
Centralized Drain Pan	Centralized Drain Pan	PAC-SG63DP-E	•	•								
	Drain Pan	PAC-SG64DP-E PAC-SH97DP-E			•	•			•			
Control/Service Tool	Control/Service Tool	PAC-SK52ST	•	•	•	•	•	•	•	•	•	•
	M- & P-Series Maintenance Tool Cable Set	M21EC0397	•	•	•	•	•	•				
	USB/UART Conversion Cable (Required for all laptop connection)	M21EC1397	•	•	•	•	•	•				
Distribution pipe	Twining Distribution Pipe (50:50)	MSDD-50TR-E			•		•					
Drain Socket	Drain Socket	PAC-SG61DS-E PAC-SJ08DS-E	•	•								
Hail Guards	Hail Guard	HG-A2									•	•
		HG-A5	•	•								
		HG-A6			•	•				•		
M-NET Converter	M-NET Converter	PAC-SJ85MA-E			•	•	•	•	•	•	•	•
		PAC-SJ95MA-E			•	•	•	•	•	•	•	•
		PAC-SJ96MA-E	•	•								
Mini-Split Wire	14 Gauge, 4 wire MiniSplit Cable—250 ft. roll	S144-250	•	•	•	•	•	•				
	14 Gauge, 4 wire MiniSplit Cable—50 ft. roll	S144-50	•	•	•	•	•	•				
	16 Gauge, 4 wire MiniSplit Cable—250 ft. roll	S164-250	•	•	•	•	•	•				
	16 Gauge, 4 wire MiniSplit Cable—50 ft. roll	S164-50	•	•	•	•	•	•				
Mounting Pad	Condensing Unit Mounting Pad: 16" x 36" x 3"	ULTRILITE1	•	•								
	Condensing Unit Mounting Pad: 24" x 42" x 3"	ULTRILITE2			•	•	•	•	•	•	•	•
Optional Defrost Heater	Optional Defrost Heater	PAC-SJ20BH-E									•	•
Stand	18" Dual Fan Stand	QSMS1802M					•	•		•	•	•
	18" Single Fan Stand	QSMS1801M	•	•	•	•			•			
	24" Dual Fan Stand	QSMS2402M					•	•		•	•	•
	24" Single Fan Stand	QSMS2401M	•	•	•	•			•			
	Condenser Wall Bracket	QSWB2000M-1	•	•	•	•	•	•	•	•	•	•
	Condenser Wall Bracket -Stainless Steel Finish	QSWB55	•	•	•	•	•	•	•	•	•	•
	Outdoor Unit Stand — 12" High	QSMS1201M QSMS1202M	•	•	•	•			•		•	•
Wind Baffle	Front Wind Baffle	WB-PA3					•	•			•	•
		WB-PA4	•	•								
		WB-PA5			•	•				•		
	Rear Wind Baffle	WB-RE4	•	•								
		WB-RE5			•	•				•		
		WB-RE6					•	•				
	Side Advanced Wind Baffle	WB-SD4	•	•								
		WB-SD5			•	•				•		
		WB-SD6					•	•				

# Optional Parts List for Controllers

			Wall Mount								
			MSZ-FS					MSZ-EF			
			MSZ-FS06NA	MSZ-FS09NA	MSZ-FS12NA	MSZ-FS15NA	MSZ-FS18NA	MSZ-EF09NA(B/5/W)	MSZ-EF12NA(B/5/W)	MSZ-EF15NA(B/5/W)	MSZ-EF18NA(B/5/W)
Control Interface	BACnet® and Modbus Interface	PAC-UKPRC001-CN-1	•	•	•	•	•	•	•	•	•
	CN24 Relay Kit	CN24RELAY-KIT-CM3	•	•	•	•	•	•	•	•	•
	IT Extender	PAC-WHS01IE-E	•	•	•	•	•	•	•	•	•
	kumo station® for kumo cloud®	PAC-WHS01HC-E	•	•	•	•	•	•	•	•	•
	Lockdown bracket for remote controller	RCMKP1CB	•	•	•	•	•	•	•	•	•
	System Control Interface	MAC-334IF-E	•	•	•	•	•	•	•	•	•
	Thermostat Interface	PAC-US444CN-1	•	•	•	•	•	•	•	•	•
	USNAP Adapter	PAC-WHS01UP-E	•	•	•	•	•	•	•	•	•
Remote Sensor	Wireless Interface for kumo cloud®	PAC-USWHS002-WF-2	•	•	•	•	•				
	Wired Remote Sensor	M21EAA307	•	•	•	•	•				
Wired Remote Controller	Wireless temperature and humidity sensor for kumo cloud®	PAC-USWHS003-TH-1	•	•	•	•	•	•	•	•	•
	Deluxe Wired MA Remote Controller†	PAR-40MAAU	•	•	•	•	•	•	•	•	•
	Simple MA Remote Controller†	PAC-YT53CRAU-J	•	•	•	•	•	•	•	•	•
Wireless Remote Controller	Touch MA Controller†	PAR-CT01MAU-SB	•	•	•	•	•	•	•	•	•
	kumo touch™ RedLINK™ Wireless Controller	MHK2	•	•	•	•	•	•	•	•	•

			Wall Mount							
			MSZ-GL					MSZ-D		
			MSZ-GL06NA	MSZ-GL09NA	MSZ-GL12NA	MSZ-GL15NA	MSZ-GL18NA	MSZ-GL24NA	MSZ-D30NA	MSZ-D36NA
Control Interface	BACnet® and Modbus Interface	PAC-UKPRC001-CN-1		•	•	•	•	•	•	•
	IT Extender	PAC-WHS01IE-E							•	•
	kumo station® for kumo cloud®	PAC-WHS01HC-E	•	•	•				•	•
	Lockdown bracket for remote controller	RCMKP1CB	•	•	•	•	•	•	•	•
	System Control Interface	MAC-334IF-E	•	•	•	•	•	•	•	•
	Thermostat Interface	PAC-US444CN-1							•	•
	USNAP Adapter	PAC-WHS01UP-E							•	•
	Wireless Interface for kumo cloud®	PAC-USWHS002-WF-2	•		•	•	•	•	•	•
Remote Sensor	Wired Remote Sensor	M21EAA307	•		•	•			•	•
	Wireless temperature and humidity sensor for kumo cloud®	PAC-USWHS003-TH-1	•	•	•	•	•	•	•	•
Wired Remote Controller	Deluxe Wired MA Remote Controller†	PAR-40MAAU	•	•	•	•	•	•	•	•
	Simple MA Remote Controller†	PAC-YT53CRAU-J	•	•	•	•	•	•	•	•
	Touch MA Controller†	PAR-CT01MAU-SB	•	•	•	•	•	•	•	•
Wireless Remote Controller	kumo touch™ RedLINK™ Wireless Controller	MHK2	•	•	•	•	•	•	•	

			Wall Mount										
			MSZ-HM					MSZ-JP		MSZ-WR			
			MSZ-HM09NA	MSZ-HM12NA	MSZ-HM15NA	MSZ-HM18NA	MSZ-HM24NA	MSZ-JP09WA	MSZ-JP12WA	MSZ-WR09NA	MSZ-WR12NA	MSZ-WR18NA	MSZ-WR24NA
Control Interface	BACnet® and Modbus Interface	PAC-UKPRC001-CN-1	•	•	•	•	•	•	•	•	•	•	•
	IT Extender	PAC-WHS01IE-E	•	•	•	•	•	•	•	•	•	•	•
	kumo station® for kumo cloud®	PAC-WHS01HC-E	•	•	•	•	•	•	•	•	•	•	•
	Lockdown bracket for remote controller	RCMKP1CB	•	•	•	•	•			•	•	•	•
	System Control Interface	MAC-334IF-E	•	•	•	•	•	•	•	•	•	•	•
	Thermostat Interface	PAC-US444CN-1	•	•	•	•	•	•	•	•	•	•	•
	USNAP Adapter	PAC-WHS01UP-E	•	•	•	•	•	•	•	•	•	•	•
Remote Sensor	Wireless Interface for kumo cloud®	PAC-USWHS002-WF-2	•	•	•	•	•	•	•	•	•	•	•
	Wired Remote Sensor	M21EAA307	•	•	•			•	•	•	•		
Wired Remote Controller	Wireless temperature and humidity sensor for kumo cloud®	PAC-USWHS003-TH-1	•	•	•	•	•	•	•	•	•	•	•
	Deluxe Wired MA Remote Controller†	PAR-40MAAU	•	•	•	•	•	•	•	•	•	•	•
	Simple MA Remote Controller†	PAC-YT53CRAU-J	•	•	•	•	•	•	•	•	•	•	•
Wireless Remote Controller	Touch MA Controller†	PAR-CT01MAU-SB	•	•	•	•	•	•	•	•	•	•	•
	kumo touch™ RedLINK™ Wireless Controller	MHK2	•	•	•	•	•	•	•	•	•	•	•

			Wall Mount						
			MSY-GL				MSY-D		
			MSY-GL09NA	MSY-GL12NA	MSY-GL15NA	MSY-GL18NA	MSY-GL24NA	MSY-D30NA	MSY-D36NA
Control Interface	BACnet® and Modbus Interface	PAC-UKPRC001-CN-1	•	•	•	•	•	•	•
	IT Extender	PAC-WHS01IE-E						•	•
	kumo station® for kumo cloud®	PAC-WHS01HC-E	•	•				•	•
	Lockdown bracket for remote controller	RCMKP1CB	•	•	•	•	•		•
	System Control Interface	MAC-334IF-E	•	•	•	•	•		•
	Thermostat Interface	PAC-US444CN-1						•	•
	USNAP Adapter	PAC-WHS01UP-E						•	•
Remote Sensor	Wireless Interface for kumo cloud®	PAC-USWHS002-WF-2	•	•	•	•	•	•	•
	Wired Remote Sensor	M21EAA307	•	•	•	•		•	•
Wired Remote Controller	Wireless temperature and humidity sensor for kumo cloud®	PAC-USWHS003-TH-1	•	•	•	•	•	•	•
	Deluxe Wired MA Remote Controller†	PAR-40MAAU	•	•	•	•	•	•	•
	Simple MA Remote Controller†	PAC-YT53CRAU-J	•	•	•	•	•	•	•
Wireless Remote Controller	Touch MA Controller†	PAR-CT01MAU-SB	•	•	•	•	•	•	•
	kumo touch™ RedLINK™ Wireless Controller	MHK2	•	•	•	•	•	•	•

			Floor-mount Recessed				One-way Cassette		
			MFZ-KJ				MLZ-KP		
			MFZ-KJ09NA	MFZ-KJ12NA	MFZ-KJ15NA	MFZ-KJ18NA	MLZ-KP09NA	MLZ-KP12NA	MLZ-KP18NA
Control Interface	BACnet® and Modbus Interface	PAC-UKPRC001-CN-1	•	•	•	•	•	•	•
	CN24 Relay Kit	CN24RELAY-KIT-CM3	•	•	•	•	•	•	•
	IT Extender	PAC-WHS01IE-E	•	•	•	•	•	•	•
	kumo station® for kumo cloud®	PAC-WHS01HC-E	•	•	•	•	•	•	•
	Lockdown bracket for remote controller	RCMKP1CB	•	•	•	•	•	•	•
	System Control Interface	MAC-334IF-E	•	•	•	•	•	•	•
	Thermostat Interface	PAC-US444CN-1	•	•	•	•	•	•	•
	USNAP Adapter	PAC-WHS01UP-E	•	•	•	•	•	•	•
	Wireless Interface for kumo cloud®	PAC-USWHS002-WF-2	•	•	•	•	•	•	•
Remote Sensor	Flush Mount Temperature Sensor	PAC-USSEN001-FM-1					•	•	•
	Wired Remote Sensor	M21EAA307	•	•	•	•	•	•	•
Wired Remote Controller	Wireless temperature and humidity sensor for kumo cloud®	PAC-USWHS003-TH-1	•	•	•	•	•	•	•
	Deluxe Wired MA Remote Controller†	PAR-40MAAU	•	•	•	•	•	•	•
	Simple MA Remote Controller†	PAC-YT53CRAU-J	•	•	•	•	•	•	•
Wireless Remote Controller	Touch MA Controller†	PAR-CT01MAU-SB	•	•	•	•	•	•	•
	kumo touch™ RedLINK™ Wireless Controller	MHK2	•	•	•	•	•	•	•

# Optional Parts List for Controllers

			4-way Cassette				Ducted				Residential Multi-position AHU				
			SLZ-KF				SEZ-KD				SVZ-KP				
			SLZ-KF09NA	SLZ-KF12NA	SLZ-KF15NA	SLZ-KF18NA	SEZ-KD09NA4R1	SEZ-KD12NA4R1	SEZ-KD15NA4R1	SEZ-KD18NA4R1	SVZ-KP12NA	SVZ-KP18NA	SVZ-KP24NA	SVZ-KP30NA	SVZ-KP36NA
Control Interface	3-Pin Connector	PAC-715AD	•	•	•	•	•	•	•	•	•	•	•	•	
	BACnet® and Modbus Interface	PAC-UKPRC001-CN-1	•	•	•	•	•	•	•	•	•	•	•	•	
	CN24 Relay Kit	CN24RELAY-KIT-CM3	•	•	•	•	•	•	•	•	•	•	•	•	
	Connector and wire for Operation status/error using CN51	PAC-725AD	•	•	•	•	•	•	•	•	•	•	•	•	
	Connector cable for remote display	PAC-SA88HA-EP	•	•	•	•	•	•	•	•	•	•	•	•	
	IT Extender	PAC-WHS01IE-E	•	•	•	•	•	•	•	•	•	•	•	•	
	kumo station® for kumo cloud®	PAC-WHS01HC-E	•	•	•	•	•	•	•	•	•	•	•	•	
	Lockdown bracket for remote controller	RCMKP1CB	•	•	•	•	•	•	•	•	•	•	•	•	
	Remote Operation Adapter†	PAC-SF40RM-E	•	•	•	•	•	•	•	•	•	•	•	•	
	Thermostat Interface	PAC-US444CN-1	•	•	•	•	•	•	•	•	•	•	•	•	
	USNAP Adapter	PAC-WHS01UP-E	•	•	•	•	•	•	•	•	•	•	•	•	
	Wireless Interface for kumo cloud®	PAC-USWHS002-WF-2	•	•	•	•	•	•	•	•	•	•	•	•	
Remote Sensor	Flush Mount Temperature Sensor	PAC-USSEN001-FM-1	•	•	•	•	•	•	•	•	•	•	•	•	
	Remote Temperature Sensor surface mount	PAC-SE41TS-E	•	•	•	•	•	•	•	•	•	•	•	•	
	Wireless temperature and humidity sensor for kumo cloud®	PAC-USWHS003-TH-1	•	•	•	•	•	•	•	•	•	•	•	•	
Wired Remote Controller	Airzone ZBS Wired Blueface Principal Controller White	AZZB5BLUEFACECB	•	•	•	•	•	•	•	•	•	•	•	•	
	Airzone ZBS Wired Lite Controller White	AZZB5LITECB	•	•	•	•	•	•	•	•	•	•	•	•	
	Airzone ZBS Wired Think Controller White	AZZB5THINKCB	•	•	•	•	•	•	•	•	•	•	•	•	
	Airzone ZBS Wireless Lite Controller White	AZZB5LITERB	•	•	•	•	•	•	•	•	•	•	•	•	
	Airzone ZBS Wireless Think Controller White	AZZB5THINKRB	•	•	•	•	•	•	•	•	•	•	•	•	
	Deluxe Wired MA Remote Controller†	PAR-40MAAU	•	•	•	•	•	•	•	•	•	•	•	•	
	Simple MA Remote Controller†	PAC-YT53CRAU-J	•	•	•	•	•	•	•	•	•	•	•	•	
Wireless Remote Controller	Touch MA Controller†	PAR-CT01MAU-SB	•	•	•	•	•	•	•	•	•	•	•	•	
	kumo touch™ RedLINK™ Wireless Controller	MHK2	•	•	•	•	•	•	•	•	•	•	•	•	
	Wireless MA Receiver	PAR-FA32MA-W	•	•	•	•	•	•	•	•	•	•	•	•	
	Wireless MA Remote Controller	PAR-FL32MA-E	•	•	•	•	•	•	•	•	•	•	•	•	
	Wireless Receiver	PAR-SF9FA-E	•	•	•	•	•	•	•	•	•	•	•	•	
	Wireless Remote Controller	PAR-SL100A-E	•	•	•	•	•	•	•	•	•	•	•	•	
Wireless Signal Receiver	PAR-SA9CA-E	•	•	•	•	•	•	•	•	•	•	•	•		

			Wall Mount					Ceiling Suspended				
			PKA					PCA				
			PKA-A12HA7	PKA-A18HA7	PKA-A24KA7	PKA-A30KA7	PKA-A36KA7	PCA-A24KA7	PCA-A30KA7	PCA-A36KA7	PCA-A42KA7	
Control Interface	3-Pin Connector	PAC-715AD	•	•	•	•	•	•	•	•	•	
	BACnet® and Modbus Interface	PAC-UKPRC001-CN-1	•	•	•	•	•	•	•	•	•	
	CN24 Relay Kit	CN24RELAY-KIT-CM3	•	•	•	•	•	•	•	•	•	
	IT Extender	PAC-WHS01IE-E	•	•	•	•	•	•	•	•	•	
	kumo station® for kumo cloud®	PAC-WHS01HC-E	•	•	•	•	•	•	•	•	•	
	Lockdown bracket for remote controller	RCMKP1CB	•	•	•	•	•	•	•	•	•	
	Remote Operation Adapter†	PAC-SF40RM-E	•	•	•	•	•	•	•	•	•	
	Thermostat Interface	PAC-US444CN-1	•	•	•	•	•	•	•	•	•	
	USNAP Adapter	PAC-WHS01UP-E	•	•	•	•	•	•	•	•	•	
	Wireless Interface for kumo cloud®	PAC-USWHS002-WF-2	•	•	•	•	•	•	•	•	•	
	Remote Sensor	Flush Mount Temperature Sensor	PAC-USSEN001-FM-1	•	•	•	•	•	•	•	•	•
		Remote Temperature Sensor surface mount	PAC-SE41TS-E	•	•	•	•	•	•	•	•	•
Wireless temperature and humidity sensor for kumo cloud®		PAC-USWHS003-TH-1	•	•	•	•	•	•	•	•	•	
Wired Remote Controller	Deluxe Wired MA Remote Controller†	PAR-40MAAU	•	•	•	•	•	•	•	•	•	
	Simple MA Remote Controller†	PAC-YT53CRAU-J	•	•	•	•	•	•	•	•	•	
	Touch MA Controller†	PAR-CT01MAU-SB	•	•	•	•	•	•	•	•	•	
Wireless Remote Controller	kumo touch™ RedLINK™ Wireless Controller	MHK2	•	•	•	•	•	•	•	•	•	
	Wireless MA Receiver	PAR-FA32MA-W	•	•	•	•	•	•	•	•	•	
	Wireless MA Remote Controller	PAR-FL32MA-E	•	•	•	•	•	•	•	•	•	
	Wireless Receiver Kit	PAR-SL93B-E	•	•	•	•	•	•	•	•	•	
	Wireless Receiver Kit with i-See sensor™	PAR-SA92MW-E	•	•	•	•	•	•	•	•	•	



			4-way Cassette						Residential Multi-position AHU				
			PLA						PVA				
			PLA-A12EA7	PLA-A18EA7	PLA-A24EA7	PLA-A30EA7	PLA-A36EA7	PLA-A42EA7	PVA-A12AA7	PVA-A18AA7	PVA-A24AA7	PVA-A30AA7	PVA-A42AA7
Control Interface	3-Pin Connector	PAC-715AD	•	•	•	•	•	•	•	•	•	•	•
	BACnet® and Modbus Interface	PAC-UKPRC001-CN-1	•	•	•	•	•	•	•	•	•	•	•
	CN24 Relay Kit	CN24RELAY-KIT-CM3	•	•	•	•	•	•	•	•	•	•	•
	Connector cable for remote display	PAC-SA88HA-EP	•	•	•	•	•	•	•	•	•	•	•
	IT Extender	PAC-WHS01IE-E	•	•	•	•	•	•	•	•	•	•	•
	kumo station® for kumo cloud®	PAC-WHS01HC-E	•	•	•	•	•	•	•	•	•	•	•
	Lockdown bracket for remote controller	RCMKP1CB	•	•	•	•	•	•	•	•	•	•	•
	Remote Operation Adapter‡	PAC-SF40RM-E	•	•	•	•	•	•	•	•	•	•	•
	Thermostat Interface	PAC-US444CN-1	•	•	•	•	•	•	•	•	•	•	•
	USNAP Adapter	PAC-WHS01UP-E	•	•	•	•	•	•	•	•	•	•	•
Remote Sensor	Wireless Interface for kumo cloud®	PAC-USWHS002-WF-2	•	•	•	•	•	•	•	•	•	•	•
	Flush Mount Temperature Sensor	PAC-USSEN001-FM-1	•	•	•	•	•	•	•	•	•	•	•
	Remote Temperature Sensor surface mount Wireless temperature and humidity sensor for kumo cloud®	PAC-SE41TS-E PAC-USWHS003-TH-1	• •	• •	• •	• •	• •	• •	• •	• •	• •	• •	• •
Wired Remote Controller	Airzone ZBS Wired Blueface Principal Controller White	AZZB5BLUEFACECB							•	•	•	•	•
	Airzone ZBS Wired Lite Controller White	AZZB5LITECB							•	•	•	•	•
	Airzone ZBS Wired Think Controller White	AZZB5THINKCB							•	•	•	•	•
	Airzone ZBS Wireless Lite Controller White	AZZB5LITERB							•	•	•	•	•
	Airzone ZBS Wireless Think Controller White	AZZB5THINKRB							•	•	•	•	•
	Deluxe Wired MA Remote Controller†	PAR-40MAAU	•	•	•	•	•	•	•	•	•	•	•
	Simple MA Remote Controller†	PAC-YT53CRAU-J	•	•	•	•	•	•	•	•	•	•	•
	Touch MA Controller†	PAR-CT01MAU-SB	•	•	•	•	•	•	•	•	•	•	•
Wireless Remote Controller	kumo touch™ RedLINK™ Wireless Controller	MHK2	•	•	•	•	•	•	•	•	•	•	•
	Wireless MA Receiver	PAR-FA32MA-W							•	•	•	•	•
	Wireless MA Remote Controller	PAR-FL32MA-E							•	•	•	•	•
	Wireless Receiver Kit with i-See sensor™	PAR-SA92MW-E							•	•	•	•	•
	Wireless Remote Controller	PAR-SL100A-E	•	•	•	•	•	•	•	•	•	•	•
	Wireless Signal Receiver	PAR-SA9CA-E							•	•	•	•	•
	Wireless Signal Receiver Panel	PAR-SR4LU-E	•	•	•	•	•	•					

			Ducted										
			PEAD										
			PEAD-A09AA7	PEAD-A12AA7	PEAD-A15AA7	PEAD-A18AA7	PEAD-A24AA7	PEAD-A30AA7	PEAD-A36AA7	PEAD-A42AA7			
Control Interface	3-Pin Connector	PAC-715AD	•	•	•	•	•	•	•	•	•	•	•
	BACnet® and Modbus Interface	PAC-UKPRC001-CN-1	•	•	•	•	•	•	•	•	•	•	•
	CN24 Relay Kit	CN24RELAY-KIT-CM3	•	•	•	•	•	•	•	•	•	•	•
	Connector cable for remote display	PAC-SA88HA-EP	•	•	•	•	•	•	•	•	•	•	•
	IT Extender	PAC-WHS01IE-E	•	•	•	•	•	•	•	•	•	•	•
	kumo station® for kumo cloud®	PAC-WHS01HC-E	•	•	•	•	•	•	•	•	•	•	•
	Lockdown bracket for remote controller	RCMKP1CB	•	•	•	•	•	•	•	•	•	•	•
	Remote Operation Adapter‡	PAC-SF40RM-E	•	•	•	•	•	•	•	•	•	•	•
	Thermostat Interface	PAC-US444CN-1	•	•	•	•	•	•	•	•	•	•	•
	USNAP Adapter	PAC-WHS01UP-E	•	•	•	•	•	•	•	•	•	•	•
Remote Sensor	Wireless Interface for kumo cloud®	PAC-USWHS002-WF-2	•	•	•	•	•	•	•	•	•	•	•
	Flush Mount Temperature Sensor	PAC-USSEN001-FM-1	•	•	•	•	•	•	•	•	•	•	•
	Remote Temperature Sensor surface mount Wireless temperature and humidity sensor for kumo cloud®	PAC-SE41TS-E PAC-USWHS003-TH-1	• •	• •	• •	• •	• •	• •	• •	• •	• •	• •	• •
Wired Remote Controller	Airzone ZBS Wired Blueface Principal Controller White	AZZB5BLUEFACECB	•	•	•	•	•	•	•	•	•	•	•
	Airzone ZBS Wired Lite Controller White	AZZB5LITECB	•	•	•	•	•	•	•	•	•	•	•
	Airzone ZBS Wired Think Controller White	AZZB5THINKCB	•	•	•	•	•	•	•	•	•	•	•
	Airzone ZBS Wireless Lite Controller White	AZZB5LITERB	•	•	•	•	•	•	•	•	•	•	•
	Airzone ZBS Wireless Think Controller White	AZZB5THINKRB	•	•	•	•	•	•	•	•	•	•	•
	Deluxe Wired MA Remote Controller†	PAR-40MAAU	•	•	•	•	•	•	•	•	•	•	•
	Simple MA Remote Controller†	PAC-YT53CRAU-J	•	•	•	•	•	•	•	•	•	•	•
	Touch MA Controller†	PAR-CT01MAU-SB	•	•	•	•	•	•	•	•	•	•	•
Wireless Remote Controller	kumo touch™ RedLINK™ Wireless Controller	MHK2	•	•	•	•	•	•	•	•	•	•	•
	Wireless MA Receiver	PAR-FA32MA-W	•	•	•	•	•	•	•	•	•	•	•
	Wireless MA Remote Controller	PAR-FL32MA-E	•	•	•	•	•	•	•	•	•	•	•
	Wireless Signal Receiver	PAR-SA9CA-E	•	•	•	•	•	•	•	•	•	•	•

# Additional M-Series Information

## Port Adapters Parts Numbers

Model Name	Diameter A	Diameter B
MAC-A454JP-E	3/8"	1/2"
MAC-A455JP-E	1/2"	3/8"
MAC-A456JP-E	1/2"	5/8"
PAC-SG76RJ-E	3/8"	5/8"
ADP5834	5/8"	3/4"
PAC-493PI	1/4"	3/8"

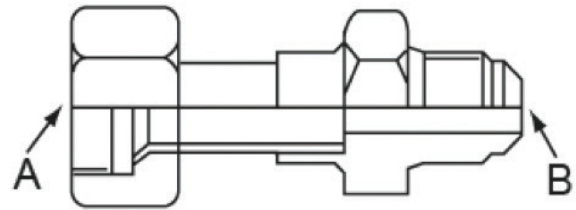

Diameter A = Female

Diameter B = Male

## Multi-zone Efficiency Ratings

Model	Configuration	SEER	EER	HSPF
MXZ-2C20NA2	Ducted	16.00	10.00	9.30
	Mixed	18.00	11.35	9.65
	Non-Ducted	20.00	12.70	10.00
MXZ-3C24NA2	Ducted	16.00	11.20	9.20
	Mixed	18.00	12.40	9.50
	Non-Ducted	20.00	13.60	9.80
MXZ-3C30NA2	Ducted	16.20	9.60	9.60
	Mixed	17.60	10.10	10.10
	Non-Ducted	19.00	10.60	10.60
MXZ-4C36NA2	Ducted	16.00	8.70	9.80
	Mixed	17.60	9.05	10.40
	Non-Ducted	19.20	9.40	11.00
MXZ-5C42NA2	Ducted	15.20	9.00	9.10
	Mixed	17.45	9.10	9.70
	Non-Ducted	19.70	9.20	10.30
MXZ-8C48NA2	Ducted	16.00	10.00	10.10
	Mixed	18.00	11.10	10.80
	Non-Ducted	20.00	12.20	11.50
MXZ-8C60NA2	Ducted	17.00	10.00	10.70
	Mixed	18.20	11.20	10.70
	Non-Ducted	19.50	12.50	10.70
MXZ-2C20NAHZ2	Ducted	15.00	11.00	9.50
	Mixed	16.08	12.65	9.8
	Non-Ducted	17.15	14.3	10.1
MXZ-3C24NAHZ2	Ducted	15.50	10.00	9.00
	Mixed	17.25	11.75	9.50
	Non-Ducted	19.00	13.50	10.00
MXZ-3C30NAHZ2	Ducted	16.00	10.30	9.80
	Mixed	17.00	11.40	10.40
	Non-Ducted	18.00	12.50	11.00
MXZ-4C36NAHZ2	Ducted	17.50	12.50	11.00
	Mixed	18.70	13.20	11.10
	Non-Ducted	20.00	14.00	11.30
MXZ-5C42NAHZ2	Ducted	17.00	10.80	10.60
	Mixed	18.50	12.20	10.80
	Non-Ducted	20.00	13.40	11.00
MXZ-8C48NAHZ2	Ducted	16.00	10.00	10.10
	Mixed	18.00	11.10	10.80
	Non-Ducted	20.00	12.20	11.50

## M-Series Air Outlet Coverage Range\*

Model	Mode	Function	Airflow (CFM)	Coverage (FT)
MSZ-FS06NA, MSZ-FS09NA	HEAT	DRY	437	29.8
	COOL	WET	328	22.5
MSZ-FS12NA	HEAT	DRY	454	31.0
	COOL	WET	364	24.8
MSZ-FS15NA	HEAT	DRY	514	34.9
	COOL	WET	376	25.6
MSZ-FS18NA	HEAT	DRY	514	34.9
	COOL	WET	376	25.6
MSZ-GL06NA, MSZ/Y-GL09NA, MSZ/Y-GL12NA	HEAT	DRY	406	29.5
	COOL	WET	286	21.0
MSZ/Y-GL15NA	HEAT	DRY	463	33.5
	COOL	WET	385	28.0
MSZ/Y-GL18NA	HEAT	DRY	646	44.0
	COOL	WET	581	39.7
MSZ/Y-GL24NA	HEAT	DRY	738	36.9
	COOL	WET	661	33.2
MSZ/Y-D30NA, MSZ/Y-D36NA	HEAT	DRY	848	45.0
	COOL	WET	763	40.7
MFZ-KJ09NA, MFZ-KJ12NA	HEAT	DRY	417	29.6
	COOL	WET	354	25.3
MFZ-KJ15NA	HEAT	DRY	470	33.3
	COOL	WET	366	26.2
MFZ-KJ18NA	HEAT	DRY	470	33.3
	COOL	WET	417	29.7
SLZ-KF09NA	HEAT	DRY	300	15.1
	COOL	WET	270	13.7
SLZ-KF12NA	HEAT	DRY	336	16.9
	COOL	WET	302	15.2
SLZ-KF15NA	HEAT	DRY	405	20.3
	COOL	WET	365	18.3
SLZ-KF18NA	HEAT	DRY	475	23.7
	COOL	WET	429	21.4
MSZ-EF09NA(B/S/W)	HEAT	DRY	420	29.2
	COOL	WET	319	22.3
MSZ-EF12NA(B/S/W)	HEAT	DRY	448	31.1
	COOL	WET	319	22.3
MSZ-EF15NA(B/S/W)	HEAT	DRY	448	31.1
	COOL	WET	313	21.9
MSZ-EF18NA(B/S/W)	HEAT	DRY	466	32.3
	COOL	WET	334	23.4
MSZ-HM09NA, MSZ-HM12NA	HEAT	DRY	406	29.5
	COOL	WET	286	21.0
MSZ-HM15NA	HEAT	DRY	463	33.5
	COOL	WET	385	28.0
MSZ-HM18NA	HEAT	DRY	625	42.6
	COOL	WET	562	38.4
MSZ-HM24NA	HEAT	DRY	702	47.7
	COOL	WET	632	43.1
MSZ-JP09WA	HEAT	DRY	406	29.5
	COOL	WET	364	26.5
MSZ-JP12WA	HEAT	DRY	406	29.5
	COOL	WET	364	26.5
MSZ-WR09NA	HEAT	DRY	406	29.5
	COOL	WET	286	21.0
MSZ-WR12NA	HEAT	DRY	406	29.5
	COOL	WET	286	21.0
MSZ-WR18NA	HEAT	DRY	625	42.6
	COOL	WET	562	38.4
MSZ-WR24NA	HEAT	DRY	702	47.7
	COOL	WET	632	43.1
MLZ-KP09NA	HEAT	DRY	311	20.7
	COOL	WET	325	21.7
MLZ-KP12NA	HEAT	DRY	332	22.1
	COOL	WET	350	23.3
MLZ-KP18NA	HEAT	DRY	403	26.7
	COOL	WET	417	27.6

# Heating Capacity (M-Series)

Outdoor Temperature Degrees		50° F	41° F	32° F	23° F	14° F	5° F	-4° F	-13° F
MSZ-FS06NA-U1 / MUZ-FS06NA-U1	Heating Capacity (BTU/H)	14,445	13,703	12,962	12,149	11,037	9,924	8,700	7,721
	Percentage of Rated Capacity	100%	100%	100%	100%	100%	100%	100%	89%
MSZ-FS06NA-U1 / MUZ-FS06NAH-U1	Heating Capacity (BTU/H)	14,445	13,703	12,962	12,149	11,037	9,924	8,700	7,721
	Percentage of Rated Capacity	100%	100%	100%	100%	100%	100%	100%	89%
MSZ-FS09NA-U1 / MUZ-FS09NA-U1	Heating Capacity (BTU/H)	18,554	17,631	16,707	15,068	13,304	11,540	9,600	8,048
	Percentage of Rated Capacity	100%	100%	100%	100%	100%	100%	100%	84%
MSZ-FS09NA-U1 / MUZ-FS09NAH-U1	Heating Capacity (BTU/H)	18,554	17,631	16,707	15,068	13,304	11,540	9,600	8,048
	Percentage of Rated Capacity	100%	100%	100%	100%	100%	100%	100%	84%
MSZ-FS12NA-U1 / MUZ-FS12NA-U1	Heating Capacity (BTU/H)	21,714	20,524	19,333	18,143	16,464	14,482	12,301	10,556
	Percentage of Rated Capacity	100%	100%	100%	100%	100%	100%	100%	86%
MSZ-FS12NA-U1 / MUZ-FS12NAH-U1	Heating Capacity (BTU/H)	21,714	20,524	19,333	18,143	16,464	14,482	12,301	10,556
	Percentage of Rated Capacity	100%	100%	100%	100%	100%	100%	100%	86%
MSZ-FS15NA-U1 / MUZ-FS15NA-U1	Heating Capacity (BTU/H)	24,544	23,637	22,730	21,823	19,988	18,089	16,001	14,330
	Percentage of Rated Capacity	100%	100%	100%	100%	100%	100%	100%	90%
MSZ-FS15NA-U1 / MUZ-FS15NAH-U1	Heating Capacity (BTU/H)	24,544	23,637	22,730	21,823	19,988	18,089	16,001	14,330
	Percentage of Rated Capacity	100%	100%	100%	100%	100%	100%	100%	90%
MSZ-FS18NA-U1 / MUZ-FS18NA-U1	Heating Capacity (BTU/H)	30,619	29,587	28,556	27,524	25,129	22,211	19,001	16,433
	Percentage of Rated Capacity	100%	100%	100%	100%	100%	100%	100%	86%
MSZ-FS18NA-U1 / MUZ-FS18NAH-U1	Heating Capacity (BTU/H)	30,619	29,587	28,556	27,524	25,129	22,211	19,001	16,433
	Percentage of Rated Capacity	100%	100%	100%	100%	100%	100%	100%	86%
MSZ-GL09NA-U1 / MUZ-GL09NA-U2	Heating Capacity (BTU/H)	10,900	10,900	10,900	10,460	9,480	8,170	6,860	-
	Percentage of Rated Capacity	100%	100%	100%	96%	87%	75%	63%	-
MSZ-GL12NA-U1 / MUZ-GL12NA-U2	Heating Capacity (BTU/H)	14,400	14,400	14,110	12,960	11,660	9,790	7,920	-
	Percentage of Rated Capacity	100%	100%	98%	90%	81%	68%	55%	-
MSZ-GL15NA-U1 / MUZ-GL15NA-U2	Heating Capacity (BTU/H)	18,000	17,100	16,920	16,920	16,200	13,680	11,160	-
	Percentage of Rated Capacity	100%	95%	94%	94%	90%	76%	62%	-
MSZ-GL18NA-U1 / MUZ-GL18NA-U1	Heating Capacity (BTU/H)	21,600	21,600	21,600	19,440	17,060	14,900	12,520	-
	Percentage of Rated Capacity	100%	100%	100%	90%	79%	69%	58%	-
MSZ-GL24NA-U1 / MUZ-GL24NA-U2	Heating Capacity (BTU/H)	27,600	27,600	27,600	26,220	23,460	19,320	15,450	-
	Percentage of Rated Capacity	100%	100%	100%	95%	85%	70%	56%	-
MSZ-HM09NA-U1 / MUZ-HM09NA-U2	Heating Capacity (BTU/H)	10,900	10,570	9,480	8,500	7,300	5,990	4,680	-
	Percentage of Rated Capacity	100%	97%	87%	78%	67%	55%	43%	-
MSZ-HM12NA-U1 / MUZ-HM12NA-U2	Heating Capacity (BTU/H)	12,200	12,200	11,220	10,120	9,020	7,440	5,850	-
	Percentage of Rated Capacity	100%	100%	92%	83%	74%	61%	48%	-
MSZ-HM15NA-U1 / MUZ-HM15NA-U2	Heating Capacity (BTU/H)	18,000	15,300	14,940	14,400	13,680	12,240	10,620	-
	Percentage of Rated Capacity	100%	85%	83%	80%	76%	68%	59%	-
MSZ-HM18NA-U1 / MUZ-HM18NA-U2	Heating Capacity (BTU/H)	18,000	18,000	18,000	16,560	14,580	12,780	10,980	-
	Percentage of Rated Capacity	100%	100%	100%	92%	81%	71%	61%	-
MSZ-HM24NA-U1 / MUZ-HM24NA-U1	Heating Capacity (BTU/H)	26,000	24,440	22,360	20,020	17,680	15,600	13,260	-
	Percentage of Rated Capacity	100%	94%	86%	77%	68%	60%	51%	-
MSZ-D30NA-8 / MUZ-D30NA-1	Heating Capacity (BTU/H)	32,600	28,030	25,420	22,820	19,880	-	-	-
	Percentage of Rated Capacity	100%	86%	78%	70%	61%	-	-	-
MSZ-D36NA-8 / MUZ-D36NA-1	Heating Capacity (BTU/H)	35,200	29,560	27,450	25,340	22,880	-	-	-
	Percentage of Rated Capacity	100%	84%	78%	72%	65%	-	-	-
MSZ-JP09WA-U1 / MUZ-JP09WA-U1	Heating Capacity (BTU/H)	10,900	10,570	9,480	8,500	7,300	5,990	4,680	-
	Percentage of Rated Capacity	100%	97%	87%	78%	67%	55%	43%	-
MSZ-JP12WA-U1 / MUZ-JP12WA-U1	Heating Capacity (BTU/H)	12,200	12,200	11,220	10,120	9,020	7,440	5,850	-
	Percentage of Rated Capacity	100%	100%	92%	83%	74%	61%	48%	-
MSZ-WR09NA-U1 / MUZ-WR09NA-U2	Heating Capacity (BTU/H)	10,900	10,570	9,480	8,500	7,300	5,990	-	-
	Percentage of Rated Capacity	100%	97%	87%	78%	67%	55%	-	-
MSZ-WR12NA-U1 / MUZ-WR12NA-U2	Heating Capacity (BTU/H)	12,200	12,200	11,220	10,120	9,020	7,440	-	-
	Percentage of Rated Capacity	100%	100%	92%	83%	74%	61%	-	-
MSZ-WR18NA-U1 / MUZ-WR18NA-U2	Heating Capacity (BTU/H)	18,000	18,000	18,000	16,560	14,580	12,780	-	-
	Percentage of Rated Capacity	100%	100%	100%	92%	81%	71%	-	-
MSZ-WR24NA-U1 / MUZ-WR24NA-U1	Heating Capacity (BTU/H)	26,000	24,440	22,360	20,020	17,680	15,600	-	-
	Percentage of Rated Capacity	100%	94%	86%	77%	68%	60%	-	-
MFZ-KJ09NA-U1 / MUFZ-KJ09NAHZ-U1	Heating Capacity (BTU/H)	11,000	11,000	11,000	11,000	11,000	11,000	9,130	7,26083%
	Percentage of Rated Capacity	100%	100%	100%	100%	100%	100%	83%	66%

# Heating Capacity (M-Series)

Outdoor Temperature Degrees		50° F	41° F	32° F	23° F	14° F	5° F	-4° F	-13° F
MFZ-KJ12NA-U1 / MUZ-KJ12NAHZ-U1	Heating Capacity (BTU/H)	13,000	13,000	13,000	13,000	13,000	13,000	10,790	8,450
	Percentage of Rated Capacity	100%	100%	100%	100%	100%	100%	83%	65%
MFZ-KJ15NA-U1 / MUZ-KJ15NAHZ-U1	Heating Capacity (BTU/H)	18,000	18,000	18,000	18,000	18,000	18,000	14,940	13,860
	Percentage of Rated Capacity	100%	100%	100%	100%	100%	100%	83%	77%
MFZ-KJ18NA-U1 / MUZ-KJ18NAHZ-U1	Heating Capacity (BTU/H)	21,000	21,000	21,000	21,000	21,000	21,000	18,480	15,960
	Percentage of Rated Capacity	100%	100%	100%	100%	100%	100%	88%	76%
MLZ-KP09NA-U1 / SUZ-KA09NA2	Heating Capacity (BTU/H)	12,000	10,620	9,230	7,840	6,450	5,090	3,770	-
	Percentage of Rated Capacity	100%	89%	77%	65%	54%	42%	31%	-
MLZ-KP12NA-U1 / SUZ-KA12NA2	Heating Capacity (BTU/H)	15,400	13,630	11,850	10,060	8,280	6,540	4,840	-
	Percentage of Rated Capacity	100%	89%	77%	65%	54%	42%	31%	-
MLZ-KP18NA-U1 / SUZ-KA18NA2	Heating Capacity (BTU/H)	20,000	17,700	15,390	13,060	10,760	8,490	6,290	-
	Percentage of Rated Capacity	100%	89%	77%	65%	54%	42%	31%	-
SLZ-KF09NA / SUZ-KA09NA2	Heating Capacity (BTU/H)	11,000	9,730	8,460	7,180	5,920	4,670	3,460	-
	Percentage of Rated Capacity	100%	89%	77%	65%	54%	42%	31%	-
SLZ-KF12NA / SUZ-KA12NA2	Heating Capacity (BTU/H)	13,000	11,510	10,000	8,490	6,990	5,520	4,080	-
	Percentage of Rated Capacity	100%	89%	77%	65%	54%	42%	31%	-
SLZ-KF15NA / SUZ-KA15NA2	Heating Capacity (BTU/H)	18,000	15,930	13,850	11,760	9,680	7,640	5,660	-
	Percentage of Rated Capacity	100%	89%	77%	65%	54%	42%	31%	-
SLZ-KF18NA / SUZ-KA18NA2	Heating Capacity (BTU/H)	19,700	17,440	15,150	12,870	10,600	8,370	6,190	-
	Percentage of Rated Capacity	100%	89%	77%	65%	54%	42%	31%	-
SEZ-KD09NA4R1 / SUZ-KA09NA2	Heating Capacity (BTU/H)	12,000	10,620	9,230	7,840	6,450	5,090	3,770	-
	Percentage of Rated Capacity	100%	89%	77%	65%	54%	42%	31%	-
SEZ-KD12NA4R1 / SUZ-KA12NA2	Heating Capacity (BTU/H)	15,000	13,280	11,540	9,800	8,070	6,370	4,710	-
	Percentage of Rated Capacity	100%	89%	77%	65%	54%	42%	31%	-
SEZ-KD15NA4R1 / SUZ-KA15NA2	Heating Capacity (BTU/H)	18,000	15,930	13,850	11,760	9,680	7,640	5,660	-
	Percentage of Rated Capacity	100%	89%	77%	65%	54%	42%	31%	-
SEZ-KD18NA4R1 / SUZ-KA18NA2	Heating Capacity (BTU/H)	21,600	19,120	16,620	14,110	11,620	9,170	6,790	-
	Percentage of Rated Capacity	100%	89%	77%	65%	54%	42%	31%	-
PEAD-A09AA7 / SUZ-KA09NA2	Heating Capacity (BTU/H)	12,000	10,620	9,230	7,840	6,450	5,090	3,770	-
	Percentage of Rated Capacity	100%	89%	77%	65%	54%	42%	31%	-
PEAD-A12AA7 / SUZ-KA12NA2	Heating Capacity (BTU/H)	15,000	13,280	11,540	9,800	8,070	6,370	4,710	-
	Percentage of Rated Capacity	100%	89%	77%	65%	54%	42%	31%	-
PEAD-A15AA7 / SUZ-KA15NA2	Heating Capacity (BTU/H)	18,000	15,930	13,850	11,760	9,680	7,640	5,660	-
	Percentage of Rated Capacity	100%	89%	77%	65%	54%	42%	31%	-
PEAD-A18AA7 / SUZ-KA18NA2	Heating Capacity (BTU/H)	21,600	19,120	16,620	14,110	11,620	9,170	6,790	-
	Percentage of Rated Capacity	100%	89%	77%	65%	54%	42%	31%	-
PEAD-A24AA7 / SUZ-KA24NA2	Heating Capacity (BTU/H)	25,000	22,130	19,230	16,330	13,450	-	-	-
	Percentage of Rated Capacity	100%	89%	77%	65%	54%	-	-	-
PEAD-A30AA7 / SUZ-KA30NA2	Heating Capacity (BTU/H)	30,000	26,560	23,080	19,600	16,140	-	-	-
	Percentage of Rated Capacity	100%	89%	77%	65%	54%	-	-	-
PEAD-A36AA7 / SUZ-KA36NA2	Heating Capacity (BTU/H)	33,500	29,660	25,770	21,890	18,030	-	-	-
	Percentage of Rated Capacity	100%	89%	77%	65%	54%	-	-	-
SVZ-KP12NA / SUZ-KA12NA2	Heating Capacity (BTU/H)	15,000	13,280	11,540	9,800	8,070	6,370	4,710	-
	Percentage of Rated Capacity	100%	89%	77%	65%	54%	42%	31%	-
SVZ-KP18NA / SUZ-KA18NA2	Heating Capacity (BTU/H)	21,600	19,120	16,620	14,110	11,620	9,170	6,790	-
	Percentage of Rated Capacity	100%	89%	77%	65%	54%	42%	31%	-
SVZ-KP24NA / SUZ-KA24NA2	Heating Capacity (BTU/H)	25,000	22,130	19,230	16,330	13,450	-	-	-
	Percentage of Rated Capacity	100%	89%	77%	65%	54%	-	-	-
SVZ-KP30NA / SUZ-KA30NA2	Heating Capacity (BTU/H)	30,000	26,560	23,080	19,600	16,140	-	-	-
	Percentage of Rated Capacity	100%	89%	77%	65%	54%	-	-	-
SVZ-KP36NA / SUZ-KA36NA2	Heating Capacity (BTU/H)	33,500	29,660	25,770	21,890	18,030	-	-	-
	Percentage of Rated Capacity	100%	89%	77%	65%	54%	-	-	-
MLZ-KP09NA-U1 / SUZ-KA09NAHZ	Heating Capacity (BTU/H)	12,000	12,000	12,000	12,000	12,000	12,000	8,640	5,160
	Percentage of Rated Capacity	100%	100%	100%	100%	100%	100%	72%	43%
MLZ-KP12NA-U1 / SUZ-KA12NAHZ	Heating Capacity (BTU/H)	15,000	15,000	15,000	15,000	15,000	15,000	10,800	6,450
	Percentage of Rated Capacity	100%	100%	100%	100%	100%	100%	72%	43%
MLZ-KP18NA-U1 / SUZ-KA18NAHZ	Heating Capacity (BTU/H)	28,600	18,600	18,600	18,600	18,600	18,600	13,392	7,998
	Percentage of Rated Capacity	100%	100%	100%	100%	100%	100%	72%	43%

# Heating Capacity (M-Series)

Outdoor Temperature Degrees		50° F	41° F	32° F	23° F	14° F	5° F	-4° F	-13° F
SLZ-KF09NA / SUZ-KA09NAHZ	Heating Capacity (BTU/H)	11,000	11,000	11,000	11,000	11,000	11,000	7,920	4,730
	Percentage of Rated Capacity	100%	100%	100%	100%	100%	100%	72%	43%
SLZ-KF12NA / SUZ-KA12NAHZ	Heating Capacity (BTU/H)	13,800	13,800	13,800	13,800	13,800	13,800	9,936	5,934
	Percentage of Rated Capacity	100%	100%	100%	100%	100%	100%	72%	43%
SLZ-KF15NA / SUZ-KA15NAHZ	Heating Capacity (BTU/H)	16,400	16,400	16,400	16,400	16,400	16,400	11,808	7,052
	Percentage of Rated Capacity	100%	100%	100%	100%	100%	100%	72%	43%
SLZ-KF18NA / SUZ-KA18NAHZ	Heating Capacity (BTU/H)	18,800	18,800	18,800	18,800	18,800	18,800	13,536	8,084
	Percentage of Rated Capacity	100%	100%	100%	100%	100%	100%	72%	43%
SEZ-KD09NA4R1 / SUZ-KA09NAHZ	Heating Capacity (BTU/H)	12,500	12,500	12,500	12,500	12,500	12,500	9,000	5,375
	Percentage of Rated Capacity	100%	100%	100%	100%	100%	100%	72%	43%
SEZ-KD12NA4R1 / SUZ-KA12NAHZ	Heating Capacity (BTU/H)	15,000	15,000	15,000	15,000	15,000	15,000	10,800	6,450
	Percentage of Rated Capacity	100%	100%	100%	100%	100%	100%	72%	43%
SEZ-KD15NA4R1 / SUZ-KA15NAHZ	Heating Capacity (BTU/H)	15,000	15,000	15,000	15,000	15,000	15,000	10,800	6,450
	Percentage of Rated Capacity	100%	100%	100%	100%	100%	100%	72%	43%
SEZ-KD18NA4R1 / SUZ-KA18NAHZ	Heating Capacity (BTU/H)	21,600	21,600	21,600	21,600	21,600	21,600	15,552	9,288
	Percentage of Rated Capacity	100%	100%	100%	100%	100%	100%	72%	43%
PEAD-A09AA7 / SUZ-KA09NAHZ	Heating Capacity (BTU/H)	12,000	12,000	12,000	12,000	12,000	12,000	8,640	5,160
	Percentage of Rated Capacity	100%	100%	100%	100%	100%	100%	72%	43%
PEAD-A12AA7 / SUZ-KA12NAHZ	Heating Capacity (BTU/H)	15,000	15,000	15,000	15,000	15,000	15,000	10,800	6,450
	Percentage of Rated Capacity	100%	100%	100%	100%	100%	100%	72%	43%
PEAD-A15AA7 / SUZ-KA15NAHZ	Heating Capacity (BTU/H)	18,000	18,000	18,000	18,000	18,000	18,000	12,960	7,740
	Percentage of Rated Capacity	100%	100%	100%	100%	100%	100%	72%	43%
PEAD-A18AA7 / SUZ-KA18NAHZ	Heating Capacity (BTU/H)	21,600	21,600	21,600	21,600	21,600	21,600	15,552	9,288
	Percentage of Rated Capacity	100%	100%	100%	100%	100%	100%	72%	43%
SVZ-KP12NA / SUZ-KA12NAHZ	Heating Capacity (BTU/H)	15,000	15,000	15,000	15,000	15,000	15,000	10,800	6,450
	Percentage of Rated Capacity	100%	100%	100%	100%	100%	100%	72%	43%
SVZ-KP18NA / SUZ-KA18NAHZ	Heating Capacity (BTU/H)	21,600	21,600	21,600	21,600	21,600	21,600	15,552	9,288
	Percentage of Rated Capacity	100%	100%	100%	100%	100%	100%	72%	43%
SVZ-KP24NA / SUZ-KA24NAHZ	Heating Capacity (BTU/H)	23,000	23,000	23,000	23,000	23,000	23,000	20,470	18,400
	Percentage of Rated Capacity	100%	100%	100%	100%	100%	100%	89%	80%
SVZ-KP30NA / SUZ-KA30NAHZ	Heating Capacity (BTU/H)	32,000	32,000	32,000	32,000	32,000	32,000	28,480	25,600
	Percentage of Rated Capacity	100%	100%	100%	100%	100%	100%	89%	80%
SVZ-KP36NA / SUZ-KA36NAHZ	Heating Capacity (BTU/H)	37,000	37,000	37,000	37,000	37,000	37,000	32,930	29,600
	Percentage of Rated Capacity	100%	100%	100%	100%	100%	100%	89%	80%

# Heating Capacity (MXZ)

Outdoor Temperature Degrees		50° F	41° F	32° F	23° F	14° F	5° F	-4° F	-13° F
MXZ-2C20NA2-U1	Heating Capacity (BTU/H)	22,000	22,000	18,920	15,840	12,980	9,900	-	-
	Percentage of Rated Capacity	100%	100%	86%	72%	59%	45%	-	-
MXZ-3C24NA2-U1	Heating Capacity (BTU/H)	25,000	25,000	24,000	20,750	17,250	13,250	-	-
	Percentage of Rated Capacity	100%	100%	96%	83%	69%	53%	-	-
MXZ-3C30NA2-U1	Heating Capacity (BTU/H)	28,600	28,600	28,020	24,310	20,300	15,730	-	-
	Percentage of Rated Capacity	100%	100%	98%	85%	71%	55%	-	-
MXZ-4C36NA2-U1	Heating Capacity (BTU/H)	36,000	36,000	33,480	29,160	24,120	18,720	-	-
	Percentage of Rated Capacity	100%	100%	93%	81%	67%	52%	-	-
MXZ-5C42NA2-U1	Heating Capacity (BTU/H)	45,000	45,000	41,850	36,450	30,150	23,400	-	-
	Percentage of Rated Capacity	100%	100%	93%	81%	67%	52%	-	-
MXZ-8C48NA2-U1	Heating Capacity (BTU/H)	48,000	48,000	48,000	39,840	32,160	28,800	25,440	-
	Percentage of Rated Capacity	100%	100%	100%	81%	67%	60%	53%	-
MXZ-8C60NA2-U1	Heating Capacity (BTU/H)	60,000	60,000	60,000	51,000	40,800	36,000	31,200	-
	Percentage of Rated Capacity	100%	100%	100%	85%	68%	60%	52%	-
MXZ-2C20NAHZ2-U1	Heating Capacity (BTU/H)	22,000	22,000	22,000	22,000	22,000	22,000	21,120	20,460
	Percentage of Rated Capacity	100%	100%	100%	100%	100%	100%	96%	93%
MXZ-3C24NAHZ2-U1	Heating Capacity (BTU/H)	25,000	25,000	25,000	25,000	25,000	25,000	23,750	22,500
	Percentage of Rated Capacity	100%	100%	100%	100%	100%	100%	95%	90%

## Heating Capacity (MXZ)

Outdoor Temperature Degrees		50° F	41° F	32° F	23° F	14° F	5° F	-4° F	-13° F
MXZ-3C30NAHZ2-U1	Heating Capacity (BTU/H)	28,600	28,600	28,600	28,600	28,600	28,600	26,880	25,160
	Percentage of Rated Capacity	100%	100%	100%	100%	100%	100%	94%	88%
MXZ-4C36NAHZ2-U1	Heating Capacity (BTU/H)	36,000	36,000	36,000	36,000	36,000	36,000	30,960	26,640
	Percentage of Rated Capacity	100%	100%	100%	100%	100%	100%	86%	76%
MXZ-5C42NAHZ2-U1	Heating Capacity (BTU/H)	42,000	42,000	42,000	42,000	42,000	42,000	36,120	31,080
	Percentage of Rated Capacity	100%	100%	100%	100%	100%	100%	86%	74%
MXZ-8C48NAHZ2-U1	Heating Capacity (BTU/H)	48,000	48,000	48,000	48,000	48,000	48,000	41,280	35,520
	Percentage of Rated Capacity	100%	100%	100%	100%	100%	100%	86%	74%

## Additional P-Series Information

### Outlet Air Speed and Coverage Range\*

Model	Airflow (CFM)	Air Speed (ft/sec)	Coverage Range (ft)
PCA-A24KA7	670	10.2	32
PCA-A30KA7	705	10.5	33
PCA-A36KA7	990	11.8	41
PCA-A42KA7	1,025	12.1	42
PKA-A12HA7	425	20.0	35
PKA-A18HA7	425	20.0	35
PKA-A24KA7	775	19.7	47
PKA-A30KA7	775	19.7	47
PKA-A36KA7	920	22.3	53
PLA-A12EA7	530	7.8	13
PLA-A18EA7	600	8.8	14
PLA-A24EA7	810	11.9	19
PLA-A30EA7	880	12.9	21
PLA-A36EA7	1,200	17.6	28
PLA-A42EA7	1,200	17.6	28

\*Air coverage represents the distance with 0.8 ft/sec air speed when blowing out horizontally from the unit operating at the high fan speed. This is a general guideline; actual coverage depends on size and layout of the room.

# Correction Factors

## Cooling Correction Factors: PUY

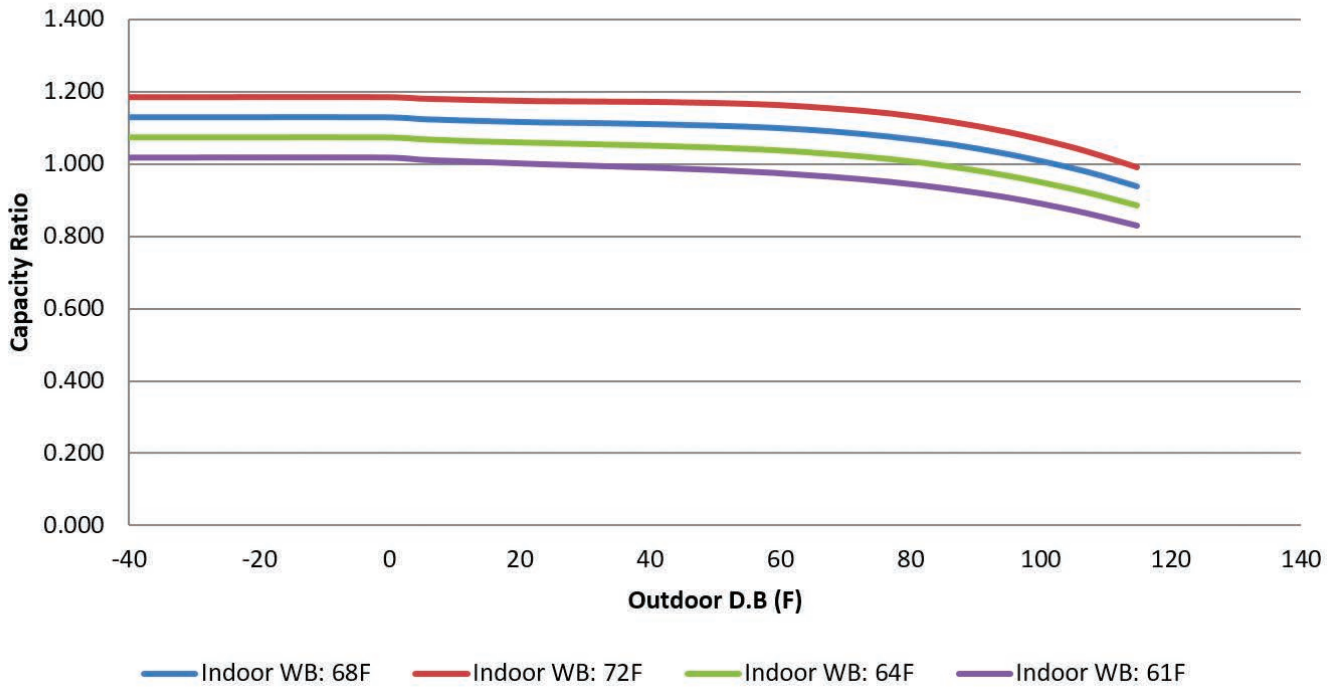

## Cooling Piping Correction Factors: PUY

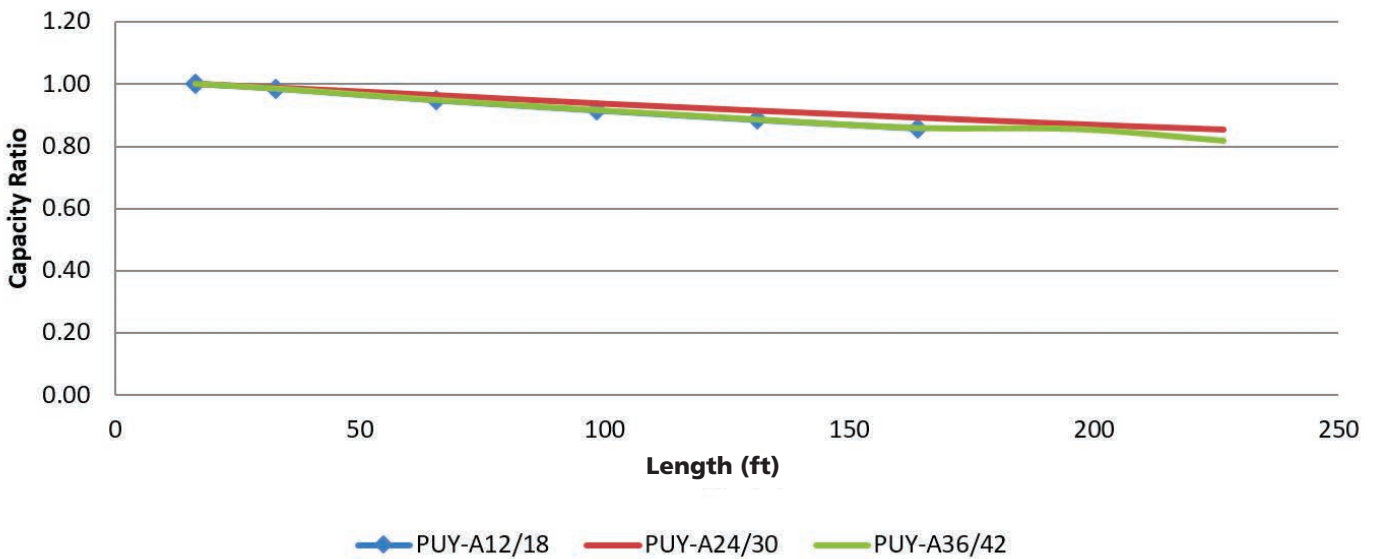



### Cooling Correction Factors: PUZ

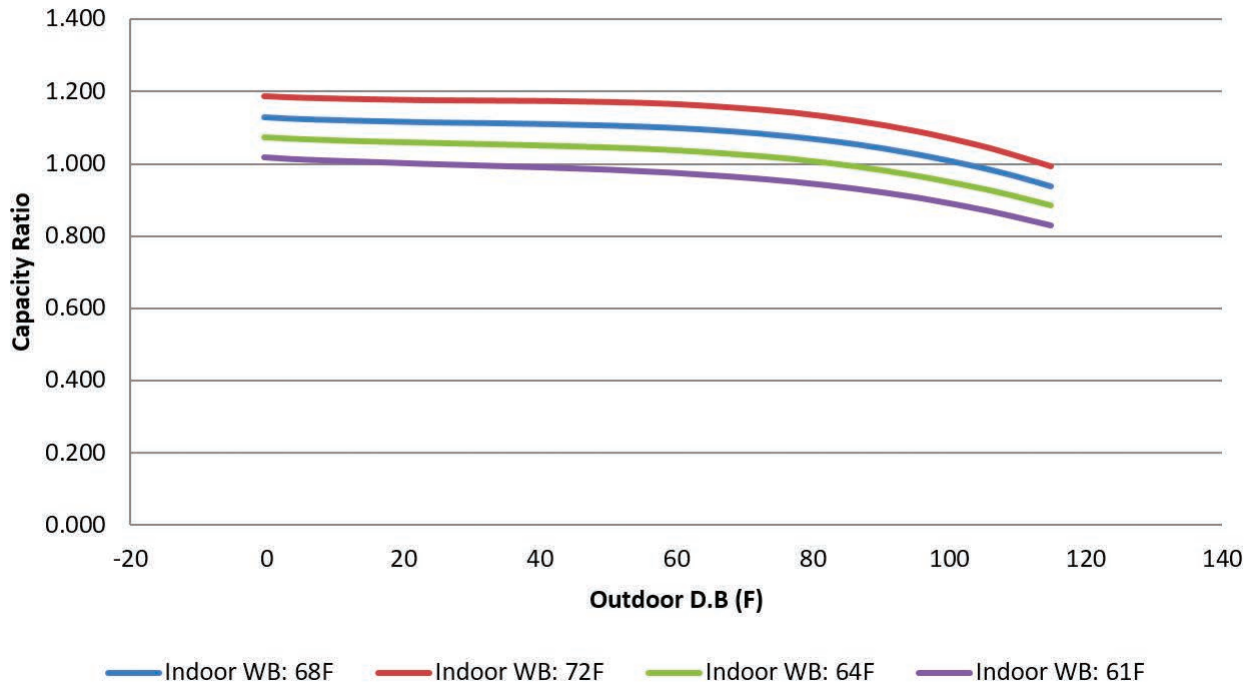

### Heating Correction Factors: PUZ

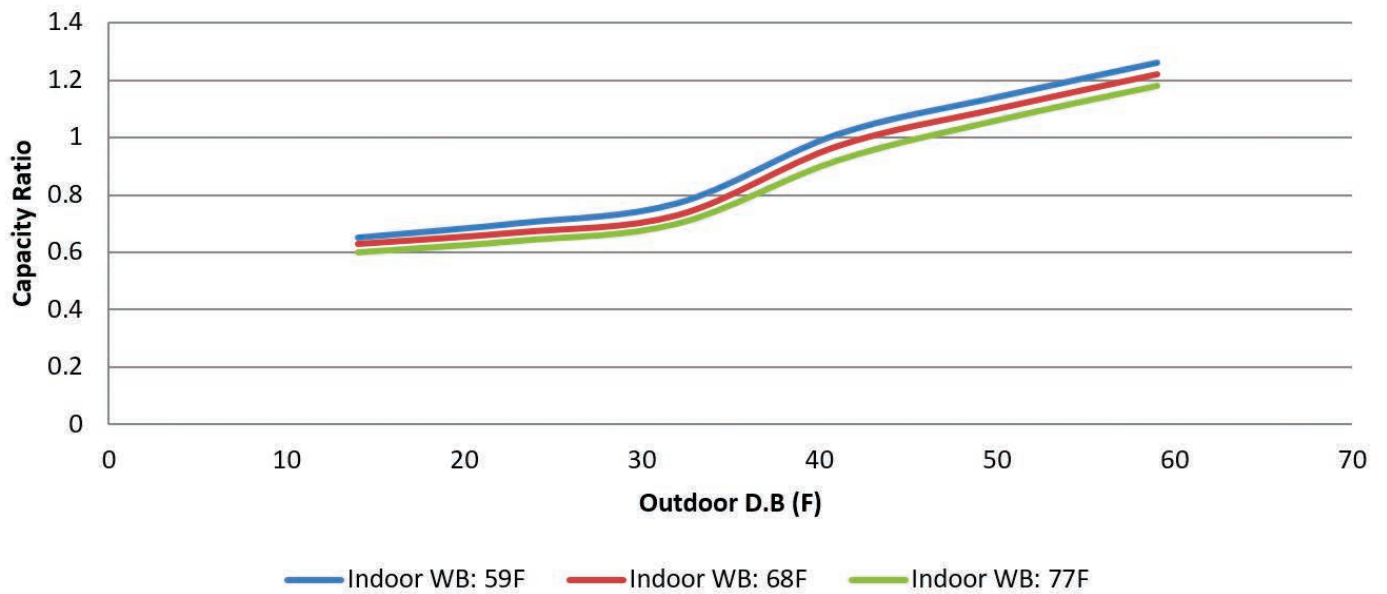

# Correction Factors

## Cooling Piping Correction Factors: PUZ

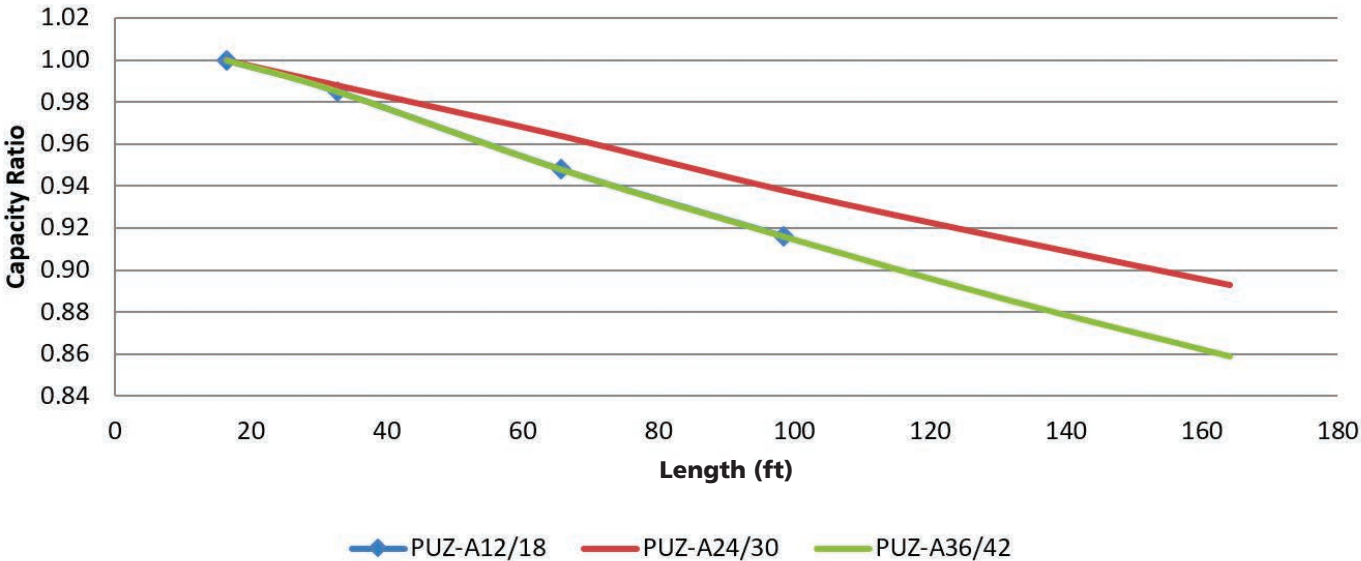

## Cooling Correction Factors: PUZ-HA

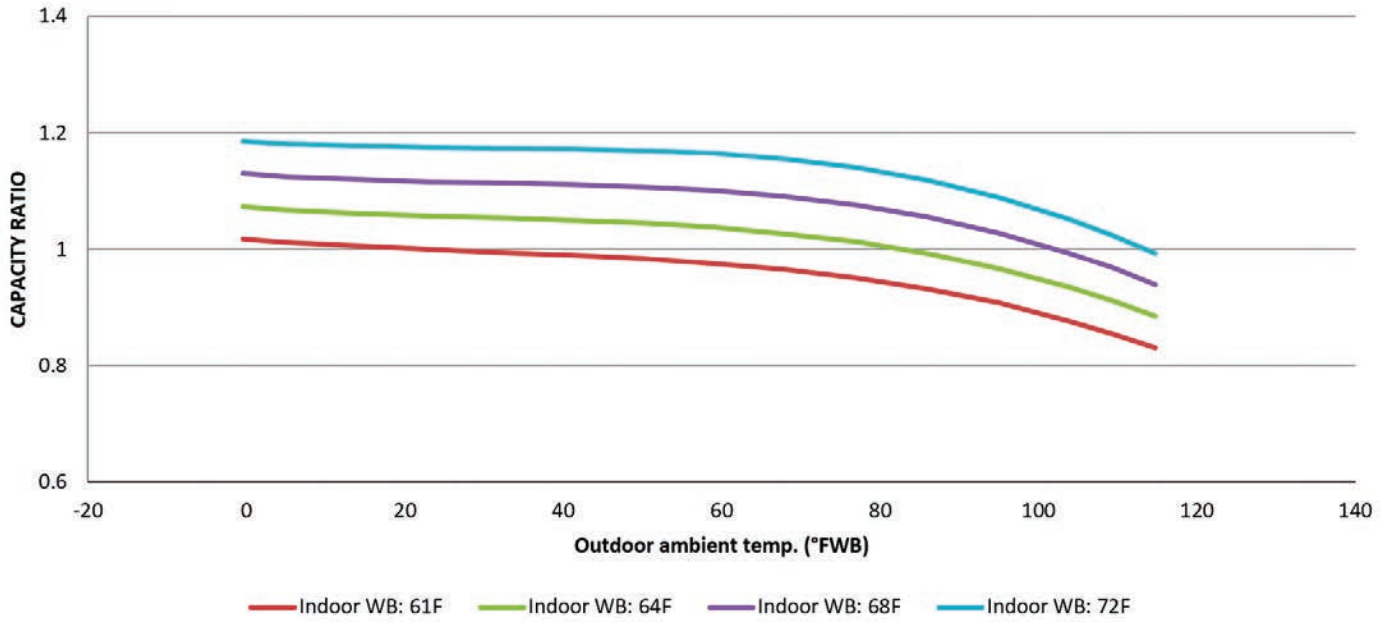

## Heating Correction Factors: PUZ-HA

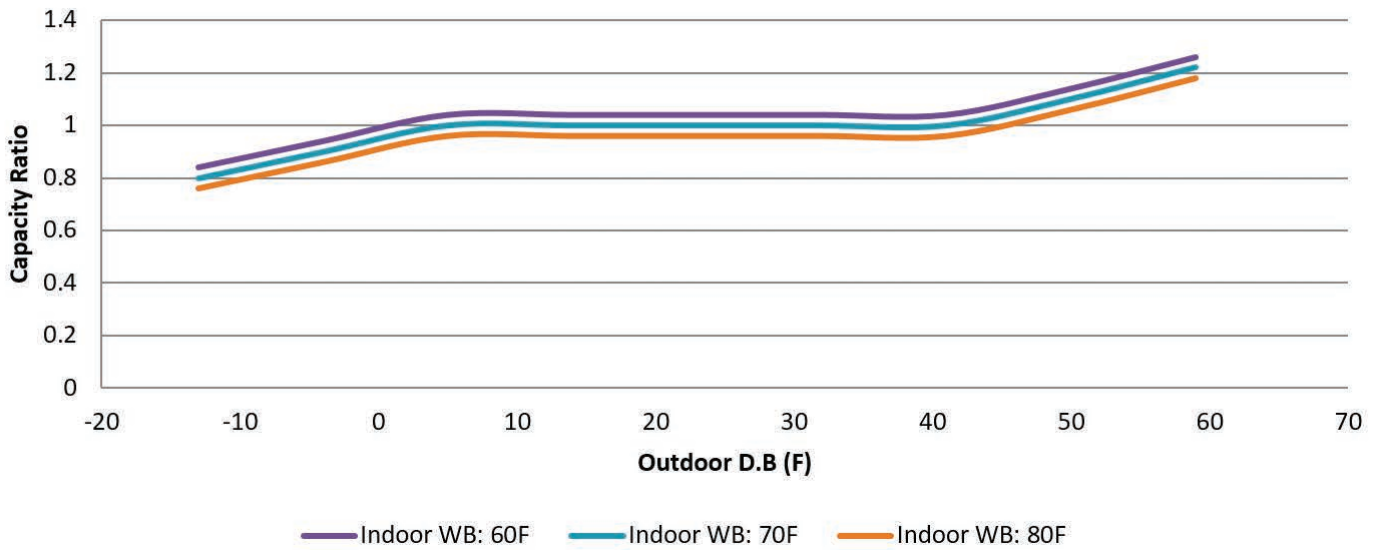

# External Dimensions: M-Series

Unit: inch

MSZ-FS06NA MSZ-FS09NA MSZ-FS12NA  
MSZ-FS15NA MSZ-FS18NA MSZ-FS18NA

## INDOOR UNIT

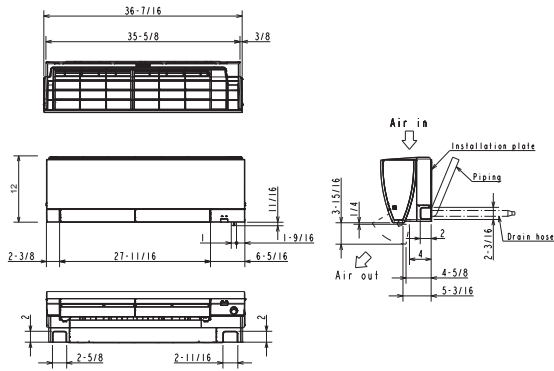

MSZ-EF09NA(W)(B)(S) MSZ-EF12NA(W)(B)(S)  
MSZ-EF15NA(W)(B)(S) MSZ-EF18NA(W)(B)(S)

## INDOOR UNIT

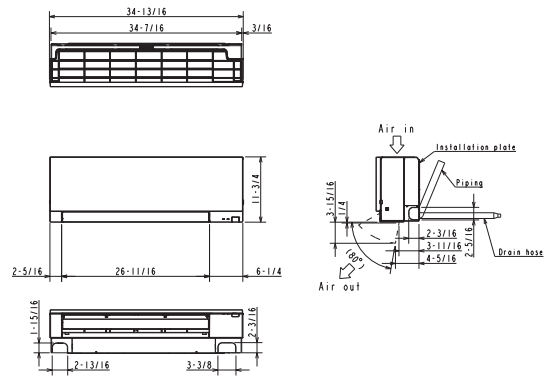

MSZ-GL06NA  
MSZ-GL09NA MSY-GL09NA  
MSZ-GL12NA MSY-GL12NA  
MSZ-GL15NA MSY-GL15NA

## INDOOR UNIT

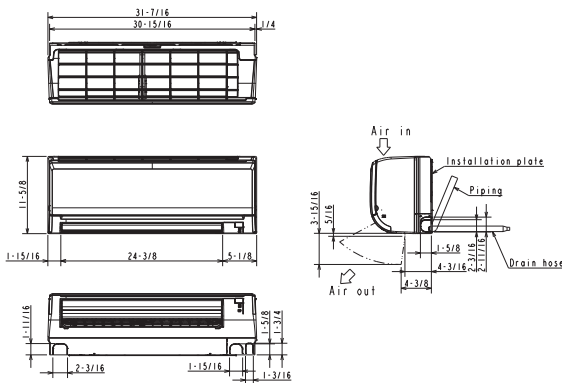

MSZ-GL18NA MSY-GL18NA

## INDOOR UNIT

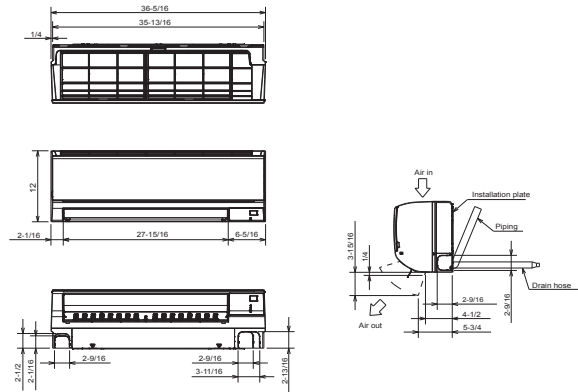

# M-Series

Unit : inch

MSZ-GL24NA MSY-GL24NA

INDOOR UNIT

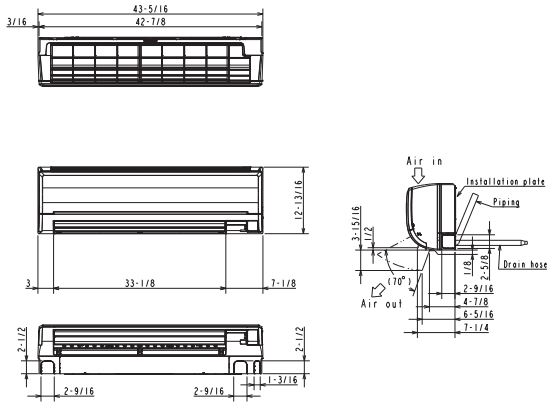

MSZ-D30NA MSY-D30NA  
MSZ-D36NA MSY-D36NA

INDOOR UNIT

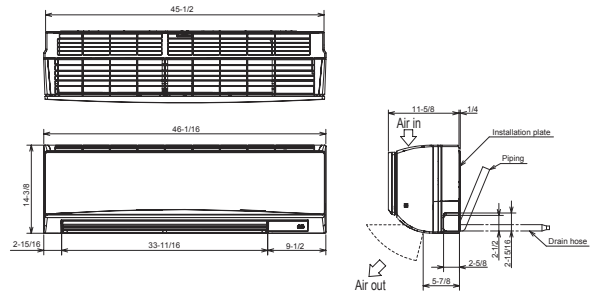

MSZ-HM09NA MSZ-JP09WA  
MSZ-HM12NA MSZ-JP12WA  
MSZ-HM15NA MSZ-WR09NA  
MSZ-WR12NA

INDOOR UNIT

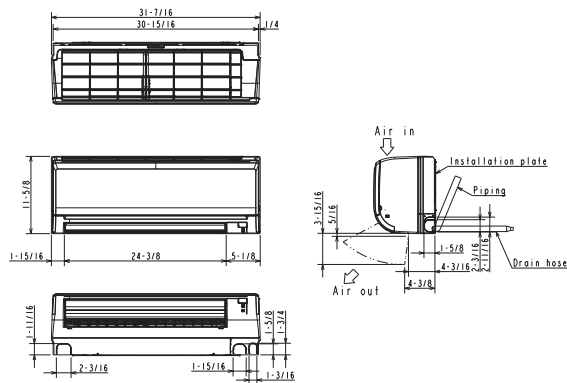

MSZ-HM18NA MSZ-WR18NA  
MSZ-HM24NA MSZ-WR24NA

INDOOR UNIT

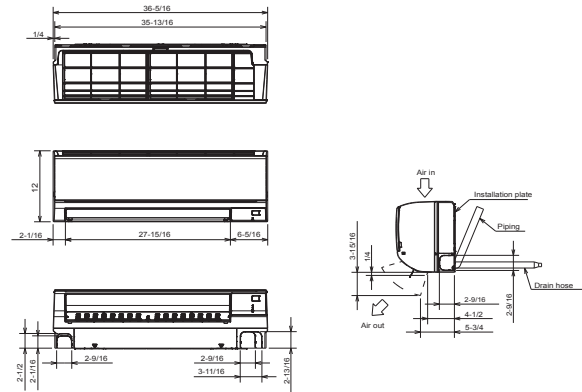

# M-Series

SVZ-KP12NA  
SVZ-KP18NA  
SVZ-KP24NA  
SVZ-KP30NA  
SVZ-KP36NA

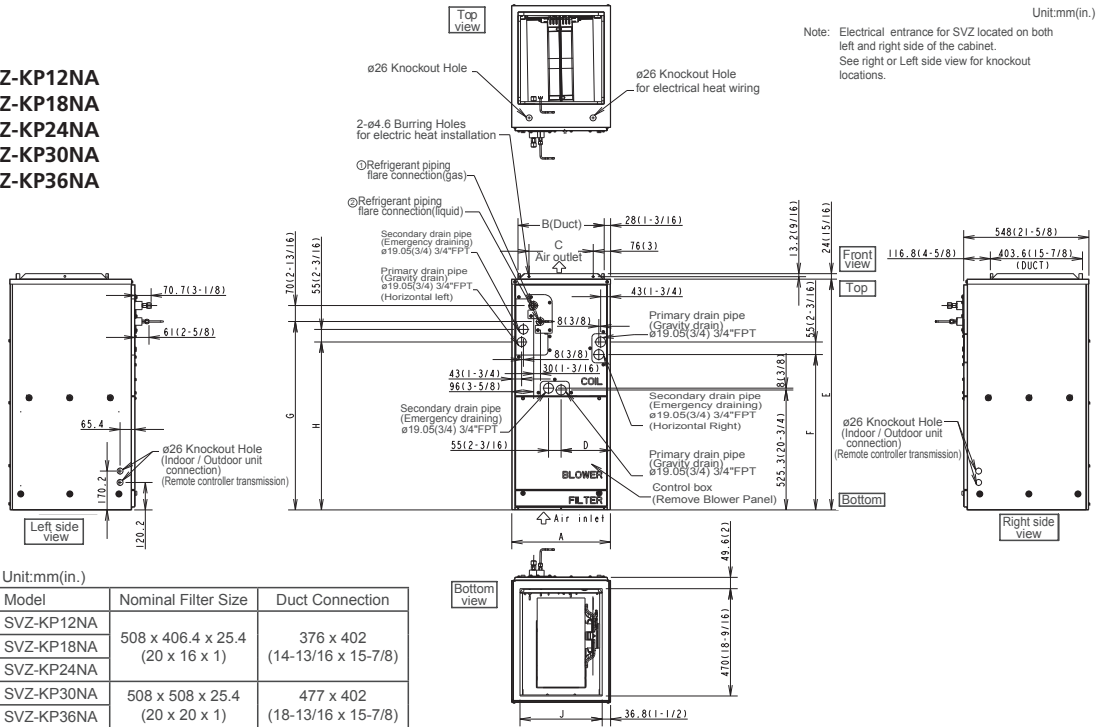

Model	A	B	C	D	E	F	G	H	J	Gas Pipe	Liquid pipe
SVZ-KP12NA	432 (17)	376 (14-13/16)	281 (11-1/8)	224 (8-7/8)	1,010.8 (39-13/16)	680 (26-13/16)	823 (32-7/16)	735.5 (29)	360 (14-3/16)	ø 9.52 (3/8) ø 12.7 (1/2)	ø 6.35 (1/4)
SVZ-KP30NA	534 (21)	477 (18-13/16)	382.6 (15-1/8)	266.5 (10-1/2)	1,113.8 (43-7/8)	737 (29-1/16)	953.5 (37-9/16)	792 (31-3/16)	461 (18-3/16)	ø 15.88 (5/8)	ø 9.52 (3/8)

## MLZ-KP09NA MLZ-KP12NA MLZ-KP18NA

### INDOOR UNIT

#### INDOOR UNIT OUTLINE DRAWING

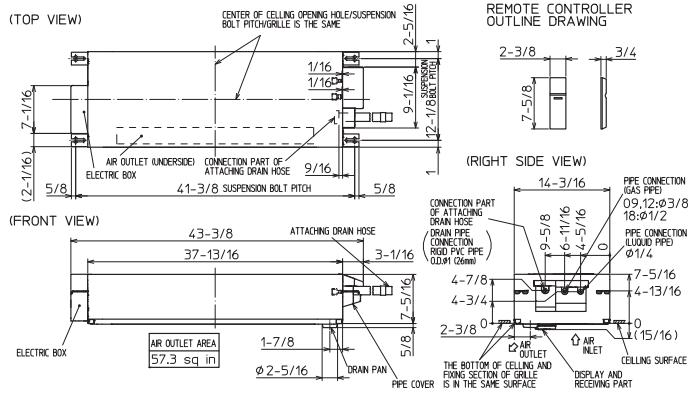

#### INDOOR UNIT DETAIL VIEW (TOP VIEW)

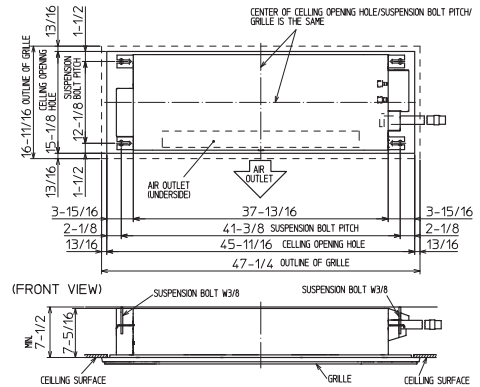

#### GRILLE OUTLINE DRAWING (MLP-444W)

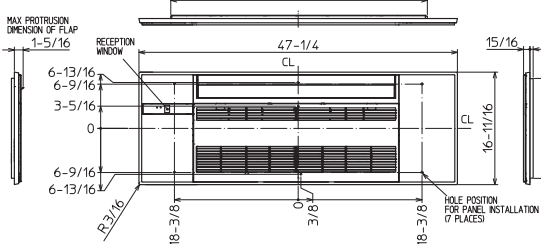

	KP09/12NA	KP18NA
EXTENSION PIPE	LIQUID PIPE O.D. ø 1/4	ø 1/2
CONNECTION OF PIPE	LIQUID PIPE ø 3/8	FLARED CONNECTION ø 1/2
DRAN HOSE	HEAT INSULATOR O.D. CONNECTION I.D. EFFECTIVE LENGTH ø 1-1/4 ø 1	ø 1-1/4 18-7/8
DRAIN PIPE CONNECTION	RIGID PVC PIPE O.D. ø 12(6mm)	

NOTE: CUTTING ATTACHING DRAIN HOSE CAN BE USED.

#### THE METHOD FOR STANDING DRAIN FROM INDOOR UNIT

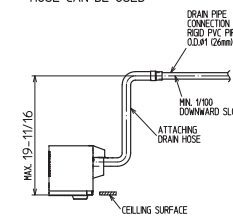



# M-Series

Unit : inch/cm

## SLZ-KF09NA SLZ-KF12NA SLZ-KF15NA SLZ-KF18NA

### INDOOR UNIT

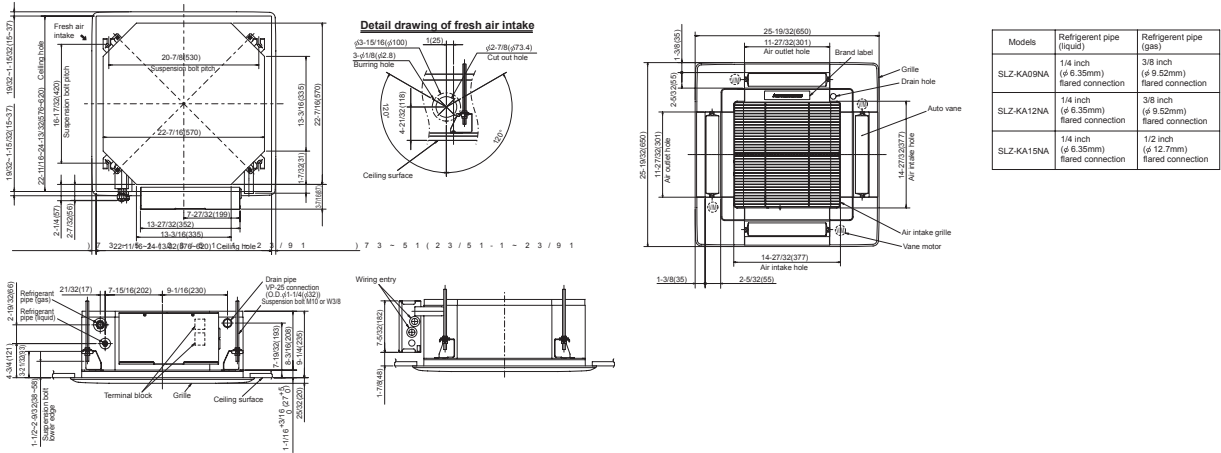

## SEZ-KD09NA4 SEZ-KD12NA4 SEZ-KD15NA4 SEZ-KD18NA4

### INDOOR UNIT

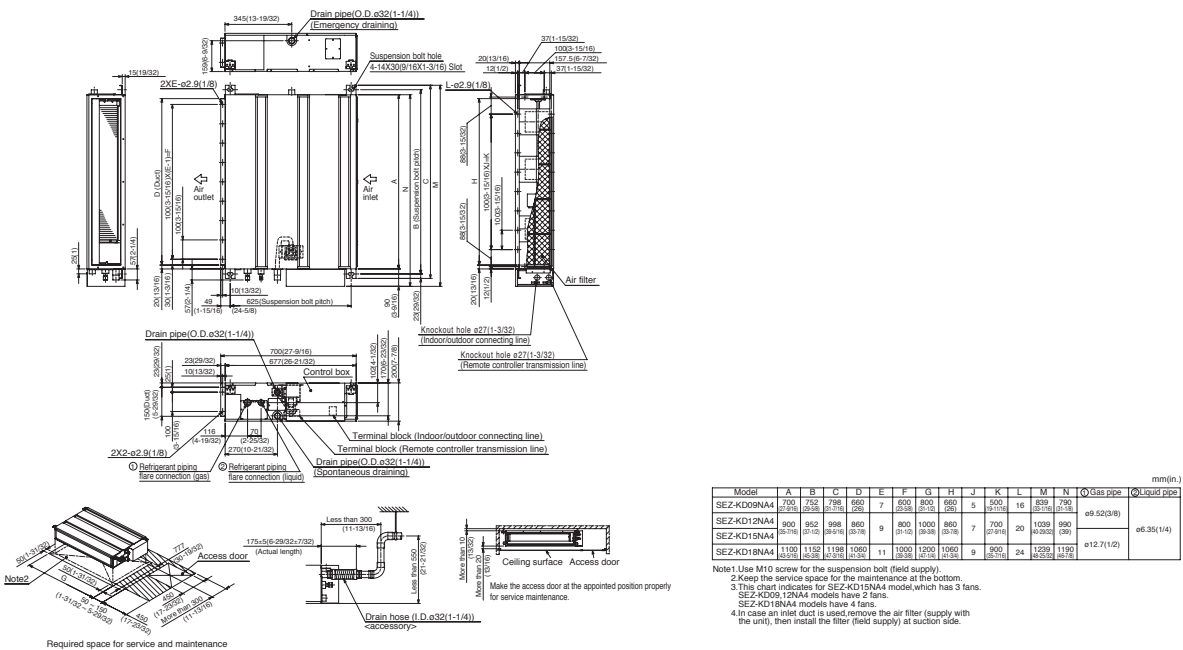



# M-Series

SUZ-KA09NA2 SUZ-KA12NA2 SUZ-KA15NA2

OUTDOOR UNIT

### REQUIRED SPACE

\*1 4 in. (100 mm) or more when front and sides of the unit are clear

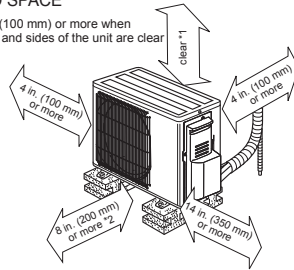

\*2 When any 2 sides of left, right and rear of the unit are clear

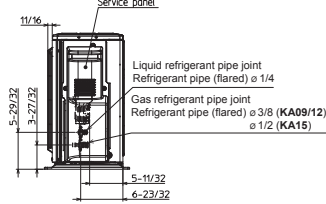
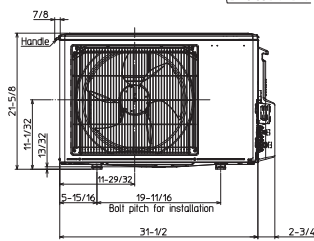
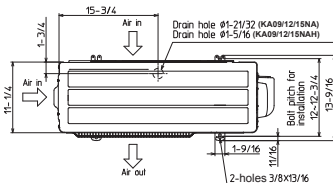

Service panel  
Liquid refrigerant pipe joint  
Refrigerant pipe (flared)  $\varnothing$  1/4  
Gas refrigerant pipe joint  
Refrigerant pipe (flared)  $\varnothing$  3/8 (KA09/12)  
 $\varnothing$  1/2 (KA15)

Unit: inch

SUZ-KA18NA2 SUZ-KA24NA2 SUZ-KA30NA2 SUZ-KA36NA2  
SUZ-KA09NAHZ SUZ-KA12NAHZ SUZ-KA15NAHZ SUZ-KA18NAHZ

OUTDOOR UNIT

### REQUIRED SPACE

\*1 20 in. (500 mm) or more when front and sides of the unit are clear

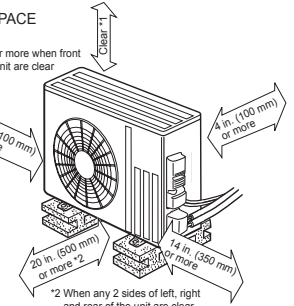

\*2 When any 2 sides of left, right and rear of the unit are clear

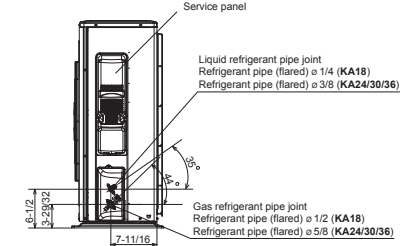
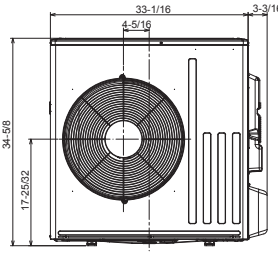
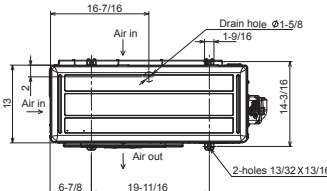

Service panel  
Liquid refrigerant pipe joint  
Refrigerant pipe (flared)  $\varnothing$  1/4 (KA18)  
Refrigerant pipe (flared)  $\varnothing$  3/8 (KA24/30/36)

Gas refrigerant pipe joint  
Refrigerant pipe (flared)  $\varnothing$  1/2 (KA18)  
Refrigerant pipe (flared)  $\varnothing$  5/8 (KA24/30/36)

SUZ-KA24NAHZ

OUTDOOR UNIT

Unit: mm<in>

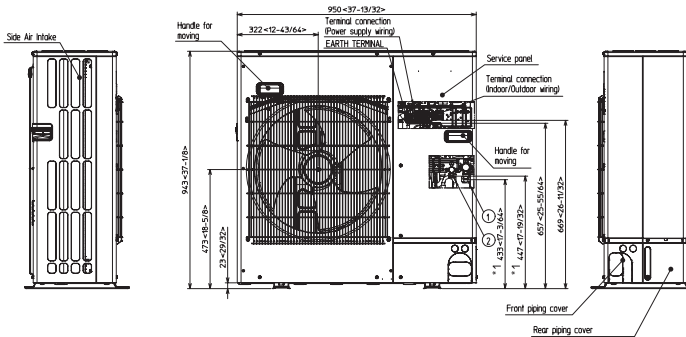
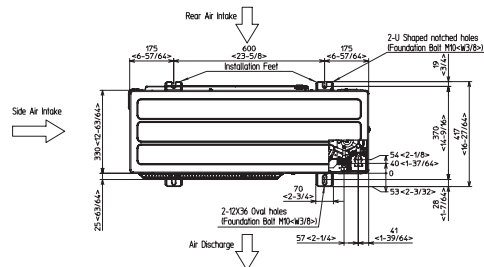

SUZ-KA30NAHZ, SUZ-KA36NAHZ

OUTDOOR UNIT

Unit: inch

Unit: mm<in>

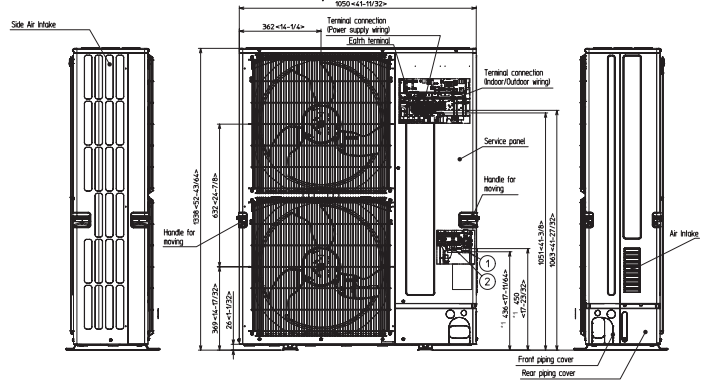
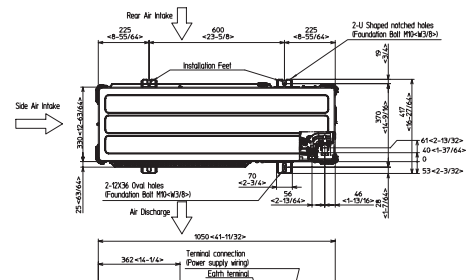

# External Dimensions: P-Series

Unit : inch/cm

## PLA-A12EA7 PLA-A18EA7 PLA-A24EA7 PLA-A30EA7 PLA-A36EA7 PLA-A42EA7

### INDOOR UNIT

MODEL	TYPE	W	H	D	W	H	D
PLA-A12EA7	BRANCHDUCT TYPE	12	6.4	12.4	12.4	6.4	12.4
PLA-A18EA7	BRANCHDUCT TYPE	18	6.4	18.4	18.4	6.4	18.4
PLA-A24EA7	BRANCHDUCT TYPE	24	6.4	24.4	24.4	6.4	24.4
PLA-A30EA7	BRANCHDUCT TYPE	30	6.4	30.4	30.4	6.4	30.4
PLA-A36EA7	BRANCHDUCT TYPE	36	6.4	36.4	36.4	6.4	36.4
PLA-A42EA7	BRANCHDUCT TYPE	42	6.4	42.4	42.4	6.4	42.4

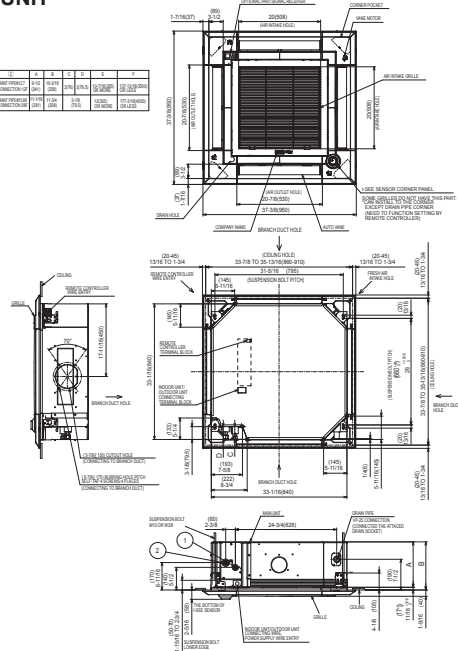

## PKA-A12HA7 PKA-A18HA7 INDOOR UNIT

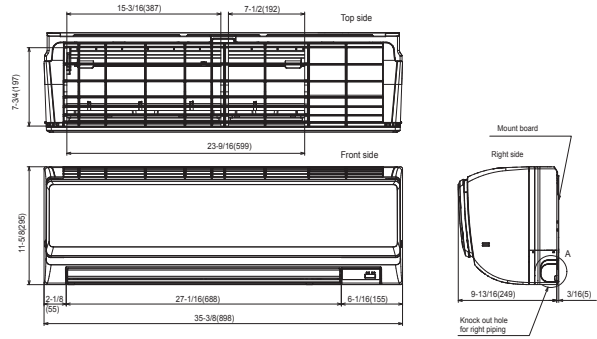

## PKA-A24KA7 PKA-A30KA7 PKA-A36KA7 INDOOR UNIT

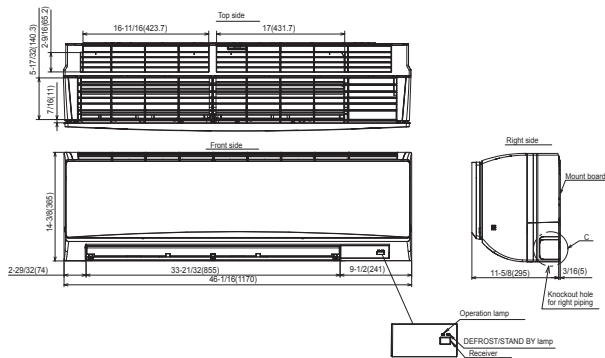

## PCA-A24KA7 PCA-A30KA7 INDOOR UNIT

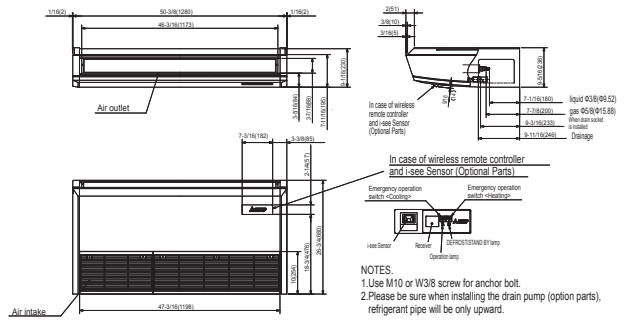

NOTES.  
1. Use M10 or W3/8 screw for anchor bolt.  
2. Please be sure when installing the drain pump (option parts), refrigerant pipe will be only upward.



# P-Series

PUZ-A12NKA7 PUZ-A12NKA7-BS  
 PUZ-A18NKA7 PUZ-A18NKA7-BS  
 PUY-A12NKA7 PUY-A12NKA7-BS  
 PUY-A18NKA7 PUY-A18NKA7-BS

## OUTDOOR UNIT

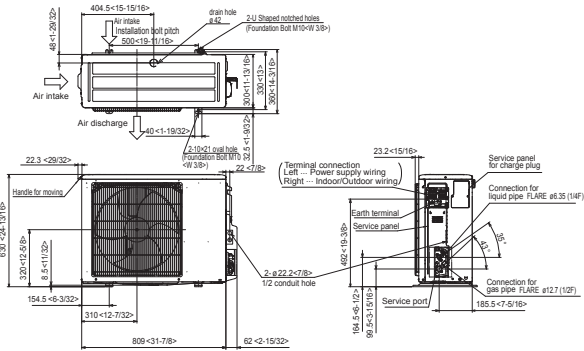

Unit : inch/cm

PUZ-A24NHA7 PUZ-A24NHA7-BS PUZ-HA24NHA1  
 PUZ-A30NHA7 PUZ-A30NHA7-BS  
 PUY-A24NHA7 PUY-A24NHA7-BS  
 PUY-A30NHA7 PUY-A30NHA7-BS

## OUTDOOR UNIT

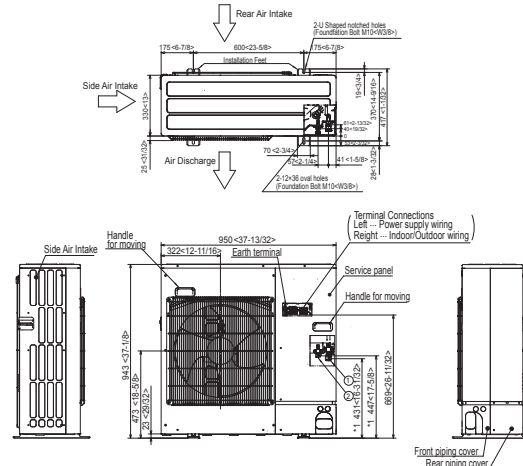

### Example of Notes

- ① --- Refrigerant GAS pipe connection (FLARE)φ15.88x5/8"
- ② --- Refrigerant LIQUID pipe connection (FLARE)φ9.52x3/8"
- \*1 --- Indication of STOP VALVE connection location.

PUZ-A36NKA7 PUZ-A36NKA7-BS PUZ-HA30NHA5  
 PUZ-A42NKA7 PUZ-A42NKA7-BS PUZ-HA36NHA5  
 PUY-A36NKA7 PUY-A36NKA7-BS PUZ-HA30NKA  
 PUY-A42NKA7 PUY-A42NKA7-BS PUZ-HA36NKA  
 PUZ-HA42NKA

## OUTDOOR UNIT

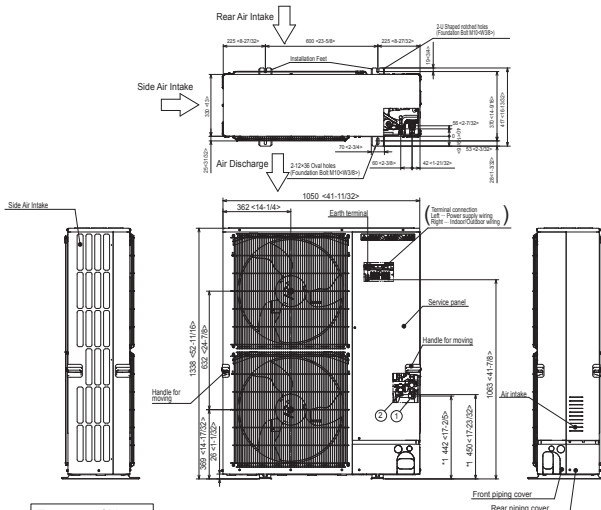

### Example of Notes

- ① --- Refrigerant GAS pipe connection (FLARE)φ15.88x5/8"
- ② --- Refrigerant LIQUID pipe connection (FLARE)φ9.52x3/8"
- \*1 --- Indication of STOP VALVE connection location.

# External Dimensions: MXZ Model

Unit: inch/cm

## MXZ-2C20NA2

### OUTDOOR UNIT

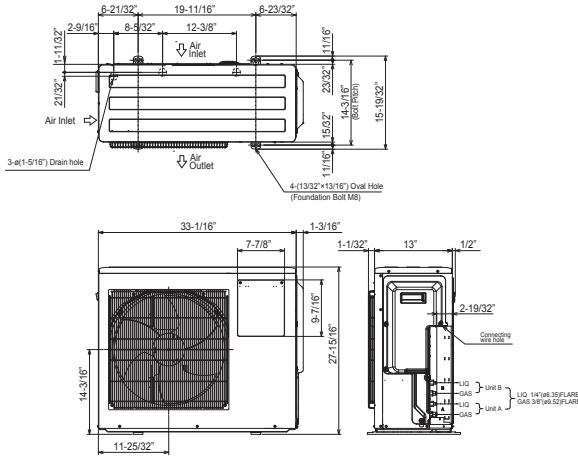

## MXZ-3C24NA2 MXZ-3C30NA2 MXZ-4C36NA2

### OUTDOOR UNIT

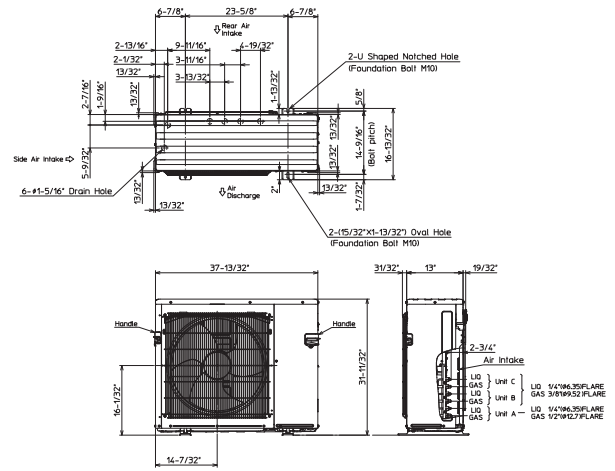

## MXZ-5C42NA2 MXZ-2C20NAHZ2 MXZ-3C24NAHZ2 MXZ-3C30NAHZ2

### OUTDOOR UNIT

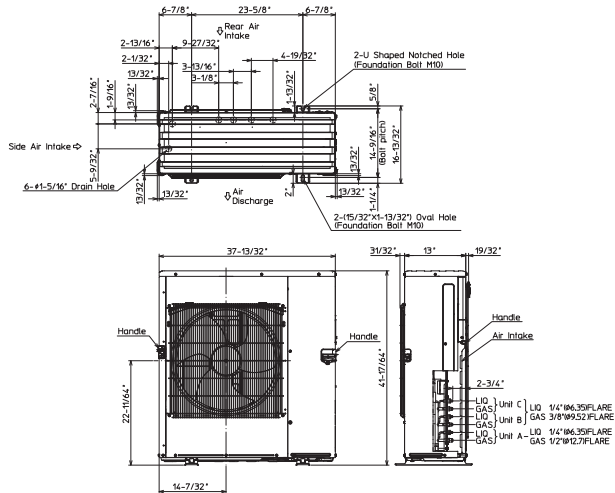

## MXZ-8C48NA2 MXZ-8C60NA2 MXZ-4C36NAHZ2 MXZ-5C42NAHZ2 MXZ-8C48NAHZ2

### OUTDOOR UNIT

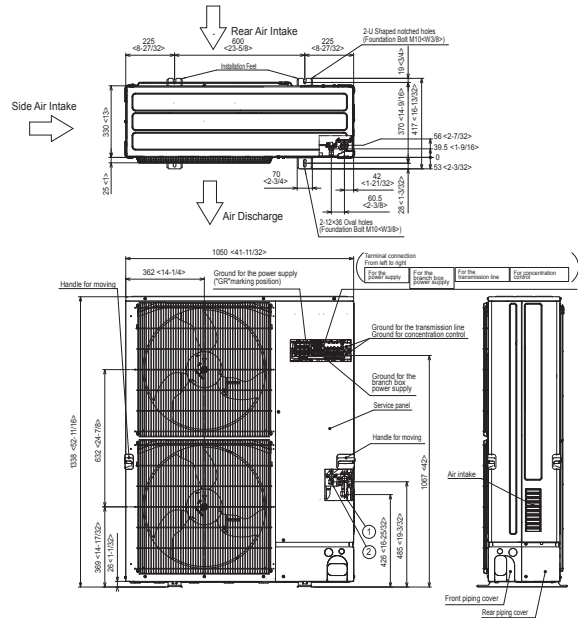

#### Example of Notes

- ① --- Refrigerant GAS pipe connection (FLARE)  $\phi$  15.88-5/8"
- ② --- Refrigerant LIQUID pipe connection (FLARE)  $\phi$  9.52-3/8"

# MXZ Model

Unit : inch/cm

## PAC-MKA32BC

### Branch Box

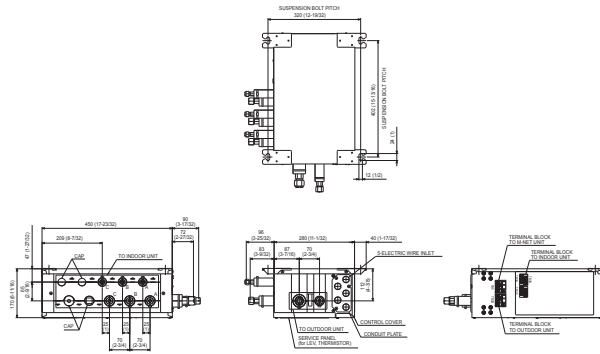

SUSPENSION BOLT : W3/8(M10)

REFRIGERANT PIPE FLARED CONNECTION					Unit: inch
	A	B	C	D	TO OUTDOOR UNIT
LIQUID PIPE	1/2"	1/2"	1/2"	1/2"	3/8"
GAS PIPE	3/8"	3/8"	3/8"	3/8"	5/8"

## PAC-MKA52BC

### Branch Box

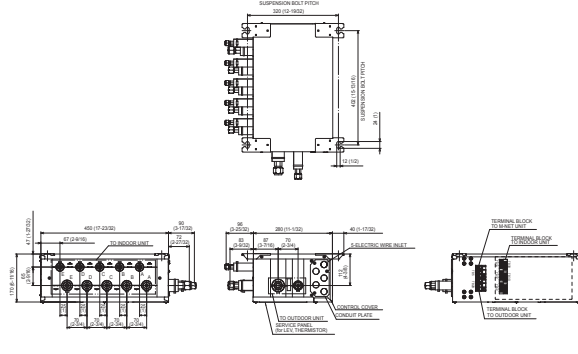

SUSPENSION BOLT : W3/8(M10)

REFRIGERANT PIPE FLARED CONNECTION					Unit: inch
	A	B	C	D	TO OUTDOOR UNIT
LIQUID PIPE	1/2"	1/2"	1/2"	1/2"	3/8"
GAS PIPE	3/8"	3/8"	3/8"	3/8"	5/8"





**MITSUBISHI ELECTRIC**  
**TRANE HVAC US**

© 2021 Mitsubishi Electric Trane HVAC US LLC. All rights reserved.

Mitsubishi Electric, Lossnay, and the three-diamond logo are trademarks of Mitsubishi Electric Corporation. CITY MULTI, kumo cloud, kumo station and H2i are registered trademarks of Mitsubishi Electric US, Inc. is a registered trademark of Trane Technologies plc. All other product names mentioned herein are trademarks or registered trademarks of their respective owners.

ENERGY STAR and the ENERGY STAR mark are registered trademarks owned by the United States Environmental Protection Agency.

Use of the AHRI Certified® mark indicates a manufacturer's participation in the certification program. For verification of certification for individual products, go to [www.ahridirectory.org](http://www.ahridirectory.org).

Specifications shown in this brochure are subject to change without notice. See complete warranty for terms, conditions and limitations. A copy is available from Mitsubishi Electric Trane HVAC US LLC.