

## Longitudinal & Lateral Seismic Clamp Fig. AF730

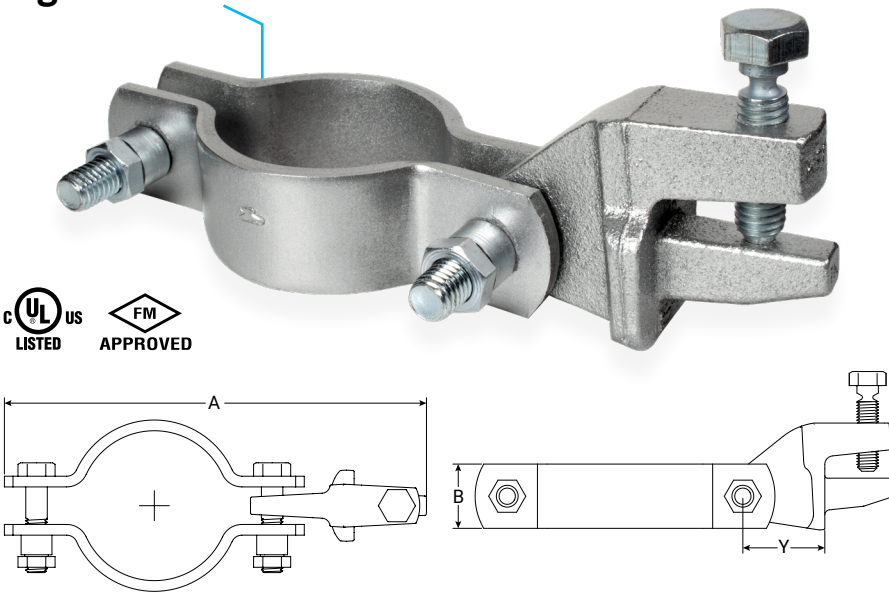

FIG. AF730 Dimensions and Weight

Size	A		B	Y	Weight	
	In./mm	In./mm			In./mm	lbs/kgs
1" (DN25)	7.6	193			2.49	1.13
1½" (DN32)	8.0	203			2.55	1.13
1½" (DN40)	8.2	208			2.64	1.20
2" (DN50)	8.7	221			2.78	1.26
2½"	9.2	234			2.92	1.32
3" (DN80)	9.8	249	1.50	38.1	1.91	48.5
4" (DN100)	10.8	274				
5"	12.1	307			3.81	1.73
6"	13.2	335			4.12	1.87
8"	15.2	386			6.40	2.90
10"	18.1	460			7.60	3.45
12"	20.1	511			8.60	3.90

**Notes:**  
ASC Engineered Solutions™ brand bracing components are designed to be compatible ONLY with other ASC Engineered Solutions brand bracing components, resulting in a Listed seismic bracing assembly. Updated UL listing information may be viewed at [www.ul.com](http://www.ul.com) and updated FM approval information may be viewed at [www.approvalguide.com](http://www.approvalguide.com).

### Material Specifications

#### Size Range

Service Pipe Size: 1" – 12", DN25–DN100

#### Material

Carbon Steel Clamp and Hardware. Ductile Iron Brace Member Attachment Fitting.

#### Finish

Plain

Clamp: Hot Dipped Galvanized per ASTM

A153 Brace Member Attachment Fitting:

Electro-Galvanized per ASTM B633

#### Service

A seismic longitudinal and lateral brace clamp designed to connect a piping system to a brace member. The AF730 rigidly braces piping systems subjected to horizontal and vertical seismic loads.

#### Approvals

cULus Listed (ANSI/UL 203a) and FM Approved (FM 1950–13). FM Tested (ANSI/FM 1950–16). Complies with NFPA 13, ASCE 7, IBC, & MSS SP-127 bracing requirements.

#### Features

- Torque off set screw and nuts provide a visual indication that the desired installation torque values have been achieved.
- Eliminates brace member eccentricity by concentrically loading 1" and 1¼" brace pipes.

#### Ordering

Specify figure number, service pipe size, finish, and description.

#### Disclaimer:

ASC Engineered Solutions does not provide any warranties and specifically disclaims any liability whatsoever with respect to ASC bracing products and components that are used in combination with products, parts or systems not manufactured or sold by ASC. In no event shall ASC be liable for any incidental, direct, consequential, special or indirect damages or lost profits where non-ASC bracing components have been, or are used.

Seis Brace® Seismic Fire Protection Design Tool may be accessed at [www.seisbrace.com](http://www.seisbrace.com)



PROJECT INFORMATION	APPROVAL STAMP
Project:	Approved
Address:	Approved as noted
Contractor:	Not approved
Engineer:	Remarks:
Submittal Date:	
Notes 1:	
Notes 2:	

## Longitudinal & Lateral Seismic Clamp Fig. AF730

FIG. AF730 cULus Listing per ANSI/UL 203a (ASD)

Service Pipe Size	Standard Service Pipe	Specialty Service Pipe	Horizontal Load Rating at Brace Angle							
			Longitudinal Load Rating				Lateral Load Rating			
			30°-44°	45°-59°	60°-90°	Listed	30°-44°	45°-59°	60°-90°	Listed
lbf/kN	lbf/kN	lbf/kN	lbf/kN	lbf/kN	lbf/kN	lbf/kN	lbf/kN	lbf/kN		
1" (DN25)	Sch. 10 Sch. 40 Metric Pipe	Mega-Thread MLT / GL Eddy Thread EZ-Thread	340 1.51	480 2.14	588 2.62	680 3.02	340 1.51	480 2.14	588 2.62	680 3.02
1¼" (DN32)	Sch. 10 Sch. 40 Metric Pipe	Mega-Flow MLT / GL Mega-Thread Eddy Flow Eddy Thread EZ-Thread								
1½" (DN40)	Sch. 10 Sch. 40 Metric Pipe	Mega-Flow MLT / GL Mega-Thread Eddy Flow Eddy Thread Fire-Flo EZ-Thread	375 1.67	530 2.36	649 2.89	750 3.34	375 1.67	530 2.36	649 2.89	750 3.34
2" (DN50)	Sch. 10 Sch. 40 Metric Pipe	Mega-Flow MLT / GL Mega-Thread Eddy Flow Eddy Thread Fire-Flo EZ-Thread								
2½"	Sch. 10 Sch. 40	Mega-Flow Eddy Flow Fire-Flo	545 2.42	770 3.43	943 4.19	1090 4.85	545 2.42	770 3.43	943 4.19	1090 4.85
3" (DN80)	Sch. 10 Sch. 40 Metric Pipe	Mega-Flow Eddy Flow Fire-Flo								
4" (DN100)	Sch. 10 Sch. 40 Metric Pipe	Mega-Flow Eddy Flow Fire-Flo								
5"	Sch. 10 Sch. 40	-								
6"	Sch. 10 Sch. 40	Mega-Flow	942 4.19	1333 5.93	1632 7.26	1885 8.38	942 4.19	1333 5.93	1632 7.26	1885 8.38
8"	Sch. 10 0.188" Wall Sch. 40	-								
10"	0.188" Wall Sch. 40	-								

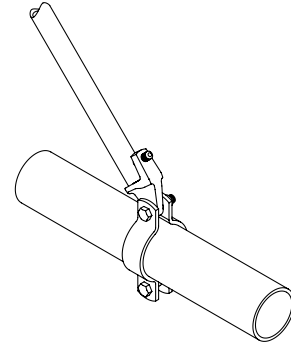

Longitudinal Application

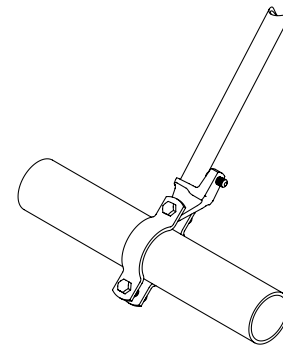

Lateral Application

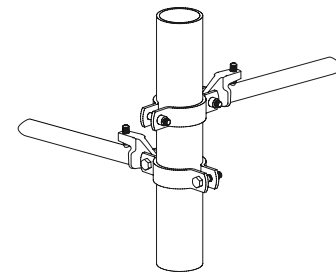

Riser Application

Brace Angles are determined from Vertical.

Sch. 10 & 0.188" Wall Load Ratings may be used for any thicker wall pipe of the same diameter.

Listed load ratings reduced for angle ranges in accordance with NFPA 13-2019 Table 18.5.2.3.

See table on page 4 for UL listed specialty pipes & UL Listed metric service pipes.

See table on page 4 for UL listed brace members.

Load ratings include a minimum safety factor of 2.2 in accordance with NFPA 13-2019 Section A.18.5.2.3.

All load ratings may be used for NFPA 13-2016 designs.



asc-es.com

Building connections that last™

## Longitudinal & Lateral Seismic Clamp Fig. AF730

FIG. AF730 FM Approved (Listing) per FM 1950-13 (ASD)

Service Pipe Size	Standard Service Pipe	Specialty Service Pipe	Horizontal Load Rating at Brace Angle							
			Longitudinal Load Rating				Lateral Load Rating			
			30°-44°	45°-59°	60°-74°	75°-90°	30°-44°	45°-59°	60°-74°	75°-90°
lbf/kN	lbf/kN	lbf/kN	lbf/kN	lbf/kN	lbf/kN	lbf/kN	lbf/kN			
1" (DN25)	Sch. 10 Sch. 40 Metric Pipe	Mega-Thread MLT / GL Eddy Thread EZ-Thread	550	640	670	740	1740	2460	3010	3360
			2.24	2.84	2.98	3.29	7.74	10.94	13.39	14.95
1¼" (DN32)	Sch. 10 Sch. 40 Metric Pipe	Mega-Flow MLT / GL Mega-Thread Eddy Flow Eddy Thread EZ-Thread	740	680	820	1620	1430	2020	2480	2770
			3.29	3.02	3.65	7.21	6.36	8.99	11.03	12.32
1½" (DN40)	Sch. 10 Sch. 40 Metric Pipe	Mega-Flow MLT / GL Mega-Thread Eddy Flow Eddy Thread Fire-Flo EZ-Thread	800	650	790	1800	1790	2530	3100	3460
			3.56	2.89	3.51	8.01	7.96	11.25	13.79	15.39
2" (DN50)	Sch. 10 Sch. 40 Metric Pipe	Mega-Flow MLT / GL Mega-Thread Eddy Flow Eddy Thread Fire-Flo EZ-Thread	830	990	1190	1620	1820	2580	3160	3530
			3.69	4.4	5.29	7.21	8.1	11.48	14.06	15.7
2½"	Sch. 10 Sch. 40	Mega-Flow Eddy Flow Fire-Flo	800	700	850	1930	1610	2280	2790	3120
			3.65	3.11	3.78	8.59	7.16	10.14	12.41	13.88
3" (DN80)	Sch. 10 Sch. 40 Metric Pipe	Mega-Flow Eddy Flow Fire-Flo	960	1330	1540	1700	1550	2200	2690	3010
			4.27	5.92	6.85	7.56	6.89	9.79	11.97	13.39
4" (DN100)	Sch. 10 Sch. 40 Metric Pipe	Mega-Flow Eddy Flow Fire-Flo	760	1040	1270	1400	1260	1790	2190	2440
			3.38	4.63	5.65	6.23	5.6	7.96	9.74	10.85
5"	Sch. 10 Sch. 40	-	890	1230	1410	1550	1260	1790	2190	2440
			3.96	5.47	6.27	6.89	5.6	7.96	9.74	10.85
6"	Sch. 10 Sch. 40	Mega-Flow	700	940	1140	1310	950	1340	1640	1830
			3.11	4.18	5.07	5.83	4.23	5.96	7.3	8.14
8"	0.188" Wall Sch. 40	-	990	1130	1360	1520	1540	2170	2660	2970
			4.4	5.03	6.05	6.76	6.85	9.65	11.82	13.21
10"	0.188" Wall Sch. 40	-	1020	850	1000	1100	1700	2410	2950	3290
			4.54	3.78	4.45	4.89	7.56	10.72	13.12	14.63
12"	0.188" Wall Sch. 40	-	970	1010	1220	1430	1690	2390	2930	3270
			4.31	4.49	5.43	6.36	7.52	10.63	13.03	14.55

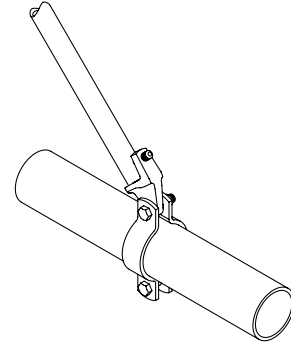

Longitudinal Application

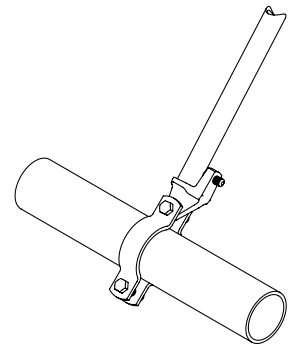

Lateral Application

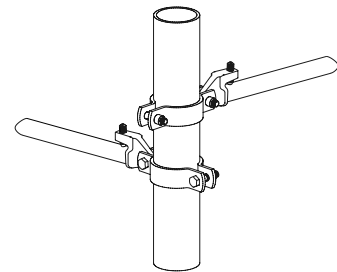

Riser Application

Brace Angles are determined from Vertical.

Sch. 10 & 0.188" Wall Load Ratings may be used for any thicker wall pipe of the same diameter.

Load ratings include a minimum safety factor of 1.5 in accordance with NFPA 13-2016 Section A.9.3.5.2.3. To convert the load ratings above to a safety factor of 2.2 per NFPA 13-2019 Section A.18.5.2.3, multiply load ratings by a factor of 0.68.

To convert to LRFD Load Ratings, ASD Load Ratings may be multiplied by a factor of 1.5.

See table on page 4 for FM approved metric service pipes.

See table on page 4 for FM approved brace members.



asc-es.com

Building connections that last™

## Longitudinal & Lateral Seismic Clamp Fig. AF730

### Method 1 – Connection to Brace Member First

- 1 Slide the brace member over the lower jaw until it contacts the back wall of the brace member attachment fitting.
- 2 Hand tighten the set screw until it contacts the brace member. Continue to torque the set screw until the head breaks off.
- 3 Rotate the brace assembly to the service pipe. Unbolt the back nut & bolt and rotate the clamp halves over the service pipe. Re-assemble the nut and bolt.
- 4 Hand tighten the nuts on both sides of the clamp. Evenly and alternately torque the nut until the head breaks off. It is best practice to tighten the nut at the jaw side first.
- 5 Ensure the brace angle is within the range specified.

### Method 2 – Connection to Service Pipe First

- 1 Unbolt the back nut & bolt and rotate the clamp halves over the service pipe. Re-assemble the nut and bolt.
- 2 Hand tighten the nuts on both sides of the clamp. Evenly and alternately torque the nut until the head breaks off. It is best practice to tighten the nut at the jaw side first.
- 3 Slide the brace member over the lower jaw until it contacts the back wall of the brace member attachment fitting.
- 4 Hand tighten the set screw until it contacts the brace member. Continue to torque the set screw until the head breaks off.

FIG. AF730 cULus Listed & FM Approved Brace Members

Brace Member	Sizes	Standards (or Equivalent)	UL Listed	FM Approved
Sch. 40 NPS Pipe	1", 1¼", 1½", 2"	ASTM A53, A106, A135, or A795	✓	✓
Sch. 40 Metric Pipe		KS D 3562	✓	✓
Metric Pipe	DN25, DN32, DN40, DN50	EN10255H		✓
		GB/T 3091		✓
		JIS G3454		✓

FIG. AF730 cULus Listed & FM Approved Metric Service Pipes

Brace Member	Service Pipe Sizes	UL Listed	FM Approved
KS D 3507 KS D 3537	DN25, DN32, DN40, DN50, DN 80, DN100	✓	✓
KS D 3562 Sch. 40		✓	✓
GB/T 3091 GB/T 3092			✓
JIS G3452			✓
EN 10255M			
EN 10255H			



asc-es.com

Building connections that last™