

# OPERATION AND MAINTENANCE MANUAL

4-1/2" AMERICAN-DARLING® MARK 73-5  
FIRE HYDRANT



# AMERICAN

FLOW CONTROL

**THE RIGHT WAY**



# INDEX

## 4-1/2" AMERICAN - DARLING® MARK 73-5 FIRE HYDRANT

|                                       | Page                |
|---------------------------------------|---------------------|
| <b>INTRODUCTION AND HISTORY</b> ..... | 1A-2                |
| <b>ORDERING</b>                       |                     |
| Dimensions:                           |                     |
| Overall Hydrant.....                  | 1A-3                |
| Optional Bases.....                   | 1A-4                |
| Operating Nut Sizes.....              | 1A-5, 1A-6          |
| Weights.....                          | 1A-7                |
| Friction Loss.....                    | 1A-8                |
| Submittal Sheet.....                  | 1A-9                |
| <b>INSTALLATION AND TESTING</b>       |                     |
| Installation.....                     | 1A-10               |
| Testing.....                          | 1A-11, 1A-12        |
| <b>OPERATION AND MAINTENANCE</b>      |                     |
| Operation and Maintenance.....        | 1A-12, 1A-13        |
| Troubleshooting Guide.....            | 1A-14, 1A-15        |
| <b>REPAIRS</b>                        |                     |
| Parts List.....                       | 1A-16, 1A-17, 1A-18 |
| Spare Parts.....                      | 1A-18               |
| Repair Instructions.....              | 1A-19, 1A-20        |
| Traffic Damage Repair.....            | 1A-21               |
| Nozzle Replacement.....               | 1A-22               |
| Mechanically Attached Nozzles.....    | 1A-23, 1A-24        |
| <b>EXTENDING</b>                      |                     |
| Extension Instructions.....           | 1A-25               |
| <b>SPECIFICATIONS</b> .....           | 1A-26               |



## 4-1/2" AMERICAN - DARLING® MARK 73-5 FIRE HYDRANT

The **4-1/2" American-Darling MARK 73-5** hydrant incorporates over 100 years of experience in design, manufacture and field experience. This means dependable and efficient operation when needed.

Introduced in 1973, the **4-1/2" American-Darling MARK 73-5** hydrant is rated at 250 psig and is seat tested at 500 psig. The hydrant meets or exceeds all requirements of ANSI/AWWA C502 for dry barrel hydrants.

The **4-1/2" American-Darling MARK 73-5** hydrant has all the features you expect from a high quality fire hydrant. The epoxy primer and polyurethane top coat system on external surfaces of the upper barrel provide a durable, high-gloss finish that will continue to look good for years without repainting. The all bronze seat and bronze drain ring assure that the **4-1/2" American-Darling MARK 73-5** hydrant is easily serviced.

### Optional UL-FM in Allowable Configurations

The **4-1/2" American-Darling MARK 73-5** hydrant is UL Listed by UL as meeting their standard UL 246, latest edition. FM Approvals has approved the **4-1/2" American-Darling MARK 73-5**. Both UL and FM Approvals require that we consistently manufacture and test our hydrants in compliance with their stringent requirements. AFC works with these agencies to insure all requirements are met and all credentials are maintained.

# 4-1/2" AMERICAN-DARLING® MARK 73-5 DIMENSIONS



| Depth of Trench | Length of Lower Rod |
|-----------------|---------------------|
| 2' -0"          | 21.50"              |
| 2' -6"          | 27.50"              |
| 3' -0"          | 33.50"              |
| 3' -6"          | 39.50"              |
| 4' -0"          | 45.50"              |
| 4' -6"          | 51.50"              |
| 5' -0"          | 57.50"              |
| 5' -6"          | 63.50"              |
| 6' -0"          | 69.50"              |
| 6' -6"          | 75.50"              |
| 7' -0"          | 81.50"              |
| 7' -6"          | 87.50"              |
| 8' -0"          | 93.50"              |
| 8' -6"          | 99.50"              |
| 9' -0"          | 105.50"             |
| 9' -6"          | 111.50"             |
| 10' -0"         | 117.50"             |
| 10' -6"         | 123.50"             |
| 11' -0"         | 129.50"             |
| 11' -6"         | 135.50"             |
| 12' -0"         | 141.50"             |
| 12' -6"         | 147.50"             |
| 13' -0"         | 153.50"             |
| 13' -6"         | 159.50"             |
| 14' -0"         | 165.50"             |
| 14' -6"         | 171.50"             |
| 15' -0"         | 177.50"             |
| 15' -6"         | 183.50"             |
| 16' -0"         | 189.50"             |
| 16' -6"         | 195.50"             |
| 17' -0"         | 201.50"             |
| 17' -6"         | 207.50"             |
| 18' -0"         | 213.50"             |
| 18' -6"         | 219.50"             |
| 19' -0"         | 225.50"             |
| 19' -6"         | 231.50"             |

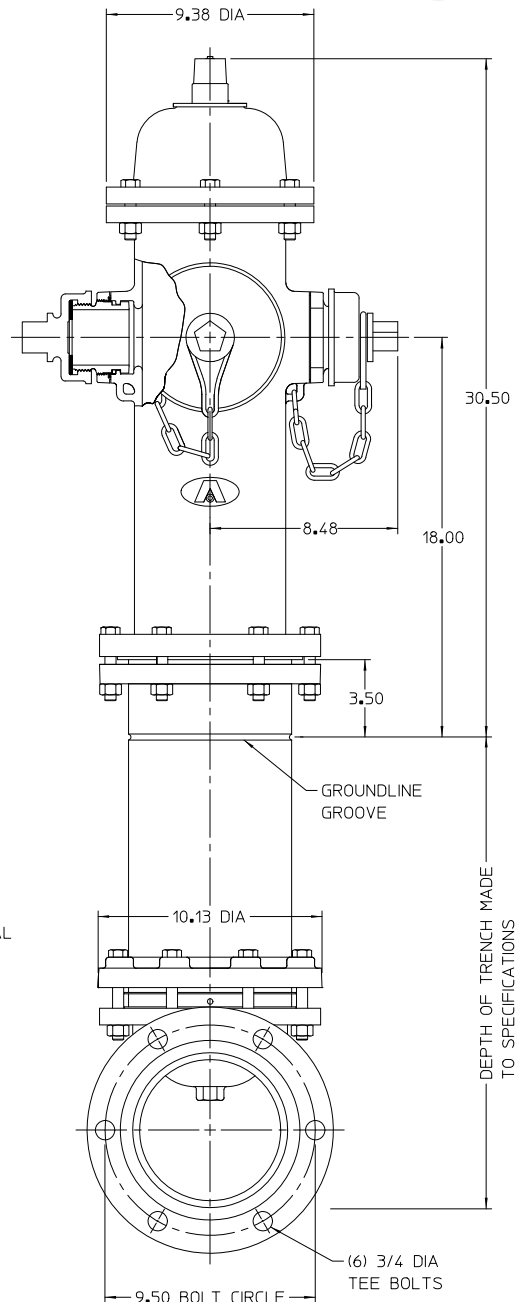
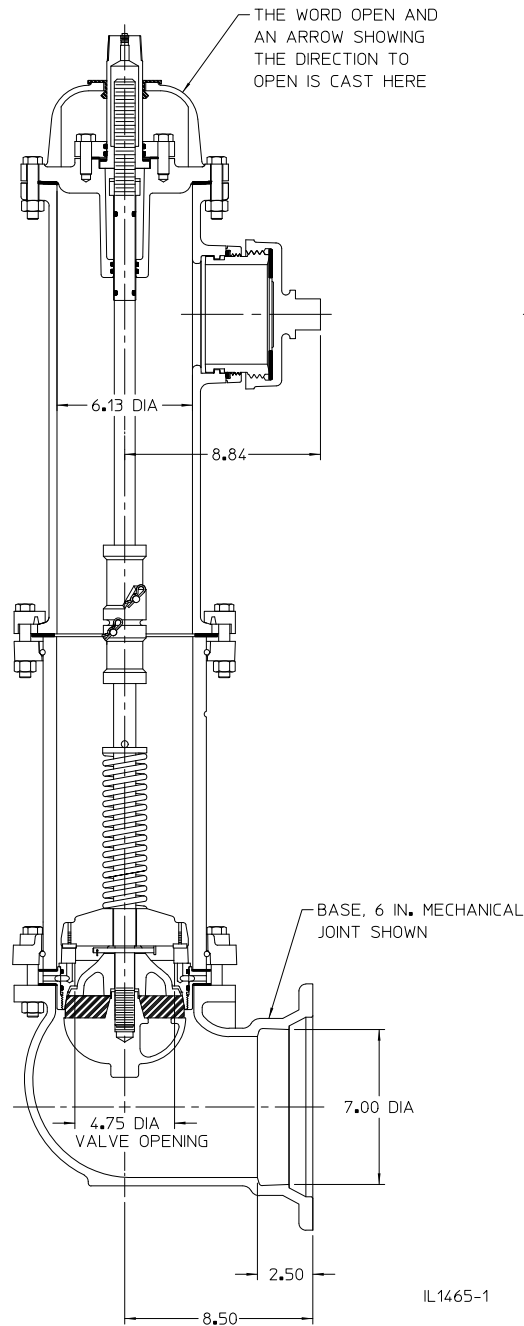

IL1465-1

## NOTES:

1. Depth of trench is the nominal distance from ground line to bottom of connecting pipe.
2. Size and shape of nut on operating nut and cap, threading on nozzles and caps, and the direction of opening made to specifications.
3. Cap chains are not furnished unless specified.
4. Working pressure 250 psig, test pressure 500 psig.
5. Hydrant meets or exceeds the ANSI/AWWA C502 standard.
6. Upper barrel can be rotated 360 degrees.
7. UL Listed and Approved by FM Approvals at 250 psig in allowable configurations.
8. Certified to NSF/ANSI/CAN 61 and NSF/ANSI/CAN 372.

# 4-1/2" AMERICAN-DARLING® MARK 73-5 DIMENSIONS, OPTIONAL BASES

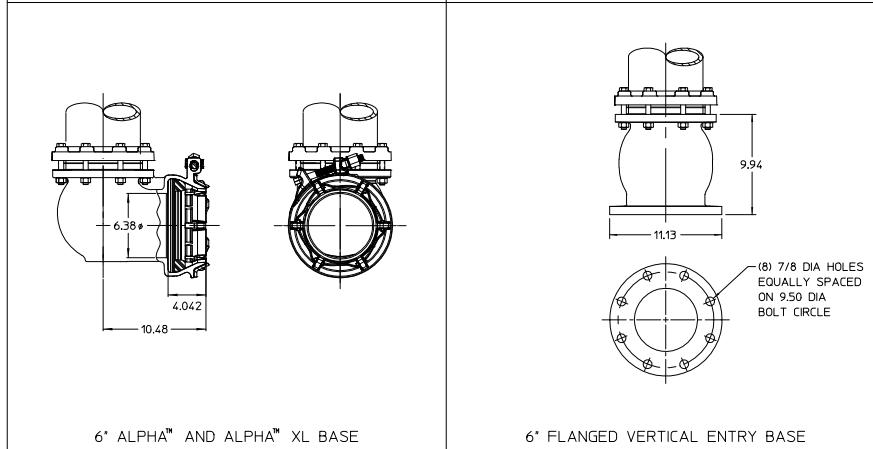
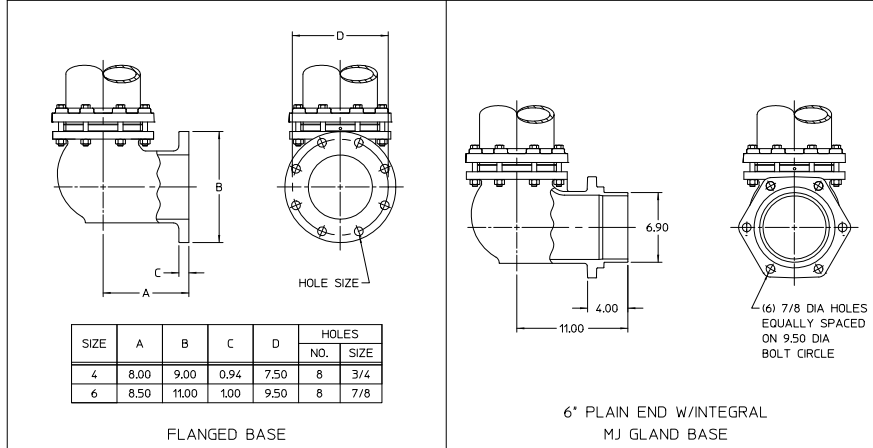
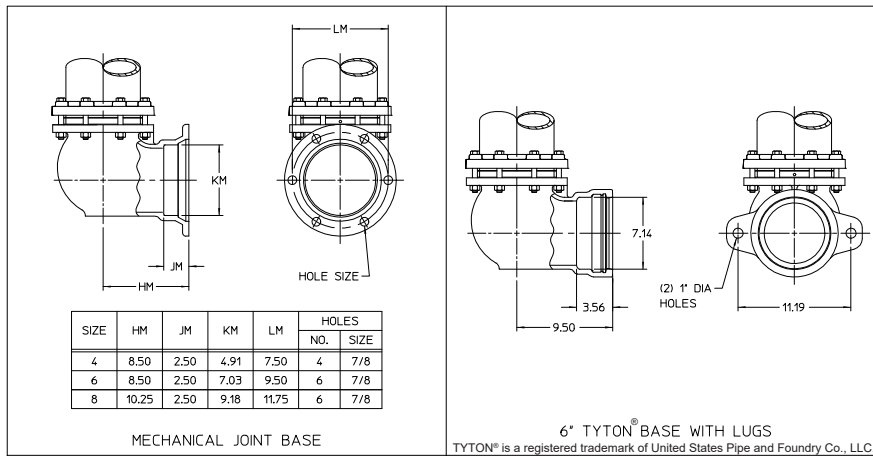

IL1473-2A

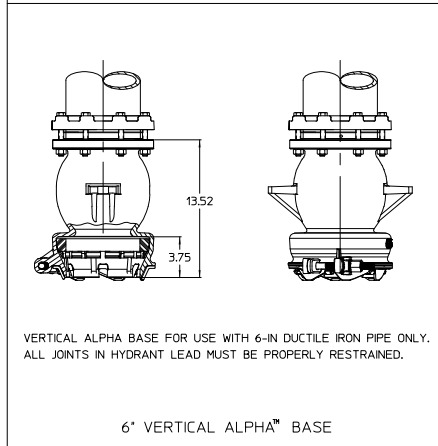

ALPHA™ is a trademark of Romac Industries, Inc. (U.S. Patent 8,894,100)

## 4-1/2" AMERICAN-DARLING® MARK 73-5 OPERATING NUT SIZES



**Square "A"**

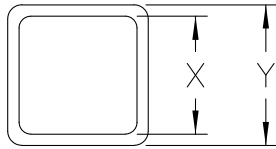

IL1071-3

**Pentagon "B"**

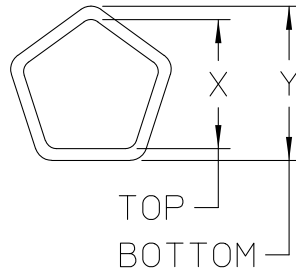

**Hexagon "C"**

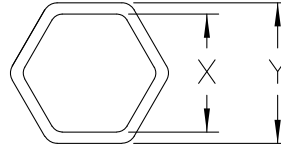

**Triangle "D"**

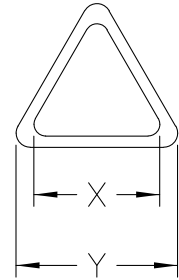

**NOTES:**

1. Operating nut furnished L.H. opening (counterclockwise) or R.H. (clockwise)
2. Cap nuts 1.125 high.

| Nut Shape    | American-Darling Nut No. | X     | Y     |
|--------------|--------------------------|-------|-------|
| Square "A"   | A-1                      | .750  | .812  |
|              | A-2                      | .750  | .875  |
|              | A-3                      | .812  | .875  |
|              | A-8                      | .875  | .938  |
|              | A-9                      | .875  | 1.000 |
|              | A-12                     | .938  | 1.000 |
|              | A-13                     | .938  | 1.062 |
|              | A-16                     | 1.000 | 1.062 |
|              | A-17                     | 1.062 | 1.125 |
|              | A-19                     | 1.125 | 1.188 |
|              | A-23                     | 1.188 | 1.188 |
|              | A-24                     | 1.188 | 1.250 |
|              | A-38                     | .750  | .750  |
| A-41         | 1.125                    | 1.125 |       |
| Pentagon "B" | B-2                      | 1.000 | 1.000 |
|              | B-3                      | 1.000 | 1.062 |
|              | B-5                      | 1.062 | 1.125 |
|              | B-11                     | 1.125 | 1.188 |
|              | B-12                     | 1.125 | 1.312 |
|              | B-13                     | 1.125 | 1.375 |
|              | B-18                     | 1.188 | 1.250 |
|              | B-23                     | 1.250 | 1.250 |
|              | B-24                     | 1.250 | 1.312 |
|              | B-26                     | 1.250 | 1.375 |
|              | B-27                     | 1.250 | 1.500 |
|              | B-31                     | 1.312 | 1.375 |

## 4-1/2" AMERICAN-DARLING® MARK 73-5 OPERATING NUT SIZES



| Nut Shape    | American-Darling Nut No. | X     | Y     |
|--------------|--------------------------|-------|-------|
| Pentagon "B" | B-34                     | 1.375 | 1.438 |
|              | B-35                     | 1.375 | 1.500 |
|              | B-36                     | 1.375 | 1.750 |
|              | B-41                     | 1.438 | 1.500 |
|              | B-49                     | 1.500 | 1.562 |
|              | B-50                     | 1.500 | 1.625 |
|              | B-54                     | 1.562 | 1.625 |
|              | B-69                     | 1.125 | 1.250 |
|              | B-74                     | 1.375 | 1.375 |
|              | B-75                     | .812  | .875  |
|              | B-76                     | 1.812 | 1.875 |
| Hexagon "C"  | C-1                      | 1.062 | 1.125 |
|              | C-2                      | 1.125 | 1.188 |
|              | C-5                      | 1.188 | 1.188 |
|              | C-6                      | 1.188 | 1.250 |
|              | C-8                      | 1.312 | 1.375 |
|              | C-10                     | 1.375 | 1.438 |
|              | C-15                     | 1.438 | 1.500 |
|              | C-18                     | 1.500 | 1.500 |
|              | C-22                     | 1.250 | 1.312 |
|              | C-23                     | 1.000 | 1.000 |
| Triangle "D" | D-1                      | 1.375 | 1.375 |
|              | D-2                      | 1.375 | 1.375 |
|              | D-3                      | 1.750 | 1.812 |

**4-1/2" AMERICAN-DARLING® MARK 73-5 WEIGHTS  
WITH 6 INCH MECHANICAL JOINT BASE AND ACCESSORIES  
(GLAND, GASKET AND HARDWARE)**



| TWO HOSE AND ONE PUMPER NOZZLE |              |
|--------------------------------|--------------|
| TRENCH DEPTH                   | WEIGHT (LBS) |
| 3'-0"                          | 315          |
| 3'-6"                          | 335          |
| 4'-0"                          | 355          |
| 4'-6"                          | 375          |
| 5'-0"                          | 395          |
| 5'-6"                          | 415          |
| 6'-0"                          | 435          |
| 6'-6"                          | 455          |
| 7'-0"                          | 475          |
| 7'-6"                          | 495          |
| 8'-0"                          | 515          |
| 8'-6"                          | 535          |
| 9'-0"                          | 555          |
| 9'-6"                          | 575          |
| 10'-0"                         | 595          |

**Add or deduct 20 lbs for each 6 in. variance in bury depth.**

**Add for:** 6 in. Flanged base - 30 lbs  
**Deduct for:** Two hose nozzles only - 25 lbs



# 4-1/2" AMERICAN-DARLING® MARK 73-5 FRICTION LOSS CURVE



4-1/2" American-Darling Mark 73-5 Hydrant  
Flow vs. Friction Loss

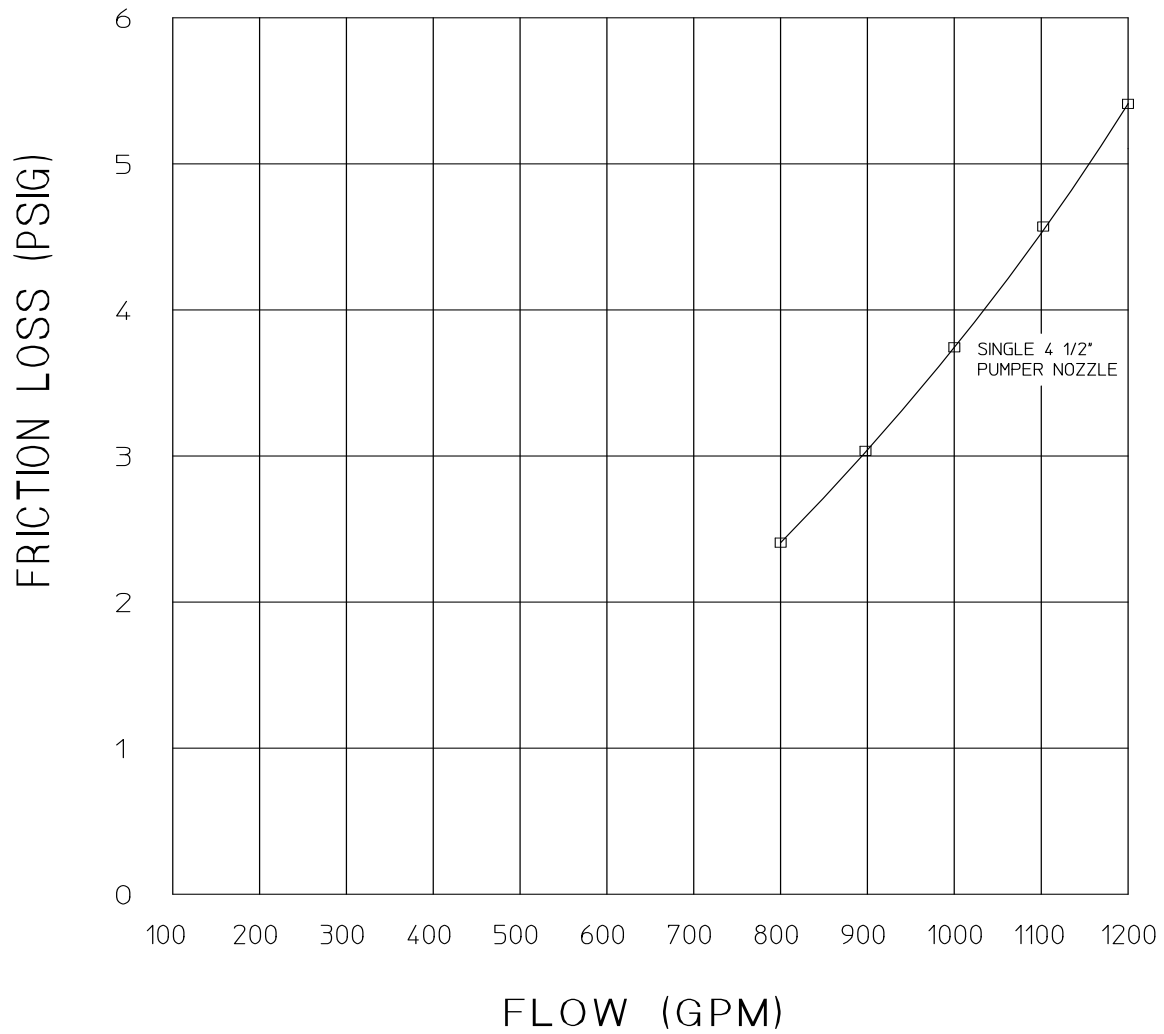



**AMERICAN Flow Control®**  
**4-1/2" AMERICAN-DARLING® MARK 73-5 FIRE HYDRANT**  
 SUBMITTAL SHEET

|   |   |  |
|---|---|--|
| City Specification: _____ Quantity: _____   |   |  |
| Direction to Open: <input type="checkbox"/> Left (C.C.W.) <input type="checkbox"/> Right (C.W.)   |   |  |
| Operating Nut Size: _____ Shape _____ American Darling No. (If Known) _____   |   |  |
| <b>Nozzles</b>  |   |  |
| <b>Configuration: (Check One)</b>   | <b>Pumper Nozzle:</b>   | <b>Hose Nozzle:</b>  |
| <input type="checkbox"/> Two Hose, One Pumper<br><input type="checkbox"/> Two Hose<br><input type="checkbox"/> One Pumper   | Storz:                   4 in.       5 in.<br>National Std <input type="checkbox"/> Yes <input type="checkbox"/> No<br>Size _____<br>_____ Pitch Dia x _____ T.P.I.<br>_____ O. D.<br><br>American-Darling Thread (If Known)<br>_____ | National Std <input type="checkbox"/> Yes <input type="checkbox"/> No<br>Size _____<br>_____ Pitch Dia x _____ T.P.I.<br>_____ O. D.<br><br>American -Darling Thread (If Known)<br>_____ |
| Nozzle Cap Chains: <input type="checkbox"/> Yes <input type="checkbox"/> No   |   |  |
| Depth of Trench (Groundline to Bottom of Pipe):   |   |  |
| Base Connection: (Check One)  |   |  |
| <input type="checkbox"/> 4" MJ <input type="checkbox"/> 6" MJ <input type="checkbox"/> 8" MJ <input type="checkbox"/> 6" Class 125 Flange <input type="checkbox"/> 6" TYTON®<br><input type="checkbox"/> 6" Flanged Vertical Entry <input type="checkbox"/> 6" ALPHA™ <input type="checkbox"/> 6" ALPHA™ XL <input type="checkbox"/> 6" ALPHA™ Vertical Entry |   |  |
| Paint Color: _____  |   |  |
| UL Listed, FM Approved: <input type="checkbox"/> Yes <input type="checkbox"/> No  |   |  |
| Other Requirements: (List)  |   |  |

**AMERICAN Flow Control**  
 American-Darling & Waterous  
 A Division of AMERICAN

**NOTES:**

1. Meets or exceeds requirements of ANSI/AWWA C502, latest revision, with 250 psig rated working pressure.
2. UL Listed and Approved by FM Approvals at 250 psig in allowable configurations.
3. Certified to NSF/ANSI/CAN 61 and NSF/ANSI/CAN 372.
4. TYTON® is a registered trademark of United States Pipe and Foundry Co., LLC.
5. ALPHA™ is a trademark of Romac Industries, Inc. (U.S. Patent 8,894,100)

## 4-1/2" AMERICAN-DARLING® MARK 73-5 INSTALLATION



This instruction is issued as a recommendation to the customer for the proper use of the AMERICAN Flow Control manufactured fire hydrants. AMERICAN recommends you follow the general Inspection and Installation guidelines outlined in AWWA Manual M17 for *Installation, Field Testing, and Maintenance of Fire Hydrants* and/or as recommended below. **WARNING: Special care should be taken in the installation, inspection and repair of pressure containing devices such as valves and hydrants. FAILURE TO FOLLOW PROPER PRACTICE AND GUIDELINES CAN RESULT IN SERIOUS INJURY OR DEATH. High pressure and water hammer, due to rapid opening or closing of a hydrant or valve, can also cause major damage to the hydrant, valve, water main, fire hose, or other attached equipment.**

### Receiving Inspection

On receipt, inspect for direction of opening, correct nozzle threads and operating nuts and shipping damage.

Report any problems to carrier, note on bill of lading and have the driver sign your copy.

### Installation

1. When hydrants are received, they should be handled carefully to avoid breakage and damage. Keep hydrants closed until they are installed. Protect stored hydrants from the elements.
2. **Before installation of hydrant, clean piping, base and drain ring of hydrant of any rocks, sand and/or foreign material. Check for loose bolts at base, ground line and cover. Tighten if necessary to 80 ft-lbs.**
3. Hydrants shall be located as shown or as directed and in a manner to provide complete accessibility, and also in such a manner that the possibility of damage from vehicles or injury to pedestrians will be minimized. Locate hydrants as detailed in AWWA M17 and/or in accordance with applicable fire codes, the requirements of local fire authority, or the applicable municipal design standard.
4. All hydrants shall stand plumb and shall have their nozzles parallel with or at right angles to the curb, with the pumper nozzle facing the curb, except that hydrants having two hose nozzles 90° apart shall be set with each nozzle facing the curb at the angle of 45°. Hydrants shall be set to the established grade, with nozzles at least 18 inches above the ground, as shown or as directed by the engineer.
5. It is recommended practice to install an auxiliary or secondary gate valve in the lateral between the hydrant and the main to permit inspection or repair of the hydrant without shutting down mains. The use of AMERICAN Flow Control Series 2500 Resilient Wedge Gate Valves are recommended.
6. On traffic hydrants, surrounding soil must be adequately compacted around the barrel to support the lower barrel against transferring the force of a vehicular impact to the base. If the soil is too sandy and will not support the loads, pour a concrete pad around the barrel at or near the ground line at least 6 inches thick and 36 inches in diameter for barrel support.
7. Whenever a hydrant is set in soil that is pervious, drainage shall be provided at the base of the hydrant by placing coarse gravel or crushed stone mixed with coarse sand, from the bottom of the trench to at least 6 inches above the drain opening in the hydrant and to a distance of 1 foot around the elbow.
8. Whenever a hydrant is set in clay or other impervious soil, a drainage pit 2 feet in diameter and 3 feet deep shall be excavated below each hydrant and compactly filled with coarse gravel or crushed stone mixed with coarse sand under and around the elbow of the hydrant and to a level of 6 inches above the drain opening.
9. Where there is a high ground water level or other conditions which prevent the use of hydrants with drains, or as specified, "non-draining" hydrants should be used. Hydrants of this type are provided with either a solid seat and/or plugged drains and are marked to pump after use. This is especially important to avoid damage to the hydrant in areas where freezing temperatures are likely. Non-draining hydrants should be checked upon installation and during semi-annual inspections to make sure the hydrant stays dry inside the lower and upper barrel.
10. Restrain hydrant movement with appropriate thrust blocking or restrained joint to prevent pipe and/or joint separation. If a concrete thrust block is installed, care should be taken to prevent blocking the hydrant drains if they are to remain operable.
11. When first installed, the hydrant should be operated from full closed to full open position and back to make sure no obstructions are present.
12. After the line, as well as the hydrant, have been hydrostatically tested, the hydrant should be flushed and checked for proper drainage, if applicable.



## 4-1/2" AMERICAN-DARLING® MARK 73-5 TESTING

AMERICAN Flow Control recommends you follow the General Inspection and Installation Guidelines outlined in AWWA Manual M17 for Installation, Field Testing, and Maintenance of Fire Hydrants and/or as recommended below. ANSI/AWWA C502 permits dry barrel hydrants with unplugged drain outlets to have an allowable leakage of 5 fluid oz/min (0.25 mL/s) through the drain valve. Therefore, the hydrant should not be opened at the same time that the water main is tested. The auxiliary valve should be closed during water main tests (see ANSI/AWWA C600). If it is necessary to test the hydrant and water main at the same time, the installer may elect to temporarily plug the drain outlets by installing a non-draining seat. **WARNING: Special care should be taken in the installation, inspection and repair of pressure containing devices such as valves and hydrants. FAILURE TO FOLLOW PROPER PRACTICE AND GUIDELINES CAN RESULT IN SERIOUS INJURY OR DEATH. High pressure and water hammer, due to rapid opening or closing of a hydrant or valve, can also cause major damage to the hydrant, valve, water main, fire hose, or other attached equipment.** After the hydrant is installed and, when possible, before backfilling (and after pressure testing the water main), the hydrant should be tested as follows:

### Pressure Test at Main Pressure

**WARNING: FAILURE TO RELIEVE PRESSURE CAN RESULT IN THE CAP BLOWING OFF, CAUSING INJURY OR DEATH.**

1. Remove an outlet nozzle cap and open the hydrant valve enough turns to close the drain. Allow the hydrant to fill until water is at the bottom of the outlet nozzle.
2. Replace the outlet nozzle cap and leave it loose to permit all air to escape.
3. After all air has escaped, tighten the outlet nozzle cap.
4. Open the hydrant completely. (Opening the hydrant fully before all the air has escaped will compress the air and cause a safety hazard.)
5. Check for leakage at all joints and outlet nozzles.
6. If leakage is noted, safely repair or replace the necessary components or the entire hydrant using the instructions found in this publication.
7. Repeat the test until results are satisfactory.

### Pressure Test at Pressures Above Main Pressure

**WARNING: FAILURE TO RELIEVE PRESSURE CAN RESULT IN THE CAP BLOWING OFF, CAUSING INJURY OR DEATH.**

1. Connect a pressure test pump to one of the hydrant's outlet nozzles.
2. Open an outlet nozzle cap. Open the hydrant valve a few turns until the drain is sealed. Allow the hydrant to fill until the water level is at the bottom of the outlet nozzle.
3. After all the air has escaped, tighten the outlet nozzle cap.
4. Open the hydrant completely.
5. Close the auxiliary valve.
6. Safely pump up to the test pressure but do not exceed the rated working pressure of the hydrant or system components.
7. Check for leakage at all joints and outlet nozzles.
8. Safely repair hydrant, if necessary, using the instructions found in this publication.
9. Repeat the test until results are satisfactory.
10. Relieve test pump pressure and close the hydrant. Open the auxiliary valve.

## 4-1/2" AMERICAN-DARLING® MARK 73-5 TESTING



### Drainage Test for Dry Barrel Hydrants(Draining -Type)

**WARNING: FAILURE TO RELIEVE PRESSURE CAN RESULT IN THE CAP BLOWING OFF, CAUSING INJURY OR DEATH.**

1. Following the pressure test, close the hydrant main valve with water in the barrel.
2. Carefully remove one outlet nozzle cap and place the palm of one hand over the outlet nozzle opening.
3. Drainage should be sufficiently rapid to create a noticeable suction.
4. If the hydrant fails the drainage test, replace and tighten the nozzle cap, partially open the hydrant (1 or 2-turns) with the outlet nozzle caps on to create a pressure that will flush and clear the drain assembly. If this fails to restore proper drainage, then the drain assembly should be removed and inspected. If the drain assembly is clear, then the problem may be that the drain outlets are plugged outside the hydrant.

### Placing a Hydrant Into Service

1. After testing and backfilling, the hydrant should be safely flushed and tested to be sure that it is bacteriologically safe before it is put into service.
2. Tighten the outlet nozzle caps so they will not be excessively tight, but tight enough to prevent their removal by hand.
3. Clean the hydrant exterior to remove dirt accumulated during installation. Touch up any areas where factory coating was damaged during handling or installation. Use an appropriate top coating or contact factory for touch-up coatings.

## 4-1/2" AMERICAN-DARLING MARK 73-5 OPERATION, INSPECTION, AND MAINTENANCE

### Operation

AMERICAN Flow Control recommends you follow the general Inspection and Installation guidelines outlined in AWWA Manual M17 for Installation, Field testing, and Maintenance of Fire Hydrants and/or as recommended below. The thrust bearing hydrant requires a minimum of torque to operate. **WARNING: Special care should be taken in the installation, inspection and repair of pressure containing devices such as valves and hydrants. FAILURE TO FOLLOW PROPER PRACTICE AND GUIDELINES CAN RESULT IN SERIOUS INJURY OR DEATH. High pressure and water hammer, due to rapid opening or closing of a hydrant or valve, can also cause major damage to the hydrant, valve, water main, fire hose, or other attached equipment.** It is possible to damage the hydrant by forcing it beyond its limits of travel with excess torque; therefore:

1. Check direction of opening as marked on the hydrant cover.
2. Make sure hydrant is in closed position. Slowly remove nozzle cap to relieve any built up pressure. **WARNING: FAILURE TO RELIEVE PRESSURE CAN RESULT IN THE CAP BLOWING OFF, CAUSING INJURY OR DEATH.**
3. To open, turn the operating nut until the main valve is fully open and the travel stop nut limits further opening. **Do not force the hydrant in the opening direction beyond fully-open as indicated by sudden resistance to turning.** If water does not flow when the hydrant is open, it is probably due to a closed valve upstream from the hydrant. Always open the hydrant completely, never only partially. A hydrant that is partially open will allow pressurized flow through the drain valve, which may wash away the soil from the area surrounding the base, or the partially open main valve may trap small stones or other debris between the valve seal and seat.
4. To close, turn the operating nut until the valve stops the flow. **It is not necessary to close this style of hydrant with great force.** Once the flow has stopped, turn the operating nut in the opening direction about 1/4 turn to take the strain off the operating parts of the hydrant. If the hydrant does not shut off completely, do not attempt to force the hydrant to close. Debris and small stones may be trapped in the valve seat and may be preventing the hydrant from closing. Partially open and close the hydrant several times to help dislodge the debris. If this does not work, safely remove the hydrant operating rod assembly, remove the debris and repair as detailed in subsequent sections of this manual.



### Inspection

1. It is recommended that hydrants be inspected twice per year to ensure their satisfactory operation. After each use (especially in cold weather) hydrants should be specifically inspected for drainage.
2. Routine inspection should cover the points outlined in AWWA Manual M17 and include (but not be limited to) the following points:
  - a. External inspection of paint, caps, chains, etc.
  - b. Checking traffic type hydrants for damage to the breakaway feature.
  - c. Using a listening device to check the main valve for leakage.
  - d. Statically testing the hydrant to look for leakage at gaskets, caps, O-rings and drains.
- e. Verifying the hydrant drains properly.
- f. Cycling the hydrant from full open to full close.
- g. Ensuring hydrant is properly lubricated at operating mechanism and nozzle cap threads.
3. At time of inspection, flush the hydrant to remove any foreign material from the hydrant and the lateral. If necessary, flush the drains by filling the hydrant and then cycling open the main valve two times to force water out of the drains under pressure. If the hydrant is non-draining type, pump water out after flushing.

### Maintenance

**AMERICAN Flow Control strongly recommends that you follow routine maintenance on fire hydrants as outlined in AWWA Manual M17 for Installation, Field Testing, and Maintenance of Fire Hydrants. The ease of operation and the frequency of repair depends on the condition of the water system and the maintenance given. Dirt, gravel and other foreign material in the hydrant may prevent it from closing or draining properly, which may result in damage to the hydrant main valve. Under most operating conditions AMERICAN Flow Control recommends semi-annual lubrication and inspection of fire hydrants.**

**Note: Where grease is specified, use an AMERICAN Flow Control recommended food grade grease.**

1. Twice per year, open the hydrant completely and flush for several minutes. Open and close valve to make sure it works properly, and check for leaks.
2. Remove a cap and verify that the hydrant is draining properly. After the main valve is closed, the water in the hydrant should drain rapidly. If it does not, the drain ports may be clogged. To clear drain ports, install nozzle cap, and tighten until water tight, then open hydrant two or three turns for several minutes. This will leave drain port partially open and permit water pressure to wash out the obstruction. If this method is unsuccessful, remove the operating rod assembly and clean the drain mechanism. If neither of above methods permits water to drain, it indicates that the drainage area around the hydrant base should be rebuilt.
3. If it is necessary to add lubricant, turn operating nut back from tight closed position until it turns freely, then remove pipe plug in top of operating nut and add food grade grease into operating nut. **DO NOT OVER PRESSURE LUBRICANT OR OVERFILL HYDRANT WITH LUBRICANT. FAILURE TO FOLLOW THESE INSTRUCTIONS WILL RESULT IN HARD OPERATION OF THE HYDRANT. SHOULD HARD OPERATION OCCUR REFER TO "TROUBLE SHOOTING GUIDE" DETAILED IN THIS MANUAL.** Lubricant in easy to squeeze tubes are available from AMERICAN Flow Control. Contact your authorized distributor for purchase.
4. Remove all nozzle caps, clean rust or corrosion from threads of nozzles and caps, and replace cap gaskets if necessary. Apply a light coat of grease to nozzle threads before replacing cap.





**WARNING:** Special care should be taken in the installation, inspection and repair of pressure containing devices such as valves and hydrants. **FAILURE TO FOLLOW PROPER PRACTICE AND GUIDELINES CAN RESULT IN SERIOUS INJURY OR DEATH.** High pressure and water hammer, due to rapid opening or closing of a hydrant or valve, can also cause major damage to the hydrant, valve, water main, fire hose, or other attached equipment.

| Problem  | Solution  |
|--|---|
| <ol style="list-style-type: none"> <li>1. Operating nut turns freely but hydrant does not open.</li> <li>2. Hydrant will not shut off or ground around hydrant is highly saturated.</li> </ol> | <ol style="list-style-type: none"> <li>1. Inspect rod coupling for breakage and ensure rod pin is properly installed.</li> <li>2. Close hydrant and remove nozzle cap. Check with listening device to determine if water is passing by main valve. If it is determined that the main valve is leaking, try the following:                         <ol style="list-style-type: none"> <li>a. Flush hydrant in fully open position (watch to see if rocks or other foreign objects flush out of the barrel).</li> <li>b. After flushing for several minutes, shut off the hydrant. Watch for several minutes to see if flow stops. Place hand over open hose nozzle; suction should be felt, indicating hydrant is no longer leaking and drains are working properly.</li> <li>c. If flushing does not solve the problem, it would indicate that something is trapped or has cut the main valve rubber. Safely follow the seat removal instructions to replace the valve. Check threads on bronze seat to be sure that it is not damaged. If threads appear worn or bent, replace the bronze seat.</li> <li>d. If replacing the valve does not stop the leakage, bolting at the hydrant shoe may be loose or the base gasket is damaged. The hydrant must be excavated to make the repair.</li> </ol> </li> </ol> |
| <ol style="list-style-type: none"> <li>3. External leakage is noticed around the operating nut.</li> </ol>   | <ol style="list-style-type: none"> <li>3. This indicates that O-rings are cut or missing. Replace o-rings as referenced in the disassembly and repair instructions.</li> </ol>  |



## Problem

## Solution

- |   |  |
|---|--|
| <p>4. Operating nut is extremely hard to turn.</p> <p>5. Water is dripping around nozzles.</p> <p>6. Hydrant will not drain properly.</p> | <p>4. Try to turn the operating nut. If the nut turns, carefully turn the nut back from a tight closed position until it turns freely. Remove the pipe plug in the top of the operating nut. If necessary, add food grade grease to the operating nut. <b>DO NOT OVERPRESSURE THE LUBRICANT OR OVERFILL THE HYDRANT WITH LUBRICANT. FAILURE TO FOLLOW THESE DIRECTIONS MAY RESULT IN HARD OPERATION OF THE HYDRANT. ALWAYS FULLY OPEN AND CLOSE THE HYDRANT AFTER LUBRICATING.</b> Replace the pipe plug taking care to replace the thread sealant. The hydrant should cycle freely. If this does not solve the problem, remove the operating nut. Verify the hydrant has not been over lubricated and inspect the threads of the operating nut and upper rod. Inspect the ball bearing to ensure it is lubricated and is undamaged. Replace and/or lubricate the ball bearing if necessary. If this does not solve the problem, remove the hydrant seat and flush thoroughly, then reassemble.<br/><b>Note: Where grease is specified, use an AMERICAN Flow Control recommended food grade grease.</b></p> <p>5. Close hydrant and remove nozzle cap. Replace cap gasket. Check the nozzle to be sure it is properly installed.</p> <p>6. Check to be sure the water table has not risen too high to allow for drainage. Flush hydrant to be sure drains are clear. Open hydrant slowly several turns while leaving caps firmly in place to ensure hydrant drains are clear. Close hydrant and repeat this procedure. Do this slowly several times. If problem is not corrected, excavate the hydrant to see if concrete or other materials have blocked the drain outlets.</p> |
|---|--|



# 4-1/2" AMERICAN-DARLING® MARK 73-5 PARTS LIST

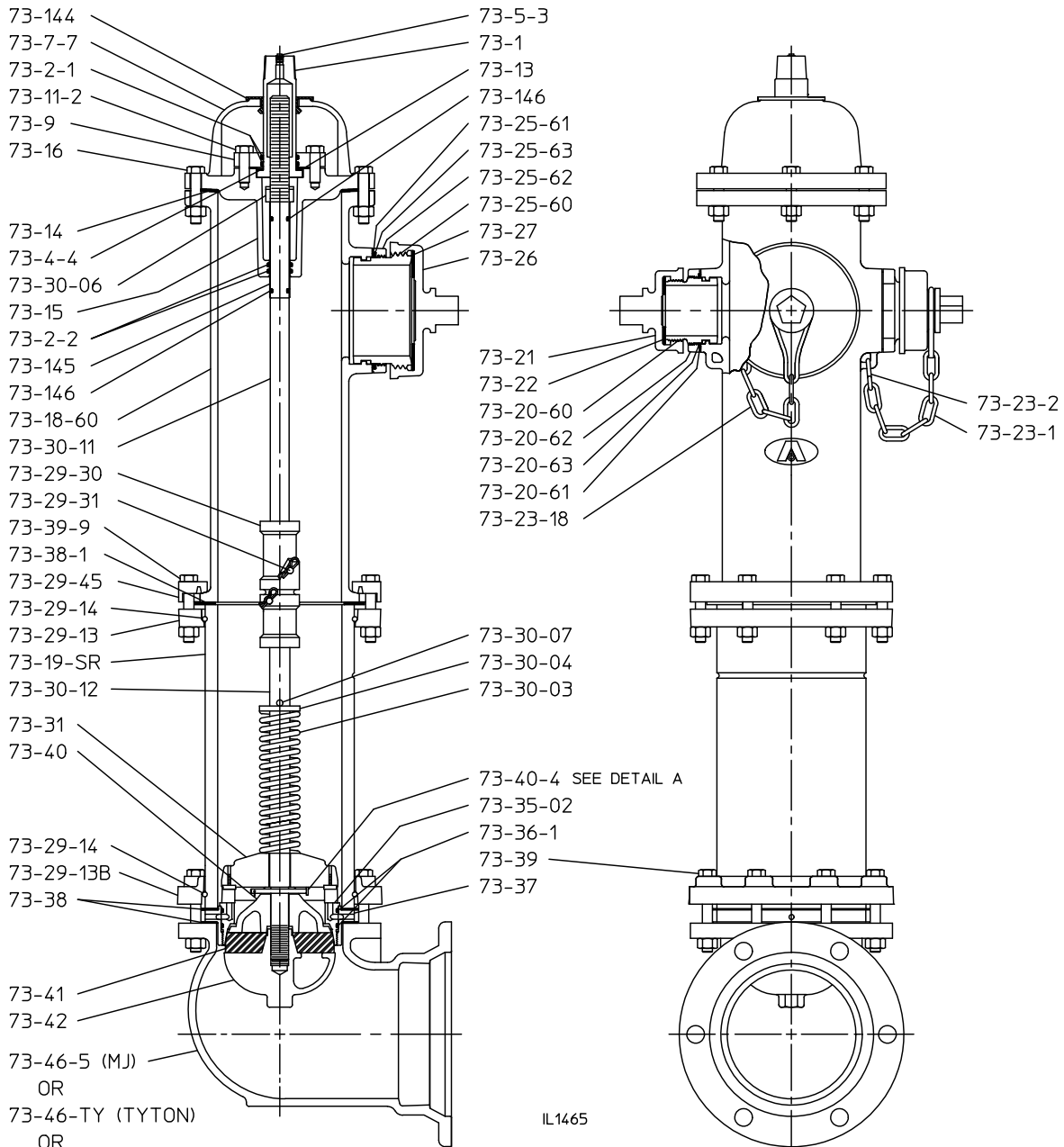

- 73-144
- 73-7-7
- 73-2-1
- 73-11-2
- 73-9
- 73-16
- 73-14
- 73-4-4
- 73-30-06
- 73-15
- 73-2-2
- 73-145
- 73-146
- 73-18-60
- 73-30-11
- 73-29-30
- 73-29-31
- 73-39-9
- 73-38-1
- 73-29-45
- 73-29-14
- 73-29-13
- 73-19-SR
- 73-30-12
- 73-31
- 73-40
- 73-29-14
- 73-29-13B
- 73-38
- 73-41
- 73-42
- 73-46-5 (MJ)
- OR
- 73-46-TY (TYTON)
- OR
- 73-46-2 (FLANGED)
- OR
- 73-46-2A (VERTICAL ENTRY)
- OR
- 73-46-PE (MJ PLAIN END)
- OR
- 73-46-AA (ALPHA™)
- OR
- 73-46-AX (ALPHA™ XL)

- 73-5-3
- 73-1
- 73-13
- 73-146
- 73-25-61
- 73-25-63
- 73-25-62
- 73-25-60
- 73-27
- 73-26
- 73-21
- 73-22
- 73-20-60
- 73-20-62
- 73-20-63
- 73-20-61
- 73-23-18
- 73-23-2
- 73-23-1
- 73-30-07
- 73-30-04
- 73-30-03
- 73-40-4 SEE DETAIL A
- 73-35-02
- 73-36-1
- 73-39
- 73-37

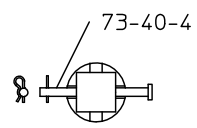

DETAIL A

TOP VIEW OF CLEVIS PIN & CLIP PIN USED TO SECURE HYDRANT VALVE ASSEMBLY

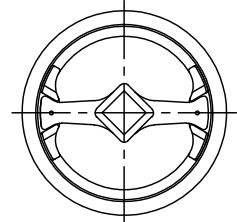

TOP VIEW OF SEAT AND DRAIN LEVER ASSEMBLY

IL1465

## 4-1/2" AMERICAN-DARLING® MARK 73-5 PARTS LIST



| Part No.  | Qty.         | Description                   | Material               |
|-----------|--------------|-------------------------------|------------------------|
| 73-1      | 1            | Operating Nut                 | Bronze                 |
| 73-2-1    | 2            | Cover O-ring                  | Buna N                 |
| 73-2-2    | 2            | Housing O-ring                | Buna N                 |
| 73-4-4    | 1            | Thrust Washer                 | Nylatron               |
| 73-5-3    | 1            | Pipe Plug                     | Stainless Steel        |
| 73-7-7    | 1            | Weather Cover                 | Gray Iron              |
| 73-9      | 1            | Housing Cover                 | Gray Iron              |
| 73-11-2   | 4            | Housing Cover Cap Screw       | Plated Steel           |
| 73-13     | 1            | Housing Cover Gasket          | Fiber                  |
| 73-14     | 1            | Housing Gasket                | Composition Rubber     |
| 73-15     | 1            | Housing                       | Ductile Iron           |
| 73-16     | 6            | Housing Bolt and Nut          | Plated Steel           |
| 73-18-60  | 1            | Upper Barrel                  | Ductile Iron           |
| 73-19-SR  | 1            | Lower Barrel                  | Ductile Iron           |
| 73-20-60  | 2            | Hose Nozzle                   | Bronze                 |
| 73-20-61  | 2            | Hose Nozzle O-ring Seal       | Buna N                 |
| 73-20-62  | 2            | Hose Nozzle Retainer          | Ductile Iron           |
| 73-20-63  | 2            | Hose Nozzle Retainer Washer   | Teflon                 |
| 73-21     | 2            | Hose Cap                      | See Note 8             |
| 73-22     | 2            | Hose Cap Gasket               | Rubber                 |
| 73-23-1   | 1 Per Nozzle | Hose Cap Chain                | Steel                  |
| 73-23-2   | 1 Per Nozzle | S Hook                        | Steel                  |
| 73-23-18  | 1 Per Nozzle | Pumper Cap Chain              | Steel                  |
| 73-25-60  | 1 or 0       | Pumper Nozzle                 | Bronze                 |
| 73-25-61  | 1 Per Nozzle | Pumper Nozzle O-ring Seal     | Buna N                 |
| 73-25-62  | 1 Per Nozzle | Pumper Nozzle Retainer        | Ductile Iron           |
| 73-25-63  | 1 Per Nozzle | Pumper Nozzle Retainer Washer | Teflon                 |
| 73-26     | 1 Per Nozzle | Pumper Cap                    | See Note 8             |
| 73-27     | 1 Per Nozzle | Pumper Cap Gasket             | Rubber                 |
| 73-29-13  | 1            | Barrel Flange                 | Ductile Iron           |
| 73-29-13B | 1            | Base Flange                   | Ductile Iron           |
| 73-29-14  | 2            | Snap Ring                     | Stainless Steel        |
| 73-29-30  | 1            | Rod Coupling                  | Epoxy Coated Gray Iron |
| 73-29-31  | 2            | Rod Coupling Pin and Clip Pin | Stainless Steel        |
| 73-29-45  | 1            | Breakable Flange              | Gray Iron              |
| 73-30-03  | 1            | Spring                        | Stainless Steel        |
| 73-30-04  | 1            | Spring Plate                  | Stainless Steel        |
| 73-30-06  | 1            | Travel Stop Nut               | Bronze                 |
| 73-30-07  | 1            | Spring Plate Pin              | Stainless Steel        |
| 73-30-11  | 1            | Upper Rod                     | Steel                  |
| 73-30-12  | 1            | Lower Rod                     | Steel                  |
| 73-31     | 1            | Drain Lever                   | Bronze                 |
| 73-35-02  | 1            | Hydrant Seat                  | Bronze                 |
| 73-36-1   | 2            | Hydrant Seat O-ring           | Buna N                 |
| 73-37     | 1            | Drain Ring                    | Bronze                 |
| 73-38     | 2            | Drain Ring Gasket             | Composition Rubber     |
| 73-38-1   | 1            | Barrel Gasket                 | Composition Rubber     |
| 73-39     | 8            | Base Bolt and Nut             | Stainless Steel        |

## 4-1/2" AMERICAN-DARLING® MARK 73-5 PARTS LIST



| Part No.  | Qty. | Description                     | Material        |
|-----------|------|---------------------------------|-----------------|
| 73-39-9   | 8    | Barrel Bolt and Nut             | Plated Steel    |
| 73-40     | 1    | Valve Top                       | Ductile Iron    |
| 73-40-1*  | 2    | Valve Top Facing                | Polyethylene    |
| 73-40-2*  | 4    | Facing Screws                   | Steel           |
| 73-40-4   | 1    | Valve Top Clevis and Clip Pin   | Stainless Steel |
| 73-41     | 1    | Hydrant Valve                   | EPDM Rubber     |
| 73-42     | 1    | Valve Bottom                    | Ductile Iron    |
| 73-46-2   | 1    | Flanged Base                    | Ductile Iron    |
| 73-46-2A  | 1    | Vertical Entry Base             | Ductile Iron    |
| 73-46-5   | 1    | Mechanical Joint Base           | Ductile Iron    |
| 73-46-PE  | 1    | Mechanical Joint Plain End Base | Ductile Iron    |
| 73-46-TY  | 1    | TYTON® Base                     | Ductile Iron    |
| 73-46-6AA | 1    | ALPHA™ Restraint Joint Base     | Ductile Iron    |
| 73-46-6AX | 1    | ALPHA™ XL Restraint Joint Base  | Ductile Iron    |
| 73-144    | 1    | Weather Shield                  | Rubber          |
| 73-145    | 1    | Rod Sleeve                      | Bronze          |
| 73-146    | 2    | Sleeve O-ring                   | Buna N          |
| 73-36-1   | 2    | Hydrant Seat O-ring             | Buna N          |

\* parts use in MK73 & MK73-1 only

### Notes

- Size and shape of nut on operating nut and cap, threading on nozzles and caps, and the direction of opening made to specifications.
- Cap chains are not furnished unless specified.
- Working pressure 250 psig. Factory test pressure 500 psig.
- Hydrant meets or exceeds the ANSI/AWWA C502 standard.
- Upper barrel can be rotated 360°.
- UL Listed and Approved by FM Approvals at 250 psig in allowable configurations.
- Certified to NSF/ANSI/CAN 61 and NSF/ANSI/CAN 372.
- National Standard and other common cap configurations are constructed of ductile iron. Other offerings may be constructed of gray cast iron.
- Nominal turns to open is 17 1/2.
- TYTON® is a registered trademark of United States Pipe and Foundry Co., LLC.
- ALPHA™ is a trademark of Romac Industries, Inc. (U.S. Patent 8,894,100)

### MARK 73, 73-1, 73-2 & 73-5 VALVE COMPARISON

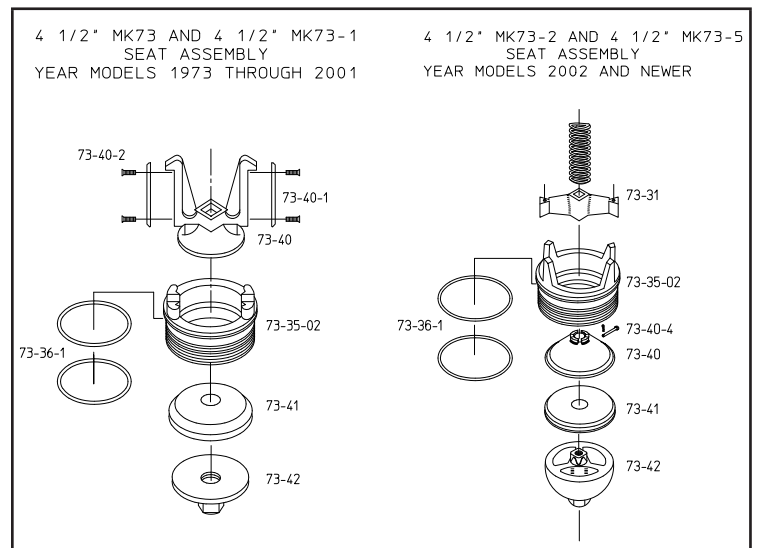

ALPHA restraint joints will accommodate the following pipe types and sizes:

#### ALPHA

- Ductile iron per AWWA C151
- PVC per ASTM D1785 (Schedule 40 and 80)
- PVC per ASTM D2241 (SDR 21)
- PVC per AWWA C900
- HDPE per AWWA C906 (SDR 9, 11, 13.5, and 17)

#### ALPHA XL

- Gray iron (Class A, B, C, and D)

| Nominal Size (in) | ALPHA OD Range (in) | ALPHA XL OD Range (in) |
|-------------------|---------------------|------------------------|
| 6                 | 6.60 - 7.00         | 6.90 - 7.10            |

### Spare Parts

Spare parts are readily available. The following parts may be considered for inventory:

O-ring for housing, O-ring for housing cover, O-ring for nozzles, barrel flange gasket, base flange gasket, main valve seat gasket or O-ring, hydrant valve and cap gaskets.

Traffic model hydrants also include traffic repair kits.

# 4-1/2" AMERICAN-DARLING® MARK 73-5 REPAIR INSTRUCTIONS



## Disassembling the Hydrant

**WARNING:** Special care should be taken in the installation, inspection and repair of pressure containing devices such as valves and hydrants. **FAILURE TO FOLLOW PROPER PRACTICE AND GUIDELINES CAN RESULT IN SERIOUS INJURY OR DEATH.** High pressure and water hammer, due to rapid opening or closing of a hydrant or valve, can also cause major damage to the hydrant, valve, water main, fire hose, or other attached equipment.

### Removing Internal Parts

One person with hand tools and a lightweight seat wrench can quickly remove all the working parts, including hydrant valve, drain lever and hydrant seat. To repair, it is not necessary to excavate American-Darling hydrants; merely remove the internal parts.

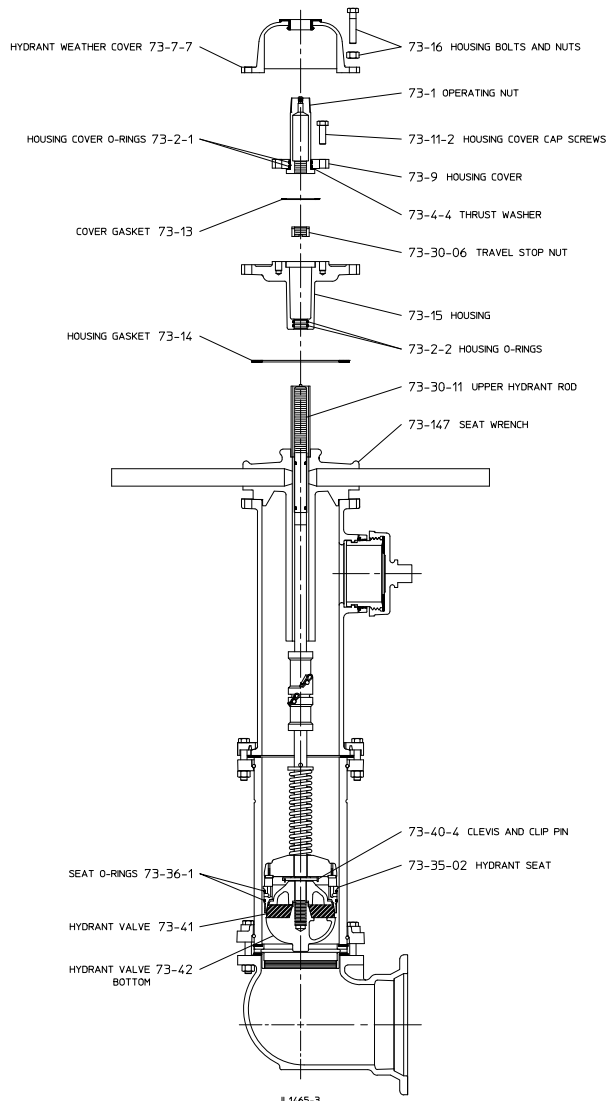

### Directions for Removing Internal Parts of 4-1/2" AMERICAN-DARLING MARK 73-5 Hydrants

1. Shut off water line leading to hydrant making sure the hydrant is not under pressure. **FAILURE TO FOLLOW PROPER PRACTICE AND GUIDELINES CAN RESULT IN SERIOUS INJURY OR DEATH.**
2. Partially open hydrant valve to relieve trapped pressure.
3. Standing to the side of the hydrant and away from the direction of the hydrant cap(s), loosen one of the hose caps to relieve any pressure that may be present in the hydrant barrel. Close hydrant valve. From full open to full close takes approximately 17 1/2 turns.
4. Remove hydrant weather cover (73-7-7) with weather shield by removing two bolts and nuts (73-16).
5. Remove the four housing cover cap screws (73-11-2) on housing cover (73-9).
6. Unscrew and remove operating nut (73-1) from upper hydrant rod (73-30-11) together with housing cover (73-9) and thrust washer (73-4-4).
7. Use top of seat wrench (Part 73-147) to unscrew and remove travel stop nut (73-30-06).
8. Remove remaining housing bolts (73-16) then lift out housing (73-15). Inspect O-rings and replace if necessary. Special care must be taken to avoid damaging O-rings (73-2-2).
9. Place seat wrench over upper hydrant rod (73-30-11) and turn to the left (counterclockwise) to unscrew bronze hydrant seat (73-35-02) and lift out hydrant rod with completely assembled internal working parts attached, including hydrant seat, hydrant valve, drain lever and seat O-rings. Care should be taken never to lean over a hydrant during disassembly.

**NOTE:** When a supply of gaskets and O-rings are available, always install new ones when reassembling the hydrant. Clean dirt from O-ring grooves.

## 4-1/2" AMERICAN-DARLING® MARK 73-5 REPAIR INSTRUCTIONS



### Reassembling the Hydrant

**WARNING:** Special care should be taken in the installation, inspection and repair of pressure containing devices such as valves and hydrants. **FAILURE TO FOLLOW PROPER PRACTICE AND GUIDELINES CAN RESULT IN SERIOUS INJURY OR DEATH.** High pressure and water hammer, due to rapid opening or closing of a hydrant or valve, can also cause major damage to the hydrant, valve, water main, fire hose, or other attached equipment.

1. Thread the valve assembly (parts 73-40, 73-41, 73-42) to the lower hydrant rod. Tighten valve bottom (73-42) to 145 ft-lbs. of torque. Advance slot in the valve top (73-40) to next pin location. On Mark 73 hydrants manufactured prior to 2002 when the hydrant valve is replaced, use a locking compound to secure the valve ball assembly. On Mark 73 hydrants manufactured after 2002, pin the valve ball assembly in place with the clevis and clip pin (73-40-4).
2. Grease the seat O-rings (73-36-1) and lower the parts through the hydrant barrel.
3. When the assembly has made contact with the drain ring (73-37), push the assembly straight down. To avoid cross threading, turn the seat wrench counterclockwise until an ajar is felt. This ajar indicates that the thread starts are properly aligned.
4. Turn the seat wrench clockwise approximately seven turns until it is tight. Pull upward on the rod to ensure it is securely fastened to the drain ring (73-37). Replace the housing gasket (73-14).
5. Grease the threads on the upper hydrant rod (73-30-11) and the O-rings (73-2-2) in the housing.
6. Slip the housing (73-15) over the rod. Note: Special care should be taken to avoid damaging housing O-rings. Bolt up housing using four housing bolts and nuts (73-16) and tighten to approximately 60 ft-lbs.
7. Thread the travel stop nut (73-30-06) onto the upper rod until contact is made with the brass rod sleeve. Tighten the travel stop nut to approximately 30 ft-lbs. Do not overtighten.
8. Put the cover gasket (73-13) in place and then thread the bronze operating nut (73-1) onto the rod.
9. Tighten the operating nut with the operating wrench and put the cover cap screws (73-11-2) in place. Then replace the weather cover (73-7-7) and bolt it up to approximately 60 ft-lbs of torque using the two remaining housing bolts and nuts (73-16).
10. Carefully pressurize the hydrant and check for visual leaks.

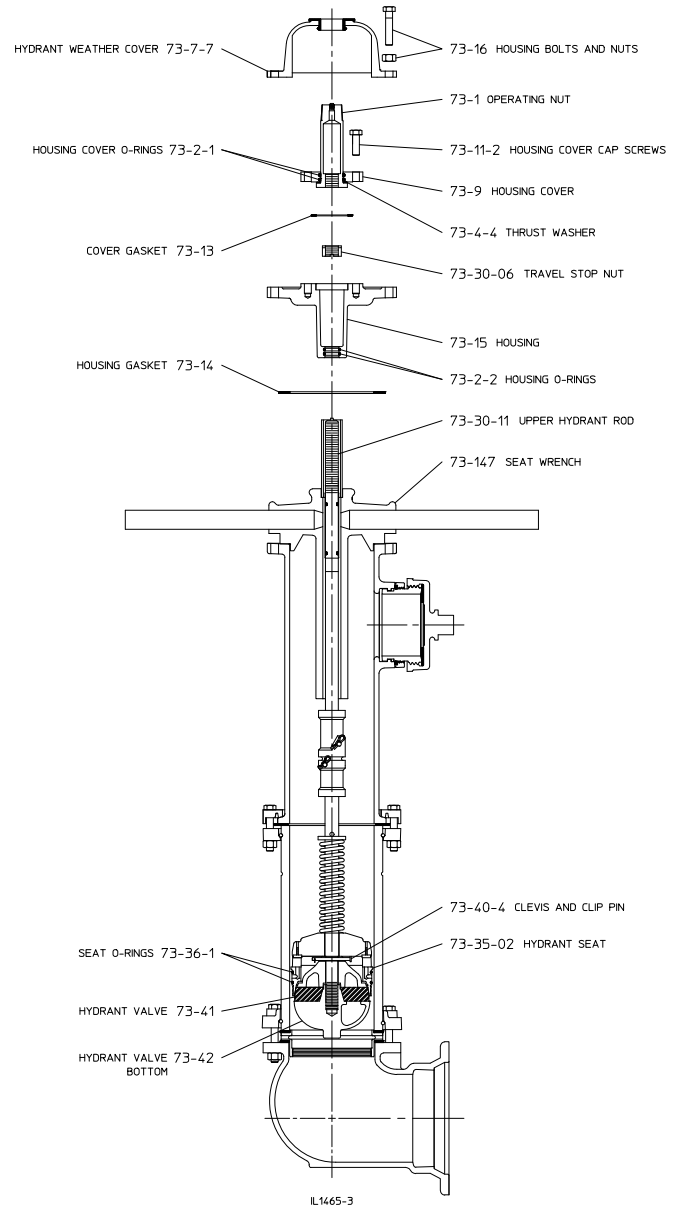

**Note:** Where grease is specified, use an **AMERICAN Flow Control** recommended food grade grease.

## 4-1/2" AMERICAN-DARLING® MARK 73-5 TRAFFIC DAMAGE REPAIR



**WARNING: Special care should be taken in the installation, inspection and repair of pressure containing devices such as valves and hydrants. FAILURE TO FOLLOW PROPER PRACTICE AND GUIDELINES CAN RESULT IN SERIOUS INJURY OR DEATH. High pressure and water hammer, due to rapid opening or closing of a hydrant or valve, can also cause major damage to the hydrant, valve, water main, fire hose, or other attached equipment.**

Should a hydrant be struck by a vehicle such that the upper barrel is separated/broken from the lower barrel, the following procedure should be followed to reassemble the hydrant and make it operational. (A traffic damage repair kit for the specific 4-1/2" AMERICAN-DARLING MARK 73 hydrant is required to perform this procedure.)

1. Although it is possible to repair break features of the hydrant under pressure, the extent of a traffic impact may be unknown. It is considered safe practice to close the auxilliary valve ahead of the hydrant, or use another means to cut off flow and pressure to the hydrant.
2. Inspect the upper barrel (73-18-60) to determine if any of the components are fractured. Traffic impact usually results in a fractured traffic flange (73-29-45), broken or bent flange bolts (73-39-9), a fractured rod coupling (73-29-30) and damage to the gasket between the upper and lower barrels (73-38-1). Should cracking or fracture of any component occur, it should be replaced.
3. The operating nut (73-1) should be rotated to verify that it turns smoothly and easily and that the hydrant rod is centered in the barrel. (Should there be any binding or difficulty in turning the operating nut, the upper barrel should be disassembled and inspected for damaged parts.)
4. Remove the broken coupling (73-29-30) and verify that the upper valve rod (73-30-11) is not bent or damaged.
5. Inspect the lower barrel (73-19-SR) and clean any dirt or debris from the gasket seating surface.
6. Inspect the lower barrel flange (73-29-13) to determine that it will receive the new bolts contained in the traffic damage repair kit.
7. Turn the operating nut while holding the rod to place the hydrant in the full open position; this will extend the upper hydrant rod and ease the replacement of the rod coupling (73-29-30). Remove the broken rod coupling segment from the lower valve rod and verify that the rod end will receive the new coupling.
8. Orient the new rod coupling such that the end with the word "TOP" is placed on the upper hydrant rod such that the hole in the coupling aligns with the half hole on the hydrant rod. Lock coupling in place with stainless steel coupling pin (73-29-31) and clip pin.
9. Lift the upper barrel assembly and position it over the lower barrel while aligning the hydrant rod coupling on the upper hydrant rod with the lower hydrant rod such that the hole in the coupling aligns with the half hole on the lower hydrant rod. Slide the coupling over the lower valve rod and insert coupling pin and clip pin. Lift upper barrel assembly to ensure upper and lower rods are connected to coupling.
10. Turn operating nut in the closing direction which will lower the upper barrel onto the lower barrel. Rotate the hydrant to position the hose and pumper nozzles in the desired orientation to the curb. Be careful to position the barrel gasket (73-38-1) to achieve full coverage of the end faces of the upper and lower barrels. Install new traffic flanges (73-29-45). (Note: While lowering the upper section onto the lower section, a pinch point exists. Keep fingers clear.)
11. After nuts have been started on all bolts, tighten the flange bolts in an alternating pattern to a torque value of between 55 and 60 ft-lbs.
12. Once the hydrant has been reassembled, it is essential that it be operated to determine that it is fully functional via the following procedure.
13. Open the auxiliary or secondary gate valve in the lateral to allow water pressure to the hydrant.
14. The hose and pumper caps should be tightened and the operating nut turned in the open direction. After cracking the valve seat open, the operating nut should rotate freely without binding.

| Traffic Damage Repair Kit Parts |   |                           |
|---------------------------------|---|---------------------------|
| 73-29-31                        | 2 | Rod Coupling and Clip Pin |
| 73-29-30                        | 1 | Breakable Rod Coupling    |
| 73-29-45                        | 2 | Traffic Flange            |
| 73-38-1                         | 1 | Barrel Gasket             |
| 73-39-9                         | 8 | Barrel Bolts and Nuts     |



# 4-1/2" AMERICAN-DARLING® MARK 73 AMLOK NOZZLE REPLACEMENT (FOR HYDRANTS BUILT PRIOR TO 2006)

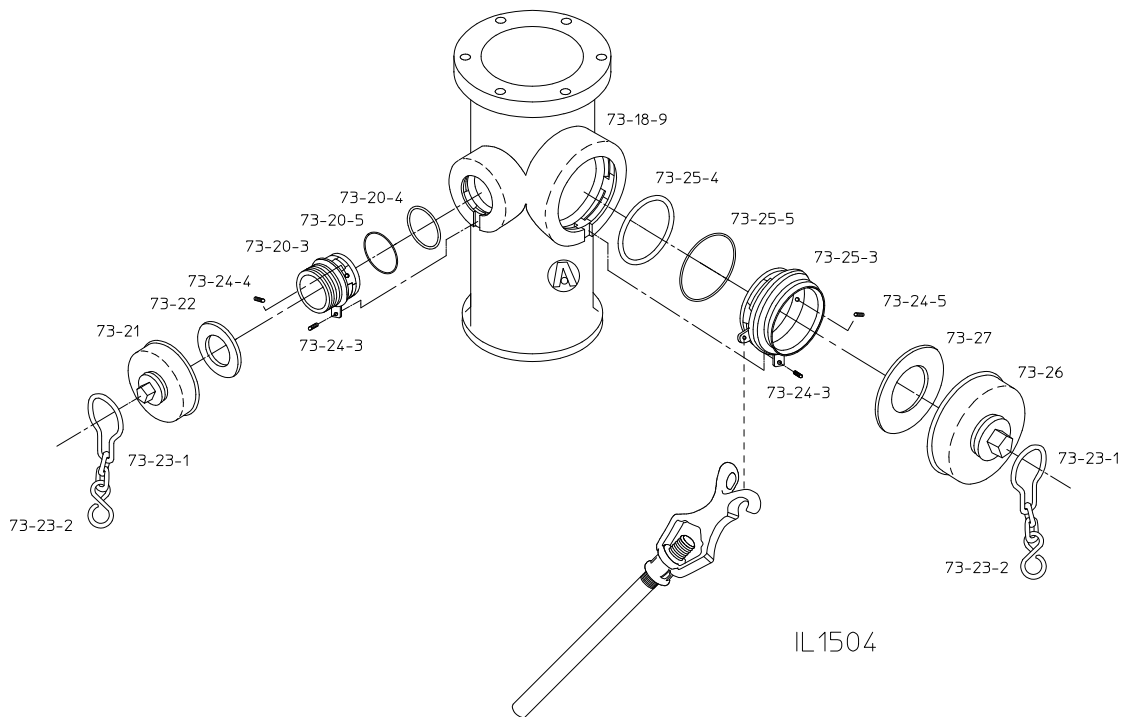

## Amlok Nozzle Replacement

**WARNING: POTENTIAL HYDRANT CAP HAZARD. FAILURE TO RELIEVE PRESSURE CAN RESULT IN THE CAP BLOWING OFF, CAUSING SERIOUS INJURY OR DEATH.** Make sure the auxiliary gate valve in the lateral between the main and the hydrant is closed and that the hydrant is not charged with pressure when removing caps.

### Step 1

Remove the nozzle cap. Remove the 5/16 in. internal set screw (73-24-4 or 73-24-5) with a 5/32 in. hex head allen wrench. Unscrew the 5/16 in. external slotted screw (73-24-3) out of the lug on the nozzle.

### Step 2

Use a universal spanner wrench or AMERICAN Flow Control nozzle wrench to rotate nozzle 1/8 turn clockwise. The nozzle can now be pulled from the hydrant barrel.

### Step 3

Remove O-ring gasket from the nozzle boss. Insert new O-ring and lubricate with food grade grease. Place the nozzle spacer O-ring (73-20-5) or (73-25-5) on the nozzle directly behind the nozzle collar. Place a small amount of lubricant on the plain end of the new nozzle.

**Note: Where grease is specified, use an AMERICAN Flow Control recommended food grade grease.**

### Step 4

Insert the new nozzle into the hydrant barrel with the tapped lug at the 7:30 position. Push the nozzle home and rotate counterclockwise until the nozzle stops.

### Step 5

Insert the 5/16 in. slotted nozzle set screw (73-24-3) into the tapped lug on the nozzle. Tighten the set screw into the slot on the hydrant barrel to remove any play in the nozzle. The top of the set screw should be flush with the surface of the nozzle lug.

### Step 6

Start internal set screw (73-24-4) or (73-24-5) into the threaded hole inside the nozzle. Apply Loctite Thread Sealant #545 or equivalent to the external threads of the set screw. Continue to turn the set screw into the threaded hole with a 5/32 in. hex head allen wrench until it stops. DO NOT TIGHTEN. Replace the nozzle cap and hydrostatically test the hydrant.

# 4-1/2" AMERICAN-DARLING® MARK 73-5 NOZZLE REPLACEMENT MECHANICALLY ATTACHED PUMPER NOZZLE (FOR HYDRANTS BUILT BEGINNING IN 2006)



**WARNING: POTENTIAL HYDRANT CAP HAZARD. FAILURE TO RELIEVE PRESSURE CAN RESULT IN THE CAP BLOWING OFF, CAUSING SERIOUS INJURY OR DEATH.** Make sure the auxiliary gate valve in the lateral between the main and the hydrant is closed and that the hydrant is not charged with pressure when removing caps.

## Removal

1. Remove cap.
2. Place wrench on the retainer so it engages the rounded protrusions and unthread from nozzle.  
Note: Removal of the 4 in. and 5 in. Storz hydrant nozzle requires the use of the hinged pumper nozzle retainer wrench (AMERICAN Flow Control Part No. 82766).
3. Rotate nozzle counterclockwise until the four lugs on the nozzle disengage the recesses in the nozzle section socket which will allow the nozzle to be removed.

## Installation

1. Thread retainer onto the retainer threads of the pumper nozzle.
  2. Place washer over nozzle starting from the end with the four lugs and into the chamfer recess in the retainer.
  3. Grease O-ring and place it over nozzle starting from the end with the four lugs and against the washer. Insert the nozzle/retainer/washer/O-ring subassembly into the socket in the nozzle section. Rotate the subassembly clockwise until it stops with the four lugs on the nozzle fully engaged in the anti-rotation recesses in the socket. If it cannot be rotated, turn the retainer in a direction to allow the nozzle to be inserted further into the socket so the subassembly rotates clockwise against the stops.
  4. Hand tighten the retainer to press O-ring against the face of the socket.
  6. Place the nozzle wrench on the retainer so it engages the rounded protrusions. Tighten the retainer to between 200 – 250 ft-lbs.  
Note: Installation of the 5" Storz hydrant nozzle requires the use of the hinged pumper nozzle retainer wrench (AMERICAN Flow Control Part No. 82766).
  7. Clean rust or corrosion from cap threads and replace cap gasket if necessary. Apply a light coat of grease to the nozzle threads and install the cap.
  8. Cap all nozzles and open the hydrant valve, check the area around the repaired nozzle for leaks.
- NOTE: Where grease is specified, use an AMERICAN Flow Control recommended food grade grease.**

### Mechanically Attached Pumper Nozzle

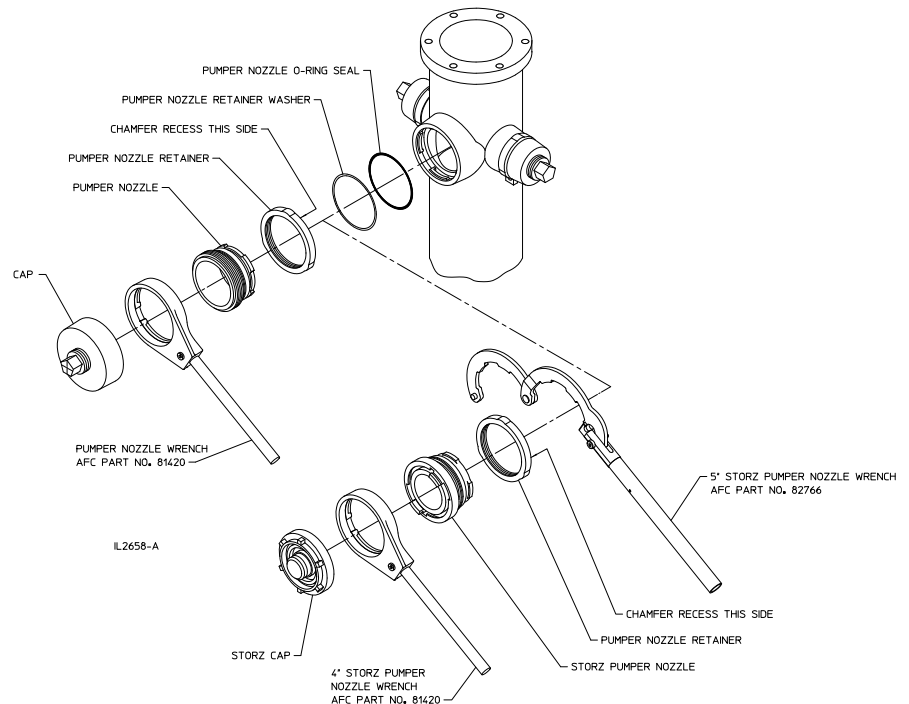



# 4-1/2" AMERICAN-DARLING® MARK 73-5 NOZZLE REPLACEMENT MECHANICALLY ATTACHED 2-1/2" HOSE NOZZLE (FOR HYDRANTS BUILT BEGINNING IN 2006)



**WARNING: POTENTIAL HYDRANT CAP HAZARD. FAILURE TO RELIEVE PRESSURE CAN RESULT IN THE CAP BLOWING OFF, CAUSING SERIOUS INJURY OR DEATH.** Make sure the auxiliary gate valve in the lateral between the main and the hydrant is closed and that the hydrant is not charged with pressure when removing caps.

## Removal

1. Remove cap.
2. Place wrench on the retainer so it engages the rounded protrusions and unthread from nozzle.
3. Rotate nozzle counterclockwise until the two lugs on the nozzle disengage the recesses in the nozzle section socket, which will allow the nozzle to be removed.

## Installation

1. Thread retainer onto the retainer threads of the hose nozzle. **NOTE:** In cases where hose nozzle threads having a larger diameter than the retainer, the retainer will need to be assembled from the lug side only.
2. Place washer over nozzle starting from the end with the two lugs and into the chamfer recess in the retainer.
3. Grease O-ring and place it over nozzle starting from the end with the two lugs and against the washer.
4. Insert the nozzle /retainer/washer/O-ring subassembly into the socket in the nozzle section. Rotate the subassembly clockwise until it stops with the lugs on the nozzle fully engaged in the anti-rotation recesses in the socket.
5. Hand tighten the retainer to press O-ring against the face of the socket.
6. Place the nozzle wrench on the retainer so it engages the rounded protrusions. Tighten the retainer to between 100 – 150 ft-lbs.
7. Clean rust or corrosion from cap threads and replace cap gasket if necessary. Apply a light coat of grease to the nozzle threads and install the cap.

**NOTE: Where grease is specified, use an AMERICAN Flow Control recommended food grade grease.**

### Mechanically Attached Hose Nozzle

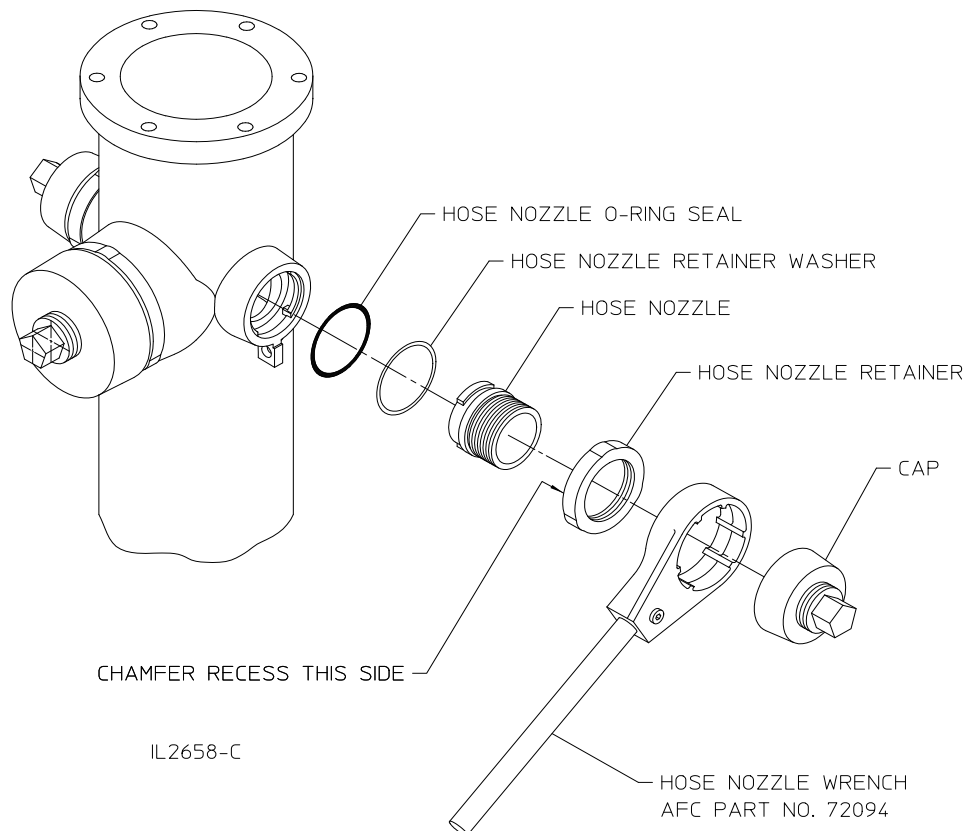

# 4-1/2" AMERICAN-DARLING® MARK 73-5 EXTENSION INSTRUCTIONS



## Procedure

The 4-1/2" AMERICAN-DARLING MARK 73-5 hydrant is extended at the barrel flange above the ground line, eliminating the need for excavation.

## Parts Required for Hydrant Extension

|           |   |                          |
|-----------|---|--------------------------|
| 73-19X-SR | 1 | Extension Barrel*        |
| 73-29-13  | 2 | Unbreakable Flanges      |
| 73-29-14  | 2 | Snap Rings               |
| 73-29-31  | 2 | Rod Coupling Pins        |
| 73-29-40  | 1 | Unbreakable Rod Coupling |
| 73-30-15  | 1 | Extension Rod            |
| 73-38-1   | 2 | Barrel Gaskets           |
| 73-39-9   | 8 | Barrel Bolts and Nuts    |

\*Extension barrels and rods are available in increments of 6 in., starting at 6 in. long.

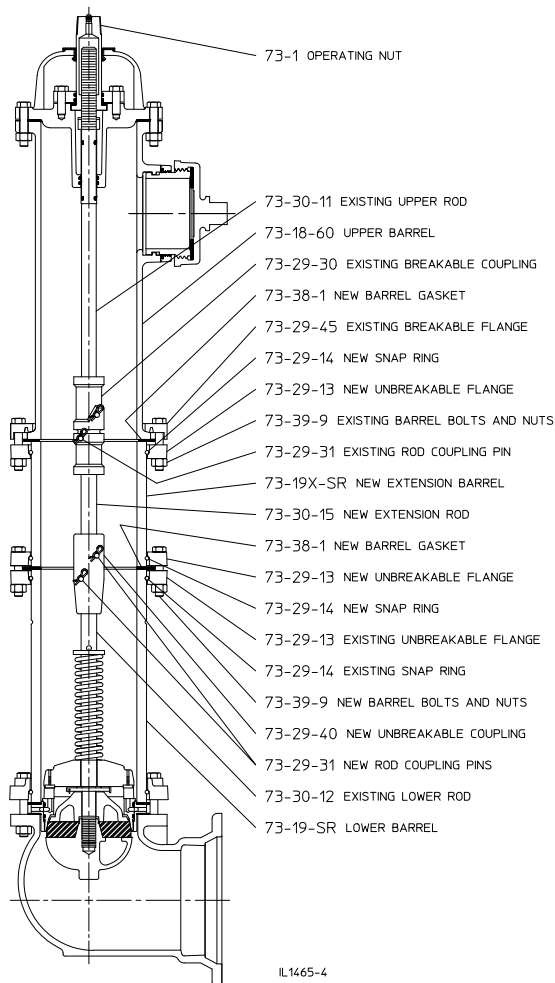

NOTE: The use of extension lengths made by more than one extension kit is not recommended. When combined extension kit and existing trench depth exceeds 9 ft, replace existing lower rod with appropriate length lower rod instead of using rod extension. When combined length exceeds 12 ft rod guides are recommended for lower rod.

1. Close hydrant valve. It is considered safe practice to close the auxiliary valve ahead of the hydrant, or use another means to cut off flow and pressure to the hydrant. Always standing to the side of the hydrant and away from the direction of the hydrant caps, loosen one of the hose caps to relieve any pressure that may be present in the hydrant barrel. **WARNING: FAILURE TO RELIEVE PRESSURE CAN RESULT IN THE CAP BLOWING OFF, CAUSING SERIOUS INJURY OR DEATH.**
2. Remove existing barrel bolts and nuts (73-39-9).
3. Remove existing traffic barrel flange halves (73-29-45).
4. Raise upper barrel (73-18-60) from lower barrel (73-19-SR) by turning operating nut (73-1) in the opening direction and lifting the upper barrel at the same time to prevent the hydrant valve from opening.
5. Raise the upper barrel until there is sufficient separation from the lower barrel to permit removing of the lower rod coupling pin (73-29-31) and clip pin. **Block upper barrel in this position to ensure protection while removing the coupling pins.**
6. Safely remove lower rod coupling pin and clip pin. Lift and remove upper barrel assembly. **Use proper lifting techniques to avoid injury.**
7. Assemble new unbreakable rod coupling (73-29-40) to one end of the new extension rod (73-30-15) in position as shown. Insert a new coupling pin (73-29-31) and clip pin. Assemble other end of new unbreakable rod coupling to existing lower rod (73-30-12) using a new coupling pin (73-29-31) and clip pin.
8. Remove old gasket and place new barrel gasket (73-38-1) on lower barrel.
9. Place assembly on lower barrel making sure gasket and hydrant barrel inside diameters are aligned.
10. Assemble new barrel bolts and nuts (73-39-9). Torque in an alternating pattern to 80 ft-lbs.
11. Place new barrel gasket (73-38-1) on extension barrel. Lift upper assembly and attach existing breakable rod coupling (73-29-30) to new extension rod (73-30-15). **Use proper lifting techniques to avoid injury.**
12. **Block the upper barrel assembly as in Step 5** and insert a new coupling pin (73-29-31) and clip pin in the existing breakable rod coupling (73-29-30).
13. Lower upper barrel assembly to the extension barrel by turning operating nut in the closing direction, making sure gasket remains centered. Lift barrel flange and assemble breakable flange halves by using existing barrel bolts and nuts (73-39-9). Torque in an alternating pattern to 55-60 ft-lbs. Important: **Make sure gap between barrel flange (73-29-45) and new barrel flange (73-29-13) is equal around circumference of flanges.**
14. Safely shell test hydrant for joint tightness.

## 4-1/2" AMERICAN-DARLING® MARK-73-5 SPECIFICATIONS



Fire hydrants shall meet or exceed ANSI/AWWA C502, latest revision. Rated working pressure shall be 250 psig, test pressure shall be 500 psig and hydrants shall include the following specific design criteria:

- The main valve closure shall be of the compression type.
- Traffic feature must be designed for easy 360 rotation of nozzle section during field installation.
- The main valve opening shall not be less than 4-1/2 in. and be designed so that removal of all working parts can be accomplished without excavating.
- The hydrant valve shall be constructed of EPDM rubber and have a vertical taper of 20° or less.
- The bronze seat shall be threaded into an all bronze drain ring.
- The draining system of the hydrant shall be bronze and positively activated by the main operating rod. Hydrant drains shall close completely after no more than three turns of the operating nut. There shall be a minimum of two internal ports and four outlets to the exterior of the hydrant. Drain shutoff to be direct compression closure. Sliding drains are not permitted.

Hydrant barrels shall be made of ductile iron. Nozzles shall be retained by collars. Threaded-in nozzles and nozzles using set screws, are not allowed.

- Hydrant upper barrel shall be factory coated with Electrodeposition (E-coat) epoxy primer and catalyzed two part polyurethane top coating. Base shall be coated with fusion bonded epoxy. All bolting below grade shall be 304 stainless steel.
- Friction loss not to exceed 3.5 psig at 1000 gpm through 4-1/2 in. pumper nozzle.
- Hydrants shall be equal to the **4-1/2" American-Darling MARK-73-5** by AMERICAN Flow Control fire hydrant.



# AMERICAN

## FLOW CONTROL

**THE RIGHT WAY**

### AMERICAN Flow Control

P.O. Box 2727  
Birmingham, AL 35202-2727  
Phone: 800-326-8051  
Fax: 800-610-3569  
Email: [afcsales@american-usa.com](mailto:afcsales@american-usa.com)

### Waterous Company

125 Hardman Avenue South  
South St. Paul, MN 55075-2421  
Phone: 888-266-3686  
Fax: 800-601-2809  
Email: [afcsales@american-usa.com](mailto:afcsales@american-usa.com)

**[WWW.AMERICAN-USA.COM](http://WWW.AMERICAN-USA.COM)**



Product literature may become outdated. AMERICAN is not responsible for out-of-date information, errors or omissions.  
Product diagrams are illustrative only. Please contact AMERICAN for the most current product information.