

L



JAY R. SMITH MFG. CO.®
 DIVISION OF SMITH INDUSTRIES, INC.
 POST OFFICE BOX 3237
 MONTGOMERY, ALABAMA 36109-0237 (USA)
 TEL: 334-277-8520 FAX: 334-272-7396 www.jrsmith.com



MEMBER OF:

LOCATION

DRAWING NUMBER
S4111SIZE
ASCALE:
NONEDATE:
2-16-70APPROVED BY:
JMCHECKED BY:
BHDRAWN BY:
RK

4111 SERIES

DIMENSIONS ARE SUBJECT TO MANUFACTURERS TOLERANCE AND CHANGE WITHOUT NOTICE

FINISHED FLOOR CLEANOUTS WITH "TWIS-TO-FLOOR®" ADJUSTABLE TOPS

ROUND EXTRA HEAVY DUTY NICKEL BRONZE TOP

FUNCTION: Used in hospitals, schools, institutional and industrial buildings where floors are subject to heavy load traffic.

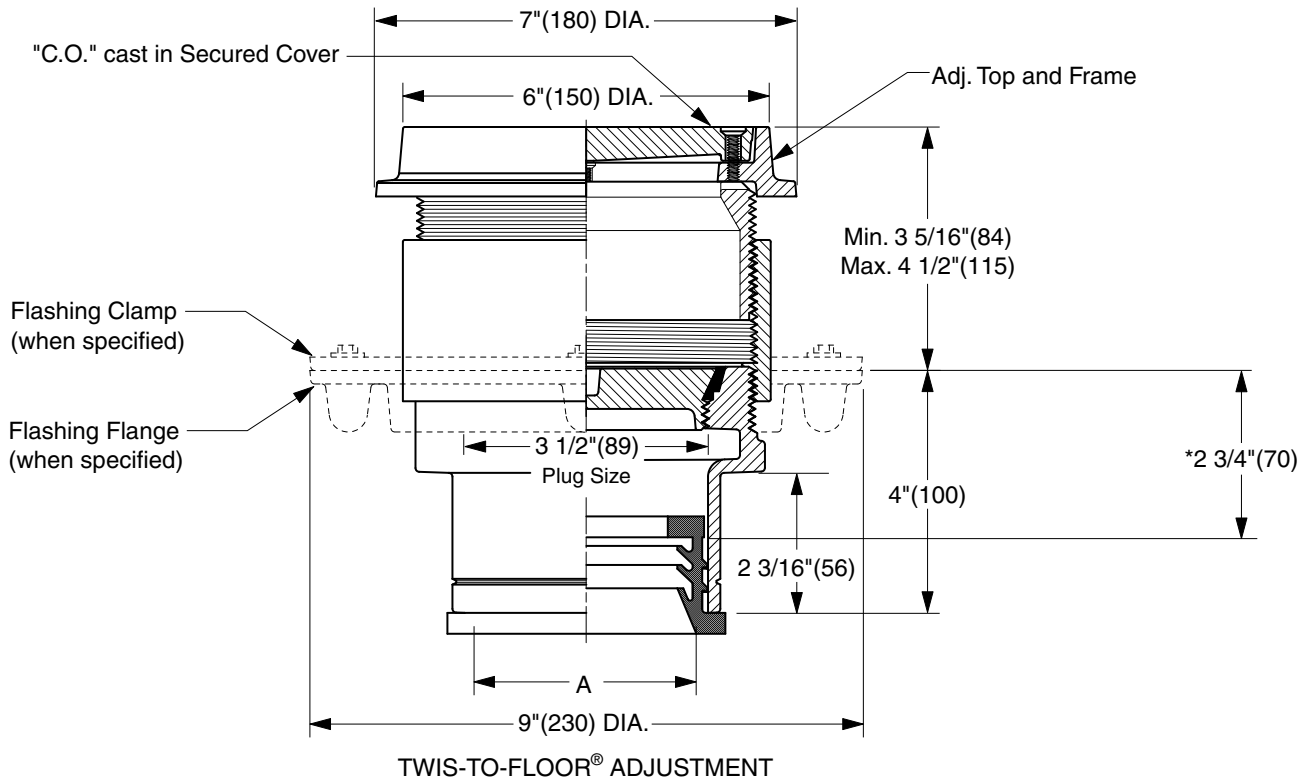

"A" (Pipe Size) = 02(50), 03(75) or 04(100)

* This Dimension to Internal Stop of Speedi-set Gasket.

- Fig. 4111L.....Gasket Seal - ABS Plug
- Fig. 4112L.....Gasket Seal - Bronze Plug
- Fig. 4113L.....Taper Thread - Bronze Plug
- Fig. 4114L.....Taper Thread - ABS Plug

(Twis-to-Floor® design shown with gasketed plug.)

NOTE: Dimensions shown in parentheses are in millimeters.

REGULARLY FURNISHED:

Duco Cast Iron Cleanout with Round Adjustable Scoriated Secured Nickel Bronze Top. Closure Plug Type as Indicated By Figure Number Selected.

VARIATIONS:

- Flashing Flange -F
- Flange with Flashing Clamp -F-C
- Vandal Proof Top -U

OPTIONAL MATERIALS:

- Galvanized Cast Iron -G
- Polished Bronze Top -PB

▲ Available in Extra Heavy, Service Weight or NO-HUB.

REV.	DATE	DESCRIPTION	BY	CKD. BY	WEIGHT POUNDS	VOLUME CUBIC FEET	FIGURE NUMBER
L	12/17/04	Added Width Dimension at Top	JJ	CL			4111 SERIES
K	07/29/02	Corrected Clamp & Flange view	JJ	CL			
J	04/12/01	Added dimension and note	JJ	CL			
H	10/27/00	New design	JJ	BS			

FINISHED FLOOR CLEANOUTS WITH "TWIS-TO-FLOOR®" ADJUSTABLE TOPS

ROUND EXTRA HEAVY DUTY NICKEL BRONZE TOP

FUNCTION: Used in hospitals, schools, institutional and industrial buildings where floors are subject to heavy load traffic.

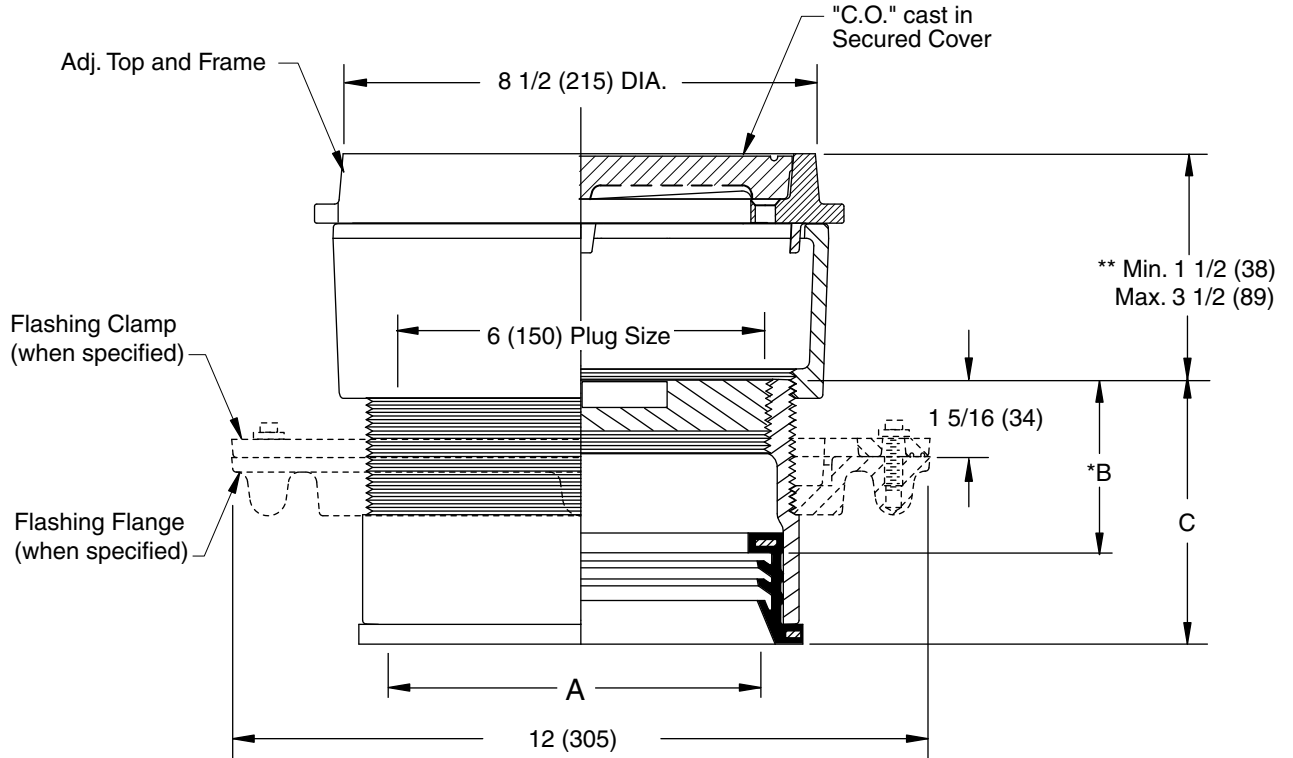

SPEEDI-SET OUTLET ▲

"A" (Pipe Size) = 06(150) & 08(200)

A SIZE	B	C
06(150)	*3(76)	4 9/16(117)
08(200)	*3 1/4(83)	4 13/16(121)

▲ Available in "L" Service Weight, "LXH" Extra Heavy or "LPVC" PVC or ABS. "LPVC" applicable to 06(150) Pipe Size only.
 * This Dimension to Internal Stop of Speedi-Set Gasket.
 ** When Flange-F is specified Min. 1 1/2 (38) becomes 2 (51)

"TWIS-TO-FLOOR®" ADJUSTMENT

SPEEDI-SET OUTLET ▲

Fig. 4113L.....Taper Thread - Bronze Plug

REGULARLY FURNISHED:

Duco Cast Iron Cleanout with Taper Thread Bronze Plug and Round Adjustable Scoriated Secured Nickel Bronze Top.

VARIATIONS:

- Flashing Flange -F
- Flange with Flashing Clamp -F-C
- Vandal Proof Top -U

OPTIONAL MATERIALS:

- Galvanized Cast Iron -G
- Polished Bronze Top -PB

NOTE: Dimensions shown in parentheses are in millimeters.

DRAWING NUMBER
S411BS

SIZE
A

SCALE:
NONE

DATE:
5-5-06

APPROVED BY:
CEL

CHECKED BY:
CL

DRAWN BY:
RN

FIGURE NUMBER
4113

WE CAN ASSUME NO RESPONSIBILITY FOR USE OF SUPERSEDED OR VOID DATA

REV.	DATE	DESCRIPTION	BY	CKD. BY

WEIGHT POUNDS	VOLUME CUBIC FEET

FIGURE NUMBER 4113
