



Installation Instructions

Evaporator Coil

TABLE OF CONTENTS	PAGE
General	1
Vertical	2
Horizontal	2
Multi-Position	3-5
Condensate Drain	5
Metering Device	6
Refrigerant Line Installation	7
Refrigerant Line Installation	7
Coil Cleaning.....	7
Warranty	8
Installation Check List.....	8



GENERAL

ADP evaporator coils are designed for use with AC condensing units or heat pump units. These instructions are intended as a general guide and do not supersede local codes in any way. Consult with local authorities having jurisdiction before installation. **Read this installation manual and all safety messages prior to installing the evaporator coil.**

Check coil for shipping damage and verify the contents of the box containing the evaporator coil. If you should find damage, immediately contact the last carrier. Verify the efficiency performance requirements, such as SEER, EER, and/or HSPF, are appropriate with the matched condensing or heat pump units. Check outdoor unit manufacturer for proper line sizing. **Coils are shipped with a 10 psi dry air holding charge. Puncture rubber plug on suction line to release charge before removing plugs.** The absence of pressure does not verify a leak. Check the coil for leaks before installing or returning it to your wholesaler.

Position the coil on the outlet of the furnace using sheet metal screws. In horizontal installations, the coil should be pitched approximately 1/2" toward the drain connections. **NOTE:** Sloping over 5/8" may cause blow off into the auxiliary drain hole in high static situations. Drain pans are made of a polymer that can withstand temperatures up to 450°F. **Maintain a 3" clearance on oil or drum type heat exchangers and 1 1/2" on sectionalized heat exchangers. Airflow face velocity above 350 ft/min is not recommended for downflow or counterflow applications due to potential water blow-off.** Refer to Specification Guide for limitations.

SAFETY CONSIDERATIONS

Your safety and the safety of others are very important.

We have provided many important safety messages in this manual and on your appliance. Always read and obey all safety messages.



This is the safety alert symbol.

This symbol alerts you to potential hazards that can kill or hurt you and others.

All safety messages will follow the safety alert symbol and signal word. These signals words mean the following:

DANGER: You can be killed or seriously injured if you don't immediately follow instructions.

WARNING: Indicate a potentially hazardous situation which, if not avoided, could result in death or serious injury.

CAUTION: Indicates a potentially hazardous situation which, if not avoided, may result in minor or moderate injury. Caution may also be used to alert against unsafe practices.

NOTICE: Indicates a statement of company policy as the message relates directly or indirectly to the safety of personnel or protection of property.

IMPORTANT: More detailed information concerning the statement of company policy as the message relates directly or indirectly to the safety of personnel or protection of property.

All safety messages will tell you what the potential hazard is, tell you how to reduce the chance of injury, and tell you what can happen if the instructions are not followed.



** Note: Large tonnage coils (greater than 5 tons) are not AHRI certified and do not have Microban® protection.



Product improvement is a continuous process at Advanced Distributor Products. Therefore, product specifications are subject to change without notice and without obligation on our part. Please contact your ADP representative or distributor to verify details.

© by Advanced Distributor Products. All rights reserved.

VERTICAL

Vertical A-Coils are designed for upflow and downflow applications. Vertical drain pans have drain connections on the right and left front side of the evaporator coil. **Airflow face velocity above 350 ft/min is not recommended for downflow applications due to potential water blow-off.**

Refer to Specification Guide for limitations. In downflow applications, aluminum foil tape must be applied to seal the top edge of the insulation to the cabinet. This tape will prevent the possibility of the insulation delaminating and blocking airflow.

DEDICATED HORIZONTAL

Dedicated horizontal A-Coils and Slab Coils are designed for horizontal applications only. Horizontal A-Coils 17.5" and taller include furnace plate adaptors to facilitate proper fit with furnaces of different widths. **Splash guard installation is not required on horizontal coils.**

- Proper performance for **Horizontal A-Coils with top connections** requires that the air flows out through the side of coil where the top connections are located (Figure 1).

- **Horizontal A-Coils with side connections** are bidirectional (Figure 2). Shown below with panels cut-away for clarity.
- **Slab Coils** are bidirectional and require a transition duct to complete installation (Figure 3).
- For **horizontal A-Coils with side connections**, the suction line section inside the cabinet should be insulated with Armaflex® insulation (Figure 4).

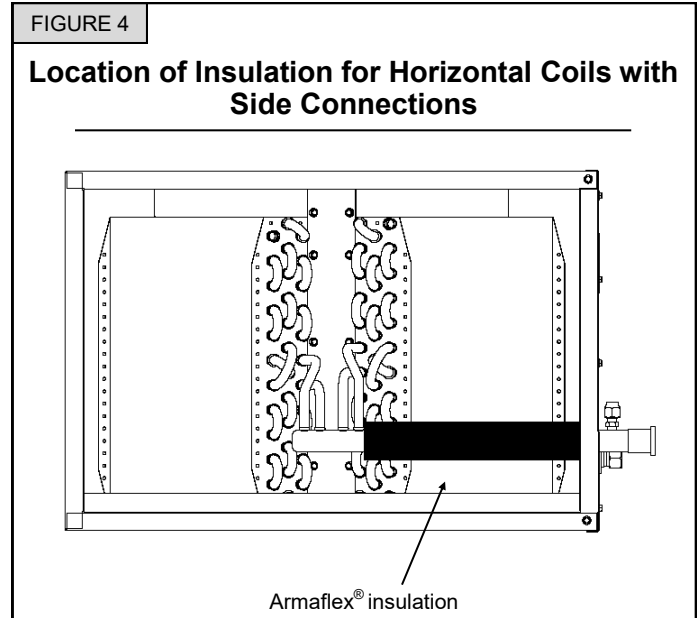
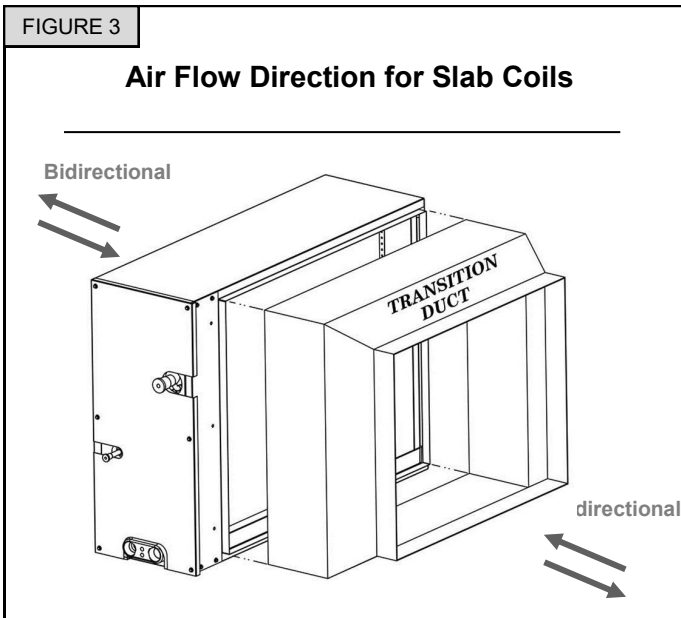
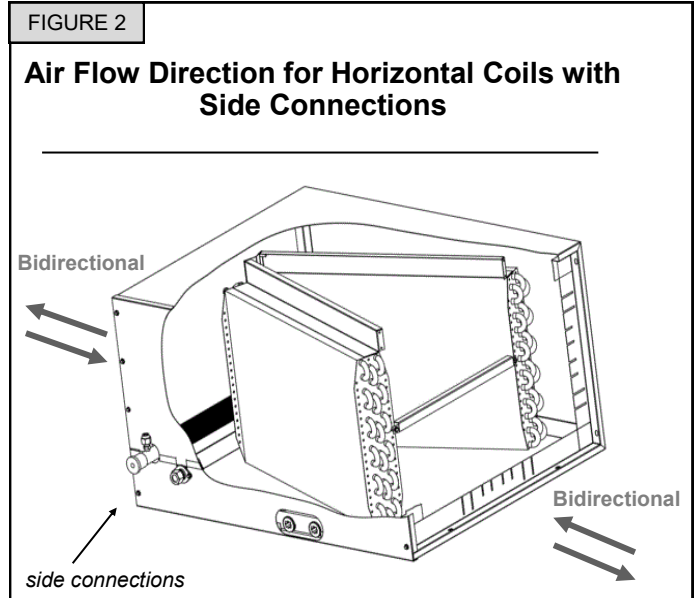
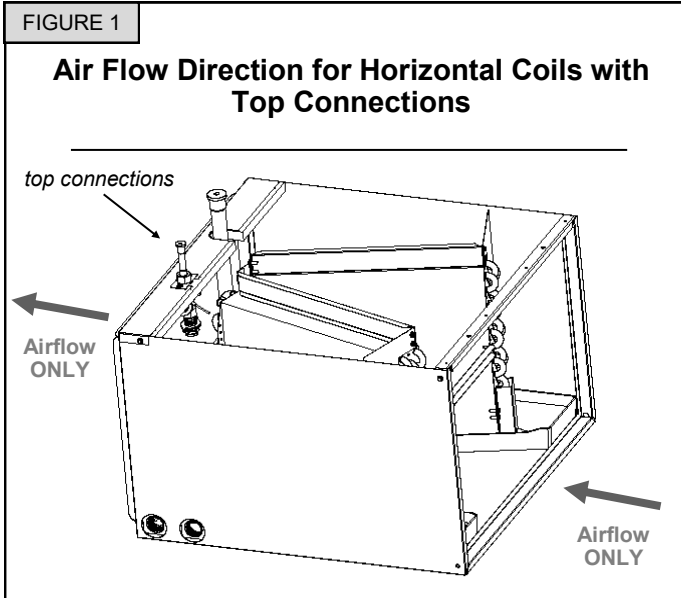

MULTI-POSITION

Multi-Position A-Coils come factory installed with a vertical and horizontal drain pans and can be configured for upflow, downflow, horizontal blow-through or horizontal pull-through installations. In the center opening of vertical drain pan, a metal Inlet Air Restrictor is factory installed and is required for horizontal applications. It may be removed for vertical applications. **Airflow face velocity above 350 ft/min is not recommended for downflow or counterflow applications due to potential water blow-off.** Refer to Specification Guide for limitations.

For horizontal configurations, install splash guard (included) onto the coil outlet, and extend suction line insulation into the coil cabinet by 2" to prevent moisture from dripping onto the insulation (the rubber grommet may need to be moved). Splash guard installation is not required for vertical configurations. Bottom flange of guard should rest on pan and sides screwed to the duct flanges. See page 4, Figures 6 and 7 for splash guard instructions.

In downflow and counter flow configurations, aluminum foil tape must be applied to seal the top edge of the insulation to the cabinet. This tape will prevent the possibility of the insulation delaminating and blocking airflow. In horizontal pull-through and counter flow configurations, a minimum 12" transition is required in front of the coil as shown in Figure 5. This is required to ensure proper airflow distribution and to reduce pressure drop.

Coils that are 20" or less in height and are installed in a cabinet with a height of 25-1/2" or greater do not require a transition; all other coil models require this transition. Coil should be level, or pitched slightly toward the drain connection. It is recommended to add silicone caulk between drain pans to prevent water carryover. **Note: Multi-Position A-Coils are also field convertible from left-to-right or right-to-left; see page 5 for instructions on field conversion for horizontal airflow.**

Additional pre-startup checklist for Multi-Position A-Coils:

- Install splash guard (Figure 5 configurations A and B)
- Install 12" transition as shown (non-standard horizontal applications / Figure 5 configurations B and C)
- Factory installed Inlet Air Restrictor should be present in the center opening of the drain pan (horizontal applications)
- Factory installed internal water diverter should be in place (Figure 8, item 5)
- Extend suction line insulation into cabinet (counter flow)
- Tape top edge of insulation (counter flow)

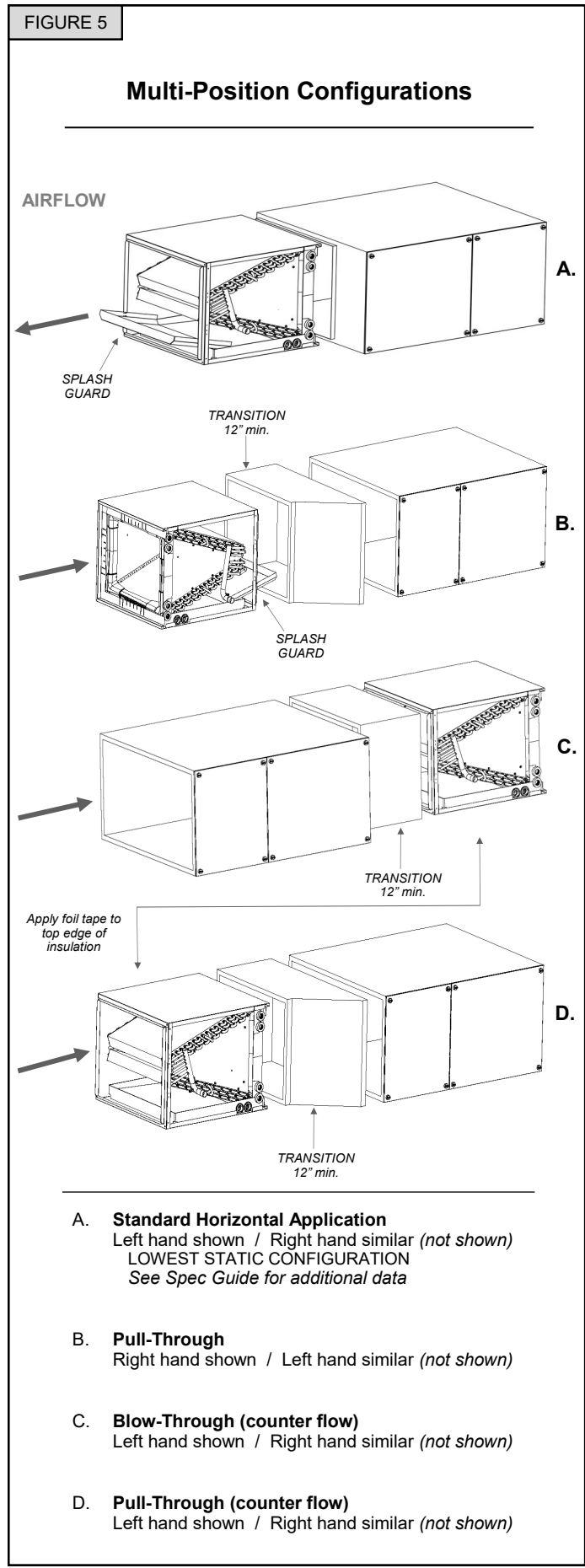

MULTI-POSITION (splash guard)

FIGURE 6

Splashguard without Front Slope

Seal splashguard seams with silicone or other sealant.

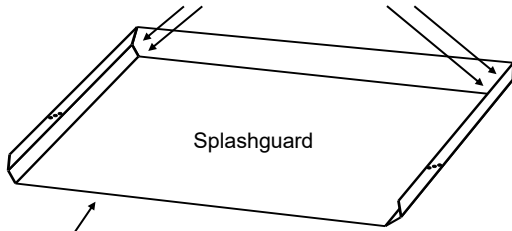

Open end of splashguard should rest on the horizontal drain pan.

Fasten splash guard to duct flanges with (4) sheet metal screws. (2) on each side. Screws can be installed from the inside or outside.

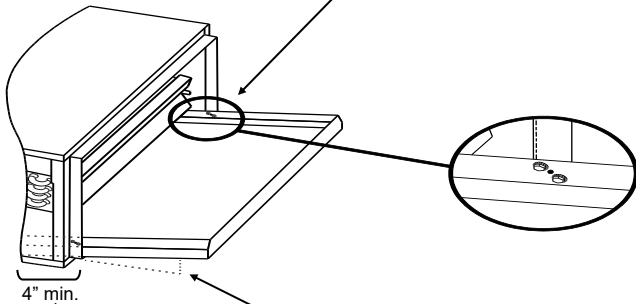

4" min.

Angle splashguard to ensure proper water drainage back into horizontal drain pan.

Splashguard should overlap the horizontal drain pan by at least 4".

FIGURE 7

Splashguard with Front Slope

Holes used to mount splashguard to duct flanges.

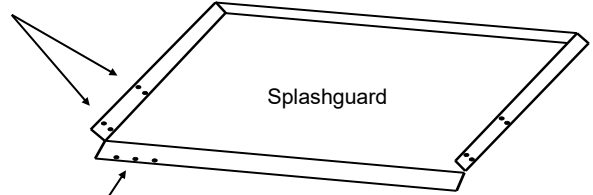

Caution: These holes are for manufacturing purposes only. **DO NOT** use for installation!

First set of mounting holes are used when horizontal drain pan is flush with housing.

Second set of mounting holes are used when horizontal drain pan is shorter than cabinet height.

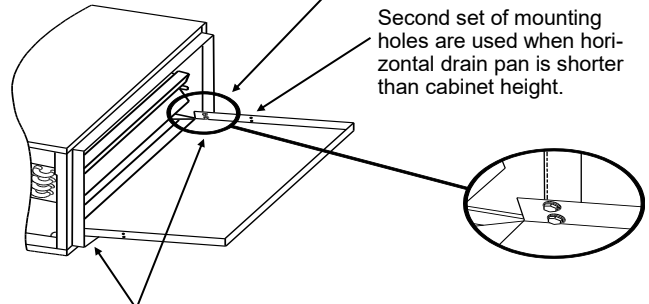

Fasten splash guard to duct flanges with (4) sheet metal screws. (2) on each side. Screws can be installed from the inside or outside.

FIGURE 8

Multi-Position Field Conversion

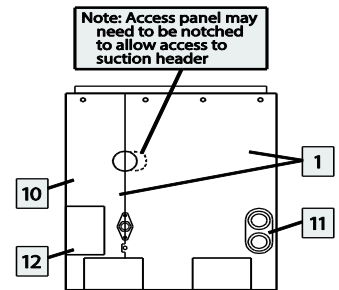
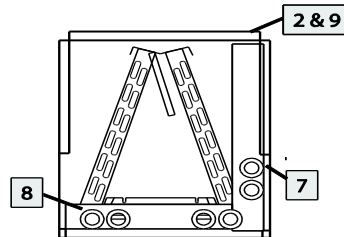
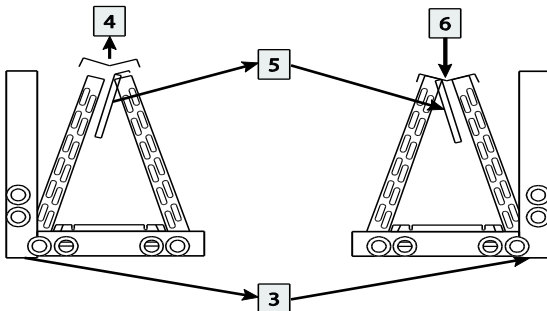

MULTI-POSITION (field conversion)

Field Conversion Instructions from Left-to-Right or Right-to-Left Airflow

Note: This applies only to models available in multi-position; see Specification Guide for details; typical horizontal left-to-right conversion is shown.

FOR EACH STEP, REFER TO FIGURE 8:

1. Remove front panels.
2. Remove the top tie bar and pull the coil assembly from the housing.
3. Remove the horizontal drain pan, and re-install it to the opposite side of the coil (**Note:** horizontal drain pan must have drain plugs tightly closed in the rear of the unit).
4. Remove the top plate.
5. Remove the water diverter, and re-install it to the opposite slab (**Note:** If water diverter is attached by screws, remove screws, and bend tab straight or cut tab off).
6. Replace the top plate, and apply sealant to seal any air gaps.
7. Before re-inserting the coil assembly, cut the front flange on the housing and fold it back to allow access to the horizontal drain connections (**Note:** Copy the factory cut-out on the opposite side of the housing).
8. Slide the coil assembly back into the housing (**Note:** If unit is equipped with a sheet metal spacer, it must be moved to the opposite side of the housing).
9. Re-install the top tie bar.
10. Re-install the piping panel to the housing.
11. Cut a hole in the access panel to allow access to the horizontal drain connections, and re-install the access panel to the housing (**Note:** Access panel may need to be notched to allow access to suction header).
12. Seal unused condensate drain connection cutout holes in the front panel to prevent air leakage.

CONDENSATE DRAIN

Coils are equipped with multiple drain connections. Determine the drain connections to be used and note the difference between the primary (green) and secondary (red) openings. Drain plugs are provided for all openings; remove and discard the appropriate plugs with $\frac{1}{2}$ " drive ratchet and verify that remaining plugs are tight (2.5 ft-lbs). Attach drain line to pan with $\frac{3}{4}$ " male pipe thread PVC fittings. Hand tight is adequate – **do not over tighten & do not reduce drain line size!**

Route drain(s) line so they will not be exposed to freezing temperatures and do not interfere with accessibility to the coil, air handling system or filter. The drain should be pitched downward 1" per 10' with a 2" trap as close to the coil as possible. If line makes a second trap, or has an extended run before termination, a vent tee should be installed after the trap closest to the pan. See Figure 9.

If the coil is located in or above a living space where damage may result from condensate overflow, a separate $\frac{3}{4}$ " drain must be provided from the secondary drain connection. Run this drain to a place in compliance with local installation codes where it will be noticed when unit is operational. Condensate flowing from the secondary drain indicates a plugged primary drain. Prime the trap with water. Test line for leaks. Test water flow with unit in operation. An auxiliary drain pan should be installed under the unit, and have a larger footprint than the coil, as specified by most local building codes.

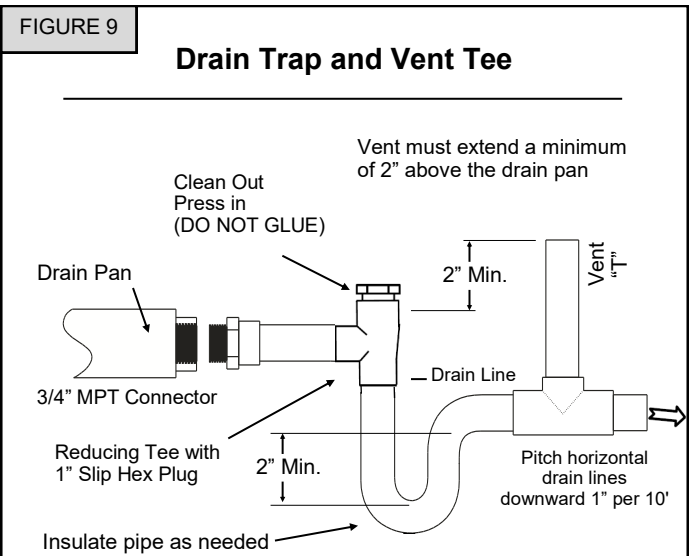



IMPORTANT

The Clean Air Act of 1990 bans the intentional venting of refrigerant (CFC's and HFC's). Approved methods of reclaiming must be followed. Fines and/or incarceration may be levied for non-compliance.

METERING DEVICE

Coils are suited for R-22 and R-410A refrigerants and can be used with a piston or a TXV. See kit instructions for change out or installation. ADP recommends placing a wet rag around the suction line at the cabinet during brazing to prevent overheating and damaging the sensing bulb.

For optimum performance, reattach and insulate the bulb at a 10 to 2 o'clock position outside of the cabinet to the main suction line no more than one foot from the suction line connection. If necessary, the bulb can be installed on a vertical suction line. In this instance, the bulb must be placed before any trap, with the bulb's capillary tube facing upward. When changing a system from AC to heat pump or heat pump to AC, check the current TXV specifications to determine if a TXV replacement is required. **If the evaporator coil contains a non-bleed TXV and is used with a condensing unit containing a reciprocating compressor, a hard start kit will be required on the condensing unit.**

 **IMPORTANT** 

When changing the metering device, ensure the metering device matches the refrigerant type and capacity of the condensing unit. Failure to do so will result in poor performance and possible compressor damage. All coils must be matched properly as listed in the AHRI directory.

Cased coils with a piston metering device are shipped with a cap and hex nut over the threaded fitting. Remove the cap and nut slowly, allowing charge to escape, and secure the liquid line stub (attached to cabinet) to the distributor assembly with hex nut. Discard cap.

For optimum performance, the piston should be sized to match the recommendation from the outdoor unit manufacturer. If the outdoor unit manufacturer does not recommend a piston size, refer to the piston size chart. When changing pistons, refer to Figure 10 and use the following procedure:

1. Loosen hex nut located on liquid line and separate from distributor assembly.
2. Remove the existing piston from inside the distributor assembly.
3. Insert the desired piston into the distributor assembly.
4. Inspect Teflon O-Ring and replace if damaged. Ensure Teflon O-Ring is in place.
5. Re-install hex nut to body and torque to 10 ft-lbs.

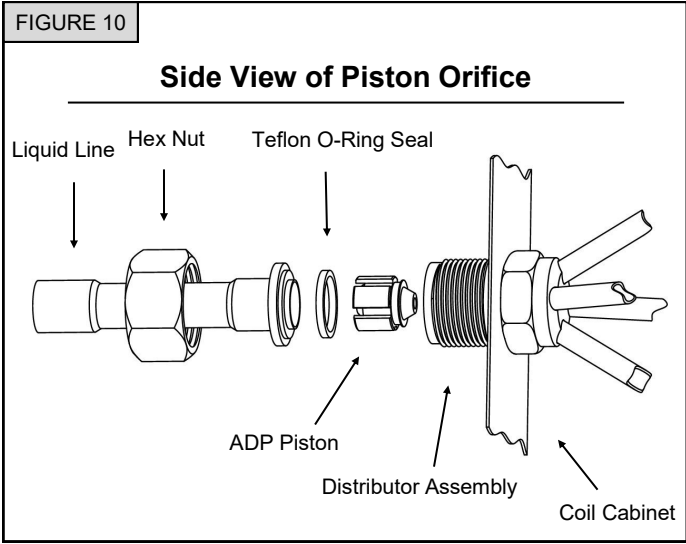

COIL CLEANING

The coils should be inspected and preferably cleaned a minimum of once a year or more often, if necessary. Cleaning of the indoor unit's coil should be performed by a licensed professional service technician (or equivalent).

1. 1. Put on personal protective equipment – Safety glasses and/or face shield, waterproof clothing and gloves.
2. 2. Vacuum or brush the coil to remove any matted or surface foreign debris from the fins (dirt, animal hair, etc).
3. 3. Only clean potable water should be used to clean the coils. Clean coil slab surfaces by spraying steady and uniformly at a vertical angle of 30 to 45 degrees with a constant stream of water at moderate pressure (**less than 50 psig**) from top to bottom. A fan nozzle will work best. Do not spray the coil from a horizontal direction.

4. 4. Use of acidic (below 5) or alkaline (above 9) cleaners can strip off factory protective coatings and reduce the life of an aluminum coil.
5. 5. Alkaline (also called no-acid) coil cleaners are products that has a pH greater than 7. Acid coil cleaners are products that have a pH less than 7.

Note: Attempting to back flush from the inside of the coil will require removing parts from the unit, and it may be very difficult to flush the whole coil surface. Attempting to blow water through a coil will slow the water stream and reduce the *lushing action of the outer fin surface*.

REFRIGERANT LINE INSTALLATION

ADP recommends installing a filter drier and sight glass in the liquid line. While brazing, purge the system with Nitrogen to prevent contamination. ADP recommends reattaching and insulating the TXV sensing bulb at a 10 to 2 o'clock position on the suction line, outside the coil housing, no more than one foot from the connection. Evacuate the system to 500 microns

to ensure proper air and moisture removal (**Note:** *Deep evacuation or triple evacuation method recommended*). Open the suction service valve slowly and allow the refrigerant to bleed into the system before opening the liquid service valve.

REFRIGERANT CHARGING INSTRUCTIONS ¹

When charging in cooling mode, the outdoor temperature should be 60°F or higher. To allow the pressures to stabilize, operate the system a minimum of 15 minutes between adjustments. When adjusting charge to systems with micro-channel outdoor coils, make small (1 ounce or less) adjustments as these systems are very sensitive to refrigerant charge.

TXV Charging^{2, 3, 4} – Use the charging method recommended by the outdoor unit instructions. Alternatively, ADP recommends charging to 12°F sub-cooling for AC units and 10°F sub-cooling for heat pump units. In addition, if equipped with an adjustable valve, adjust to 10°F superheat.

Fixed Orifice Charging^{2, 3, 4} – Use the superheat recommended by the outdoor unit instructions. Alternatively, ADP recommends charging to the superheat table below.

Outdoor Air Temp. (°F)	60	65	70	75	80	85	90	95	100	105	110	115
Superheat (°F)	31	28	25	22	20	16	13	10	8	6	5	5

For heat pump units initially charged in the cooling mode, final adjustments to charge in the heating mode are acceptable if necessary. Some heat pump units require charging in the heating mode. In this case, refer to the outdoor instructions for recommended charging procedures.

If the system is undercharged after the initial charge, add refrigerant until the sight glass is clear and recommended pressures, temperatures, sub-cooling and superheat can be obtained. If the system is overcharged after the initial charge, recover refrigerant until recommended pressures, temperatures, sub-cooling and superheat can be obtained.

Notes:

1. If any problems or questions regarding charge occur, contact customer service.
2. OEM charging methods vary depending on design and application. Verify all recommended pressures, temperatures, sub-cooling and superheat settings result in the proper charge.
3. ADP coils may require charge compensation due to size variation versus the OEM coil.
4. Temperatures are $\pm 2^\circ\text{F}$ unless otherwise recommended.

ADP LIMITED WARRANTY

Term of Warranty

Advanced Distributor Products (ADP) warrants that products sold shall be of merchantable quality, free of defects in material and workmanship, under normal use and service, for a period of five (5) years from the date of installation, **not** to exceed six (6) years from the date of manufacture subject to the terms of ADP's limited warranty.

For information on this product's warranty, including accessing complete warranty terms, registering for an extended warranty* or instructions on filing a warranty claim, please go to www.ADPwarranty.com.

* *In such states or provinces where registration requirements are prohibited, failure to complete registration by the consumer does not diminish his or her warranty rights.*

Equipment Information

Please complete information below and retain this warranty for records and future reference.

Unit Model Number: _____

Serial Number: _____

Installing Contractor: _____

Installation Date: _____

Phone: _____



INSTALLATION CHECKLIST

Downflow:

- <350 ft/min
- Tape top edge of insulation

Multi-Position:

- Complete additional checklist on page 3

Horizontal:

- Slope the coil approximately 1/2" toward the drain connections.

Metering Device:

- Verify and/or install correct TXV or piston

TXV Installation Only:

- Place TXV bulb at 10 to 2 o'clock position
- Insulate bulb
- Connect equalizer line

Drains:

- Install and trap primary and secondary condensate drains
- If over a finished space, install secondary drain pan

Air Path:

- Cover any unused knockouts

Charging:

- Charge per charging instructions

