

Bosch BOVB 18 Split System Heat Pump

Condensing Units Up to 18.5 SEER

2-3-4-5 Ton Capacity

R410A



BOSCH

Installation Instructions



Table of Contents

1 Key to Symbols and Safety Instructions	4	12 Electrical - High Voltage	20
1.1 Key to Symbols	4	12.1 High Voltage Power Supply	20
1.2 Safety	4	12.2 High Voltage Disconnect Switch	20
2 Unit Location Considerations	6	12.3 High Voltage Ground	20
2.1 Unit Dimensions	6	13 Start Up	21
2.2 Refrigerant Piping Limits	6	13.1 System Start Up	21
2.3 Location Restrictions	7	14 System Charge Adjustment	22
3 Unit Preparation	8	14.1 Charging: Weigh-In Method	22
3.1 Prepare the Unit for Installation	8	14.2 Subcooling Charging And Refrigerant Adjustment In Cooling (Above 55°F Outdoor Temp.)	22
4 Setting the Unit	8	15 System Operation and Troubleshooting	25
4.1 Pad Installation	8	15.1 Control Logic Description	25
5 Refrigerant Line Considerations	9	15.2 Sensors (Thermistors/Pressure Transducer)	25
5.1 Refrigerant Line and Service Valve Connection Sizes	9	15.3 Pressure Equalizer Valve (PEV)	25
5.2 Required Refrigerant Line Length	9	15.4 Defrost Description	25
5.3 Refrigerant Line Insulation	9	15.5 Compressor Crankcase Heater Description	26
5.4 Reuse Existing Refrigerant Lines	9	15.6 Reversing Valve Operation	26
6 Refrigerant Line Routing	10	15.7 Protection Functions	26
6.1 Precautions	10	15.8 Fault Code Table	27
7 Refrigerant Line Brazing	11	15.9 Parameter Point Check Table	28
7.1 Braze The Refrigerant Lines	11	15.10 Control Board Overviews	29
8 Refrigerant Line Leak Check	13	15.11 Error Code Troubleshooting	31
8.1 Check For Leaks	13	15.12 Temperature and Resistance Relationship Tables (for Sensors)	37
9 Evacuation	13	15.13 Temperature and Resistance Relationship Tables (for T5)	38
9.1 Evacuate the Refrigerant Lines and Indoor Coil	13	16 Wiring Diagrams	40
10 Service Valves	14	16.1 BOVB36-18 (3 ton)	40
10.1 Open the Service Valves	14	16.2 BOVB60-18 (5 ton)	41
11 Electrical - Low Voltage	15	17 Care and Maintenance	42
11.1 Low Voltage Maximum Wire Length	15	17.1 Cleaning Precautions	42
11.2 Low Voltage Hook-Up Diagrams	15	17.2 Maintenance – Pre-Season Inspection	42
11.3 Thermostat Wiring Diagrams	15		

1 Key to Symbols and Safety Instructions

1.1 Key to Symbols

Warnings



Warnings in this document are identified by a warning triangle printed against a grey background. Keywords at the start of a warning indicate the type and seriousness of the ensuing risk if measures to prevent the risk are not taken.

The following keywords are defined and can be used in this document:

- ▶ **DANGER** indicates a hazardous situation which, if not avoided, will result in death or serious injury.
- ▶ **WARNING** indicates a hazardous situation which, if not avoided, could result in death or serious injury.
- ▶ **CAUTION** indicates a hazardous situation which, if not avoided, could result in minor to moderate injury.
- ▶ **NOTICE** is used to address practices not related to personal injury.

Important information



This symbol indicates important information where there is no risk to people or property.

1.2 Safety

Please read before proceeding



WARNING: ELECTRICAL HAZARD 380 VOLTS DC

- ▶ Failure to follow this warning could result in property damage, severe personal injury, or death.
- ▶ WAIT THREE (3) MINUTES after disconnecting power prior to touching electrical components as they may hold a dangerous charge of 380 VDC, then verify DC Voltage is less than 42VDC at inverter TEST POINTS P-N (refer to wiring diagram for test location).

NOTICE:

- ▶ This document is customer property and is to remain with this unit. Please return to service information pack upon completion of work.
- ▶ These instructions do not cover all variations in systems or provide for every possible contingency to be met in connection with the installation.
- ▶ Should further information be desired or should particular problems arise which are not covered sufficiently for the purchaser's purposes, the matter should be referred to your installing dealer or local distributor.



The manufacturer recommends installing only approved matched indoor and outdoor systems. All of the manufacturer's split systems are AHRI rated only with TXV indoor systems. Some of the benefits of installing approved matched indoor and outdoor split systems are maximum efficiency, optimum performance and the best overall system reliability.



This document contains a wiring diagram and service information. This is customer property and is to remain with this unit. Please return to service information pack upon completion of work.



WARNING:

- ▶ This information is intended for use by individuals possessing adequate backgrounds of electrical and mechanical experience. Any attempt to repair a central air conditioning product may result in personal injury and/or property damage.

**WARNING: HAZARDOUS VOLTAGE**

- ▶ Failure to follow this warning could result in property damage, severe personal injury, or death.
- ▶ Disconnect all electric power, including remote disconnects before servicing. Follow proper lockout/tagout procedures to ensure the power cannot be inadvertently energized.

**CAUTION: GROUNDING REQUIRED**

- ▶ Failure to inspect or use proper service tools may result in equipment damage or personal injury. Reconnect all grounding devices. All parts of this product that are capable of conducting electrical current are grounded. If grounding wires, screws, straps, clips, nuts, or washers used to complete a path to ground are removed for service, they must be returned to their original position and properly fastened.

**WARNING: REFRIGERANT OIL**

- ▶ Any attempt to repair a central air conditioning product may result in property damage, severe personal injury, or death.
- ▶ These units use R-410A refrigerant which operates at 50 to 70% higher pressures than R-22. Use only R-410A approved service equipment. Refrigerant cylinders are painted a "Rose" color to indicate the type of refrigerant and may contain a "dip" tube to allow for charging of liquid refrigerant into the system. All R-410A systems with variable speed compressors use a PVE oil (FV50S or equivalent) that readily absorbs moisture from the atmosphere to limit this "hygroscopic" action. The system should remain sealed whenever possible. If a system has been open to the atmosphere for more than 4 hours, the compressor oil must be replaced. Never break a vacuum with air and always change the driers when opening the system for component replacement.

**WARNING: SERVICE VALVES**

- ▶ Failure to follow this warning will result in abrupt release of system charge and may result in personal injury and/or property damage. Extreme caution must be exercised when opening the Liquid Line Service valve. Turn valve stem counterclockwise only until the stem contacts the rolled edge.

**WARNING: BRAZING REQUIRED**

- ▶ Failure to inspect lines or use proper service tools may result in equipment damage or personal injury. If using existing refrigerant lines make certain that all joints are brazed, not soldered.

**WARNING: HOT SURFACE**

- ▶ May cause minor to severe burning. Failure to follow this Caution could result in property damage or personal injury. Do not touch top of compressor.

**WARNING: HIGH CURRENT LEAKAGE**

- ▶ Failure to follow this warning could result in property damage, severe personal injury, or death. Grounding is essential before connecting electrical supply.

**CAUTION: CONTAINS REFRIGERANT**

- ▶ Failure to follow proper procedures can result in personal illness or injury or severe equipment damage. System contains oil and refrigerant under high pressure. Recover refrigerant to relieve pressure before opening system.

**WARNING:**

- ▶ This product can expose you to chemicals including Lead and Lead components, which are known to the State of California to cause cancer and birth defects or other reproductive harm. For more information go to www.P65Warnings.ca.gov.

**CAUTION: INDOOR UNIT REQUIRED**

- ▶ The indoor units must be matched with TXV. The model of TXV can be changed according to the system capacity.

2 Unit Location Considerations

2.1 Unit Dimensions

Unit Dimensions	
Models	H x W x L (Inches)
BOVB36-18	24-15/16 x 29-1/8 x 29-1/8
BOVB60-18	33-3/16 x 29-1/8 x 29-1/8

Table 1

The unit's weight values are on the carton box.

When mounting the outdoor unit on a roof, be sure the roof will support the unit's weight. Properly selected isolation is recommended to prevent sound or vibration transmission to the building structure.

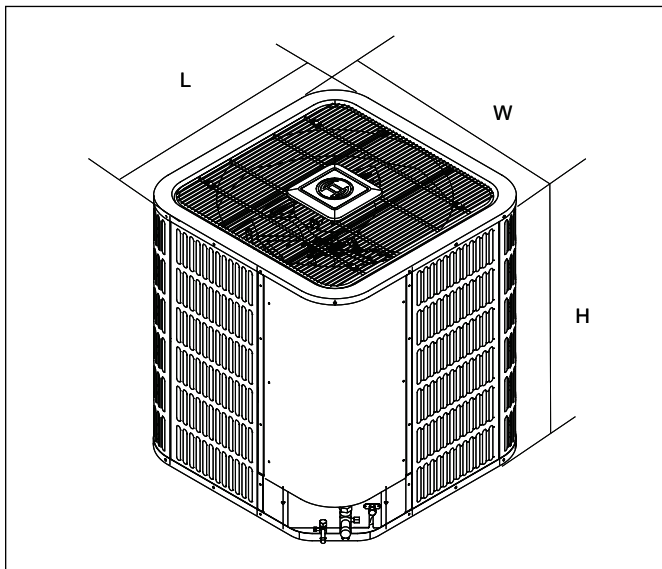

Figure 1

2.2 Refrigerant Piping Limits

System Capacity Model	Liquid Line	Suction Line	Total Equivalent Length - Feet			
			25	50	75	100
		Inch O.D.	Maximum Vertical Separation - Feet			
2 Ton	3/8 *	3/4 Std.	25	50	45	40
		5/8 Opt.	25	50	45	40
3 Ton	3/8 *	3/4 Std.	25	50	50	50
		5/8 Opt.	25	50	50	50
4 Ton	3/8 *	7/8 Std.	25	50	50	40
		3/4 Opt.	25	50	50	40
5 Ton	3/8 *	7/8 Std.	25	50	50	40
		3/4 Opt.	25	50	50	40
		1 1/8 Opt.	25	40	N/A	N/A

Table 2

* Standard line size is recommended;
 N/A: Application not recommended;
 Refrigerant charge: refer to Sec. 14

- ▶ Maximum line equivalent length = 100 feet.
- ▶ Maximum vertical equivalent length = 50 feet.
- ▶ Use only the line diameters indicated in Table 2.
- ▶ If the suction linesets are greater than 50 feet, do not use a larger suction line than recommended.

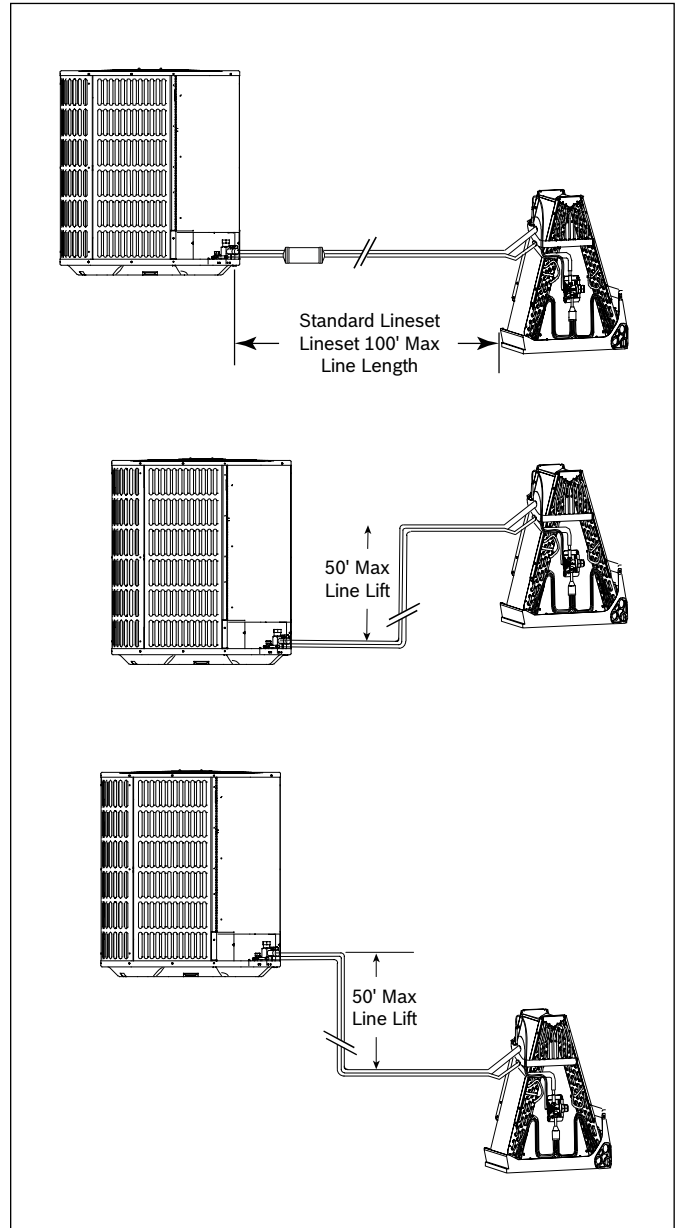

Figure 2

2.3 Location Restrictions

Ensure the top discharge area is unrestricted for at least 60 inches above the unit. Do not locate outdoor unit near bedrooms since normal operational sounds may be objectionable.

Position unit to allow adequate space for unobstructed airflow, wiring, refrigerant lines, and serviceability.

Allow a minimum of 12 in. clearance on one side of control board access panel to a wall and a minimum of 24 in. on the adjacent side of control board access panel.

Maintain a distance of 24 in. between units.

Position unit where water, snow, or ice from roof or overhang cannot fall directly on unit.

See Fig. 3 and Fig. 4.

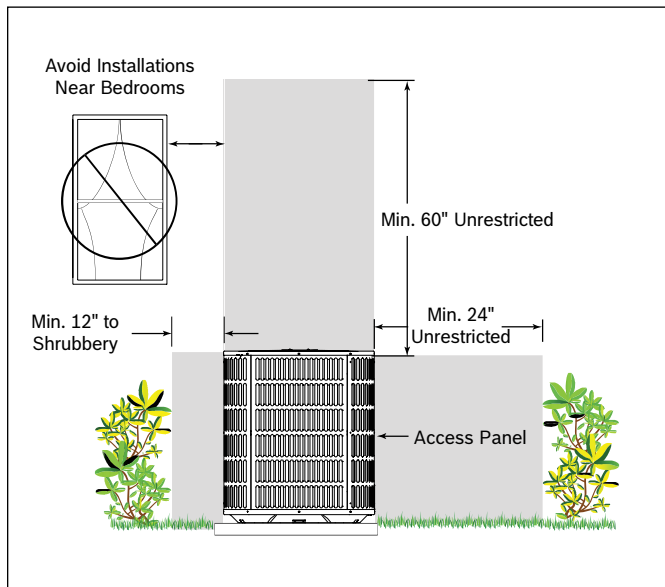

Figure 3

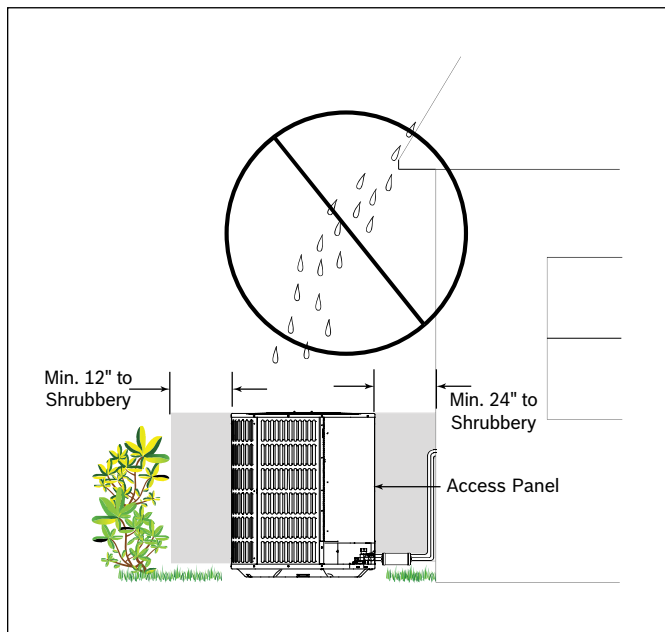

Figure 4

Cold climate considerations (heat pump only)

i Precautions must be taken for units being installed in areas where snow accumulation and prolonged below-freezing temperatures occur.

- ▶ Units should be elevated 3-12 inches above the pad or rooftop, depending on local weather. This additional height will allow drainage of snow and ice melted during defrost cycle prior to its refreezing. Ensure that drain holes in unit base pan are not obstructed, which could prevent the drainage of defrost water (Fig. 5).
- ▶ If possible, avoid locations that are prone to snow drifts. If not possible, a snow drift barrier should be installed around the unit to prevent a build-up of snow on the sides of the unit.

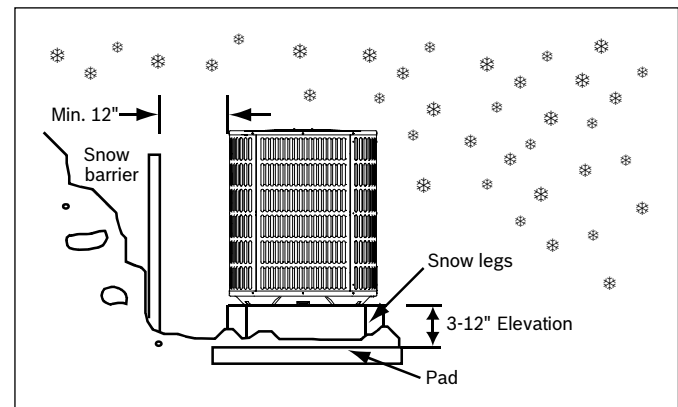

Figure 5

Corrosive Environment

NOTICE:

- ▶ Exposure to a corrosive environment may shorten the life of the equipment, corrode metal parts, and/or negatively affect unit performance.

Corrosive elements include, but are not limited to: sodium chloride, sodium hydroxide, sodium sulfate, and other compounds commonly found in ocean water, sulfur, chlorine, fluorine, fertilizers, and various chemical contaminants from industry/manufacturing plants. If installed in areas which may be exposed to corrosive environments, special attention should be given to the equipment placement and maintenance.

- ▶ Lawn sprinklers/hoses/waste water should not spray directly on the unit cabinet for prolonged periods of time.
- ▶ In coastal areas: locate the unit on the side of the building away from the waterfront.
- ▶ Fencing or shrubbery may provide some shielding protection to the unit, however minimum unit clearances must still be maintained.
- ▶ Approximately every three months, wash the outdoor coil and any exposed cabinet surfaces.

3 Unit Preparation

3.1 Prepare the Unit for Installation

- ▶ Check for damage and report promptly to the carrier any damage found to the unit (Fig. 6).
- ▶ The charge port can be used to ensure the refrigerant charge has been retained during shipment.

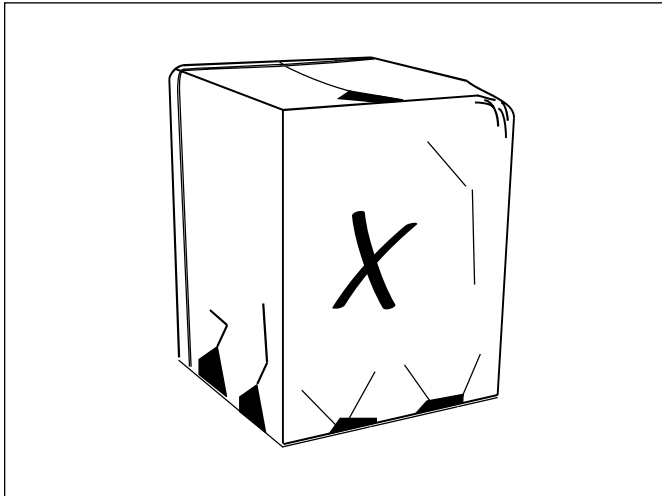

Figure 6

4 Setting the Unit

4.1 Pad Installation

When installing the unit on a support pad, such as a concrete slab, consider the following:

- ▶ The pad must be at least 1-2" larger than the unit on all sides.
- ▶ The pad must be separated from any structure.
- ▶ The pad must be level.
- ▶ The pad must be high enough above grade to allow for drainage.
- ▶ The pad location must comply with National, State, and local codes.



These instructions are intended to provide a method to tie-down system to cement slab as a securing procedure for high wind areas. Check local codes for tie-down methods and protocols.

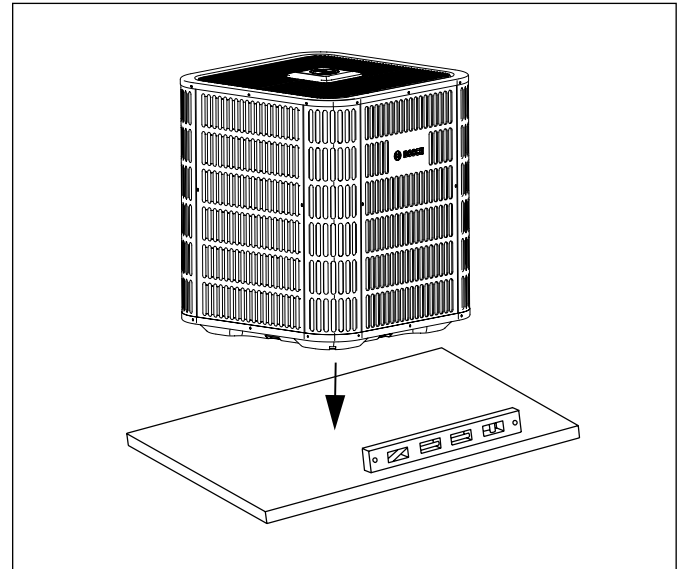

Figure 7

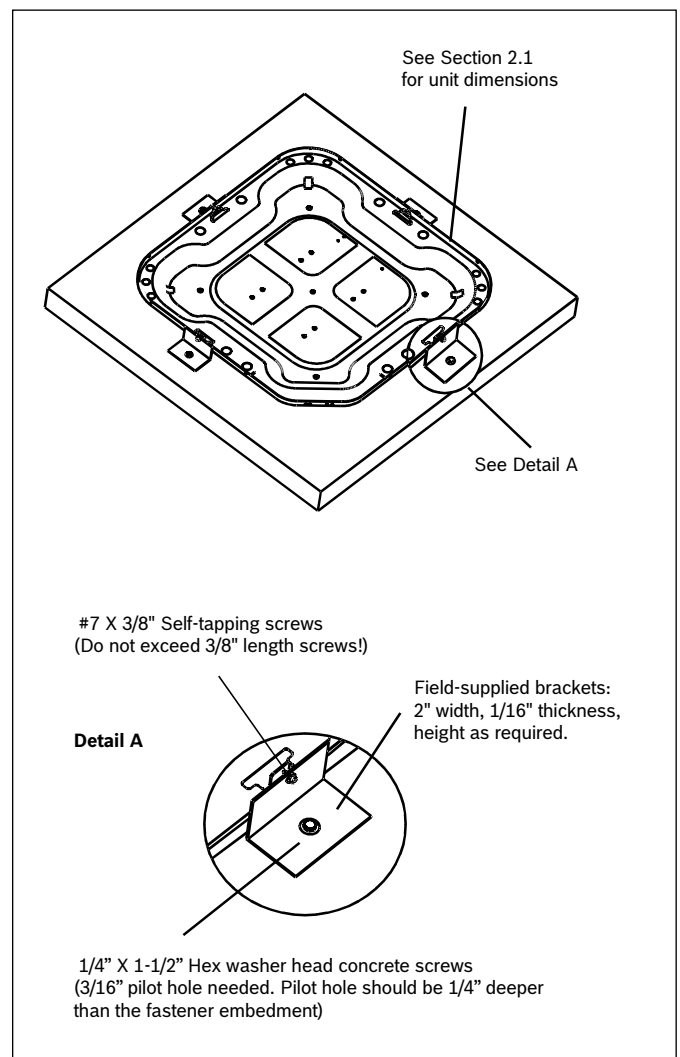

Figure 8

5 Refrigerant Line Considerations

5.1 Refrigerant Line and Service Valve Connection Sizes

Models	Suction Line	Liquid Line	Suction Line Connection	Liquid Line Connection
	Dimensions in inches			
BOVB36-18	3/4	3/8	3/4	3/8
BOVB60-18	7/8	3/8	7/8	3/8

Table 3

5.2 Required Refrigerant Line Length

Determine required line length (Fig. 9). Refer to Section 2.2.

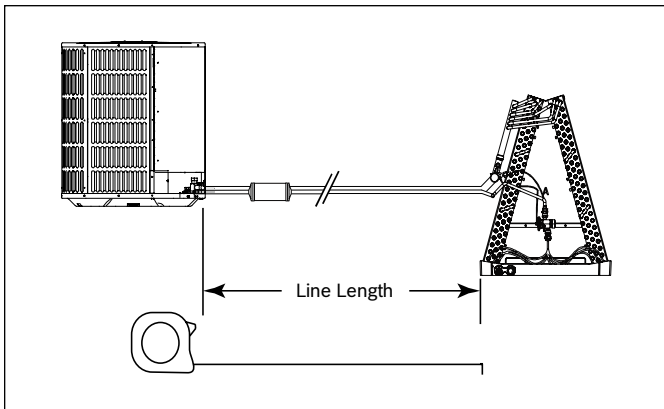

Figure 9

5.3 Refrigerant Line Insulation

i The Suction Line must always be insulated. DO NOT allow the Liquid Line and Suction Line to come in direct (metal to metal) contact.

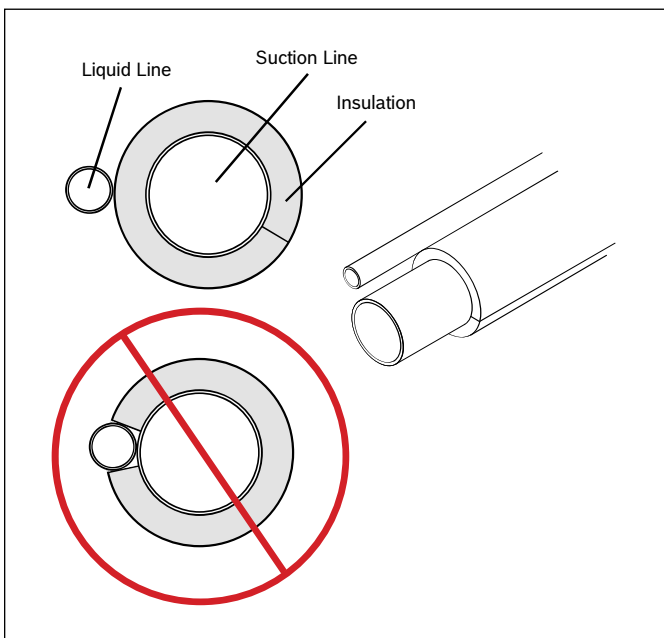

Figure 10

5.4 Reuse Existing Refrigerant Lines



CAUTION: MINOR TO MODERATE BURNS

- ▶ If using existing refrigerant lines, make certain that all joints are brazed, not soldered.

For retrofit applications, where the existing refrigerant lines will be used, the following precautions should be taken:

- ▶ Ensure that the refrigerant lines are the correct size. Refer to Section 2.2 and Table 2.
- ▶ Ensure that the refrigerant lines are free of leaks, acid, and oil.



The manufacturer recommends installing only approved matched indoor and outdoor systems. All of the manufacturer's split systems are AHRI rated only with TXV indoor systems. The benefits of installing approved matched indoor and outdoor split systems are maximum efficiency, optimum performance and the best overall system reliability.

6 Refrigerant Line Routing

6.1 Precautions



Take precautions to prevent noise within the building structure due to vibration transmission from the refrigerant lines. For example:

- ▶ When the refrigerant lines have to be fastened to floor joists or other framing in a structure, use isolation type hangers.
- ▶ Isolation hangers should also be used when refrigerant lines are run in stud spaces or enclosed ceilings.
- ▶ Where the refrigerant lines run through a wall or sill, they should be insulated and isolated.
- ▶ Isolate the lines from all ductwork.
- ▶ Minimize the number of 90° turns.



Comply with National, State, and local codes when isolating linesets from joists, rafters, walls, or other structural elements.

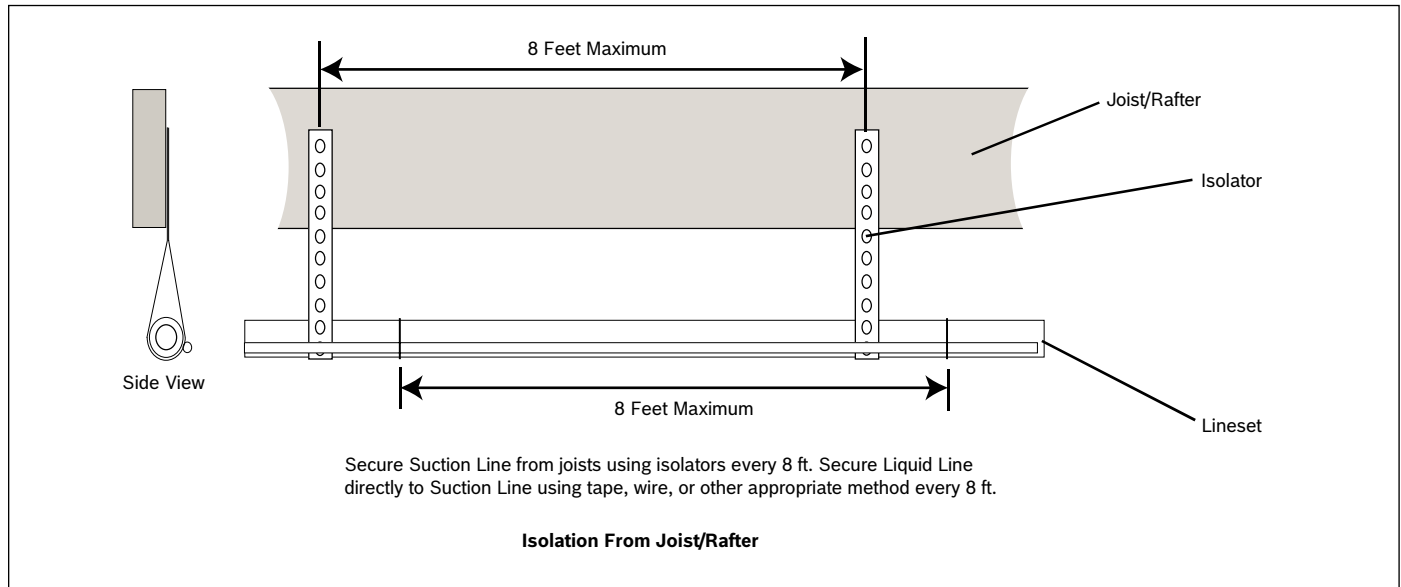

Figure 11

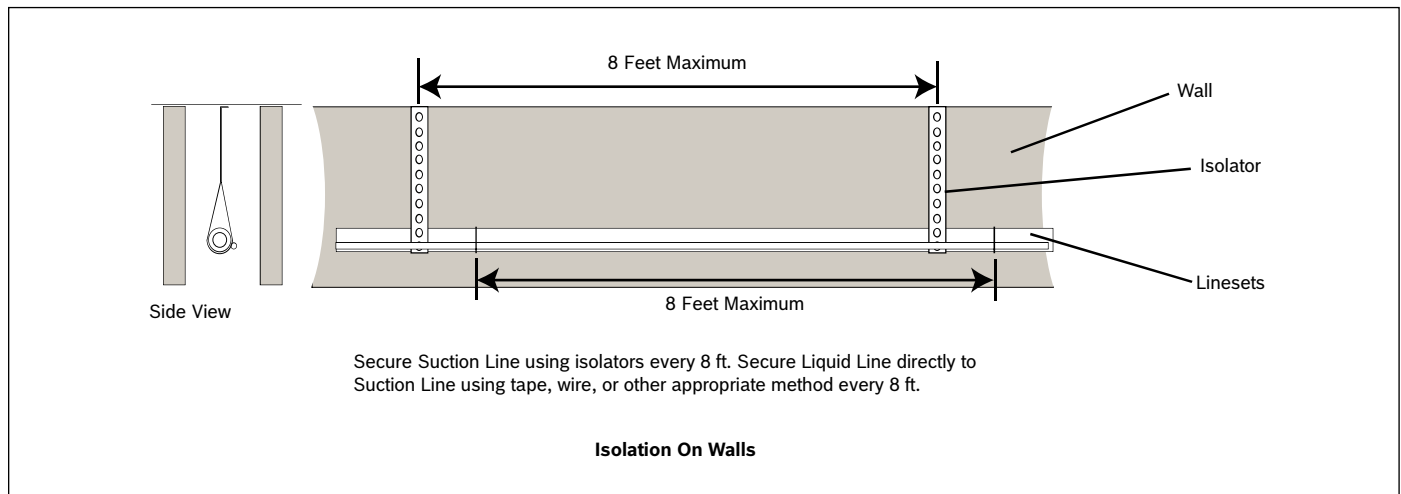

Figure 12

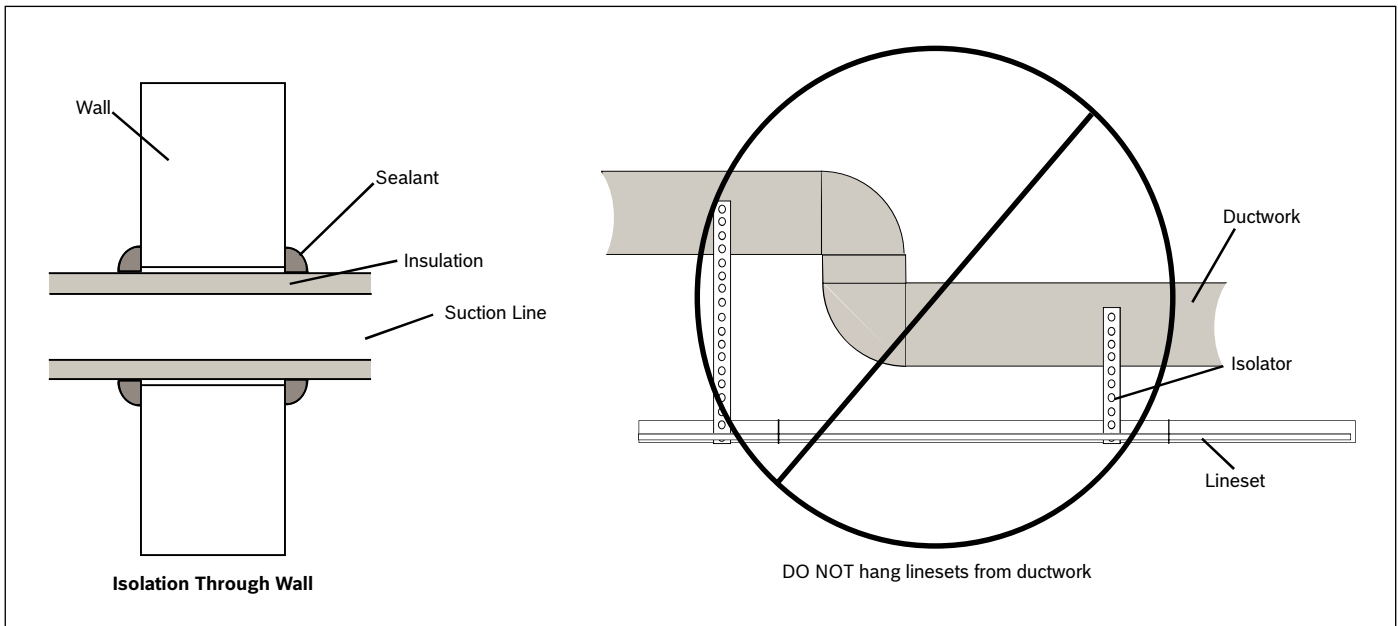

Figure 13

7 Refrigerant Line Brazing

7.1 Braze The Refrigerant Lines

1. Remove caps or plugs. Use a deburring tool to deburr the pipe ends. Clean both internal and external surfaces of the tubing using an emery cloth.

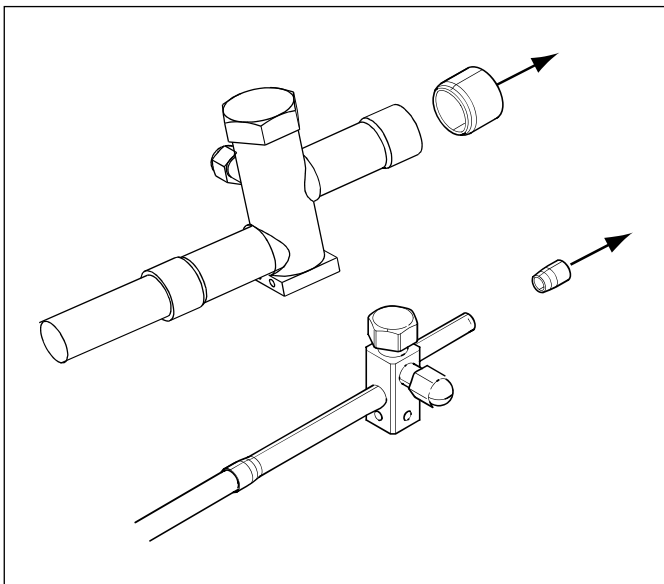

Figure 14

2. Remove the pressure tap cap from both service valves.

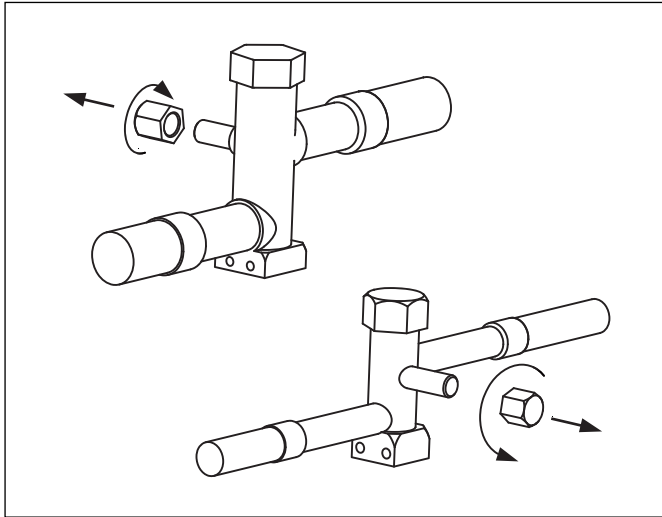

Figure 15

3. Purge the refrigerant lines and indoor coil with dry nitrogen.

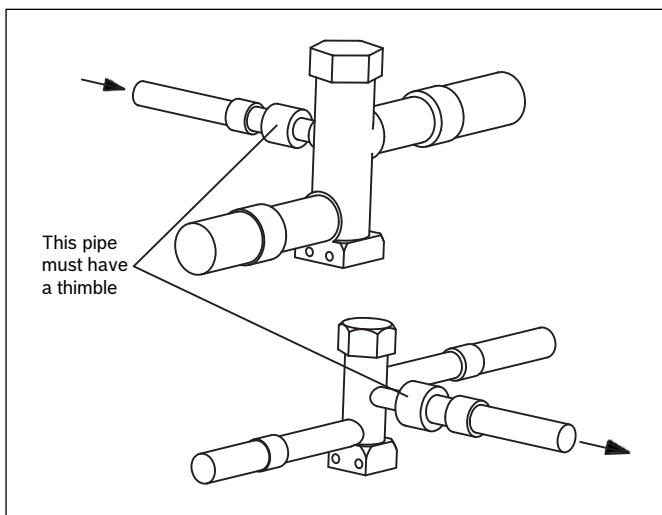

Figure 16

4. Wrap a wet rag around the valve body to avoid heat damage and continue the dry nitrogen purge (Fig. 17).
 Braze the refrigerant lines to the service valves.
 Braze the filter drier to the Liquid Line.

NOTICE:

- ▶ All units come standard with a bi-flow filter drier. Braze the filter drier to the liquid line, using caution not to push the refrigerant line too hard past the stop within the filter drier (this could damage the drier).

Continue the dry nitrogen purge. Do not remove the wet rag until all brazing is completed.



Remove the wet rag before stopping the dry nitrogen purge.

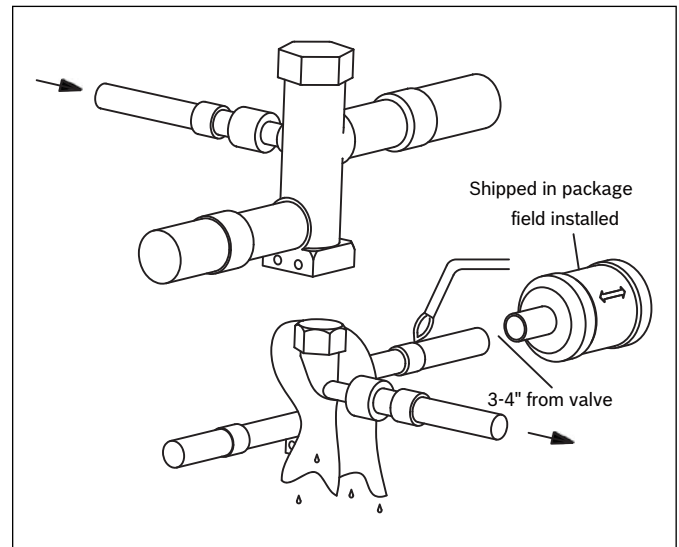

Figure 17

5. Replace the pressure tap caps after the service valves have cooled.

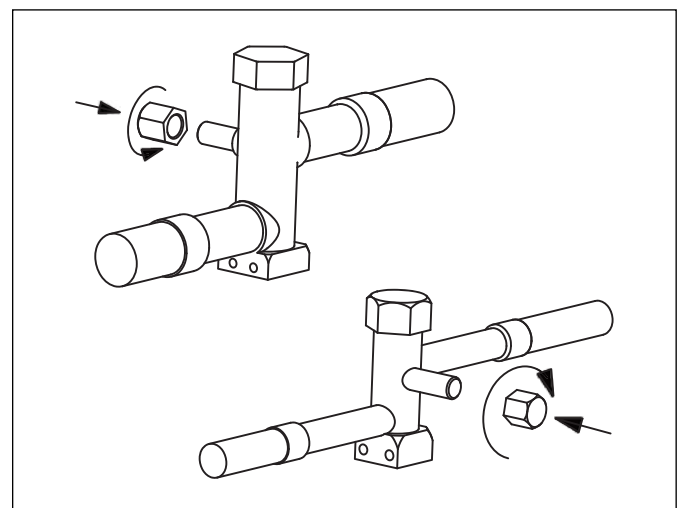

Figure 18

8 Refrigerant Line Leak Check

8.1 Check For Leaks

1. Pressurize the refrigerant lines and evaporator coil to 150 PSIG using dry nitrogen.

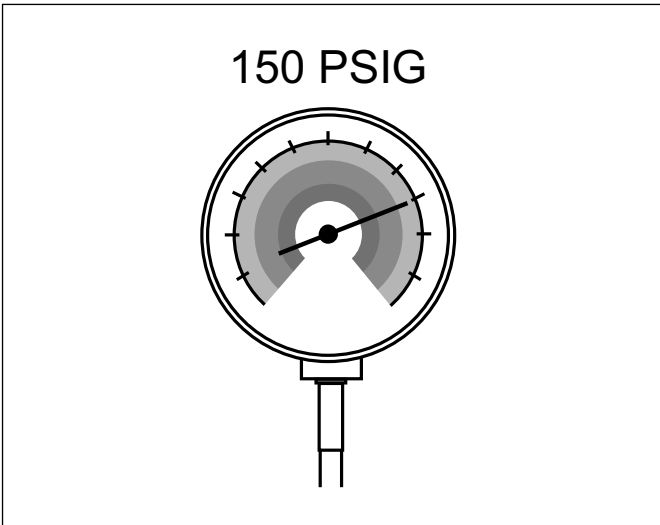

Figure 19

2. Check for leaks by using a soapy solution or bubbles at each brazed location.

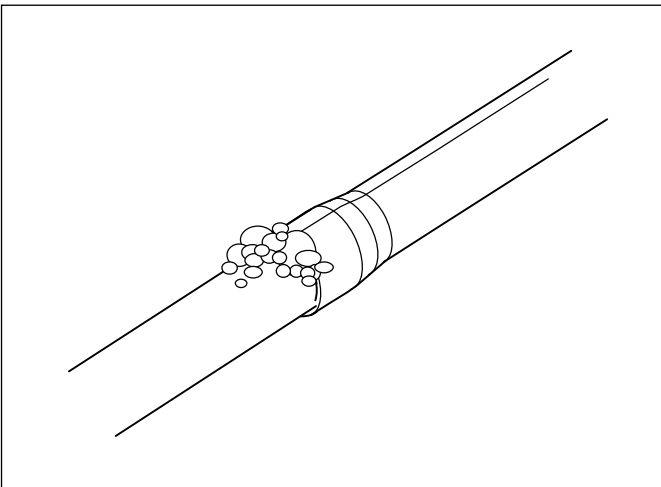

Figure 20

9 Evacuation

9.1 Evacuate the Refrigerant Lines and Indoor Coil



Do not open the service valves until the refrigerant lines and indoor coil leak check and evacuation are complete.

1. Evacuate until the micron gauge reads no higher than 350 microns, then close the valve to the vacuum pump.

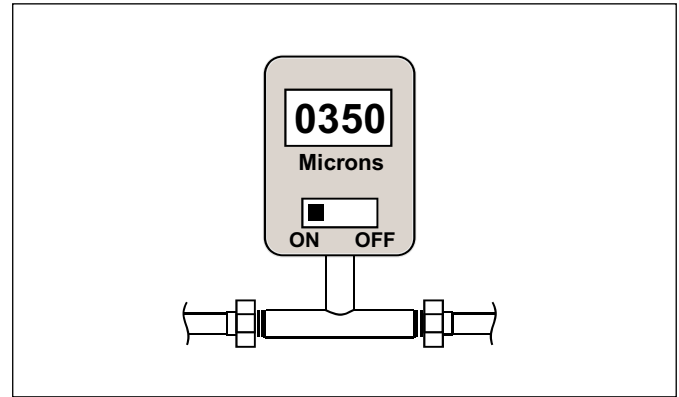

Figure 21

2. Observe the micron gauge. Evacuation is complete if the micron gauge does not rise above 500 microns in one (1) minute.

Once evacuation is complete, turn off the vacuum pump and micron gauge, and close the valves on the manifold gauge set.



Figure 22

10 Service Valves

10.1 Open the Service Valves



WARNING: MODERATE TO SEVERE BURNS

- ▶ Extreme caution must be exercised when opening the Liquid Line Service Valve. Turn counterclockwise until the valve stem just touches the rolled edge. No torque is required. Failure to follow this warning will result in abrupt release of system charge and may result in personal injury and /or property damage.



Leak check and evacuation must be completed before opening the service valves. The brazed lineset valves should be used for leak checking and vacuuming. Using the separate suction port for this process will result in loss of charge.



The Suction Service Valve must be opened first BEFORE opening the Liquid Service Valve.

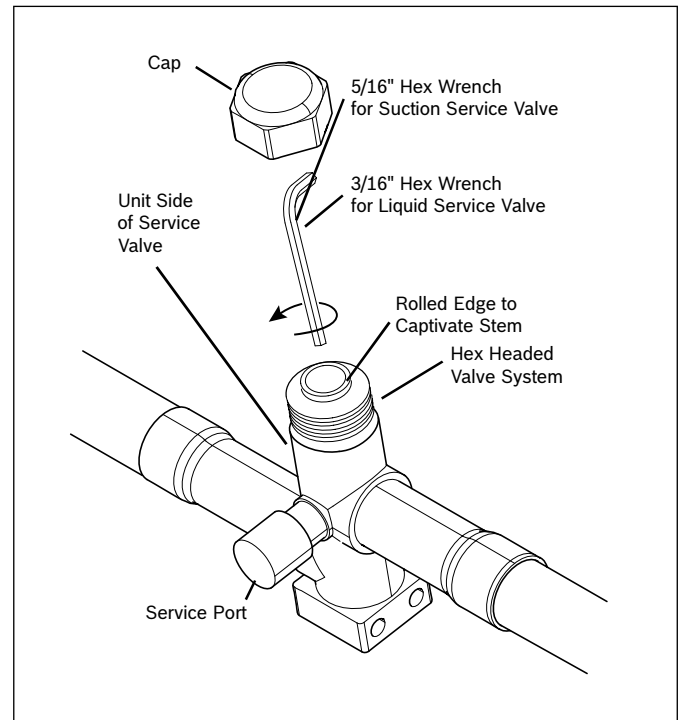

Figure 23

1. Remove Service Valve Cap (Fig. 23).
2. Fully insert hex wrench into the stem and back out counterclockwise until valve stem just touches the rolled edge (approximately five (5) turns).
3. Replace the Valve Stem Cap to prevent leaks. Finger tighten plus an additional 1/6 turn.
4. Repeat STEPS 1 - 3 for Liquid Service Valve.

11 Electrical - Low Voltage

11.1 Low Voltage Maximum Wire Length

Table 4 defines the maximum total length of low voltage wiring from the outdoor unit, to the indoor unit, and to the thermostat.

24 Volts - Wire size	Max. Wire Length
18 AWG	150 Ft.
16 AWG	225 Ft.
14 AWG	300 Ft.

Table 4

11.2 Low Voltage Hook-Up Diagrams

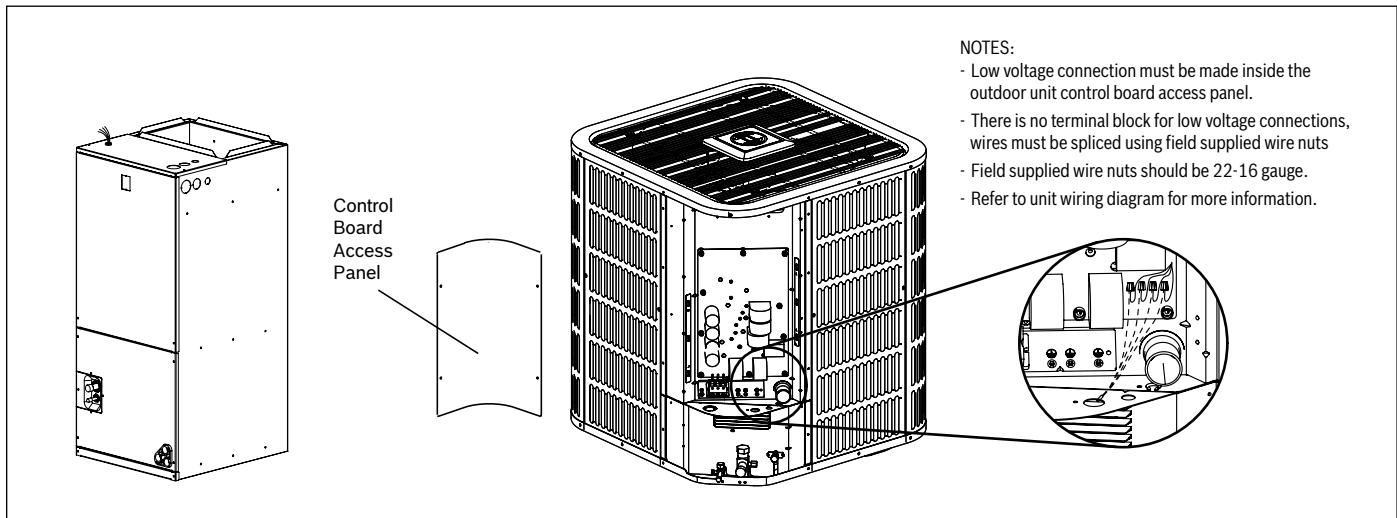

NOTES:

- Low voltage connection must be made inside the outdoor unit control board access panel.
- There is no terminal block for low voltage connections, wires must be spliced using field supplied wire nuts
- Field supplied wire nuts should be 22-16 gauge.
- Refer to unit wiring diagram for more information.

Figure 24 Low Voltage Unit Connections

11.3 Thermostat Wiring Diagrams

- ▶ Be sure power supply agrees with equipment nameplate.
- ▶ Power wiring and grounding of equipment must comply with local codes.
- ▶ Low voltage wiring to be minimum No. 18 AWG conductor.
- ▶ “- - - - -” represents Field installed electric auxiliary heat connection
- ▶ Single-stage auxiliary heating supported by 2H thermostat
- ▶ Twin-stage auxiliary heating supported by 3H thermostat
- ▶ W1: The first stage of field installed electric auxiliary heat.
- ▶ W2: The second stage of field installed electric auxiliary heat.
- ▶ The outdoor unit W signal is connected to first or second stage electric auxiliary heat.

i Dashed lines in the following thermostat wiring diagrams refer to optional wiring (wiring for Electric Heat). For thermostat wiring please refer to the Owner’s Manual of the thermostat.

i B terminal to be connected with thermostat (O/B) wiring. Reversing valve energizes in heating.

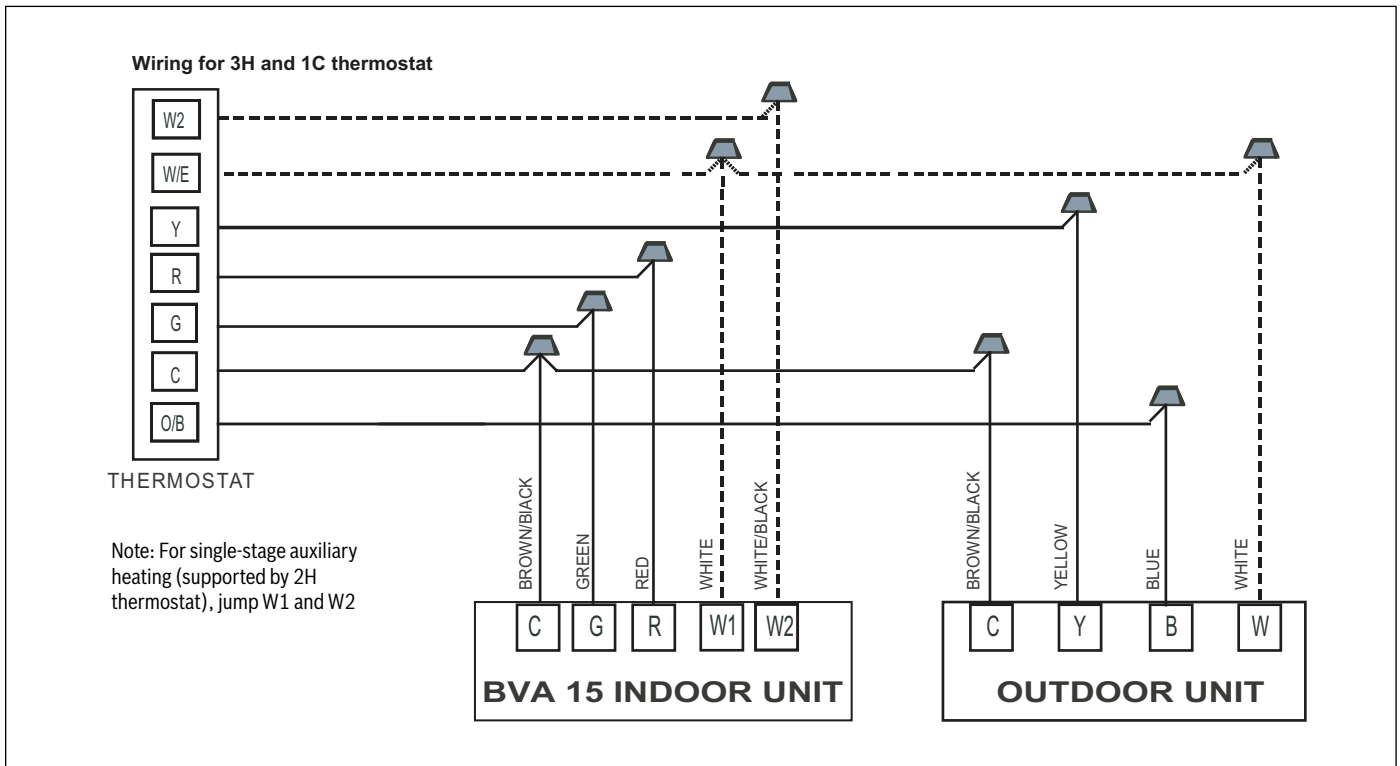

Figure 25 Thermostat Wiring Diagram for BOVB 18/BVA 15 Matched System

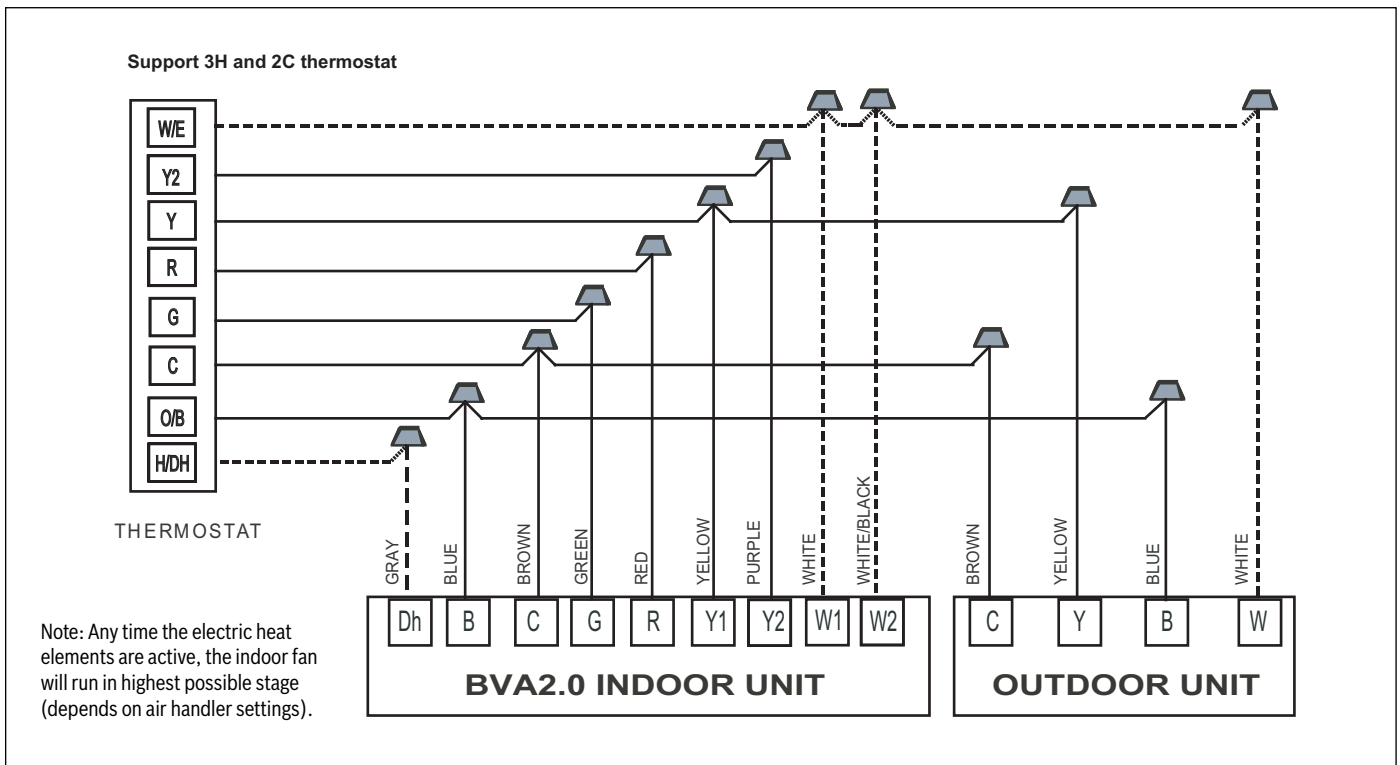

Figure 26 Thermostat Wiring Diagram for BOVB 18/BVA2.0 Matched System

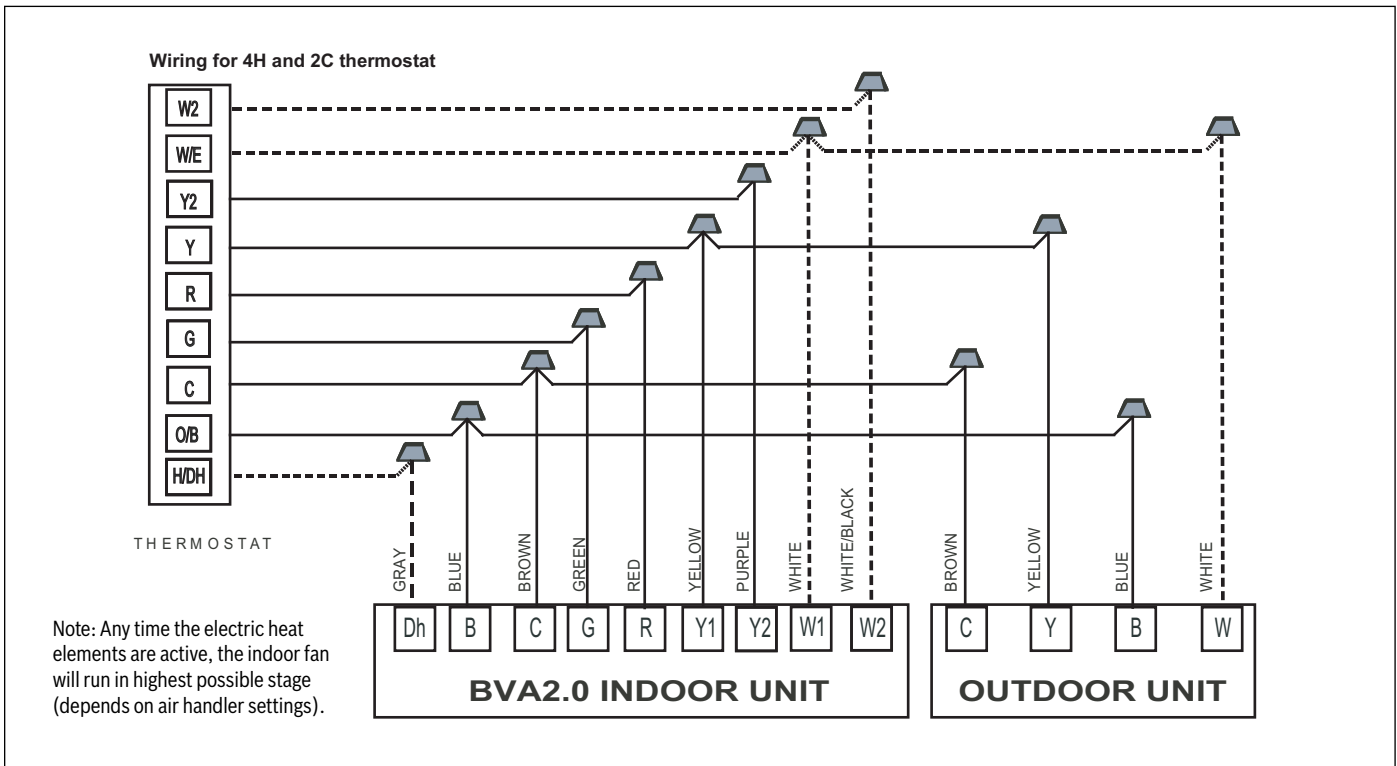

Figure 27 Thermostat Wiring Diagram for BOVB 18/BVA2.0 Matched System

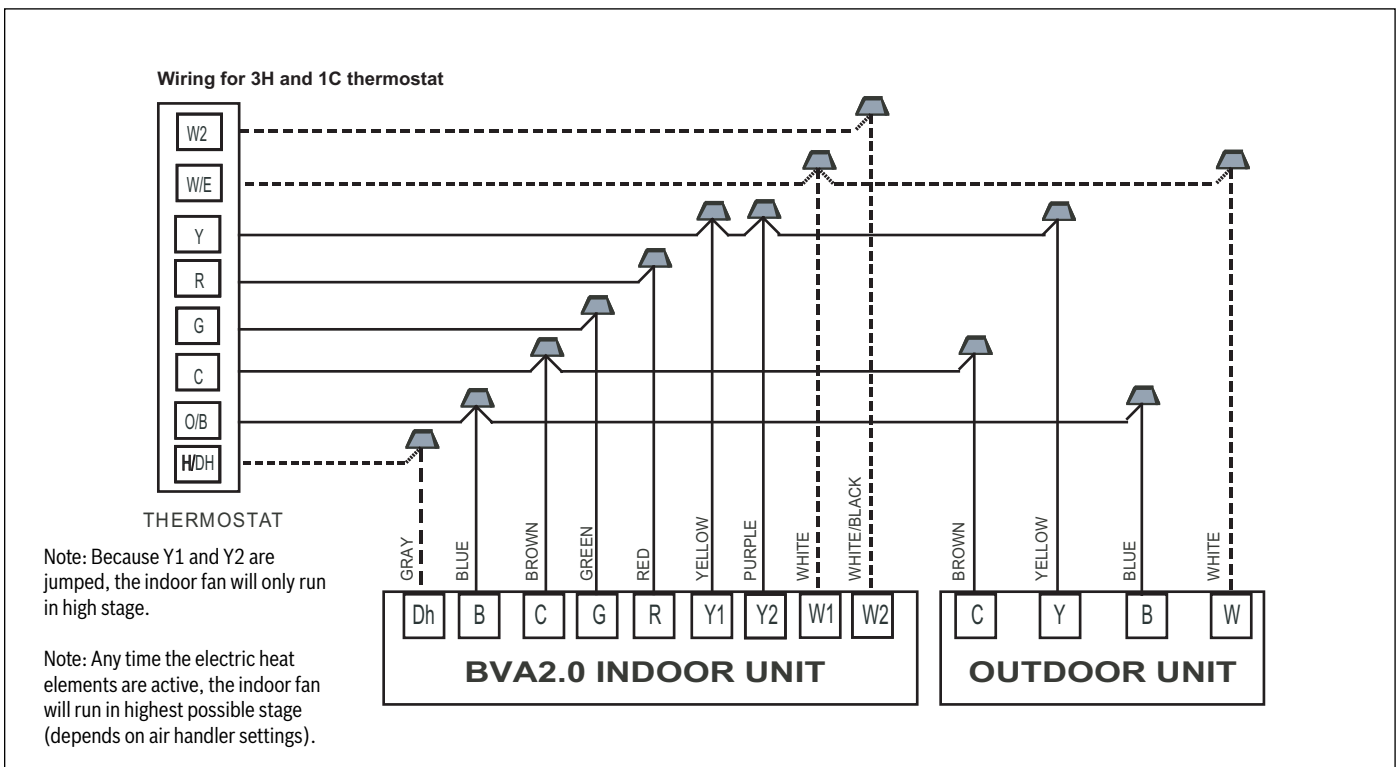

Figure 28 Thermostat Wiring Diagram for BOVB 18/BVA2.0 Matched System

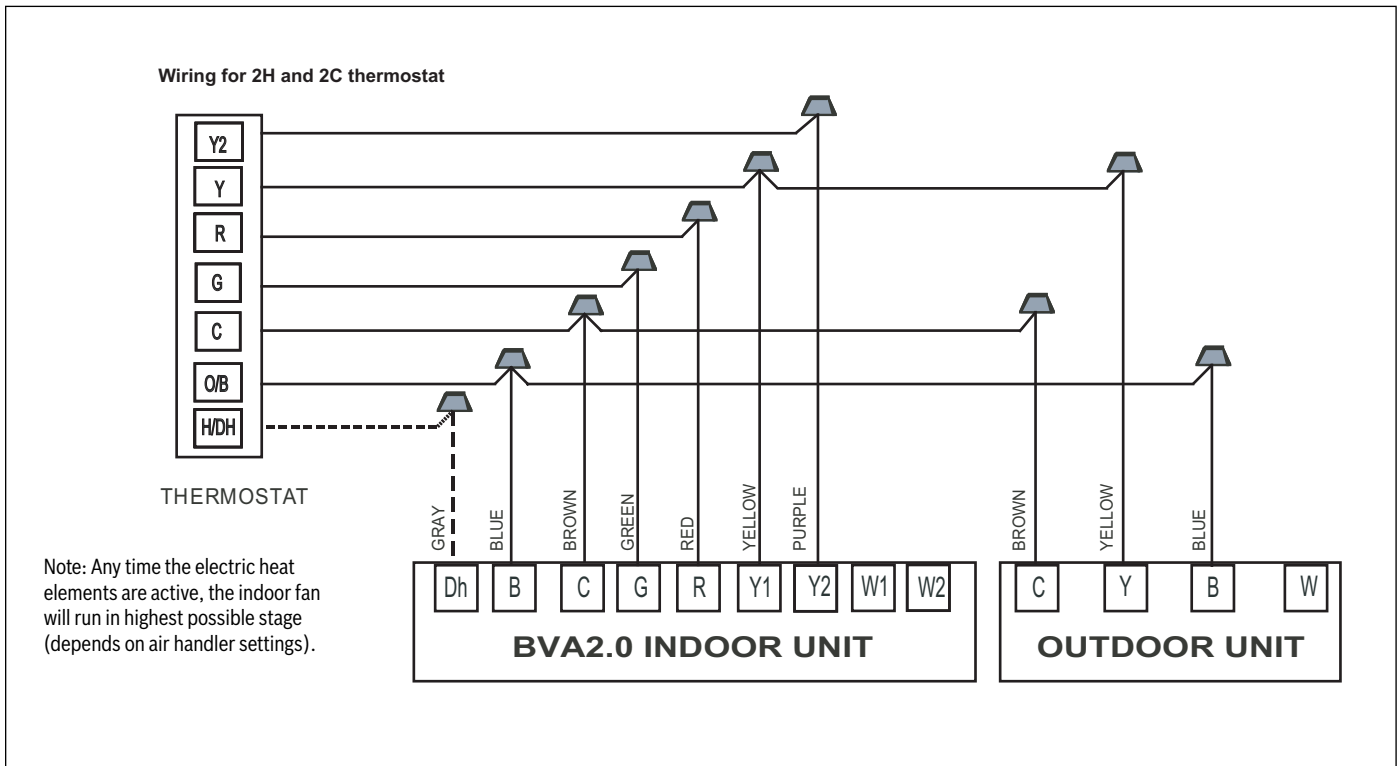

Figure 29 Thermostat Wiring Diagram for BOVB 18/BVA2.0 Matched System

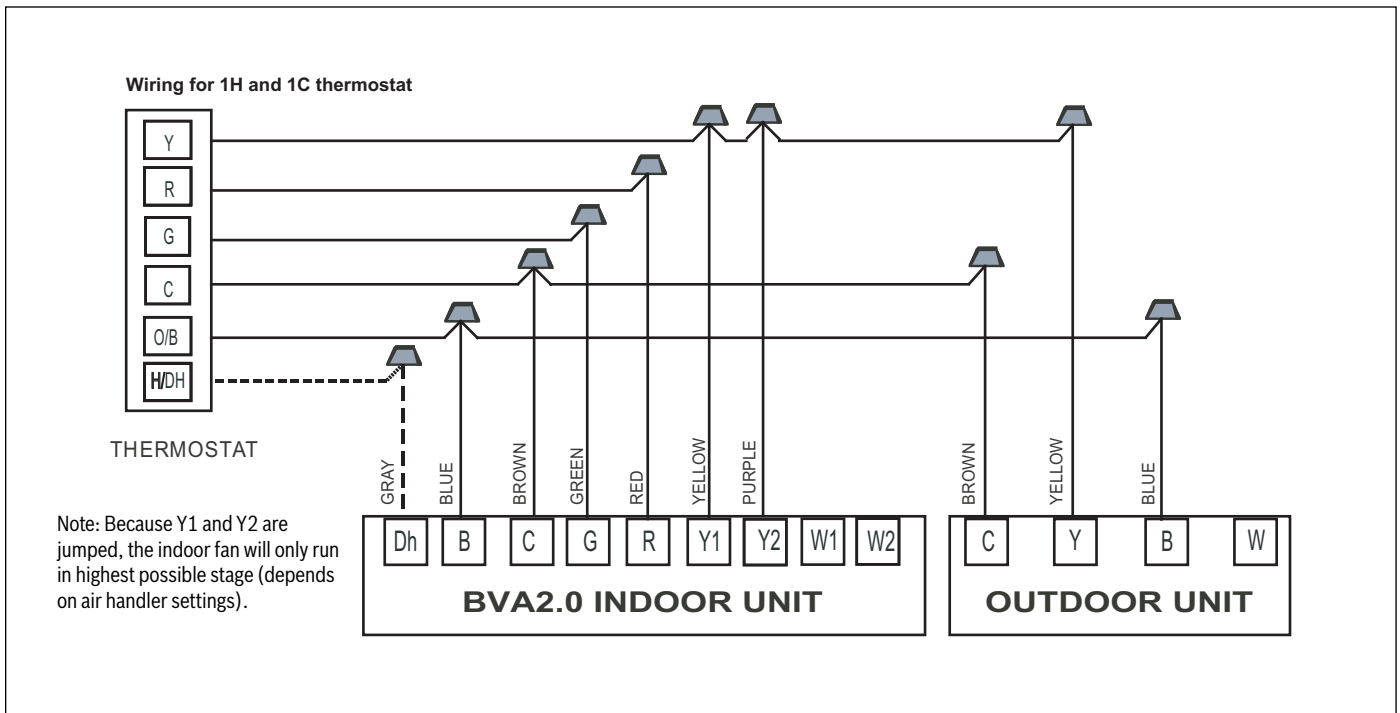

Figure 30 Thermostat Wiring Diagram for BOVB 18/BVA2.0 Matched System

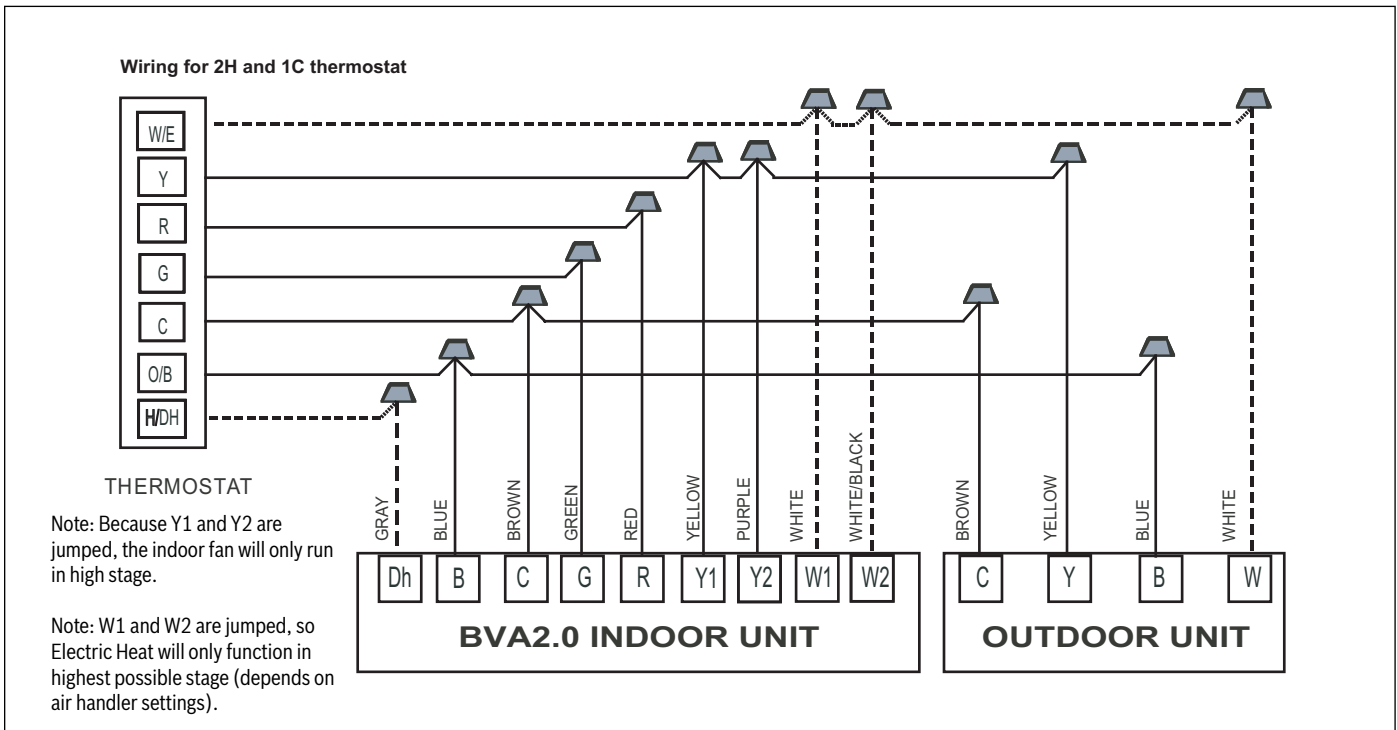

Figure 31 Thermostat Wiring Diagram for BOVB 18/BVA2.0 Matched System

12 Electrical - High Voltage

12.1 High Voltage Power Supply



WARNING: LIVE ELECTRICAL COMPONENTS!

- ▶ During installation, testing, servicing, and trouble shooting of this product, it may be necessary to work with live electrical components. Failure to follow all electrical safety precautions when exposed to live electrical components could result in death or serious injury.

The high voltage power supply must match the equipment nameplate (208/230V, 1PH, 60Hz).



WARNING:

- ▶ Electrical power wiring must comply with national, state, and local codes.

Follow instructions on unit wiring diagram located on the inside of the control box access panel and refer to wiring diagram in this IOM.

12.2 High Voltage Disconnect Switch

Install a separate disconnect switch at the outdoor unit.

Field supplied flexible electrical conduit must be used for high voltage wiring.

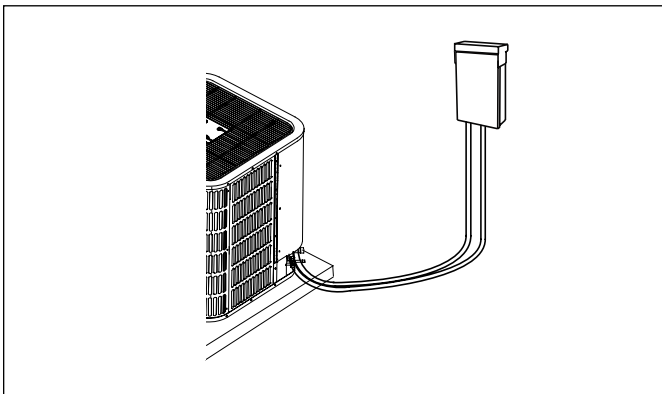

Figure 32

12.3 High Voltage Ground

Ground the outdoor unit per national, state, and local code requirements.

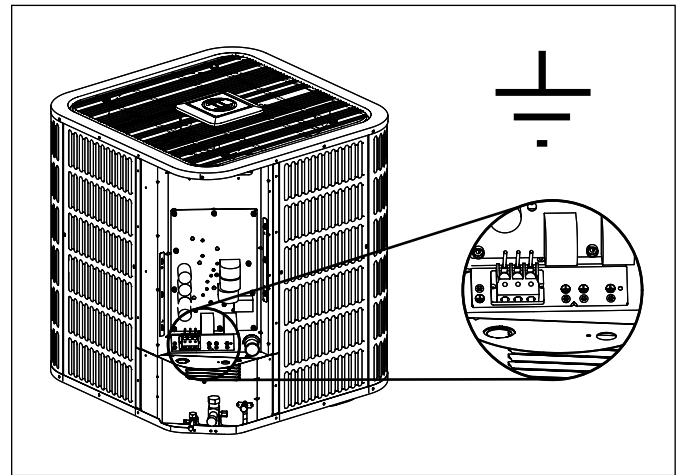

Figure 33

13 Start Up

13.1 System Start Up

1. Ensure Sections 7, 8, 9, 10, 11, and 12 have been completed.
2. Set System Thermostat to OFF.



Figure 34

3. Turn on disconnect to apply power to the indoor and outdoor units.

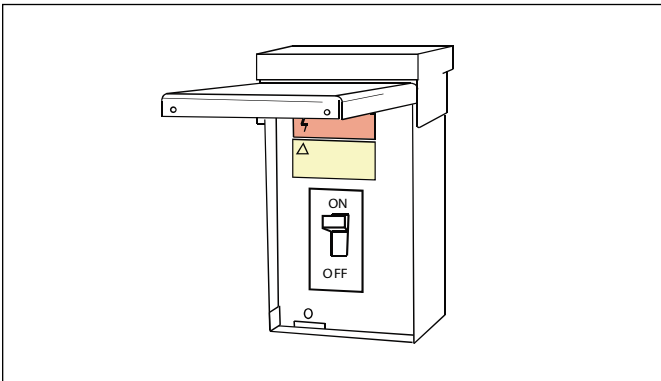

Figure 35

4. Upon initial unit installation, wait one (1) hour before starting the unit if compressor crankcase heater is used and the outdoor ambient temperature is below 70 °F.

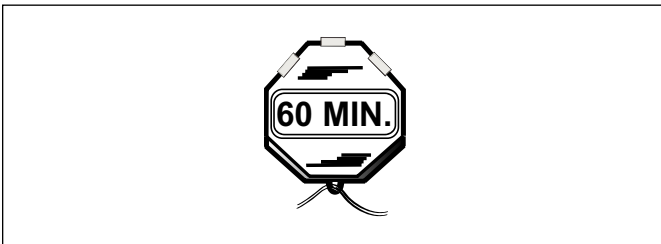

Figure 36

5. Set system thermostat to ON.



Figure 37

14 System Charge Adjustment

14.1 Charging: Weigh-In Method

Use weigh-in method during the initial installation, or anytime a system charge is being replaced. Weigh-in method can also be used when power is not available to the equipment site or operating conditions (indoor/outdoor temperatures) are not in range to verify with the subcooling charging method.

Model	Factory Charge	Charge multiplier for interconnecting refrigerant tube length
3 Ton	7 lbs 9 oz	0.6 oz/ft
5 Ton	10 lbs 10 oz	0.6 oz/ft

Table 5

i The factory charge in the outdoor unit is sufficient for 15 feet of standard size interconnecting liquid line.

New Installations – Calculating additional charge for lineset greater than 15 ft.

- Total Line Length (ft) = _____ (a)
- Standard Lineset (ft) = 15 (b)
- (a) minus (b) = _____ (c)
- Refrigerant Multiplier = 0.6 oz/ft (d)
- Refrigerant Adder (c*d) = _____ (e)*

*If lineset is less than 15 ft, (e) = 0

Sealed-System Repairs – Calculating total system charge.

- Total Line Length (ft) = _____ (a)
- Standard Lineset (ft) = 15 (b)
- (a) minus (b) = _____ (c)
- Refrigerant Multiplier = 0.6 oz/ft (d)
- Refrigerant Adder (c*d) = _____ (e)*
- Factory Charge (namplate) = _____ (f)
- Total System Charge (e+f) = _____

*If lineset is less than 15 ft, (e) = 0

i The only mode approved for validating system charge is while in Cooling "Force Mode". Outdoor temperature must be between 55°F and 120°F with indoor temperature kept between 70°F and 80°F.

14.2 Subcooling Charging And Refrigerant Adjustment In Cooling (Above 55°F Outdoor Temp.)

- Check the outdoor ambient temperatures.

Subcooling (**in cooling mode**) is the only recommended method of charging above 55°F outdoor ambient temperatures.

For outdoor ambient temperatures below 55°F use weigh-in charge method.

i It is important to return in the spring or summer to accurately charge the system in the cooling mode when outdoor ambient temperature is above 55°F.

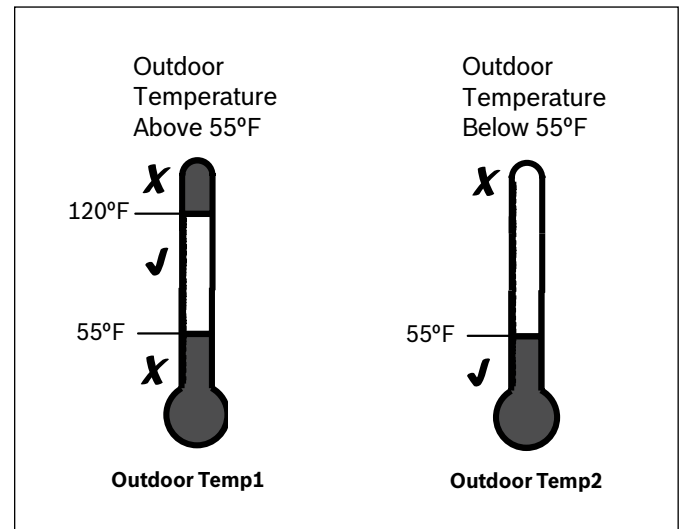

Figure 38

For best results, the indoor temperature should be kept between 70°F and 80°F during the install.

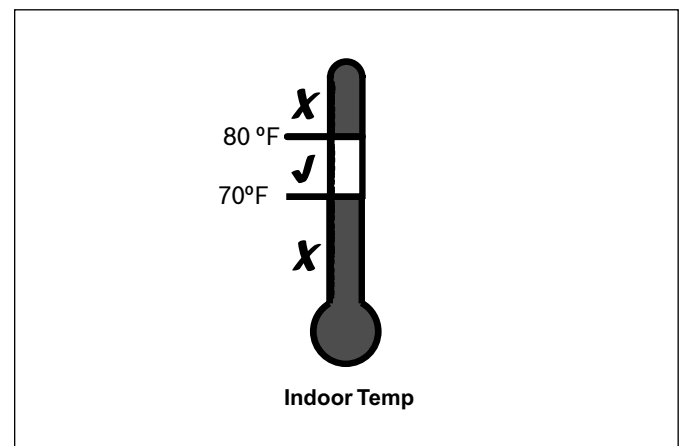

Figure 39

- Ensure Sections 7,8,9,10,11,12 and 13 have been completed.

3. Stabilize the system.

After **starting the system in cooling mode**, short press “FORCE” button, and “+” symbol should appear. System may take 10 minutes to ramp up. Operate the system for a minimum of twenty (20) minutes.

i After a twenty (20) minute stabilization period operating at 100% capacity (i.e. once the compressor reaches the frequency shown in Table 6), maintain continuous operation while adjusting refrigerant charge. After adjusting, operate system for a minimum of five (5) minutes for system to stabilize, otherwise repeat step 3.

Compressor Frequency in Force Mode in Cooling				
ODU Capacity	2TON	3TON	4TON	5TON
Frequency (HZ)	56	76	56	66

Table 6



Figure 40

4. Calculate superheat value (According to Table 7)

- ▶ Measured Suction Line Temp = _____°F
- ▶ Measured Suction Line Pressure = _____ PSIG
- ▶ Calculate superheat value = _____°F

i For indoor unit with adjustable TXV, set subcooling and adjust **superheat** via adjustable TXV according to Table 9. For indoor unit with non-adjustable TXV, check the superheat and set correct subcooling according to superheat, refer to Table 9.

5. Calculate subcooling value (According to Table 8)

- ▶ Measured Liquid Line Temp. = _____°F
- ▶ Measured Liquid Line Pressure = _____ PSIG
- ▶ Calculate subcooling value = _____°F

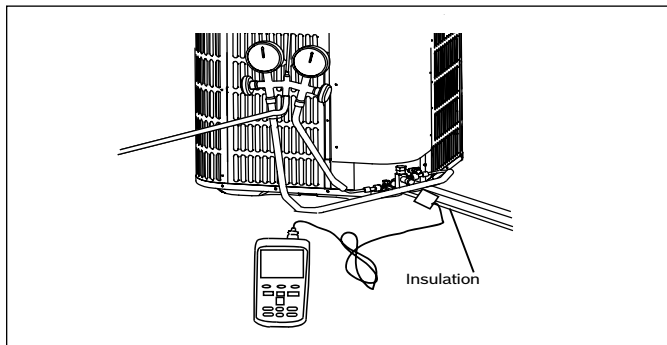

Figure 41

i If calculated subcooling value is lower than the design subcooling value (Table 9), please add refrigerant. Repeat steps 3 through 5.

i If the superheat is out of range, refer to Troubleshooting section of this IOM.

Suction Temp (°F)	Final Superheat (°F)								
	6	8	10	12	14	16	18	20	22
	Suction Gauge Pressure (PSI)								
40	105	101	97	93	89	86	82	78	75
42	109	105	101	97	93	89	86	82	78
44	114	109	105	101	97	93	89	86	82
46	118	114	109	105	101	97	93	89	86
48	123	118	114	109	105	101	97	93	89
50	128	123	118	114	109	105	101	97	93
52	133	128	123	118	114	109	105	101	97
54	138	133	128	123	118	114	109	105	101
56	143	138	133	128	123	118	114	109	105
58	148	143	138	133	128	123	118	114	109
60	153	148	143	138	133	128	123	118	114
62	159	153	148	143	138	133	128	123	118
64	164	159	153	148	143	138	133	128	123
66	170	164	159	153	148	143	138	133	128
68	176	170	164	159	153	148	143	138	133
70	182	176	170	164	159	153	148	143	138
72	188	182	176	170	164	159	153	148	143

Table 7 R-410A Refrigerant chart - Final Superheat

Liquid Temp (°F)	Final Subcooling (°F)							
	6	7	8	9	10	11	12	13
	Liquid Gauge Pressure (PSI)							
55	173	176	179	182	185	188	191	195
60	188	191	195	198	201	204	208	211
65	204	208	211	215	218	221	225	229
70	221	225	229	232	236	239	243	247
75	239	243	247	251	255	259	262	266
80	259	262	266	270	275	279	283	287
85	279	283	287	291	295	300	304	309
90	300	304	309	313	318	322	327	331
95	322	327	331	336	341	346	351	355
100	346	351	355	360	365	370	376	381
105	370	376	381	386	391	397	402	407
110	397	402	407	413	418	424	430	435
115	424	430	435	441	447	453	459	465
120	453	459	465	471	477	483	489	496
125	483	489	496	502	508	515	521	528

Table 8 R-410A Refrigerant chart - Final Subcooling

Design Subcooling		
Model	Subcooling/°F	Superheat/°F
24K/36K	8-12*	10-18*
	6-10	7-10
48K	6-10*	9-18*
	4-8	7-9
60K	6-10*	8-18*
	4-8	6-8

Table 9

* Optimized range for superheat/subcool

- Adjust refrigerant level to attain proper gauge pressure.

i **Add refrigerant** if the subcooling reading from Table 8 is lower than the designed value (Table 9).

- ▶ Connect gauges to refrigerant bottle and unit as illustrated (Fig. 41).
- ▶ Purge all hoses.
- ▶ Open tank.
- ▶ Stop adding refrigerant when subcooling matches the design value (Table 9).

i **Recover refrigerant** if the subcooling reading from Table 8 is higher than the design value (Table 9).

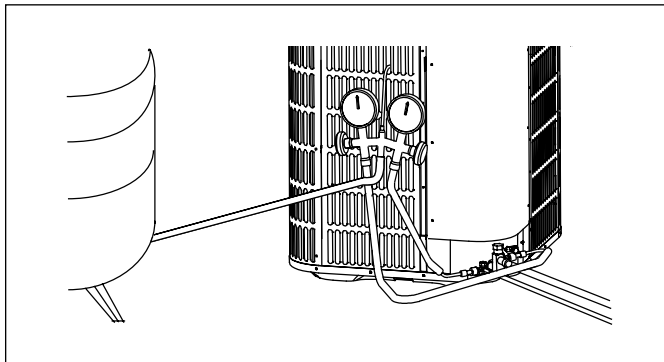

Figure 42

- Stabilize the system.
 - ▶ Wait 5 minutes for the system condition to stabilize between adjustments.

i When the subcooling matches the design value (Table 9), the system is properly charged.

- ▶ Remove gauges.
 - ▶ Replace service port caps to prevent leaks. Tighten finger tight plus an additional 1/6 turn.
- Record System Information for reference (Table 10). Record system pressures and temperatures after charging is complete.

Description	Value
Outdoor model number	
Measured Outdoor Ambient	°F
Measured Indoor Ambient	°F
Measured Liquid Line Temp	°F
Measured Suction Line Temp	°F
Liquid Gauge Pressure	PSIG
Suction Gauge Pressure	PSIG

Table 10

15 System Operation and Troubleshooting

15.1 Control Logic Description

- ▶ The variable speed system adopts the same 24VAC control as any conventional heat pump.
- ▶ The compressor's speed is controlled based on coil pressures monitored by the unit's pressure transducer. To ensure stable and adequate capacity, the compressor speed will modulate relative to evaporator pressure during cooling operation and relative to condensing pressure during heating operation. The target pressure can automatically adjust based on compressor operation so optimal capacity can be achieved. Target pressure can be manually adjusted (SW4) to achieve improved dehumidification and capacity demands.

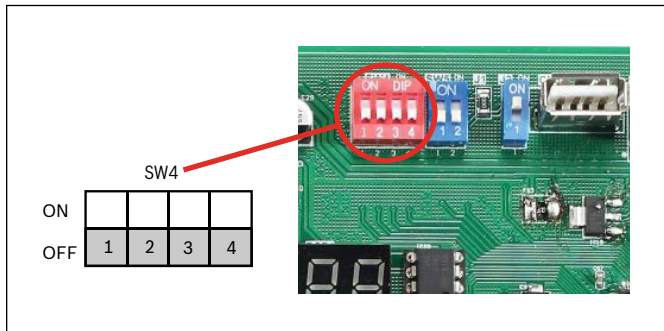

Figure 43

Switch		Description
SW4-1	ON	Unused
	OFF*	Must be set at "OFF" position
SW4-2	ON	Unused
	OFF*	Must be set at "OFF" position
SW4-3	ON	Adaptive capacity output disabled
	OFF*	Adaptive capacity output enabled
SW4-4	ON	Accelerated cooling/heating
	OFF*	Normally cooling/heating

Table 11

*Factory Default

- ▶ Adaptive capacity function is a "self-learning function" which allows a range of target coil temperatures to adapt for better unit operation and reduced short cycling.
- ▶ Accelerated cooling/heating function changes the initial target coil temperature to provide "enhanced comfort" by increasing unit capacity.

15.2 Sensors (Thermistors/Pressure Transducer)

- ▶ T3 = Outdoor Coil Temperature (Table 24)
 - High/Low temperature protection
 - Outdoor fan control (cooling mode)
 - Defrost control (heating mode)
- ▶ T4 = Ambient Temperature (Table 24)
 - Operating condition permission
 - Defrosting condition permission
 - Outdoor fan control (heating mode)
- ▶ T5 = Compressor Discharge Temperature (Table 25)
 - High/Low temperature protection
 - Electronic Expansion Valve (EEV) (ODU/heating mode only)
- ▶ TF = IPM Radiator Temperature
 - Inverter High Temperature Protection
- ▶ Pressure transducer
 - Compressor frequency control
 - Electronic Expansion Valve (EEV) control (heating mode only)
 - High pressure protection (heating mode)
 - Low pressure protection (cooling mode)

15.3 Pressure Equalizer Valve (PEV)

Used to balance the pressure in the system before compressor start up.

15.4 Defrost Description

- ▶ The Demand Defrost Control (DDC) monitors the ODU coil temperature using thermistor (T3). A second thermistor (T4) monitors outdoor ambient temperature. Based on these parameters, as well as accumulative run time and high pressure, the DDC calculates proper initiation of defrost.
- ▶ Any one of the below three conditions is required to enter defrost:
 1. The calculated temperature difference between the outdoor temperature (T4) and the coil temperature (T3) is called Delta T. After Delta T is achieved and continues for 3 minutes.
 - T4 ≥ 39°F, Delta T = 18°F
 - T4 ≥ 30°F, Delta T = 16°F
 - T4 ≥ 19°F, Delta T = 14°F
 - When T4 < 19°F, T3 < 9°F, accumulative compressor run time ≥ 80 minutes.
 2. After "Minimum Run Time" (MRT) is achieved. MRT is based on outdoor ambient temperature (T4), for example:
 - MRT is 4 hours when: T4 < 23°F
 - MRT is 2 hours when: 23°F ≤ T4 < 40°F
 3. After the high pressure saturation temperature drops below 82°F for 20 minutes.
- ▶ Defrost will terminate once outdoor coil temperature (T3) reaches 64°F for a period of 1 minute or defrost time has exceeded 8 minutes.

- ▶ Defrost Termination Settings (SW5) offers different defrost termination options for enhanced defrost for different geographical and outdoor conditions.

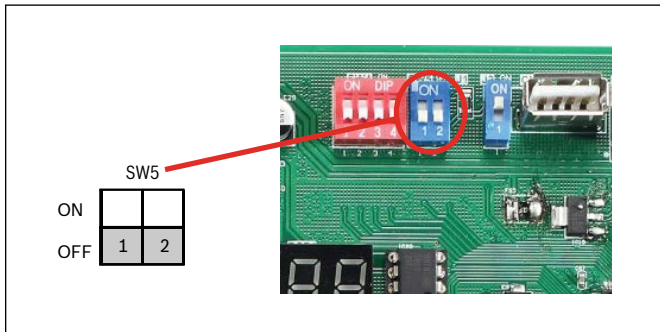

Figure 44

Defrosting Choice	SW5-1	SW5-2	Remarks
ON	Operating time is reduced by 10%	Defrosting extended for 60 seconds	
OFF	Normal	Normal	Default
Remarks	Enter defrost	Quit defrost	

Table 12

- ▶ Manual Defrost:
 1. System must have a call for heat and have been operating for a minimum of 8 minutes.
 2. Press "Force" button on inverter board for 6 seconds to begin forced defrost.
 3. Wait approximately 40 seconds for defrost to initiate.
 4. Once defrost initiates, the display will indicate "dF".
 5. Defrost test will terminate automatically, after which the display will indicate running speed.
 6. If a second defrost test is required, repeat steps 2-5 after 5 minutes.

15.5 Compressor Crankcase Heater Description

Refrigerant migration during the OFF cycle can result in noisy start-ups, therefore a CrankCase Heater (CCH) is used to minimize refrigerant migration thereby minimizing start-up noise and/or bearing "wash out". All CCHs must be installed on the lower half of the compressor shell. Its purpose is to warm the compressor during the OFF cycle, driving refrigerant from compressor. After extended shutdown periods in cold weather, it is recommended to allow CCH to be energized for at least 12 hours prior to compressor operation by applying line voltage to heat pump with thermostat OFF.

- ▶ CCH operation energizes:
 1. First time line voltage is applied and compressor discharge temperature $T5 < 53.6^{\circ}\text{F}$.
 2. Compressor stops running for 3 hours (outdoor ambient temperature $T4 < 41^{\circ}\text{F}$ OR compressor discharge temperature $T5 < 53.6^{\circ}\text{F}$).
- ▶ CCH operation de-energizes:
 1. Compressor discharge temperature $T5 \geq 60.8^{\circ}\text{F}$.
 2. Compressor start running.

15.6 Reversing Valve Operation

- ▶ Reversing valve energizes during heat mode and de-energizes in cool mode.



During a heat call on first time operation the unit will run about 1 minute in cooling to build up pressure for reversing valve to change.

15.7 Protection Functions

- ▶ Outdoor coil temperature protection (T3)
 - i. If $T3 > 143.6^{\circ}\text{F}$, compressor is de-energized.
 - ii. If $T3 < 129.2^{\circ}\text{F}$, compressor is energized.
- ▶ Ambient temperature protection (T4)
 - i. If $40^{\circ}\text{F} \leq T4 < 125^{\circ}\text{F}$, unit can operate in cooling.
 - ii. If $5^{\circ}\text{F} \leq T4 < 86^{\circ}\text{F}$, unit can operate in heating.
 - iii. If $T4 < 5^{\circ}\text{F}$, heat pump will provide 24V control to indoor unit energizing electric heat (if installed).



See BOVB 18 Product Specification for extended performance data.

- ▶ Discharge Temperature (DT) protection (T5)
 - i. If $DT > 239^{\circ}\text{F}$ during cooling mode, the compressor will stop.
 - ii. If $DT < 194^{\circ}\text{F}$ during cooling mode, the compressor will restart.
 - iii. If $DT > 221^{\circ}\text{F}$ during heating mode, the compressor will stop.
 - iv. If $DT < 167^{\circ}\text{F}$ during heating mode, the compressor will restart.
- ▶ High Pressure (HP) protection (mechanical open/close pressure switch)
 - i. High Pressure Switch opens at $P > 580$ PSIG, the compressor and outdoor fan stop.
 - ii. High Pressure Switch closes at $P < 435$ PSIG, the compressor and outdoor fan restart.
- ▶ Low Pressure (LP) protection
 - i. If Low Pressure < 43.5 PSI for 5 minutes during cooling mode, the compressor and outdoor fan will stop. The system will attempt to run again after 6 minutes.
 - ii. If condensing temp. $Tc < \text{outdoor ambient temp. } T4$ during heating mode, the compressor and outdoor fan will stop.
- ▶ Module (inverter) protection (TF)
 - i. If $TF > 176^{\circ}\text{F}$, the compressor and outdoor fan will stop.
 - ii. If $TF < 154^{\circ}\text{F}$, the compressor and outdoor fan will restart.

15.8 Fault Code Table

Code	Fault Description (Sensor)
C3	The coil sensor is seated fault in cooling (T3)
E4	Temperature sensor fault (T3, T4, T5)
E5	High/low voltage protection
E6	DC fan motor fault (only for 48/60K model)
E7	Compressor discharge sensor is seated fault (T5)
E9	EEPROM fault
H0	Communication fault in main control chip
H5*	5 times (P2) protection in 100 minutes, system lockout
H8	Pressure transducer fault (PT)
P0	High module radiator temperature protection (TF)
P1	High pressure switch protection (HPS)
P2	Low pressure protection in cooling or heating (PT)
P3	Compressor over current protection
P4	High compressor discharge temperature protection (T5)
P5	Condensor coil temperature protection in cooling (T3)
P8	DC fan motor hurricane/typhoon protection
PH	Low discharge superheat protection
F1	High pressure switch (HPS) fault
L0-L9	The IPM module protection
AtL	Ambient Temperature Limited

System Protection Status Codes**

┆	Forced operation mode
L	Running indication under T3 limited condition
d	Running indication under T5 limited condition
P	Running indication under compressor ratio limited condition
F	Running indication under TF limited condition
C	Running indication under current limited condition
U	Running indication under low voltage limited condition
A	Running indication under return oil mode
dF	Running indication under defrost mode

Table 13

* Fault requires hard restart

** If the first digit shown on the control board LED is one of the following protection codes (followed by two numerical digits which show the current compressor frequency in Hz), the unit will continue to run but in a limited condition. The only exception is when the system is in defrost mode, which only displays "dF" (without any numerical digits following).

15.9 Parameter Point Check Table

- ▶ To display system parameters, press the “Check” button to index through the series of parameters available. The first time you press the “Check” button, it will display the sequence, and after 1 second it will display the value of the parameter. If you press the “Check” button again, it will display the next sequence. Refer to Figure 44 and 45 for check button location on the control board.
- ▶ Normal Status, last two digits will display under the following conditions
 - i. Unit not operating (Standby Mode); “outdoor ambient temperature”.
 - ii. Unit operating; displays “compressor operating frequency”.
- ▶ After 20 seconds on same parameter, the display will revert back to normal status.
- ▶ If a system protection is active, first digit will display “status code”.

No.	Point check content	Example	Remark
0	Outdoor unit capacity	H3	H3=Heat Pump 3 ton
1	Outdoor unit mode	2	0 standby, 2 cooling, 3 heating
2	Outdoor unit set compressor speed (Hz)	66	
3	T3 (outdoor coil temp.) (°F)		
4	T4 (outdoor ambient temp.) (°F)		
5	T5 (compressor discharge temp.) (°F)		
6	Reserve	00	
7	Reserve	00	
8	Tf (module temp.) (°F)		
9	Pe (evaporating pressure) (PSI)		Suction Pressure (low pressure)
10	Pc (condensing pressure) (PSI)		Head Pressure (high pressure)
11	Tes target of the evaporating temp. (only use for cooling mode) (°F)		
12	Te (evaporating temp.) (°F)		
13	Tcs target of the condensing temp. (only use for heating mode) (°F)		
14	Tc (condensing temp.) (°F)		
15	Target of the compressor discharge superheat (only use for heating mode) (°F)		
16	Compressor discharge superheat (°F)		
17	Openings of EEV		
18	Fan speed		
19	Compressor current (A)		
20	Power AC voltage Input (V)		
21	Compressor input dc voltage (V)		
22	Continuous running time of the compressor (min)		
23	Last fault code	00	see Table 13
24	Software version	01	
25	Remark “--”	--	--

Table 14

15.10 Control Board Overviews

Main Control Board for 24/36 ODU Model

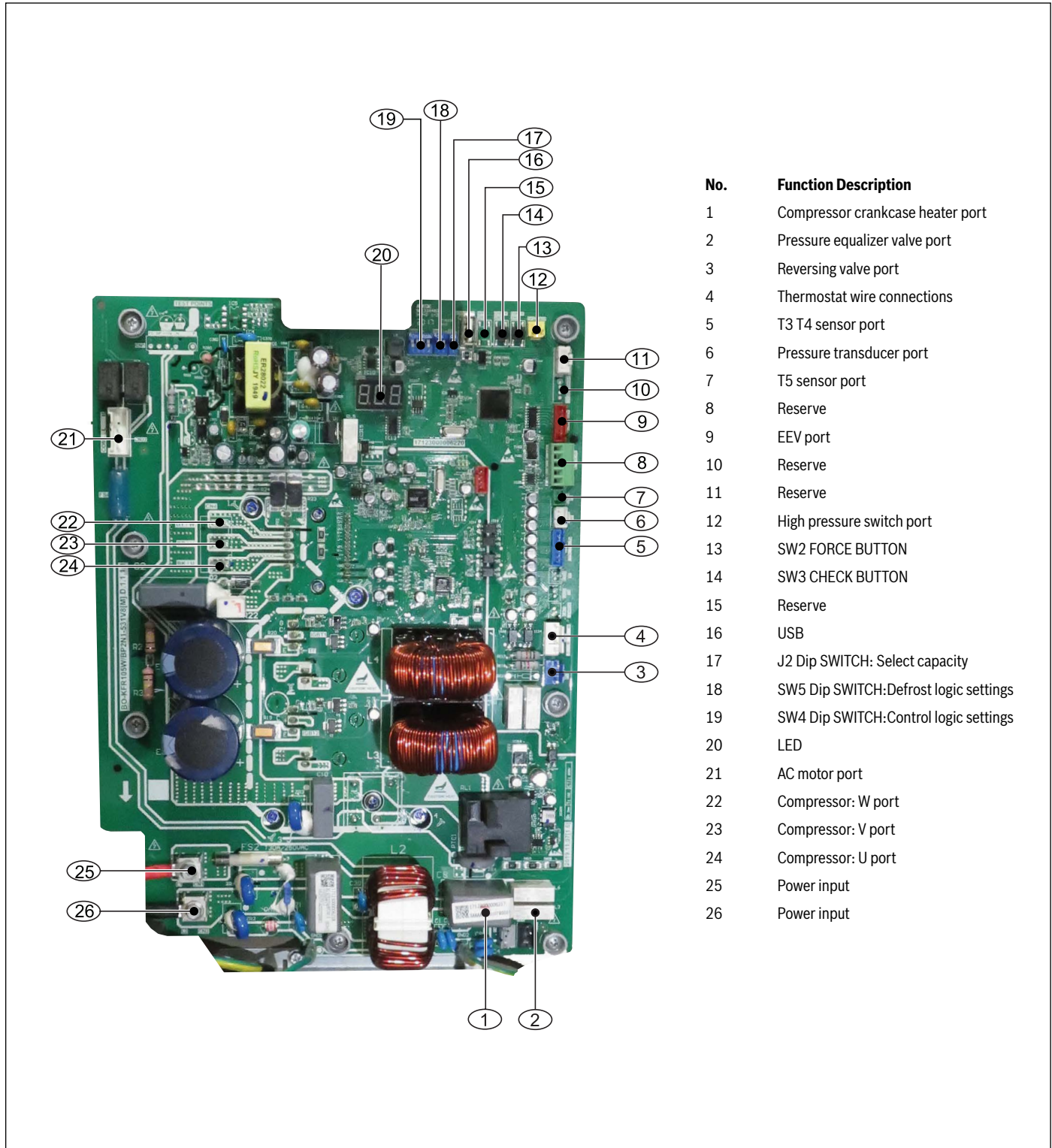

No.	Function Description
1	Compressor crankcase heater port
2	Pressure equalizer valve port
3	Reversing valve port
4	Thermostat wire connections
5	T3 T4 sensor port
6	Pressure transducer port
7	T5 sensor port
8	Reserve
9	EEV port
10	Reserve
11	Reserve
12	High pressure switch port
13	SW2 FORCE BUTTON
14	SW3 CHECK BUTTON
15	Reserve
16	USB
17	J2 Dip SWITCH: Select capacity
18	SW5 Dip SWITCH:Defrost logic settings
19	SW4 Dip SWITCH:Control logic settings
20	LED
21	AC motor port
22	Compressor: W port
23	Compressor: V port
24	Compressor: U port
25	Power input
26	Power input

Figure 45

Main Control Board for 48/60 ODU Model

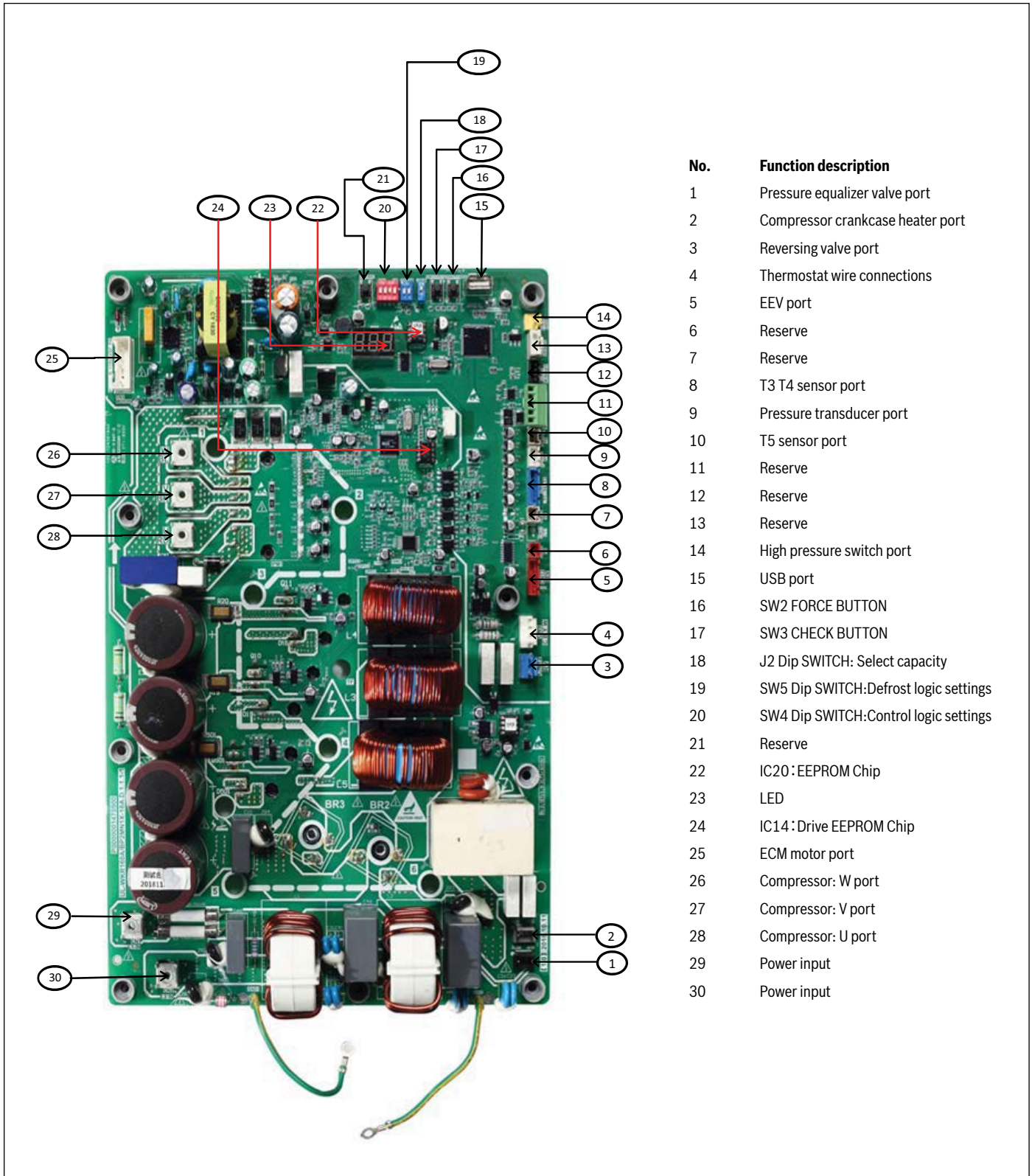

No.	Function description
1	Pressure equalizer valve port
2	Compressor crankcase heater port
3	Reversing valve port
4	Thermostat wire connections
5	EEV port
6	Reserve
7	Reserve
8	T3 T4 sensor port
9	Pressure transducer port
10	T5 sensor port
11	Reserve
12	Reserve
13	Reserve
14	High pressure switch port
15	USB port
16	SW2 FORCE BUTTON
17	SW3 CHECK BUTTON
18	J2 Dip SWITCH: Select capacity
19	SW5 Dip SWITCH:Defrost logic settings
20	SW4 Dip SWITCH:Control logic settings
21	Reserve
22	IC20 : EEPROM Chip
23	LED
24	IC14 : Drive EEPROM Chip
25	ECM motor port
26	Compressor: W port
27	Compressor: V port
28	Compressor: U port
29	Power input
30	Power input

Figure 46

15.11 Error Code Troubleshooting

Error Code	Description (Sensor)
P1	High pressure switch (HPS) protection
P5	Condenser coil temperature (T3) protection in cooling
P3	Compressor over current protection

Table 15

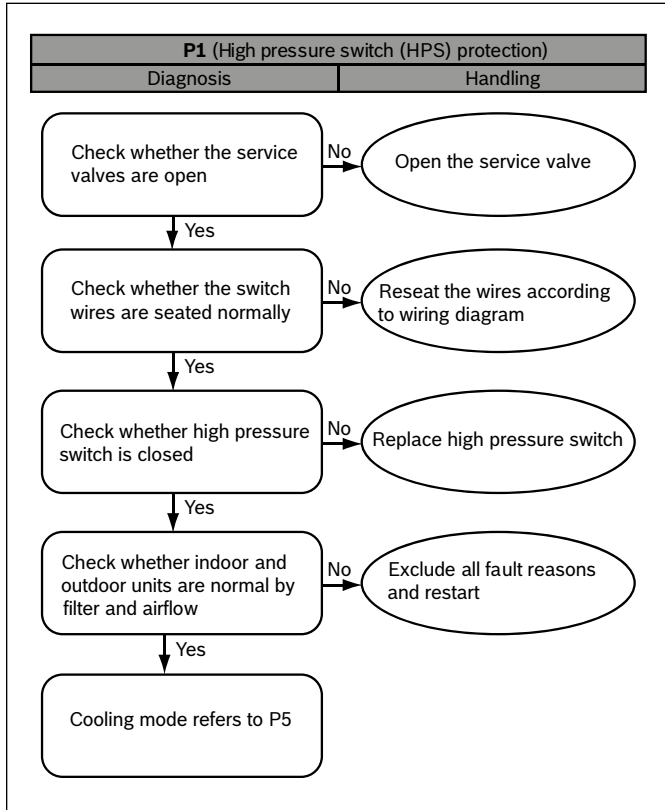

Figure 47

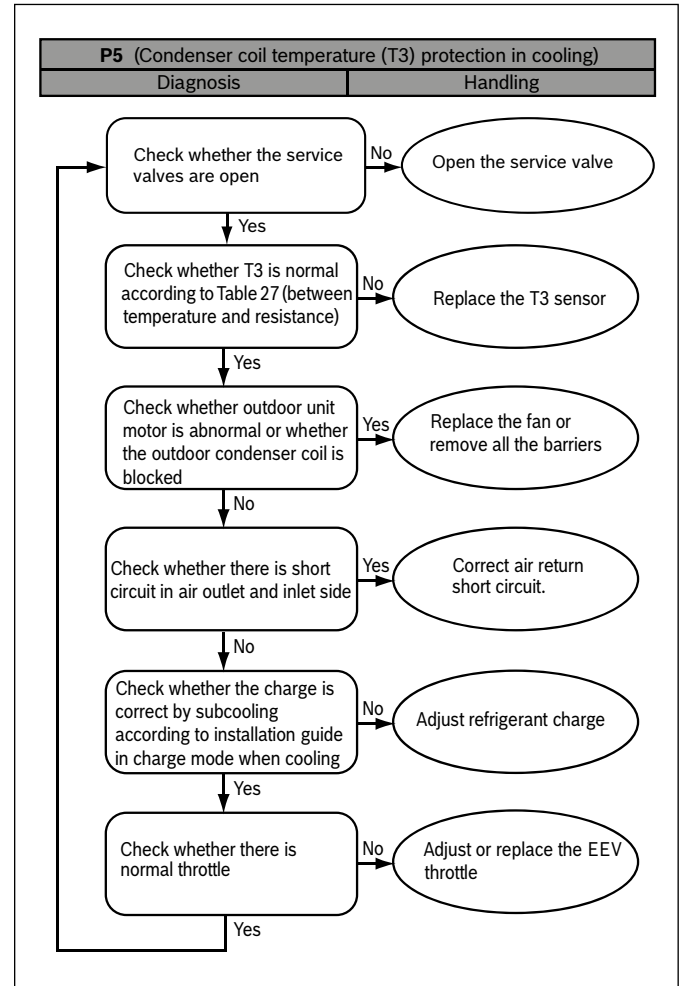

Figure 48

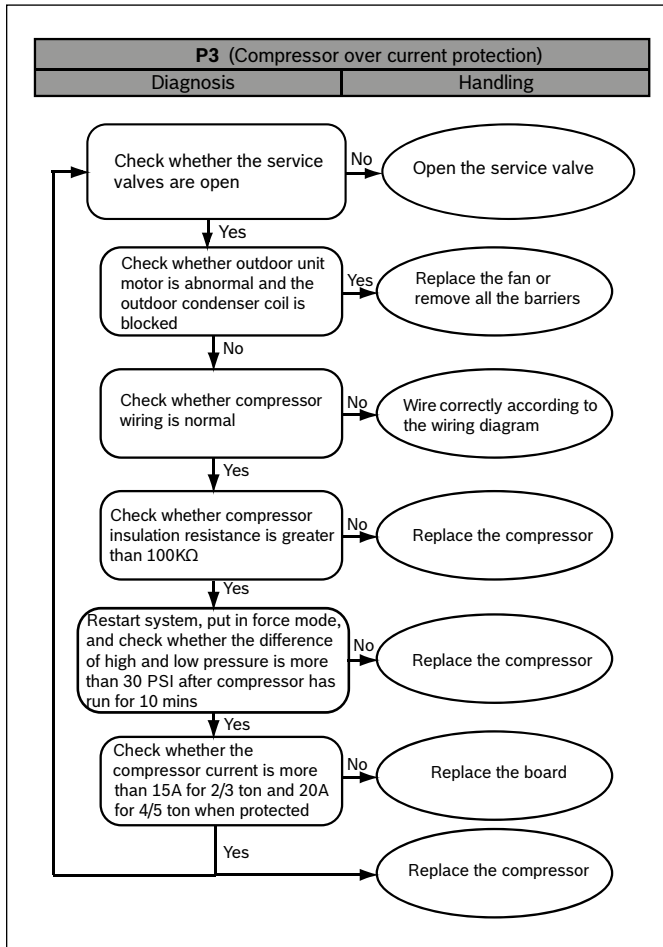

Figure 49

Error Code	Description
P0	High module radiator temperature (TF) protection

Table 16

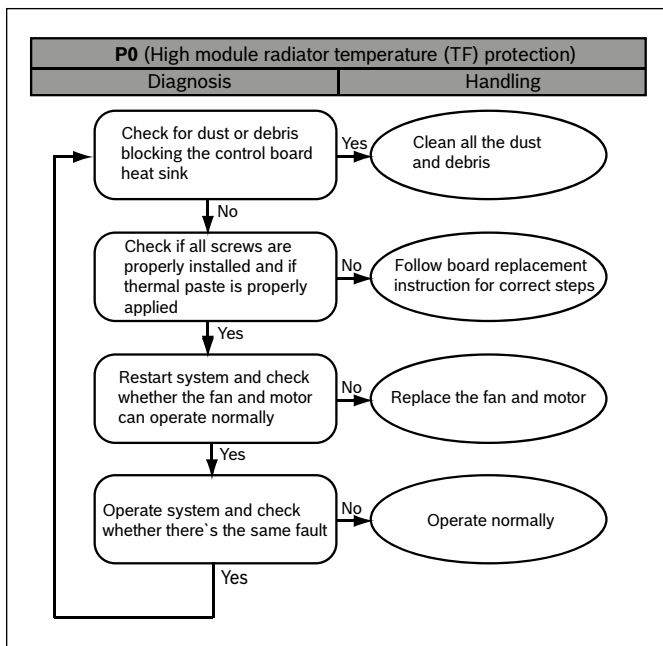

Figure 50

Error Code	Description
P2	Low pressure (PT) Protection in cooling and heating
H5	System lockup, 5 times (P2) protection in 100 minutes
P4	High compressor discharge temperature(T5) protection

Table 17

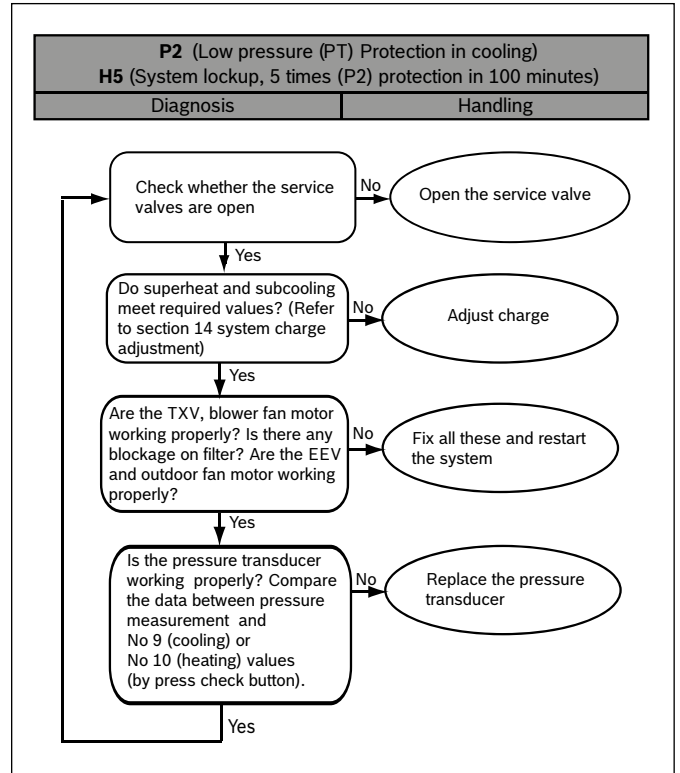

Figure 51

Error Code	Description
E4	Temperature sensor fault (T3, T4, T5)
H8	Pressure transducer (PT) fault
F1	High pressure switch (HPS) fault

Table 18

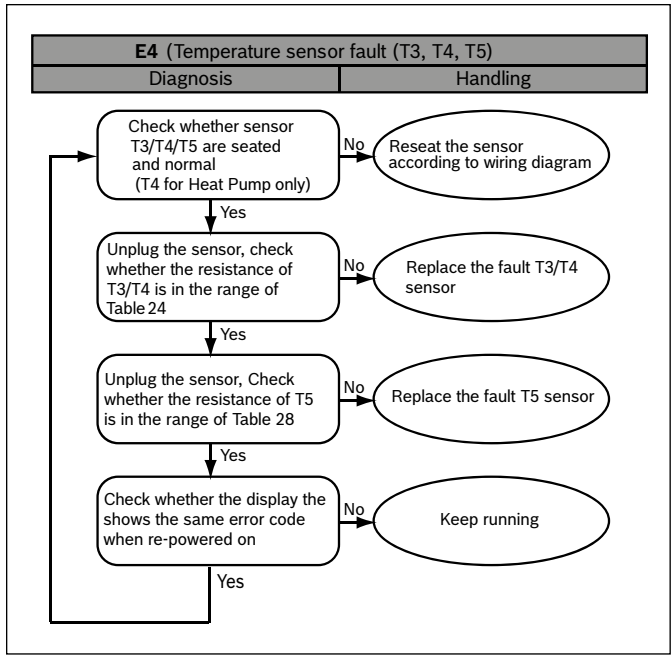

Figure 53

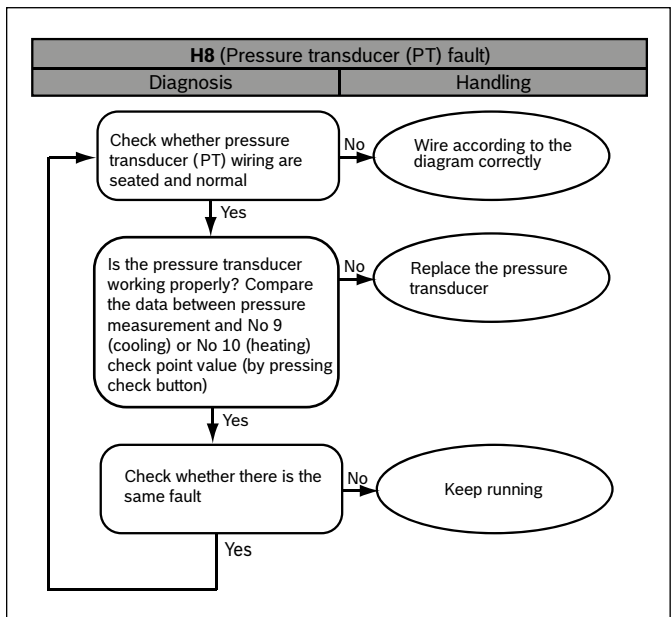

Figure 54

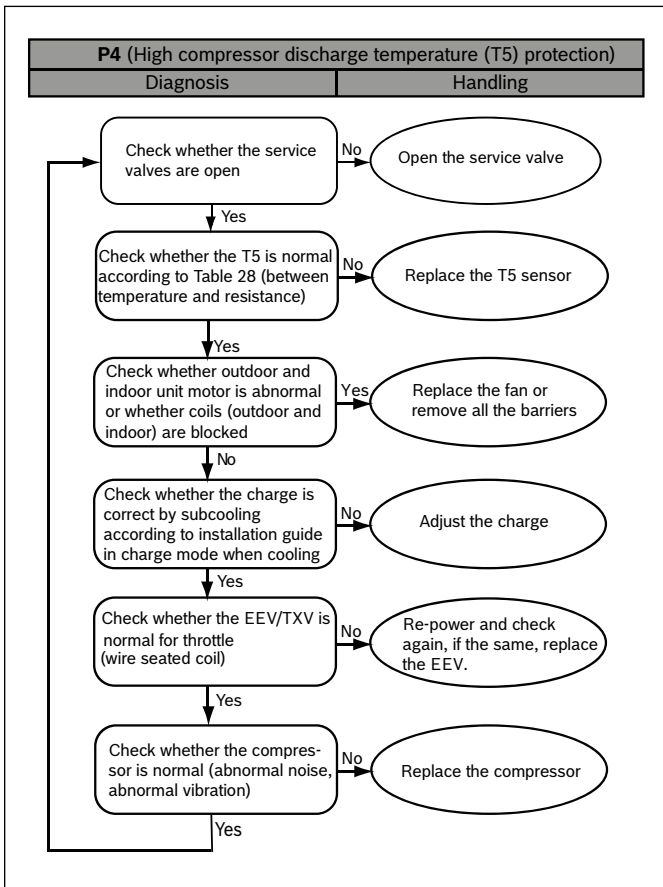

Figure 52

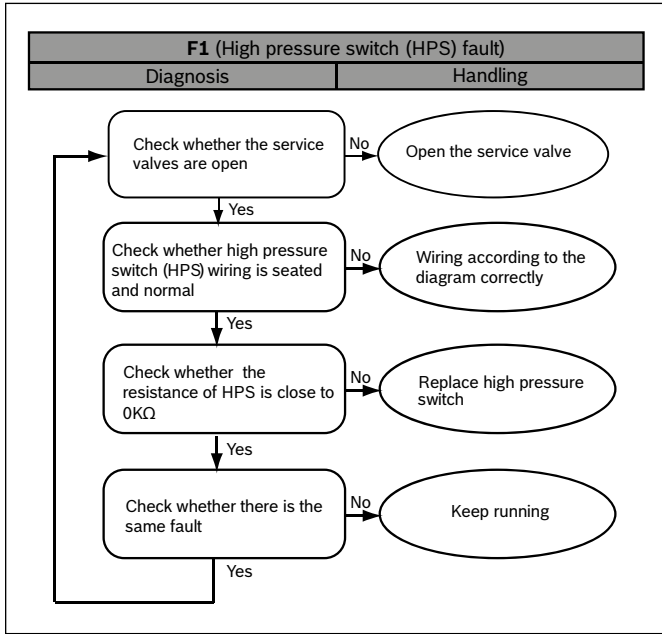

Figure 55

Error Code	Description
C3	Condenser coil sensor (T3) is seated fault in cooling
E7	Compressor discharge sensor (T5) is seated fault

Table 19

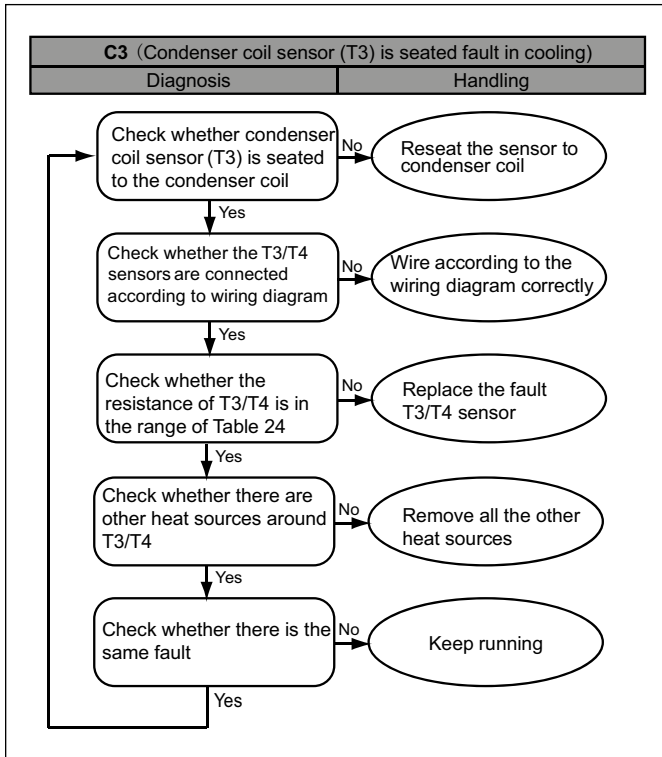

Figure 56

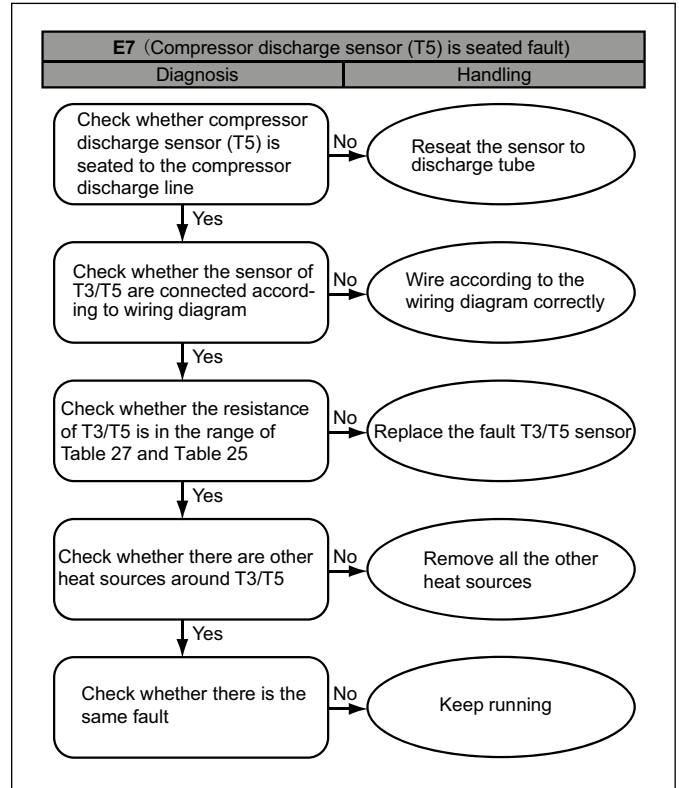

Figure 57

Error Code	Description
E6	DC fan motor fault (for 48K/60K model)

Table 20

If the E6 error code appears occasionally, no action is necessary. The system will restart automatically after 6 minutes.

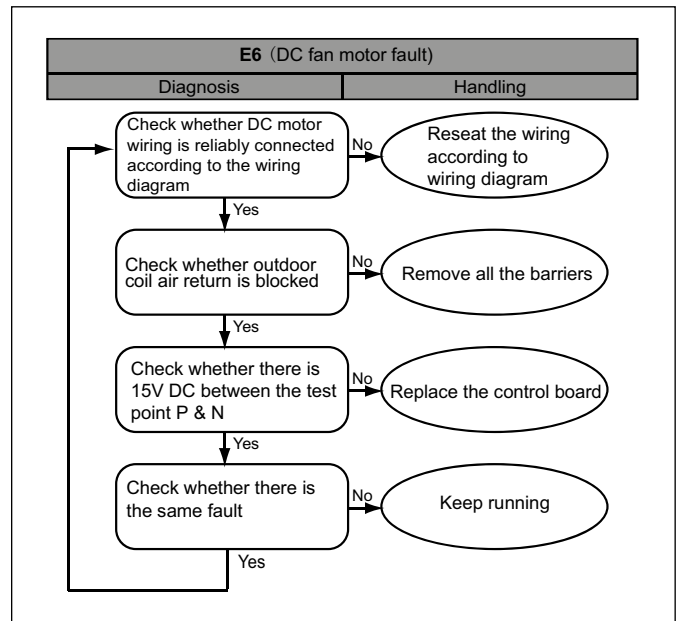

Figure 58

Error Code	Description
E9	EEPROM fault
H0	Communication fault in main control chip
E5	High/low voltage protection

Table 21

If error codes E9/H0/E5 appear occasionally and after the system restarts and runs normally after the power supply is re-established, no action is necessary. Otherwise the system must be checked.

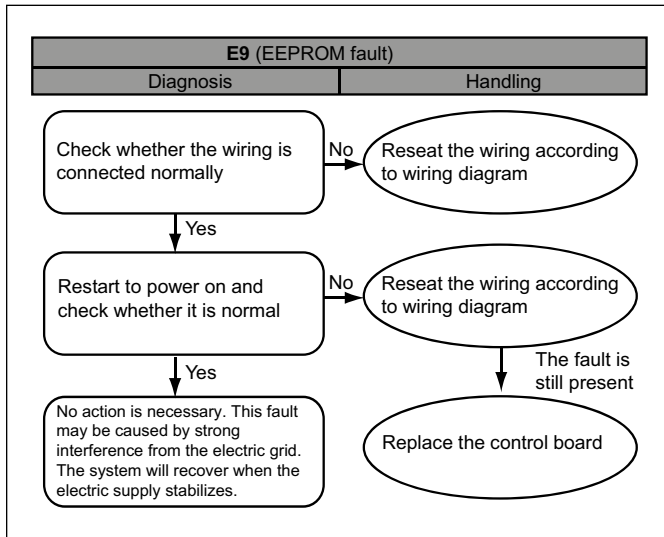

Figure 59

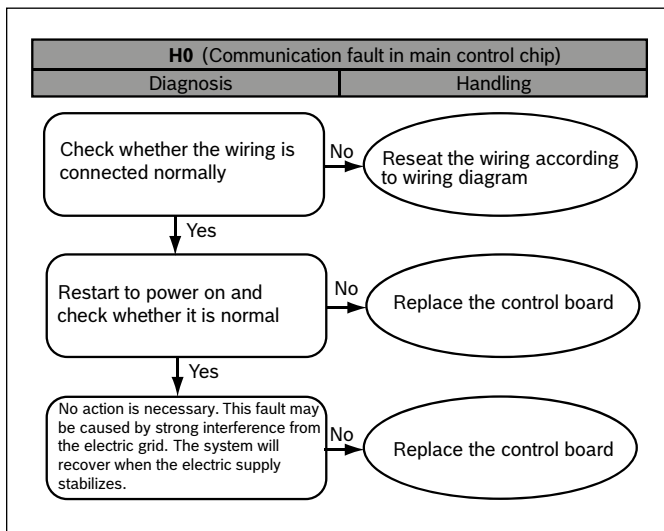

Figure 60

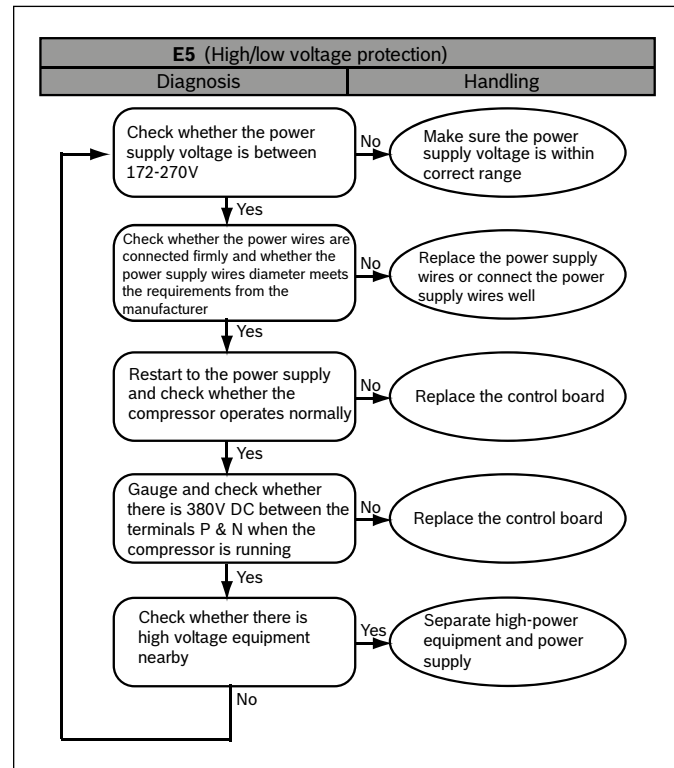

Figure 61

Error Code	Description
L0-L9	IPM module protection

Table 22

When L0-L9 appears occasionally, you don't need to do anything, the system will restart automatically after 6 minutes. Please follow below step if L0-L9 consistently appears.

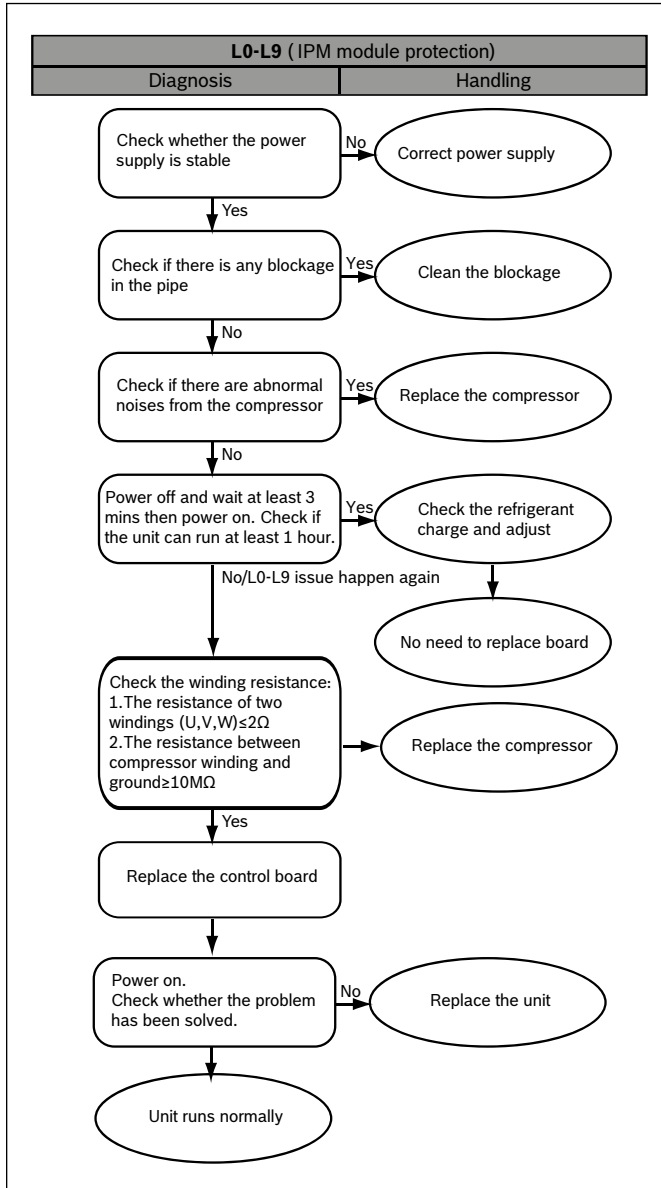

Figure 62

Error Code	Description
AtL	Ambient Temperature Limited

Table 23



When the ambient temperature returns to within the operating range, the system will recover automatically.

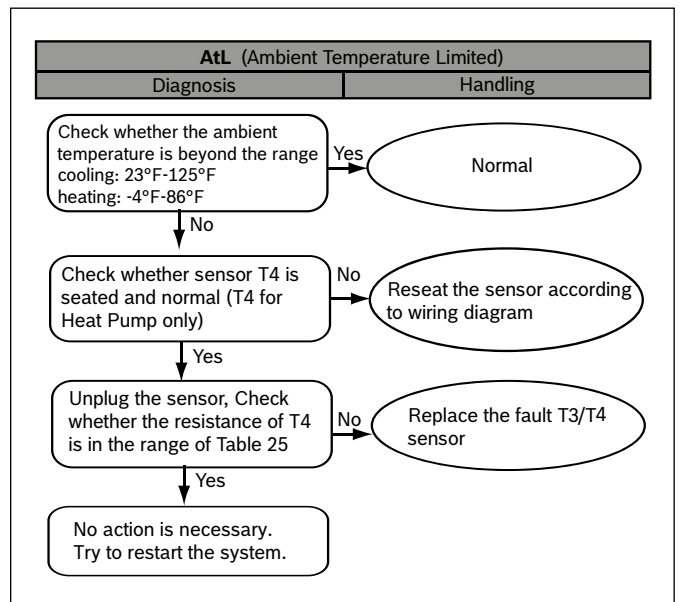

Figure 63

Error Code	Description
	No display on control board

Table 24

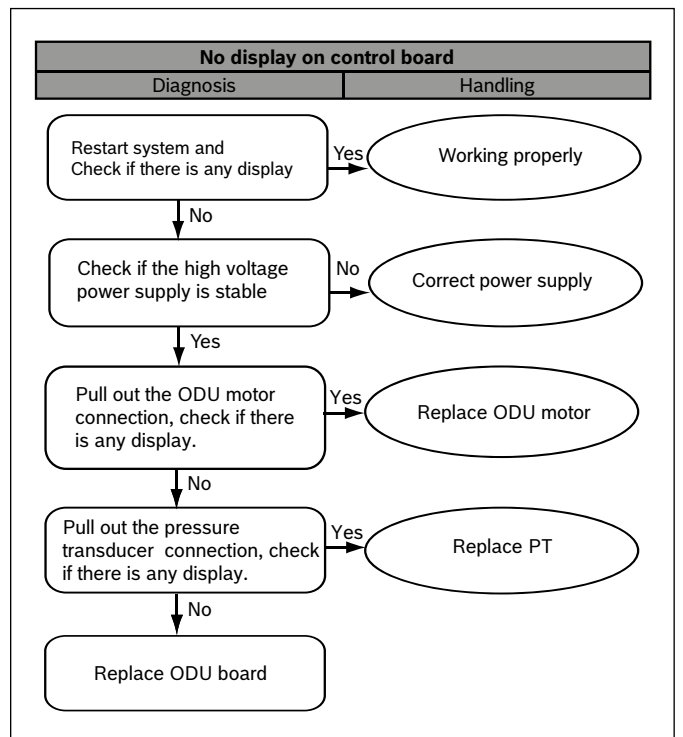

Figure 64

15.12 Temperature and Resistance Relationship Tables (for Sensors)

TEMP F	TEMP C	RESISTANCE kΩ	VOLTS DC	TEMP F	TEMP C	RESISTANCE kΩ	VOLTS DC
-5	-20.6	107.732	4.65	90	32.2	7.225	2.36
0	-17.8	93.535	4.60	95	35.0	6.401	2.21
5	-15.0	79.521	4.54	100	37.8	5.683	2.07
10	-12.2	67.795	4.47	105	40.6	5.057	1.93
15	-9.4	57.948	4.39	110	43.3	4.509	1.79
20	-6.7	49.652	4.30	115	46.1	4.028	1.67
25	-3.9	42.645	4.21	120	48.9	3.606	1.55
30	-1.1	36.710	4.10	125	51.7	3.233	1.43
40	4.4	27.386	3.86	130	54.4	2.902	1.32
45	7.2	23.732	3.73	135	57.2	2.610	1.22
50	10.0	20.610	3.59	140	60.0	2.350	1.13
55	12.8	17.939	3.45	145	62.8	2.119	1.04
60	15.6	15.648	3.30	150	65.6	1.914	0.96
65	18.3	13.681	3.15	155	68.3	1.731	0.88
70	21.1	11.987	2.99	160	71.1	1.574	0.82
75	23.9	10.527	2.83	165	73.9	1.416	0.75
80	26.7	9.265	2.67	170	76.7	1.276	0.68
85	29.4	8.172	2.52				

Table 25 for T3, T4

15.13 Temperature and Resistance Relationship Tables (for T5)

TEMP F	TEMP C	RESISTANCE kΩ	VOLTS DC	TEMP F	TEMP C	RESISTANCE kΩ	VOLTS DC
-5	-20.6	600.134	4.93	140	60.0	13.643	3.14
0	-17.8	505.551	4.92	145	62.8	12.359	3.03
5	-15.0	427.463	4.91	150	65.6	11.214	2.91
10	-12.2	362.739	4.89	155	68.3	10.227	2.80
15	-9.4	308.891	4.87	160	71.1	9.308	2.68
20	-6.7	265.398	4.85	165	73.9	8.485	2.56
25	-3.9	227.481	4.83	170	76.7	7.746	2.45
30	-1.1	195.601	4.80	175	79.4	7.105	2.34
35	1.7	168.707	4.77	180	82.2	6.504	2.23
40	4.4	146.695	4.74	185	85.0	5.963	2.13
45	7.2	127.258	4.70	190	87.8	5.474	2.02
50	10.0	110.707	4.66	195	90.6	5.032	1.92
55	12.8	96.572	4.61	200	93.3	4.645	1.83
60	15.6	84.465	4.56	205	96.1	4.28	1.73
65	18.3	74.411	4.51	210	98.9	3.949	1.64
70	21.1	65.408	4.45	215	101.7	3.648	1.56
75	23.9	57.634	4.39	220	104.4	3.383	1.48
80	26.7	50.904	4.32	225	107.2	3.133	1.40
85	29.4	45.258	4.24	230	110	2.904	1.32
90	32.2	40.152	4.16	235	112.8	2.694	1.25
95	35.0	35.699	4.08	240	115.6	2.503	1.18
100	37.8	31.807	3.99	245	118.3	2.334	1.12
105	40.6	28.398	3.89	250	121.1	2.172	1.06
110	43.3	25.506	3.80	255	123.9	2.024	1.00
115	46.1	22.861	3.70	260	126.7	1.888	0.95
120	48.9	20.529	3.59	265	129.4	1.767	0.90
125	51.7	18.47	3.48	270	132.2	1.651	0.85
130	54.4	16.708	3.37	275	135.0	1.544	0.80
135	57.2	15.085	3.26	280	137.8	1.446	0.76

Table 26 for T5

TEMP F	TEMP C	RESISTANCE kΩ	VOLTS DC	TEMP F	TEMP C	RESISTANCE kΩ	VOLTS DC
-5	-20.6	107.732	4.65	90	32.2	7.225	2.36
0	-17.8	93.535	4.60	95	35.0	6.401	2.21
5	-15.0	79.521	4.54	100	37.8	5.683	2.07
10	-12.2	67.795	4.47	105	40.6	5.057	1.93
15	-9.4	57.948	4.39	110	43.3	4.509	1.79
20	-6.7	49.652	4.30	115	46.1	4.028	1.67
25	-3.9	42.645	4.21	120	48.9	3.606	1.55
30	-1.1	36.710	4.10	125	51.7	3.233	1.43
40	4.4	27.386	3.86	130	54.4	2.902	1.32
45	7.2	23.732	3.73	135	57.2	2.610	1.22
50	10.0	20.610	3.59	140	60.0	2.350	1.13
55	12.8	17.939	3.45	145	62.8	2.119	1.04
60	15.6	15.648	3.30	150	65.6	1.914	0.96
65	18.3	13.681	3.15	155	68.3	1.731	0.88
70	21.1	11.987	2.99	160	71.1	1.574	0.82
75	23.9	10.527	2.83	165	73.9	1.416	0.75
80	26.7	9.265	2.67	170	76.7	1.276	0.68
85	29.4	8.172	2.52				

Table 27

16 Wiring Diagrams

16.1 BOVB36-18 (3 ton)

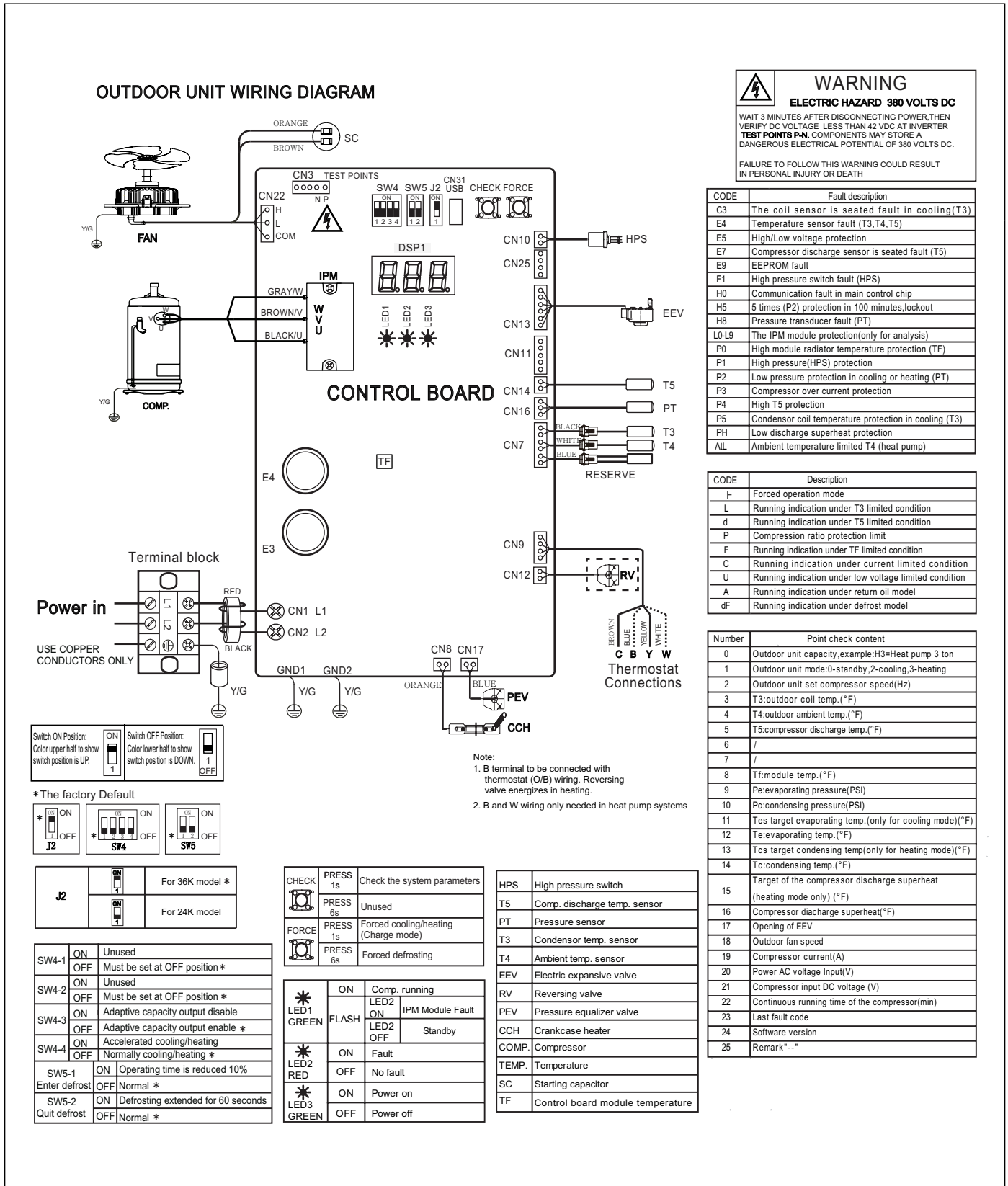

Figure 65

16.2 BOVB60-18 (5 ton)

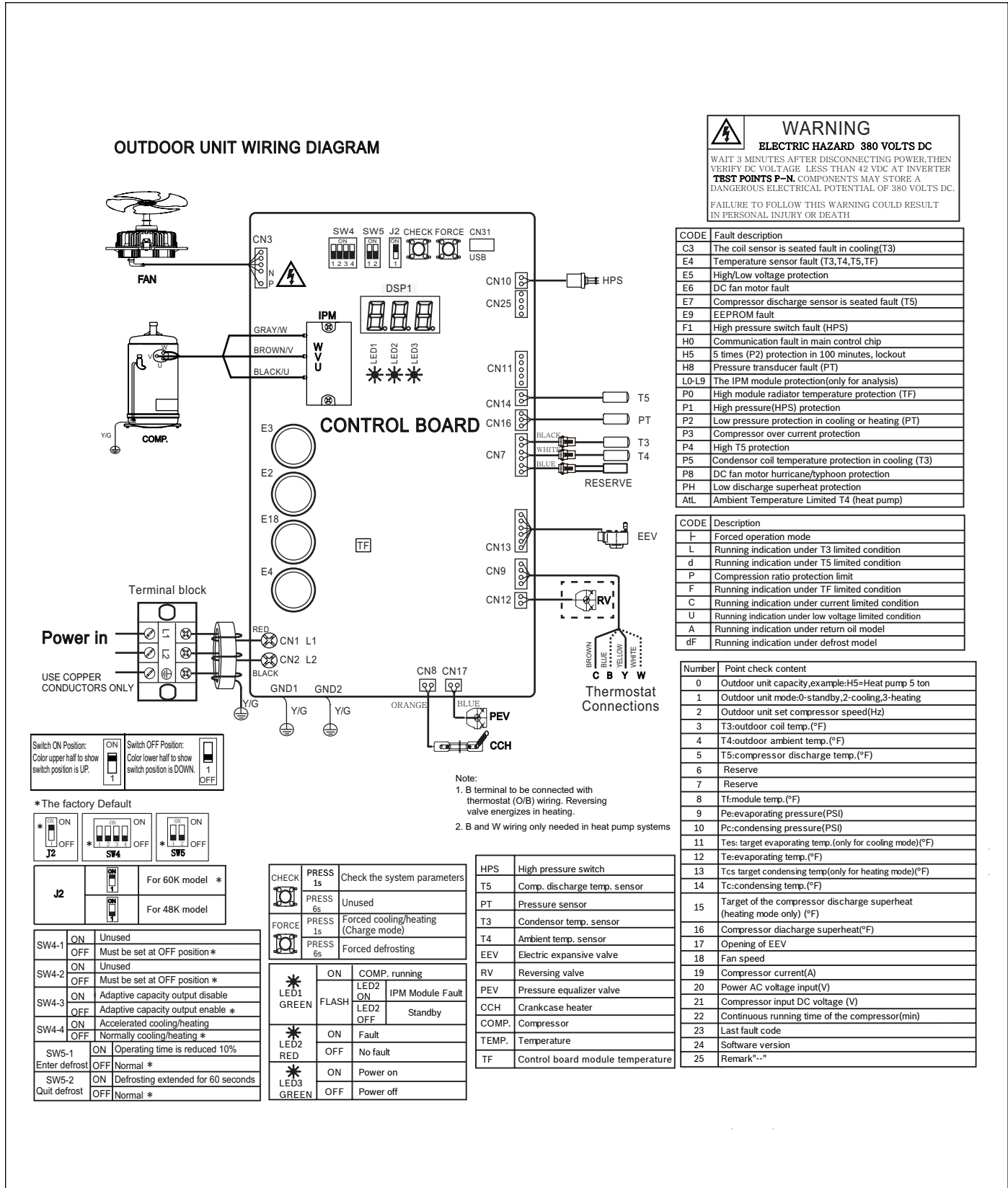

Figure 66

17 Care and Maintenance

17.1 Cleaning Precautions



WARNING:

- ▶ Any maintenance and cleaning of outdoor unit must be performed by qualified service personnel only.
- ▶ Any unit repairs must be performed by qualified service personnel only.



CAUTION: ELECTRIC SHOCK

- ▶ Always turn off your heat pump and disconnect the power supply before cleaning or maintenance.

NOTICE:

- ▶ Do not use chemicals or chemically treated cloths to clean the unit .
- ▶ Do not use benzene, paint thinner, polishing powder or other solvents to clean the unit.



CAUTION:

- ▶ When removing filter, do not touch metal parts in the unit. The sharp metal edges can cut you.

17.2 Maintenance - Pre-Season Inspection

At the beginning of each heating or cooling season, do the following:

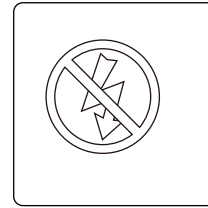

Turn off the unit and disconnect the power

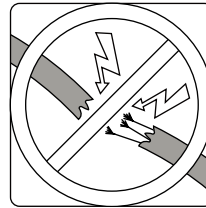

Check for damaged wires



Check for leaks



Make sure nothing is blocking all air inlets and outlets

Figure 67

Notes:

United States and Canada

Bosch Thermotechnology Corp.
65 Grove St.
Watertown, MA 02472

Tel: 866-642-3198
Fax: 954-776-5529
www.bosch-homecomfort.us