



Installation and Operation  
Instructions for

## **THE FT SERIES**

Wall-Mounted, Modulating  
Gas, Condensing, Combination Boiler

Model FTCW

140,000 BTU/hr

199,000 BTU/hr



- Natural Gas (NG) - Factory Configuration
- Propane Gas (LP) - Field-Convertible

**FOR YOUR SAFETY:** This product must be installed and serviced by a professional service technician, qualified in hot water boiler and heater installation and maintenance. Improper installation and/or operation could create carbon monoxide gas in flue gases which could cause serious injury, property damage, or death. Improper installation and/or operation will void the warranty.

### **⚠ WARNING**

If the information in this manual is not followed exactly, a fire or explosion may result causing property damage, personal injury or loss of life.

Do not store or use gasoline or other flammable vapors and liquids in the vicinity of this or any other appliance.

#### **WHAT TO DO IF YOU SMELL GAS**

- Do not try to light any appliance.
- Do not touch any electrical switch; do not use any phone in your building.
- Immediately call your gas supplier from a nearby phone. Follow the gas supplier's instructions.
- If you cannot reach your gas supplier, call the fire department.

Installation and service must be performed by a qualified installer, service agency, or gas supplier.

### **⚠ AVERTISSEMENT**

Assurez-vous de bien suivre les instructions données dans cette notice pour réduire au minimum le risque d'incendie ou d'explosion ou pour éviter tout dommage matériel, toute blessure ou la mort.

Ne pas entreposer ni utiliser d'essence ou ni d'autres vapeurs ou liquides inflammables dans le à proximité de cet appareil ou de tout autre appareil.

#### **QUE FAIRE SI VOUS SENTEZ UNE ODEUR DE GAZ:**

- Ne pas tenter d'allumer d'appareils.
- Ne touchez à aucun interrupteur. Ne pas vous servir des téléphones dans le bâtiment où vous vous trouvez.
- Appelez immédiatement votre fournisseur de gaz depuis un voisin. Suivez les instructions du fournisseur.
- Si vous ne pouvez rejoindre le fournisseur de gaz, appelez le service des incendies.

L'installation et l'entretien doivent être assurés par un installateur ou un service d'entretien qualifié ou par le fournisseur de gaz.

# TABLE OF CONTENTS

## SECTION 1 Product Accessories

1.1	Introduction	3
1.2	Included with the Unit	3

## SECTION 2 Product Characteristics

2.1	Model Nomenclature (model number)	5
2.2	Specifications	6
2.3	Dimensions	8
2.4	Names of Components	10
2.5	Product Flow Paths and Characteristics	12
2.5.1	Central Heating flow.	12
2.6	Product Flow Paths and Characteristics	13
2.6.1	Domestic Hot Water flow.	13

## SECTION 3 Safety Regulations

3.1	Safety Symbols	14
3.2	Safety Precautions and Proper Use	16

## SECTION 4 Installation

4.1	Location and Clearances	18
4.2	Wall Mount Bracket	19
4.3	Combustion Air	20
4.3.1	Combustion Air from Room	20
4.3.2	Ducted Combustion Air	20
4.4	Venting (Exhaust)	22
4.5	General Location Guideline	23
4.6	Locations for Vent Pipe Terminator	24
4.6.1	Direct Venting Clearances	24
4.6.2	Venting Requirements in the Commonwealth of Massachusetts	25
4.7	Common Vent Test	26
4.8	Air Supply and Vent Connections	27
4.8.1	Vent / Air Pipe Lengths	27
4.8.2	Indoor Combustion Air	28
4.9	Vent / Air Pipe Termination	28
4.10	Gas Supply and Piping	31
4.11	Gas Supply Pressure	34
4.12	Adjusting Combustion	35
4.13	High Altitude Installations	36
4.14	Natural Gas to Propane Conversion	37
4.15	Plumbing Guidelines	41
4.15.1	External Plumbing and Water Connection Guidelines	41
4.15.2	Applicable Backflow Preventer	41
4.15.3	Diaphragm type Expansion tank	41
4.15.4	Zoning with zone valves	42

4.15.5	Zoning with circulation pumps	43
4.16	Pressure Relief Valve	44
4.17	Disposal of Condensate	45
4.18	DHW Flow Restrictors	46
4.19	Electrical Wiring Connections	47
4.20	DIP Switches	48
4.21	Control Board, Electrical Diagram	49
4.22	Ladder Diagram	50
4.23	Electrical Connections	51

## SECTION 5 Control Display and Operation

5.1	Control Dial and Buttons	53
5.2	LCD Overview	54
5.3	Operating Mode	55
5.4	Status Display Mode	56
5.5	DHW Set Point Change Mode	57
5.6	CH Set Point Change Mode	58
5.7	Storage Mode	58
5.8	Installer Parameters	59
5.9	Outdoor Reset Adjustment	61
5.10	External Set Point Temperature Control	61
5.11	Error Mode	62

## SECTION 6 Error Codes

6.1	Error Code Tables	63
6.2	Fault Tree Analysis	66

## SECTION 7 Trouble Shooting

7.1	Diagnostics	68
7.2	Suggested Corrective Actions	69

## SECTION 8 Maintenance

8.1	Annual startup & general maintenance	71
8.2	Flushing the Combination Boiler	73
8.3	Draining and Cleaning	74
8.4	Freeze Protection	74

## SECTION 9 Installation Check

9.1	Quick View	75
9.2	Final Check Lists	76

## SECTION 10 Parts List and Illustrations

10.1	FT 140	78
10.2	FT 199	85

## SECTION 1 Product Accessories


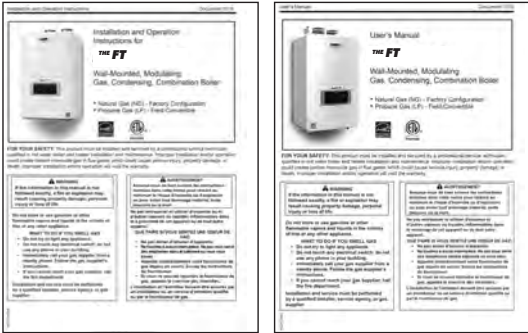
### 1.1 Introduction

This manual provides information necessary for the installation, operation, and maintenance of the **FT Series Wall Mounted, Combination Boiler**. All application and installation procedures must be read and reviewed completely before proceeding with the installation. Consult the factory, or your local factory representative, with any problems or questions regarding this equipment. Experience has shown that most operating problems are caused by improper installation.

All installations must be made in accordance with  
 1) American National Standard Z223.1/NFPA54-Latest Edition “National Fuel Gas Code” or  
 2) CSA B149.1 “Natural Gas and Propane Installation Code” and with the requirement of the local utility or other authorities having jurisdiction. Such applicable requirements take precedence over the general instructions contained herein.

All electrical wiring is to be done in accordance with the local codes, or in the absence of local codes, with: 1) The National Electrical Code ANSI/NFPA No. 70-latest Edition, or 2) CSA STD. C22.1 “Canadian Electrical Code - Part 1”. This appliance must be electrically grounded in accordance with these codes.

### 1.2 Included with the Unit

Item	Description	Qty
Wall Mounted, Combination Boiler FTCW140 / 199		1
Installation Instructions and User's Manual		1

## 1.2 Included with the Unit (continued)

Items	Descriptions		Qty
Condensate Hose			1
Wall Mount Bracket			1
2 types of Wall Anchors			
Pressure Relief Valve (CH LINE 3/4" 30psi) Model: CASH ACME F-82			1
3" Mesh Screens			2
O-Ring and Gasket Kit			1
Outdoor Sensor with screws and anchors			1
	FTCW140	FTCW199	
4.5 GPM Flow Restrictor (dark blue)		N/A	1
Propane Conversion Orifice			1

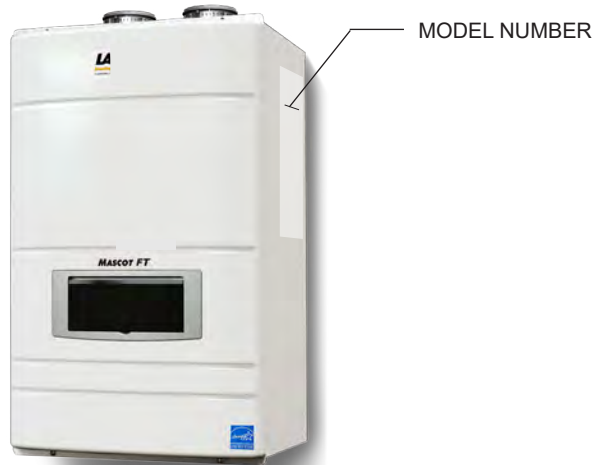
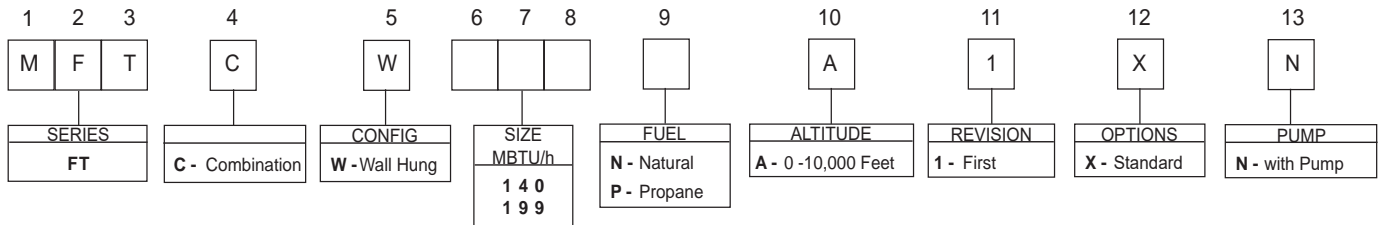
\* A 3.2 GPM Flow Restrictor (white) has been factory installed. See Section 4.17

Auto Fill Valve and Backflow Preventer Valves are NOT included (Field Supplied).

## SECTION 2 Product Characteristics

### 2.1 Model Nomenclature (model number)

The Model Nomenclature is shown on your Rating Plate and consists of a series of letters and numbers ( **Nomenclature** ) that further identifies the characteristics of your FT.



## 2.2 Specifications

Model Name		FTCW140	
Gas Input Rate	MAX	140,000 Btu/h	
	MIN	28,000 Btu/h	
Hot Water Capacity	35°F Rise	7.1 GPM	
	45°F Rise	5.5 GPM	
	77°F Rise	3.2 GPM	
Installation		Indoor / Wall hung type	
Flue System		Sealed Combustion Direct / Single Vent / Concentric Vent	
Vent Run		2"(50ft*) , 3"(100ft) Schedule 40 CPVC, PP, PVC	
Gas Supply Pressure	NG	3.5" WC to 10.5" WC	
	LP	8.0" WC to 13" WC	
Manifold Pressure	Gas type	NG	LP
	Vent size	2" or 3" VENT	2" or 3" VENT
	Max Fire	-0.216" WC	-0.216" WC
	Min Fire	0.002" WC	0.079" WC
Power Supply	Main Supply	120V 60Hz / 4A	
	Maximum Power Consumption	160W	
Ignition System		Direct Electronic Ignition / Automatic Flame Sensing	
Burner System		Single Orifice Premixed Fuel Modulation	
Gas Valve System		Combination modulating (Current proportional)	
Minimum Flow Rate		0.5 GPM	
Dimensions		W17.25" - H29.0" - D15.5"	
Shipping Weight		111 lbs (50 kg)	
Sub Heat Exchanger Water Capacity(DHW)		Under 1 Gallon	
Main Controller / Control Panel		NGTX-900CP / P-920C	
Domestic Hot Water Pressure, DHW		Min 15 ~ Max 150 PSI	
Central Heat Water Pressure, CH		Min 15 ~ Max 30 PSI	
Connection Sizes	Cold Water Inlet / Hot Water Outlet	3/4" NPT	
	(CH) Space Heating Supply/Return	1" NPT	
	Gas Inlet	3/4" NPT	
Materials	Casing	Cold Rolled Carbon Steel	
	Heat Exchanger	Primary Heat Exchanger : Stainless Steel Sub Heat Exchanger : Stainless Steel	
Safety Devices		Flame Rod, Overheat Cut Off Device, Gas Valve Operation Detector, Exhaust Temperature High Limit Switch, Water Temperature High Limit Switch	

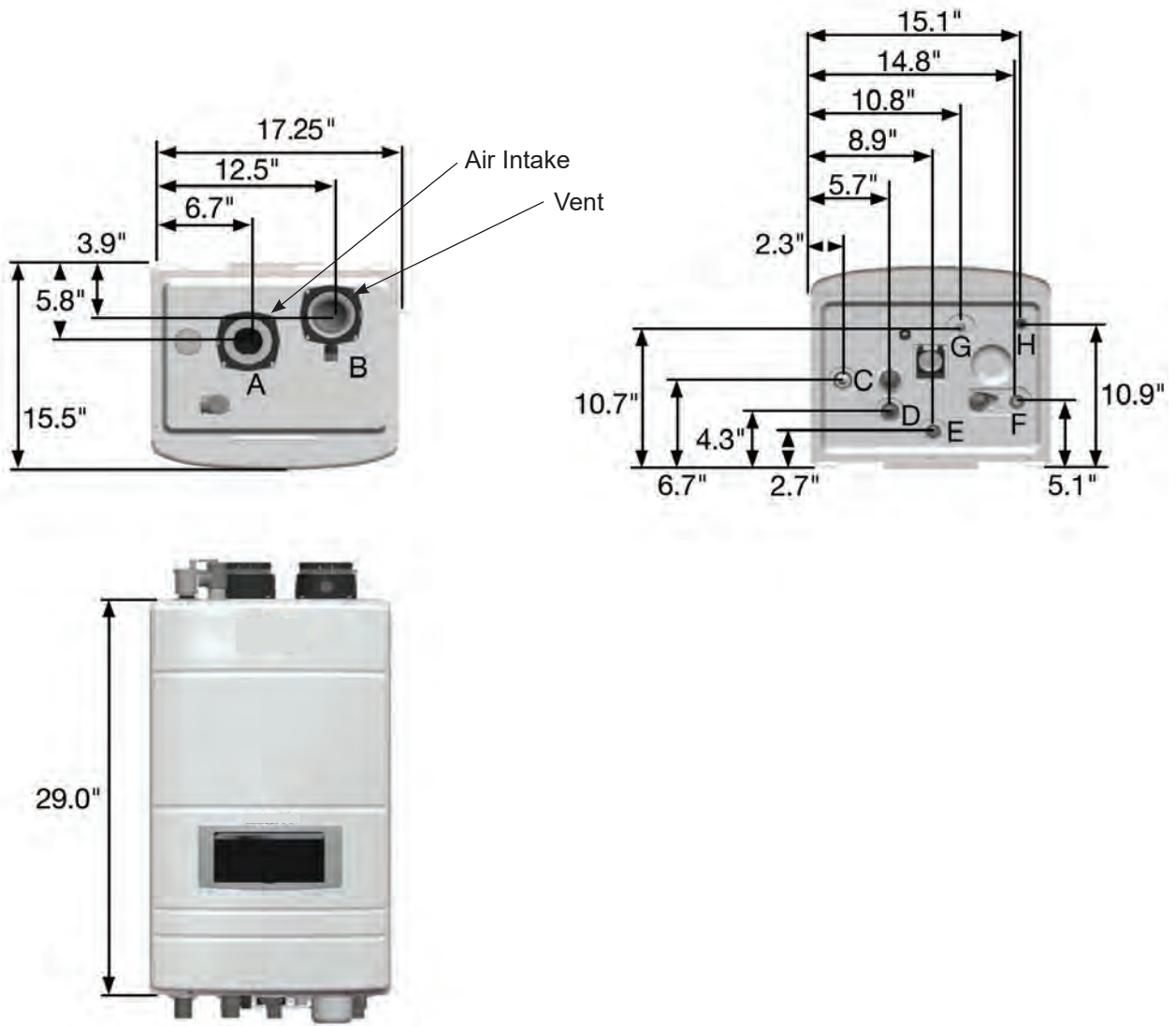
**\* Allowable 2" vent length for propane is 25'**

**2.2 Specifications (continued)**

Model Name		FTCW199	
Gas Input Rate	MAX	199,000 Btu/h	
	MIN	19,900 Btu/h	
Hot Water Capacity	35°F Rise	9.88 GPM	
	45°F Rise	7.7 GPM	
	77°F Rise	4.8 GPM	
Installation		Indoor / Wall hung type	
Flue System		Sealed Combustion Direct / Single Vent / Concentric Vent	
Vent Run		2"(50ft*) , 3"(100ft) Schedule 40 CPVC, PP, PVC	
Gas Supply Pressure	NG	3.5" WC to 10.5" WC	
	LP	8.0" WC to 13" WC	
Manifold Pressure	Gas type	NG	LP
	Vent size	2" VENT	3" VENT
	Max Fire	-0.314"WC	-0.173"WC
	Min Fire	-0.015"WC	-0.015"WC
Power Supply	Main Supply	120V 60Hz / 4A	
	Maximum Power Consumption	160W	
Ignition System		Direct Electronic Ignition / Automatic Flame Sensing	
Burner System		Single Orifice Premixed Fuel Modulation	
Gas Valve System		Combination modulating (Current proportional)	
Minimum Flow Rate		0.5 GPM	
Dimensions		W19.6" - H32.0" - D16.3"	
Shipping Weight		130 lbs (59 kg)	
Sub Heat Exchanger Water Capacity(DHW)		Under 1 Gallon	
Main Controller / Control Panel		NGTX-900CP / P-920C	
Domestic Hot Water Pressure, DHW		Min 15 ~ Max 150 PSI	
Central Heat Water Pressure, CH		Min 15 ~ Max 30 PSI	
Connection Sizes	Cold Water Inlet / Hot Water Outlet	3/4" NPT	
	(CH) Space Heating Supply/Return	1" NPT	
	Gas Inlet	3/4" NPT	
Materials	Casing	Cold Rolled Carbon Steel	
	Heat Exchanger	Primary Heat Exchanger : Stainless Steel Sub Heat Exchanger : Stainless Steel	
Safety Devices		Flame Rod, Overheat Cut Off Device, Gas Valve Operation Detector, Exhaust Temperature High Limit Switch, Water Temperature High Limit Switch	

**\* Allowable 2" vent length for propane is 25'**

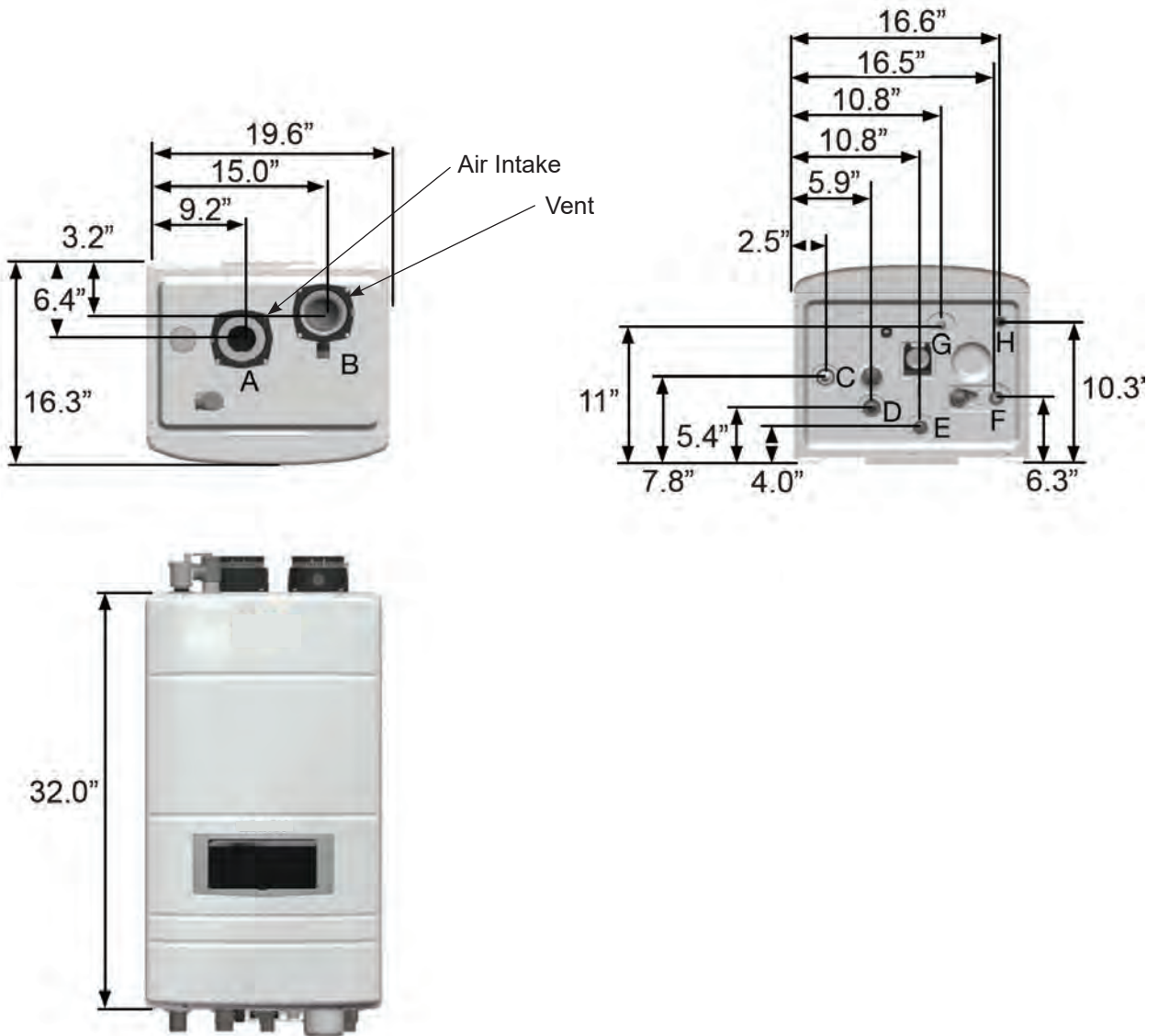
2.3 Dimensions FTCW140



	Description	Diameter
A	Air Intake collar	3"
B	Vent Pipe Collar	3"
C	'CH' Supply	1" NPT
D	'CH' Return	1" NPT
E	'DHW' Outlet	3/4" NPT
F	'DHW' Inlet	3/4" NPT
G	Gas Inlet	3/4" NPT
H	Condensate Line	1/2" NPT



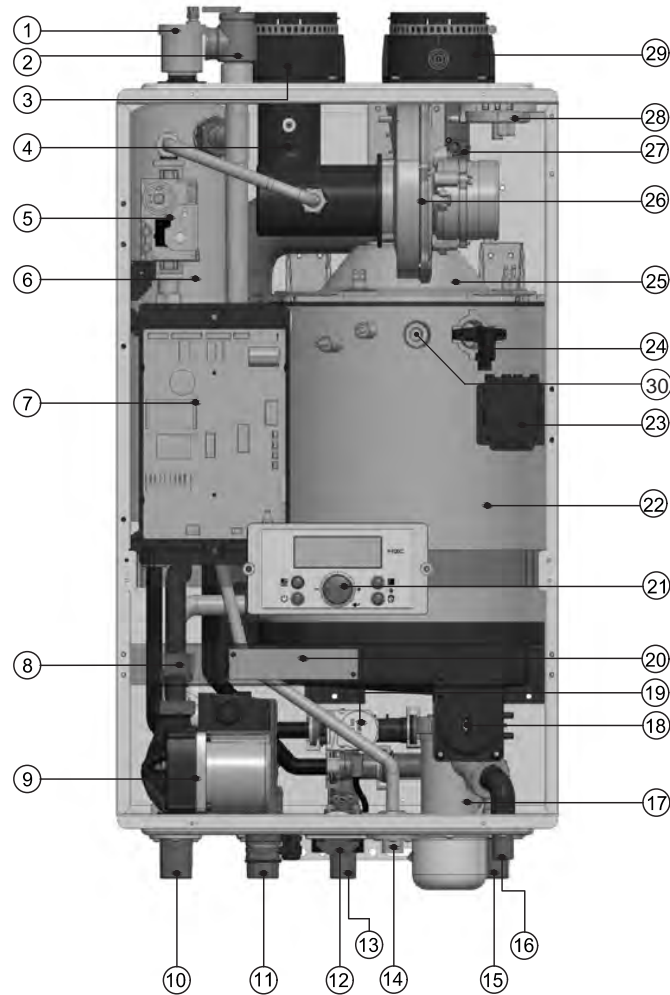
2.3 Dimensions FTCW199



	Description	Diameter
A	Air Intake collar	3"
B	Vent Pipe Collar	3"
C	'CH' Supply	1" NPT
D	'CH' Return	1" NPT
E	'DHW' Outlet	3/4" NPT
F	'DHW' Inlet	3/4" NPT
G	Gas Inlet	3/4" NPT
H	Condensate Line	1/2" NPT

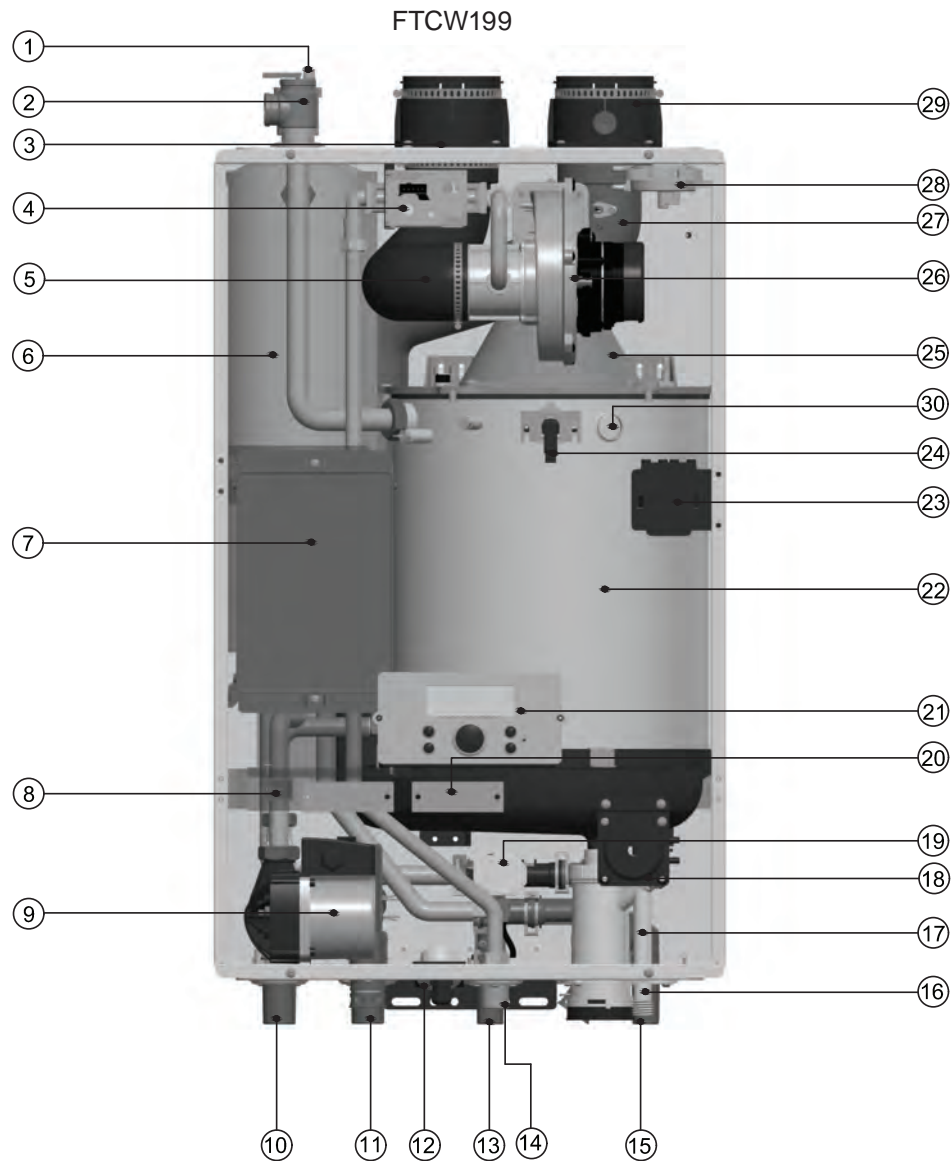
## 2.4 Names of Components

FTCW140



#	Name of Component
1	Air Vent (air eliminator)
2	Pressure Relief Valve
3	Air Intake Collar
4	Air Gas Mixing Pipe
5	Gas Valve
6	DHW Water Tank
7	Main PCB
8	Manual Power Switch (ON / OFF)
9	Recirculation Pump DHW / CH Primary Pump
10	'CH' Supply Connection
11	'CH' Return Connection
12	CH Pressure Gauge
13	DHW Outlet Connection
14	Gas Inlet Connection
15	DHW Inlet Connection (filter and flow restrictor)

#	Name of Component
16	Condensate Connection
17	Condensate Trap
18	Air Pressure Switch (condensate)
19	Mixing Valve
20	Terminal Block
21	Control Panel and Display
22	Heat Exchanger
23	Ignition Trans
24	Flame Detecting Sensor
25	Burner Case
26	BLDC Fan (Blower)
27	Vent Pipe
28	Air Pressure Switch
29	Vent Pipe Collar
30	Sight Glass



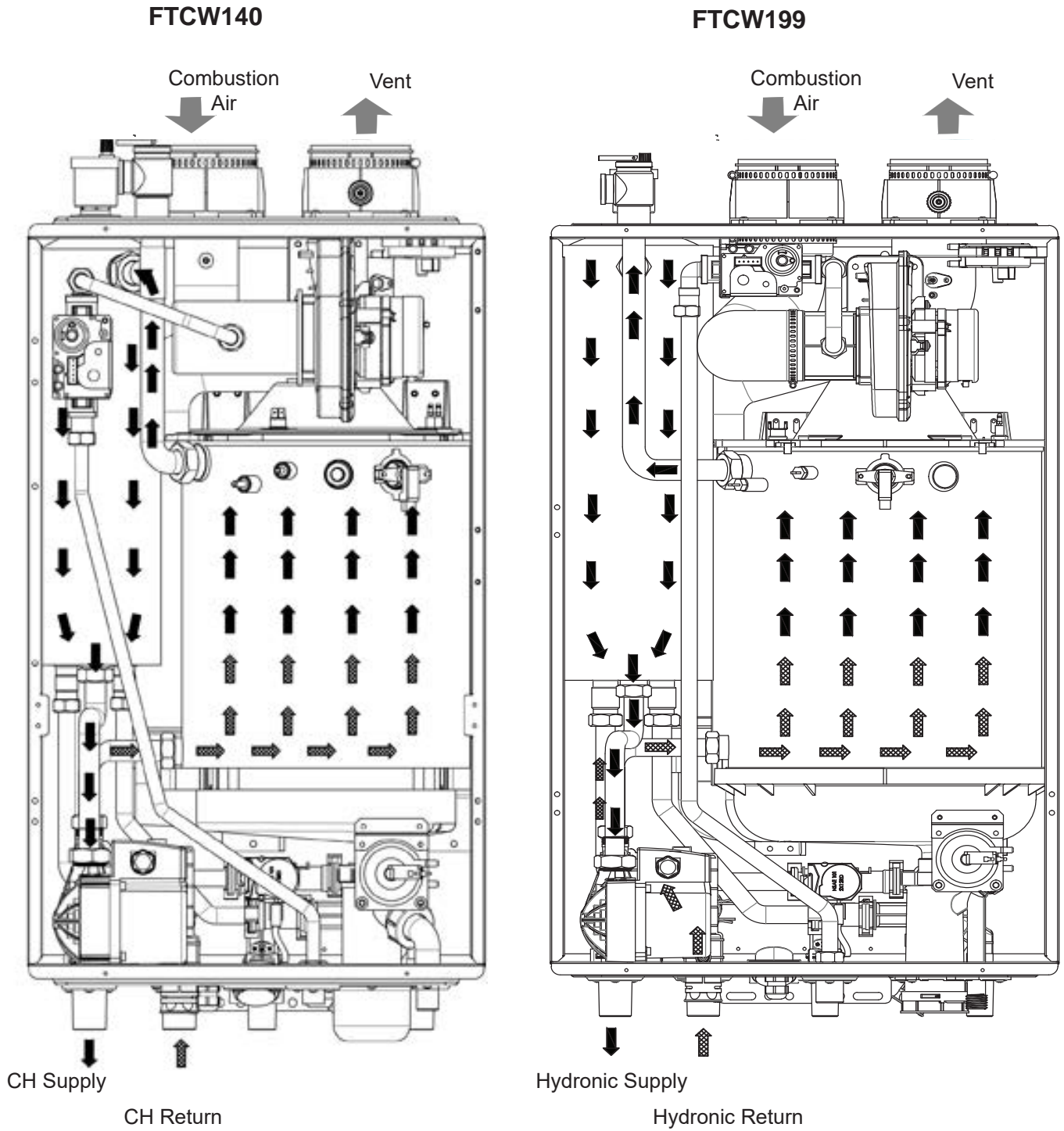
#	Name of Component
1	Air Vent (air eliminator)
2	Pressure Relief Valve
3	Air Intake Collar
4	Gas Valve
5	Air Gas Mixing Pipe
6	DHW Water Tank
7	Main PCB
8	Manual Power Switch (ON / OFF)
9	Recirculation Pump DHW / CH Primary Pump
10	'CH' Supply Connection
11	'CH' Return Connection
12	CH Pressure Gauge
13	DHW Outlet Connection
14	Gas Inlet Adapter
15	DHW Inlet Connection (filter and flow restrictor)

#	Name of Component
16	Condensate Connection
17	Condensate Trap
18	Air Pressure Switch (condensate)
19	Mixing Valve
20	Terminal Block
21	Control Panel and Display
22	Heat Exchanger
23	Ignition Trans
24	Flame Detecting Sensor
25	Burner Case
26	BLDC Fan (Blower)
27	Vent Pipe
28	Air Pressure Sensor
29	Vent Pipe Collar
30	Sight Glass

## 2.5 Product Flow Paths and Characteristics

### 2.5.1 Central Heating flow. Combination Boiler Heating Mode.

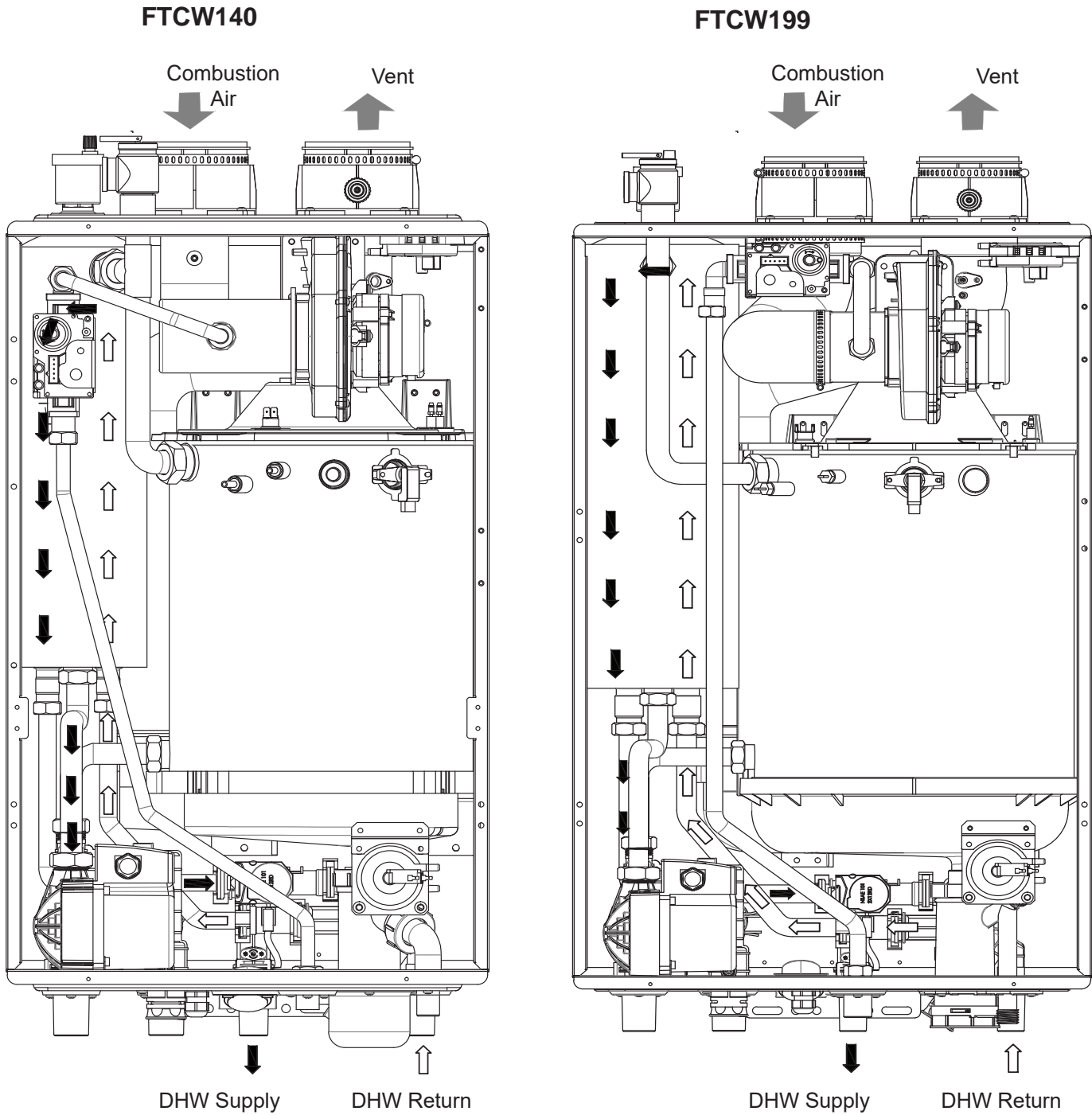
Water in the heating pipe is used for space heating.



## 2.6 Product Flow Paths and Characteristics

### 2.6.1 Domestic Hot Water flow. Combination Boiler Domestic Hot Water Mode.

Cold water passes through the exchanger and is heated via a mini indirect tank. The domestic hot water (DHW) is provided on demand.



## SECTION 3 Safety Regulations

### 3.1 Safety Symbols

#### WARNING

To avoid product damage, personal injury, or even possible death, carefully read, understand, and follow all the instructions in the Installation and Operation manual before installation, operation and service the Boiler.

Manufacturer cannot anticipate every circumstance that might involve a potential hazard. Therefore, all possible incidents are not included in our warnings. Proper installation, operation, and service are your responsibility. You must make sure that the operation and settings of the Boiler are safe for you and for others.

This manual provides Safety Symbols. When the user fails to adhere to the following requirement, it may cause death, serious injury, and substantial property damage.

For safety symbols, 'DANGER', 'WARNING', 'CAUTION' are indicated and the definitions for these terms are as follow:

#### DANGER

Indicates an imminently hazardous situation which, if not avoided, will result in death or serious injury. This signal word is limited to the most extreme situations.

#### WARNING

Indicates a potentially hazardous situation which, if not avoided, could result in death or serious injury.

#### CAUTION

Indicates a potentially hazardous situation which, if not avoided, may result in minor or moderate injury. It is also used to alert against unsafe practices and hazards involving only property damage.

#### WARNING

Cancer and Reproductive Harm.  
[www.P65WARNINGS.CA.GOV](http://www.P65WARNINGS.CA.GOV).

as required by the state of California Proposition 65.

#### WARNING

##### FOR YOUR SAFETY READ BEFORE OPERATING

If you do not follow these instructions exactly, a fire or explosion could result causing property damage, personal injury or loss of life.

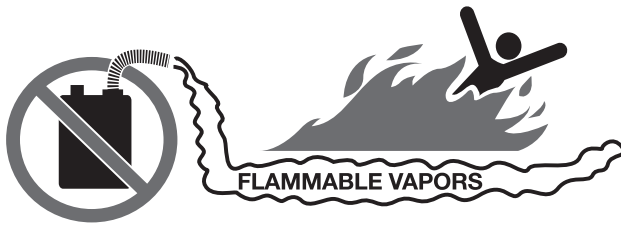
- A. This appliance does not have a pilot. It is equipped with an ignition device which automatically lights the burner. Do not try to light the burner by hand.
- B. BEFORE OPERATING smell all around the appliance area for gas. Be sure to smell next to the floor because some gas is heavier than air and will settle on the floor.

##### WHAT TO DO IF YOU SMELL GAS

- Do not try to light any appliance.
  - Do not touch any electric switch; do not use any phone in your building.
  - Immediately call your gas supplier from a neighbor's phone. Follow the gas supplier's instructions.
  - If you cannot reach your gas supplier, call the fire department.
- C. Use only your hand to push in or turn the gas control knob. Never use tools. If the knob will not push in or turn by hand, don't try to repair it, call a qualified service technician. Force or attempted repair may result in a fire or explosion.
  - D. Do not use this appliance if any part has been under water. Immediately call a qualified service technician to inspect the appliance and to replace any part of the control system and any gas control which has been under water.

This appliance must be installed in accordance with local codes if any; if not, follow ANSI Z224.1/NFPA 54 or CAN/CSA B149.1, Natural Gas and Propane Installation Code, as applicable.

- This appliance is certified for use at altitudes up to 4,500ft(1,370m) in accordance to the latest CSA/CGA 2.17-M91 Gas-Fired Appliances for Use at High Altitudes.



**⚠ DANGER**

- Vapors from flammable liquids will explode and catch on fire. These will cause death or severe burns.

Do not use or store flammable products such as gasoline, solvents or adhesives in the same room or area near the appliance.

Keep flammable products

- Far away from boiler
- In approved containers
- Tightly closed
- Out of children’s reach

Vapors

- Cannot be seen
- are heavier than air
- spread on the floor
- Can spread from other rooms to the main burner by air currents

Do not install the appliance where flammable products will be stored.  
Read and follow boiler warnings and instructions thoroughly. If owner’s manual is missing, contact the retailer or manufacturer.

- This combination boiler must be installed by a qualified plumber, a licensed gas fitter, and/or a professional service technician. Improper installation and/or operation will cause a potentially hazardous situation, such as serious injury or death. Also, it will void the warranty.
  - The National Fuel Gas Code NFPA 54 / ANSI Z224.1
  - National Electric Code ANSI/NEPA 70
  - All applicable local, state, national and provincial codes, regulations and laws.
- Proper care is your responsibility. Carefully read and understand the Operating Information in this manual before operating the Boiler.
- Be aware of the location of the gas shut-off valve and operation method. Close the gas shut-off valve immediately if the appliance is subjected to fire, overheating, flood, physical damage, or any other

damaging condition that might affect the operation of the unit. Boiler must be checked by a qualified technician before resuming operation.

- DO NOT use this Boiler if any part has been under water. Immediately call a qualified technician for inspecting the Boiler and replacing any part of the control system and gas control which have been under water.
- Do not power up the unit until the gas and water supply valves are fully opened. Make sure that the fresh air intake port and exhaust gas port are opened and functional.
- DO NOT attempt to install, repair, or service this Boiler by yourself. Do not change any part of the Boiler. Contact a qualified technician if the Boiler needs repair or maintenance. Ask your gas supplier for a list of qualified service providers.
- DO NOT use spray paint, hair spray, or any other flammable spray near Boiler or near the exterior fresh air inlet port. DO NOT place any items in or around the exterior exhaust gas outlet port and/or fresh air inlet port. These could restrict or block the flow in or out of the vent system.
- “Caution: While repairing control, all wires are labeled. You must connect the wires in accordance with the instruction. Wiring errors can cause improper and dangerous operation.
- “Verify proper operation after servicing operation”
- This consists of the gas ignition system components which are protected from water (dripping, spraying, rain, etc.) during operation and service (circulator replacement, condensate trap, control replacement, etc.).
- After installing the heater, safety devices must be tested.
- This boiler is equipped with a blocked vent shutoff system. If the error code ‘41’ occurs, follow the instructions below.
  - First, turn off the manual gas valve.
  - Make sure that there is no foreign object in the vent passage or rodent screen.
  - If you do not find any problem, do the following.
  - Turn off the error state by pressing the power button of control panel.
  - If the error occurs repeatedly, call your service technician or gas supplier.

## 3.2 Safety Precautions and Proper Use

### Before Operation

#### 1. Check the Gas Type (NG/LP)

When using or moving the unit for the first time, check if gas type matches with the gas type of the Boiler. Check whether the gas type which is supplied is NG (Natural Gas) or LP (Propane) and also check the Boiler gas type.

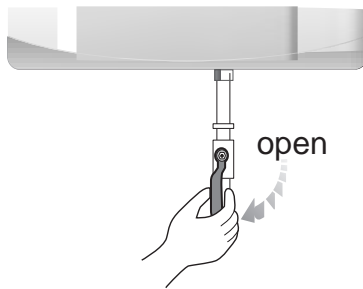
The gas type is indicated on the rating plate on side of the Boiler.

#### 2. Check the Power (120V 60Hz)

Check that the appliance is connected properly.

#### 3. Check the Cold Water Inlet valve

Please keep the appliance water inlet valve open at all times. The appliance will not ignite when insufficient water or no water is in the heating pipes. (valve: always open position)



#### 4. Check the Gas Valve

Check that the manual gas shut-off valve that supplies the FT is opened.

5. Check the area around the appliance and remove any combustible or flammable materials. Remove laundry or any other items that are on or near the boiler or vent pipe.

### When in Operation



#### 1. Caution for Gas leak

Frequently check for a gas leak at the gas connection portion with soapy water.

Steps to take if you have a Gas leak.

1. Shut down the boiler as soon as gas fumes are detected.
2. Close the intermediate gas valve.
3. Open windows for ventilation.
4. Call a qualified service technician for immediate repair.

#### 2. Caution for Ventilation

Make sure that there is sufficient inflow and outflow of air ventilation while using the unit.

If the ventilation is improper, combustion quality may deteriorate inside the appliance and cause shortened life of the appliance.

#### 3. Burn Warning

Be careful not to burn yourself on the flue or pipes. They become extremely hot during operation.



**⚠ WARNING**

Do not use the appliance for any other purpose than for heating and hot water.  
Do not store combustibles or flammable material such as gasoline near the appliance.  
Do not store other items on or near this boiler.  
Do not store combustible (flammable) materials such as papers.  
Do not hang clothes on the vent pipe. This may start a fire.

**⚠ CAUTION**

**Scalding Risk: Manufacturer strongly recommends the use of an anti-scald mixing valve at domestic hot water outlet (boiler location) to reduce potential for scalding. Contact Manufacturer for recommended models. Check with local codes.**



- After repair of gas pipeline or gas regulator replacement, call A qualified contractor for inspection before starting it up.

**Carbon monoxide poisoning**

If vent pipe fumes enter the room, it could cause poisoning by carbon monoxide gas. Check that the vent pipes are properly connected. Open windows for ventilation. Call a qualified service technician for immediate repair.

**Gas leakage test.**

Gas supply line must be inspected regularly.

**Do not shut off the Boiler.**

When you leave home for a long time, do not shut off Boiler. The Boiler has a freeze protection function. The ceramic heater is installed inside of the heater's internal pipe to protect the heater from freezing.

Do not wipe the appliance or control panel with wet cloth. Electric shock may occur, or internal parts may fail due to the exposure to moisture.

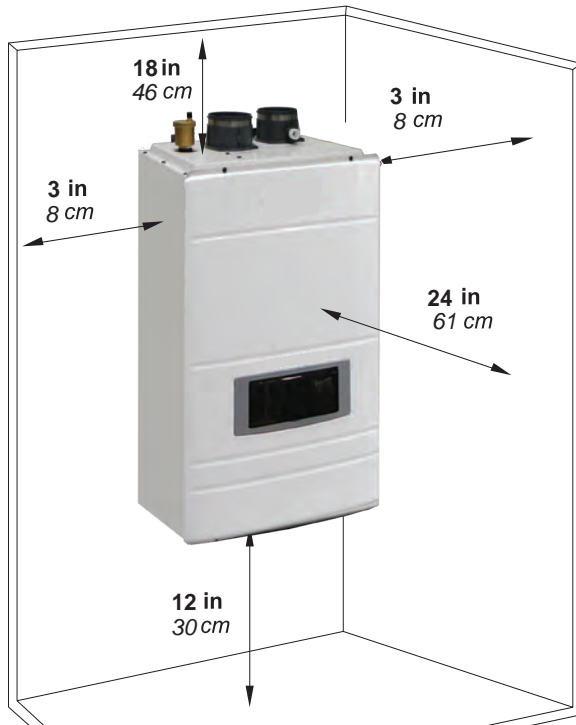
**Do not disassemble the Boiler.**

If repair is required, call your local qualified technician.

## SECTION 4 Installation

### 4.1 Location and Clearances

The FT must be mounted to a suitable wall by a qualified heating contractor under the guidelines of a boiler. The wall may be of concrete or wood. Suitable fasteners for concrete or wood must be used. Failure to wall mount this boiler using correct fasteners will affect the performance and life expectancy of the boiler and will void the warranty.



Minimum clearances to Combustibles.

For Installation from Non-Combustibles and Combustibles		Suggested Service Clearance
TOP of appliance	18 in (46 cm)	18 in (46 cm)
BACK of appliance	5/8 in (1.5 cm)	5/8 in (1.5 cm)
FRONT of appliance	24 in (61 cm)	40 in (101 cm)
SIDE of appliance	3 in (7 cm)	8 in (20 cm)
BOTTOM of appliance	12 in (30 cm)	24 in (61 cm)

**Table 1. Minimum Clearances to Combustibles and for Service.**

#### WARNING

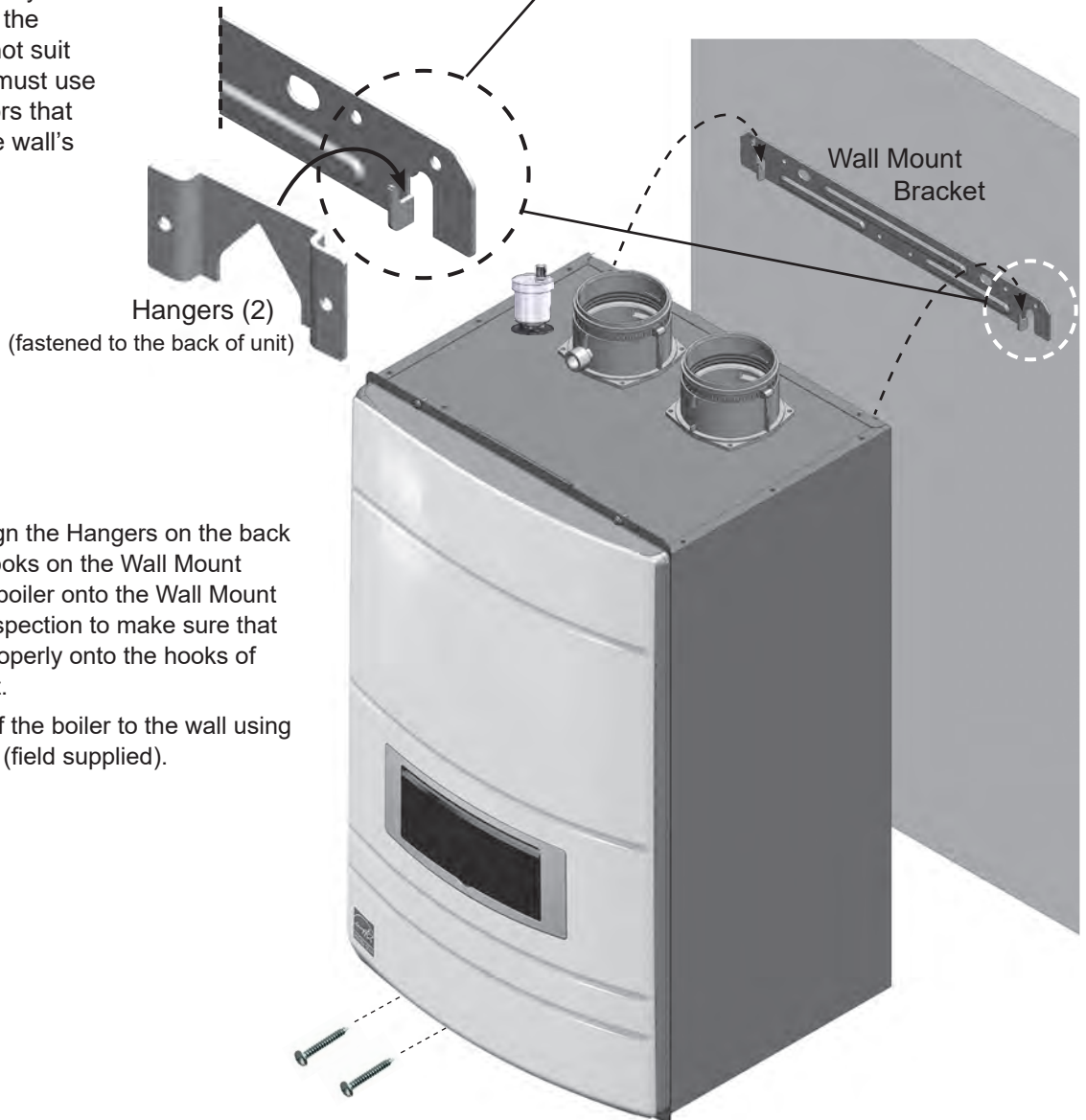
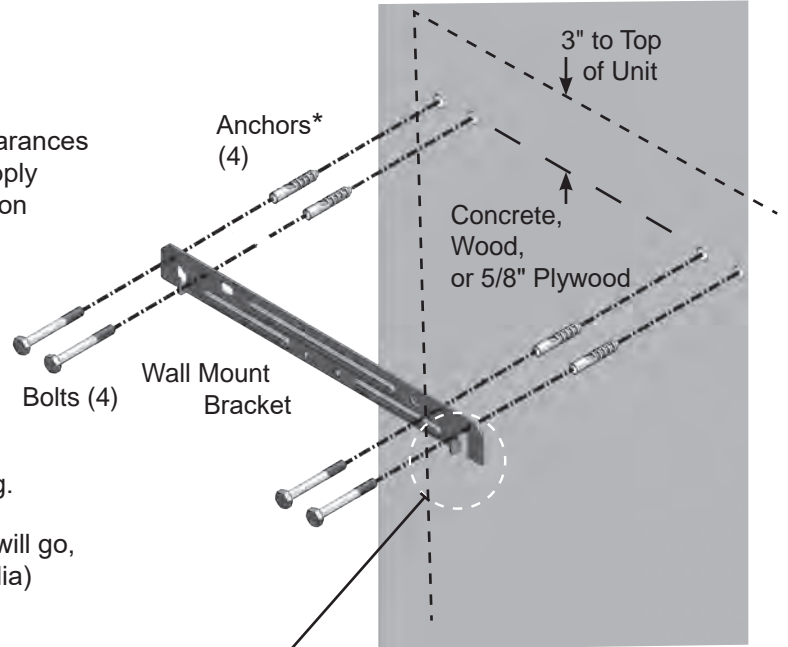
- Installations must comply with
  - All the local, state, provincial, and national codes, laws, regulations and ordinances.
  - National Fuel Gas Code, ANSI Z223.1 – The latest version.
  - National Electrical Code.
  - A National Standard of Canada CAN/CSA-B149.1
- Check before placing the Combination boiler
  - Always check the connected components which are near to the heater. The components are below.
- Water piping position / Venting adapter / Gas supply piping / Electrical power / Condensate drain hose.
  - Inspect area around Combination boiler. Remove any combustible materials, gasoline and other flammable liquids. Failure to keep Combination boiler area clear and free of combustible materials, gasoline and other flammable liquids and vapors can result in severe personal injury, death or substantial property damage.
  - The Combination boiler which has gas control system components must be protected from any possible danger during operation and service.
  - If new Combination boiler replaces an existing appliance, check and correct system problems, for example:
    - Do not install if: System leaks causing oxygen corrosion or heat exchanger cracks from hard water deposits.
- Provide clearances
  - If the heater was installed in a narrow space or corner, please ensure that there is sufficient space for service and maintenance access. For regular maintenance, gas and water lines must be accessible.
- The boiler must be installed on a wall that can bear its weight.

#### WARNING

- CLEARANCES FOR SERVICE ACCESS
  - If you do not provide the minimum clearances shown, it might not be possible to service the boiler without removing it from the space.
  - Space must be provided with combustion / ventilation air openings correctly sized for all other appliances located in the same space as the boiler. The boiler cover must be securely fastened to prevent it from drawing air from the boiler room. This is particularly important if the boiler is in a room with other appliances. Failure to comply with the above warnings could result in substantial property damage, severe personal injury, or death.

**4.2 Wall Mount Bracket**

- **The installation height and location** for your FT depends on your installation scenario. With all clearances considered, and given adequate positioning for air supply and venting, you will need to determine the best position to mount the Wall Mount Bracket. The wall must be concrete, wood, or plywood over studs, and must be strong enough to hold the boiler!
- Start by familiarizing yourself to how the included Wall Mount Bracket hooks underneath the two Hangers that are attached to the back of the boiler. The 'hooks' of the Wall Mount Bracket will be 3" from the Top of the boiler once the boiler is hung.
- Position the Wall Mount Bracket at the location that it will go, being sure that it is level, and then drill 4 holes (0.47" dia) with a 1/2" drill bit, into the wall through the Bracket.
- If mounting to a concrete wall, then use the concrete anchors. If onto wood or 5/8" (16 mm) plywood, then use the wood screws. Do not hang the FT onto sheetrock unless it is possible to fasten directly into the structural studs. If the included anchors do not suit your installation, you must use 'Field Supplied' anchors that are appropriate for the wall's construction.



**Hang the Boiler**

- Lift the boiler up, align the Hangers on the back of the boiler with the hooks on the Wall Mount Bracket, and hang the boiler onto the Wall Mount Bracket. Do a visual inspection to make sure that the boiler is hanging properly onto the hooks of the Wall Mount Bracket.
- Fasten the bottom of the boiler to the wall using 2 suitable wall anchors (field supplied).

### 4.3 Combustion Air

FT boilers must have provisions for combustion and ventilation air in accordance with the applicable requirements for Combustion Air Supply and Ventilation in the National Fuel Gas Code, ANSI Z223.1; or in Canada, the Natural Gas and Propane Installation Code, CSA B149.1. All applicable provisions of local building codes must also be adhered to.

**A FT unit can take combustion air from the space in which it is installed, or the combustion air can be ducted directly to the unit. Ventilation air must be provided in either case.**

#### 4.3.1 Combustion Air from Room

In the United States, the most common requirements specify that the space shall communicate with the outdoors in accordance with method 1 or 2, which follow. Where ducts are used, they shall be of the same cross-sectional area as the free area of the openings to which they connect.

**Method 1:** Two permanent openings, one commencing within 12" (300mm) of the top and one commencing within 12" (300mm) of the bottom, of the enclosure shall be provided. The openings shall communicate directly, or by ducts, with the outdoors or spaces that freely communicate with the outdoors. When directly communicating with the outdoors, or when communicating to the outdoors through vertical ducts, each opening shall have a minimum free area of 1 square inch per 4000 Btu/hr (550 square mm/kW) of total input rating of all equipment in the enclosure. When communicating to the outdoors through horizontal ducts, each opening shall have a minimum free area of not less than 1 square inch per 2000 Btu/hr (1100 square mm/kW) of total input rating of all equipment in the enclosure.

**Method 2:** One permanent opening, commencing within 12" (300mm) of the top of the enclosure, shall be permitted. The opening shall directly communicate with the outdoors or shall communicate through a

vertical or horizontal duct to the outdoors or spaces that directly communicate with the outdoors and shall have a minimum free area of 1 square inch per 3000 Btu/hr (734 square mm/kW) of the total input rating of all equipment located in the enclosure. This opening must not be less than the sum of the areas of all vent connectors in the confined space.

Other methods of introducing combustion and ventilation air are acceptable, providing they conform to the requirements in the applicable codes listed above.

In Canada, consult local building and safety codes or, in absence of such requirements, follow CAN/CGA B149.1

#### 4.3.2 Ducted Combustion Air

The combustion air can be taken through the wall, or through the roof. When taken from the wall, it must be taken from out-of-doors by means of the horizontal wall terminal. When taken from the roof, a field-supplied rain cap or an elbow arrangement must be used to prevent entry of rain water.

Use ABS, PVC, CPVC, polypropylene, or galvanized pipe for the combustion air intake. Route the intake to the boiler as directly as possible. Seal all joints. Provide adequate hangers. The unit must not support the weight of the combustion air intake pipe. Maximum linear pipe length allowed is shown in [Table 5](#). Subtract 5 allowable linear ft. (1.5m) for every elbow used.

The connection for the intake air pipe is at the top of the unit.

In addition to air needed for combustion, air shall also be supplied for ventilation, including air required for comfort and proper working conditions for personnel.

### COMBUSTION AIR INSTALLATION STANDARDS

MATERIAL	UNITED STATES	CANADA
ABS	ANSI/ASTM D1527	Air pipe material must be chosen CPVC, sch 40, ANSI/ASTM, Polypropylene based upon the intended application of the boiler.
PVC, sch 40	ANSI/ASTM D1785 or D2665	
CPVC, sch 40	ANSI/ASTM F441	
Polypropylene	UL1738, ULC S636.	
Single wall galv. steel	26 gauge	

**Table 2. Required Combustion Air Pipe Material.**

**⚠ NOTICE**

The instructions for the installation of the venting system shall specify that the horizontal portions of the venting system shall be supported to prevent sagging; the methods of and intervals for support shall be specified. These instructions shall also specify that the venting system:

Category I, II and IV boilers must be installed so that horizontal sections have a slope of at least ¼ inch per foot (21 mm/m) to prevent accumulation of condensate; and

For Category II and IV boilers, where necessary, have means provided for drainage of condensate.

**⚠ CAUTION**

- The FT is standard as a Natural Gas Boiler and must be converted if propane is the desired gas, unless specifically manufactured for propane.
- Adequate drainage
  - The appliance should be installed not to damage the adjacent area. If such locations cannot be avoided, it is recommended that a suitable drain pan, adequately drained, be installed under the appliance. The pan must not block combustion air flow.
- Connecting the Water Supply
  - To conserve water and energy, insulate all water piping—especially the hot and recirculation water lines. Never cover the drain or pressure relief valve. Having a backflow preventer in the cold water supply line will prevent thermal expansion backflow. Contact the water supplier or local plumbing inspector for information about how to control this situation.
- If overheating occurs or the gas supply fails to shut off, turn off the manual gas valve.
- This installation must conform with below section
  - “Air for Combustion and Ventilation” of the National Fuel Gas Code, ANSI Z224.1/NFPA 54, or Sections 8.2, 8.3 or 8.4 of Natural Gas and Propane Installation Code, CAN/CSA B149.1, or applicable provisions of the local building codes.

**⚠ AVIS**

Les instructions d'installation du système d'évacuation doivent préciser que les sections horizontales doivent être supportées pour prévenir le fléchissement. Les méthodes et les intervalles de support doivent être spécifiés. Les instructions doivent aussi indiquer les renseignements suivants:

les chaudières de catégories I, II et IV doivent présenter des tronçons horizontaux dont la pente montante est d'au moins ¼ po par pied (21 mm/m) entre la chaudière et l'évent; les chaudières de catégories II et IV doivent être installées de façon à empêcher l'accumulation de condensat;

et si nécessaire, les chaudières de catégories II et IV doivent être pourvues de dispositifs d'évacuation du condensat.

## 4.4 Venting (Exhaust)

### NOTICE

**DO NOT COMMON VENT FT UNITS. FT units are never permitted to share a vent with Category I appliances.**

### AVIS

**NE PAS ÉVENT COMMUNE FT UNITÉS. FT unités ne sont jamais autorisés à partager un évent Catégorie I avec les appareils.**

The flue temperature of the FT changes dramatically with changes in operating water temperature. Therefore, it is necessary to assess the application of the boiler to determine the required certified vent class. If the FT is installed in an application where the ambient temperature is elevated, and/or installed in a closet/alcove, CPVC, polypropylene, or stainless steel material is required. If the system temperatures are unknown at the time of installation, stainless, polypropylene or CPVC material is recommended.

The FT is a Category IV appliance and may be installed with PVC, CPVC or polypropylene that complies with ULC-S636, ANSI/ASTM D1785 F441 (see [Table 3](#)) or a stainless steel venting system that complies with UL 1738 Standard and ULC S636.

### WARNING

Failure to use the appropriate vent material, installation techniques, glues/sealants could lead to vent failure causing property damage, personal injury or death.

### WARNING

All venting must be installed according to this manual and any other applicable local codes, including but not limited to, ANSI Z224.1/NFPA 54, CAN/CSA B149.1 and ULC-S636. Failure to follow this manual and applicable codes may lead to property damage, severe injury, or death.

### WARNING

Use of cellular core PVC (ASTM F891), cellular core CPVC, or Radel® (polyphenolsulfone) in non-metallic venting systems is prohibited and covering non-metallic vent pipe and fittings with thermal insulation is prohibited.

**INSTALLATIONS IN CANADA** require the use of venting material certified to ULCS636. All Gas vents connected to the FT, plastic, stainless steel or otherwise must be certified to this ULC standard. Appropriate selection of vent material is very important for proper performance and safe operation of the FT.

The flue temperature of the FT changes dramatically with changes in operating water temperature. Therefore, it is necessary to assess the application of the boiler to determine the required certified vent class. If the FT is installed in an application where the outlet water temperature exceeds 145°F, and/or installed in a closet, class IIB or higher vent material is required. If the system temperatures are unknown at the time of installation, class IIB or higher venting material is recommended.

**IN CANADA** all venting used must meet the following requirements:

1. ULC-S636 certified and marked
2. The first 3 feet of venting must be accessible for visual inspection.
3. All components used in the vent system must be from a certified manufacturer.

### VENTING INSTALLATION STANDARDS

MATERIAL	UNITED STATES	CANADA
Stainless Steel	UL 1738	Venting must be ULC-S636 certified for use as venting material. The venting material must be chosen based upon the intended application of the boiler.
PVC, sch 40	ANSI/ASTM D1785	
CPVC, sch 40	ANSI/ASTM F441	
Polypropylene	UL1738 or ULC-S636	

**Table 3. Required Exhaust Vent Material.**

- 4. Vent system components must not be mixed with alternate manufacturers certified components and/or unlisted components.
- 5. The venting must be installed according to the vent manufacturers installation instructions.

The unit's vent can terminate through the roof, or through an outside wall.

Vent pipe must pitch upward, toward the vent terminal, not less than 1/4" per foot, so that condensate will run back to the FT to drain. Route vent pipe to the heater as directly as possible. Seal all joints and provide adequate hangers as required in the venting system manufacturer's Installation Instructions. Horizontal portions of the venting system must be supported to prevent sagging and may not have any low sections that could trap condensate. The unit must not support the weight of the vent pipe.

**⚠ WARNING**

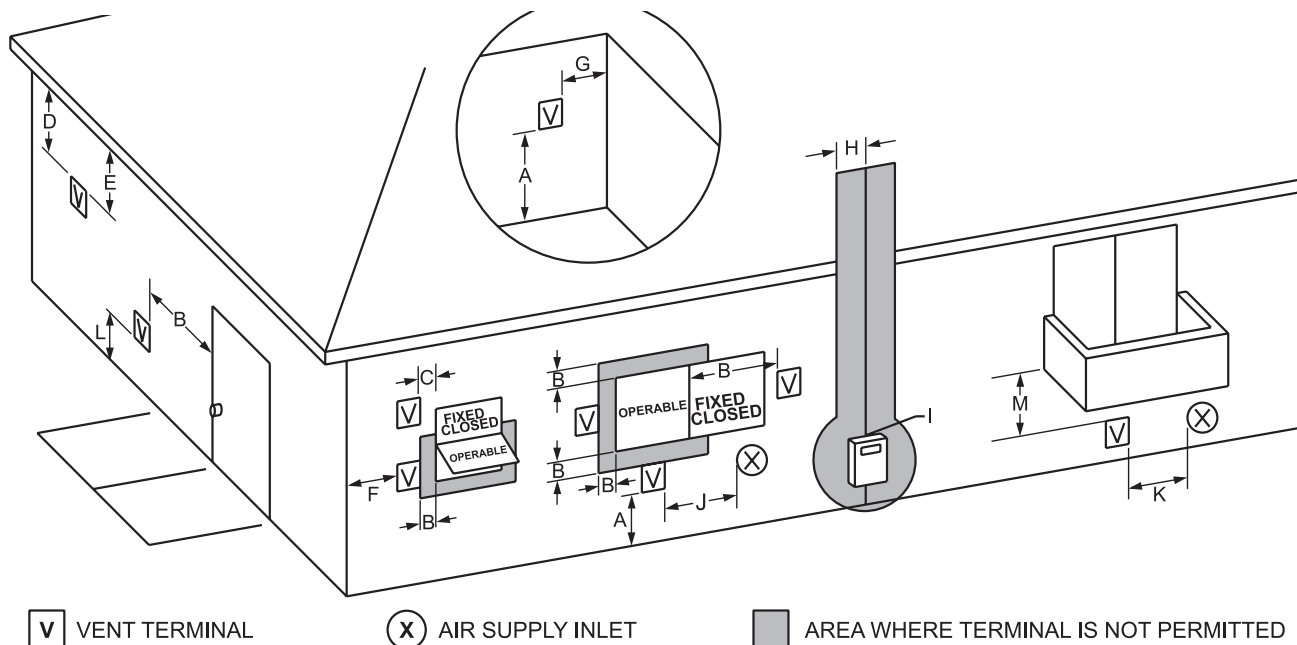
- Failure to vent this Boiler in accordance with these instructions could cause a fire, resulting in severe property damage, personal injury or death.
- Do not interchange vent systems or materials unless it is specified.
- The use of thermal insulation covering pipe and fittings is prohibited.
- Do not apply an electric damper, draft hood or vent damper with this Boiler.
- Do not locate vent termination where exposed to prevailing winds. Moisture and ice may fall on surface around vent termination. To prevent deterioration, surface must be in good repair (sealed, painted, etc.).

**4.5 General Location Guideline**

- 1. Vent system installation must be in accordance with Local codes or, in the absence of local codes, the National Fuel Gas Code, ANSI Z224.1 /NFPA 54 and/or CSA B149.1, Natural Gas and Propane Installation Code.
- 2. The Boiler is designed to be installed as a Direct Vent (sealed combustion) type. The air for combustion must be supplied directly from the outside to the burner. Also, the flue gases must be vented directly to the outdoors (through wall or roof).
- 3. Do not install venting system components on the exterior of building except as specifically required by these instructions
  - Vent terminals must be at least 1 foot from any door, window, or gravity inlet into the building.
  - Maintain the correct clearance and orientation between the vent and air intake terminals. The vent and air intake terminals must be at the same height and their center lines must be spaced apart 12" minimum.
  - The bottom of the vent and air intake terminal must be at least 12" above the normal snow line. In no case should they be less than 12" above grade

- level.
  - Do not install the vent terminal directly over windows or doors.
  - Air intake terminal must not terminate in areas that might contain combustion air contaminants, such as near swimming pools.
  - For sidewall venting, the minimum horizontal distance between any adjacent individual Module (Boiler) vent terminations is twelve (12) inches. It is better to be far more than 12 inches for avoiding frost damage to building surfaces where vent terminations are placed.
  - The minimum horizontal distance between any adjacent individual module (boiler) roof vent endpiece is one (1) foot.

## 4.6 Locations for Vent Pipe Terminator



### 4.6.1 Direct Venting Clearances

	U.S. Installations (see note 1)	Canadian Installations (see note 2)
<b>A=</b> Clearance above grade, veranda, porch, deck, or balcony	12 inches (30 cm) See note 6	12 inches (30 cm) See note 6
<b>B=</b> Clearance to window or door that may be opened	Direct vent only: 12 inches (30cm); Other than Direct vent: 4 ft (1.2m) below or to side of opening; 1 ft (30cm) above opening	36 inches (91 cm) NT 80 only - 12 inches (30 cm)
<b>C=</b> Clearance to permanently closed window	See note 4	See note 5
<b>D=</b> Vertical clearance to ventilated soffit located above the terminal within a horizontal distance of 2 feet (61cm) from the center line of the terminal	See note 4	See note 5
<b>E=</b> Clearance to unventilated soffit	See note 4	See note 5
<b>F=</b> Clearance to outside corner	See note 4	See note 5
<b>G=</b> Clearance to inside corner	See note 4	See note 5
<b>H=</b> Clearance to each side of center line extended above meter/regulator assembly	See note 4	3 feet (91 cm) within a height 15 feet above the meter/regulator assembly
<b>I=</b> Clearance to service regulator vent outlet	See note 4	3 feet (91 cm)
<b>J=</b> Clearance to nonmechanical air supply inlet to building or the combustion air inlet to any other appliance	Direct vent only: 12" (30cm) 80-285; 36" (91cm) 399-850. Other than Direct vent: 4 ft (1.2m) below or to side of opening; 1 ft (30cm) above opening	36 inches (91 cm) NT 80 only - 12 inches (30 cm)
<b>K=</b> Clearance to a mechanical air supply inlet	3 feet (91 cm) above if within 10 feet (3 m) horizontally	6 feet (1.83 m)
<b>L=</b> Clearance above paved sidewalk or paved driveway located on public property	Vent termination not allowed in this location for category IV appliances.	7 ft (2.1 m) See note 5
<b>M=</b> Clearance under veranda, porch, deck, or balcony	See note 4	12 inches (30 cm) (see note 3)
<b>Notes:</b>		
1. In accordance with the current ANSI Z223.1 / NFPA 54 National Fuel Gas Code.		
2. In accordance with the current CAN/CSA-B149.1 Installation Codes.		
3. Permitted only if veranda, porch, deck, or balcony is fully open on a minimum of two sides beneath the floor.		
4. For clearances not specified in ANSI Z223.1 / NFPA 54, clearance is in accordance with local installation codes and the requirements of the gas supplier.		
5. For clearances not specified in CAN/CSA-B149, clearance is in accordance with local installation codes and the requirements of the gas supplier.		
6. IMPORTANT: Terminal must be placed such that it remains a minimum 12" above expected snow line. Local codes may have more specific requirements, and must be consulted.		

**Table 4. Direct Vent Clearances**



#### **4.6.2 Venting Requirements in the Commonwealth of Massachusetts**

In Massachusetts the following items are required if the side-wall exhaust vent termination is less than seven (7) feet above finished grade in the area of the venting, including but not limited to decks and porches. From Massachusetts Rules and regulations 248 CMR 5.08

1. Installation of Carbon Monoxide Detectors

At the time of installation of the side wall vented gas fueled appliance, the installing plumber or gasfitter shall observe that a hard-wired carbon monoxide detector with an alarm battery back-up is installed on the floor level where the gas appliance is to be installed. In addition, the installing plumber or gasfitter shall observe that a battery operated or hard-wired carbon monoxide detector with an alarm is installed on each additional level of the dwelling, building or structure served by the side-wall horizontally vented gas fueled equipment. It shall be the responsibility of the property owner to secure the services of qualified licensed professionals for installation of hard-wired carbon monoxide detectors.

a. In the event that the side-wall horizontally vented gas fueled equipment is installed in a crawl space or an attic, the hard-wired carbon monoxide with alarm and battery back-up may be installed on the next adjacent floor level.

b. In the event that the requirements of the

subdivision cannot be met at the time of completion of installation, the owner shall have a period of thirty (30) days to comply with the above requirements, provided, however, that during said thirty (30) day period, a battery operated carbon monoxide detector with an alarm be installed.

2. Approved Carbon Monoxide Detectors

Each carbon monoxide detector shall comply with NFPA 720 and be ANSI/UL 2034 listed and IAS certified.

3. Signage. A metal or plastic identification plate shall be permanently mounted to the exterior of the building at a minimum height of eight (8) feet above grade directly in line with the exhaust vent terminal for horizontally vented gas fueled heating appliance or equipment. The sign shall read, in print no less than one-half (1/2) inch in size: "GAS VENT DIRECTLY BELOW, KEEP CLEAR OF ALL OBSTRUCTIONS".

4. Inspection The state or local gas inspector of the side-wall horizontally vented gas fueled appliance shall not approve the installation unless, upon inspection, the inspector observes carbon monoxide detectors and signage installed in accordance with the provisions of 248 CMR 5.08(2)(a) 1-4.

## 4.7 Common Vent Test

NOTE: This section does not describe a method for common venting FT units. It describes what must be done when an existing unit is **removed** from a common vent system.

### NOTICE

At the time of removal of an existing boiler, the following steps shall be followed with each appliance remaining connected to the common venting system placed in operation, while the other appliances remaining connected to the common venting system are not in operation.

1. Seal any Not Used openings in the common venting system.
2. Visually inspect the venting system for proper size and horizontal pitch and determine there is no blockage or restriction, leakage, corrosion and other deficiencies which could cause an unsafe condition.
3. Insofar as is practical, close all building doors and windows and all doors between the space in which the appliances remaining connected to the common venting system are located and other spaces of the building. Turn on clothes dryers and any appliance not connected to the common venting system. Turn on any exhaust fans, such as range hoods and bathroom exhausts, so they will operate at maximum speed.
4. Place in operation the appliance being inspected. Follow the lighting instructions. Adjust thermostat so the appliance will operate continuously.
5. Operate the main burner for 5 minutes then, determine if the cut-draw overflows to the discharge opening. Use the flame of a match or a candle or the smoke of a cigarette, a cigar or a pipe
6. Once it has been determined, according to the method indicated above, that each device connected to the drainage system is placed in the open air in an adequate manner. Install the doors and windows, fans, the registers of chimneys and gas appliances to their original position
7. Any malfunction of the venting system should be corrected so that the installation conforms to the National Fuel Gas Code, ANSI Z223.1/NFPA 54 and (or) the installation codes CAN/CSA-B149.1. If the size of a section of the evacuation system must be changed, the system should be modified to comply with the minimum values of the relevant tables of appendix F of the National Fuel Gas Code, ANSI Z223.1/NFPA 54 and (or) the installation codes CAN/CSA-B149.1

### NOTICE

**DO NOT COMMON VENT FT UNITS. FT units are never permitted to share a vent with Category I appliances.**

### AVIS

Au moment du retrait d'une chaudière existante, les mesures suivantes doivent être prises pour chaque appareil toujours raccordé au système d'évacuation commun et qui fonctionne alors que d'autres appareils toujours raccordés au système d'évacuation ne fonctionnent pas:

1. Sceller toutes les ouvertures non utilisées du système d'évacuation.
2. Inspecter de façon visuelle le système d'évacuation pour déterminer la grosseur et l'inclinaison horizontale qui conviennent et s'assurer que le système est exempt d'obstruction, d'étranglement, de fuite, de corrosion et autres défaillances qui pourraient présenter des risques.
3. Dans la mesure du possible, fermer toutes les portes et les fenêtres du bâtiment et toutes les portes entre l'espace où les appareils toujours raccordés au système d'évacuation sont installés et les autres espaces du bâtiment. Mettre en marche les sècheuses, tous les appareils non raccordés au système d'évacuation commun et tous les ventilateurs d'extraction comme les hottes de cuisinière et les ventilateurs des salles de bain. S'assurer que ces ventilateurs fonctionnent à la vitesse maximale. Ne pas faire fonctionner les ventilateurs d'été. Fermer les registres des cheminées.
4. Mettre l'appareil inspecté en marche. Suivre les instructions d'allumage. Régler le thermostat de façon que l'appareil fonctionne de façon continue.
5. Faire fonctionner le brûleur principal pendant 5 min ensuite, déterminer si le coupe-tirage déborde à l'ouverture de décharge. Utiliser la flamme d'une allumette ou d'une chandelle ou la fumée d'une cigarette, d'un cigare ou d'une pipe.
6. Une fois qu'il a été déterminé, selon la méthode indiquée ci-dessus, que chaque appareil raccordé au système d'évacuation est mis à l'air libre de façon adéquate. Remettre les portes et les fenêtres, les ventilateurs, les registres de cheminées et les appareils au gaz à leur position originale.
7. Tout mauvais fonctionnement du système d'évacuation commun devrait être corrigé de façon que l'installation soit conforme au National Fuel Gas Code, ANSI Z223.1/NFPA 54 et (ou) aux codes d'installation CAN/CSA-B149.1. Si la grosseur d'une section du système d'évacuation doit être modifiée, le système devrait être modifié pour respecter les valeurs minimales des tableaux pertinents de l'appendice F du National Fuel Gas Code, ANSI Z223.1/NFPA 54 et (ou) les codes d'installation CAN/CSA-B149.1

### AVIS

**NE PAS ÉVENT COMMUNE FT UNITÉS. FT unités ne sont jamais autorisés à partager un évent Catégorie I avec les appareils.**

## 4.8 Air Supply and Vent Connections

### 4.8.1 Vent / Air Pipe Lengths

Combination Boiler Model	3" Combustion Air / Vent Pipe	2" Combustion Air / Vent Pipe
	Max	Max
FTCW140/199	100' (30M)	50'* (15M*)

**Table 5. Maximum Vent / Air Pipe Lengths for either 3" or 2" Pipes**

\*Propane models are limited to 25 equivalent feet of 2" vent

NOTE : For each elbow, reduce maximum allowable length

- 5 feet (1.5M) for each 3-inch 90-degree elbow
- 2.5 feet (0.75M) for each 3-inch 45-degree elbow
- 8 feet (2.4M) for each 2-inch 90-degree elbow
- 4 feet (1.2M) for each 2-inch 45-degree elbow
- Maximum of 6 elbows for 3" vent. Max of 4 elbows for 2" vent.

NOTE: When using a 2" vent pipe, DIP Switch 4 must be in the OFF position.

For 3" Pipe vent, the default setting for DIP 4 is ON.

Refer to Section 4.19

#### 4.7.2 Direct Venting

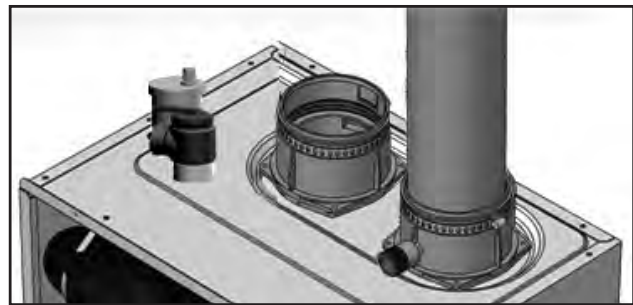
The boiler uses 3" or 2" diameter exhaust and 3" or 2" diameter intake air ducts. To ensure the draw of air directly from and exhaust of air directly to the outside of the building, create an airtight seal from the boiler collar to the vent termination.

**(For installations in Canada)** field-supplied plastic vent piping must comply with CAN/CSA B149.1 (latest edition) and be certified by the Standard For Type BH Gas Venting Systems, ULC-S636. Components of this listed system must not be interchanged with other vent systems or unlisted pipes or fittings. All plastic components and specified primers and glues of the certified vent system must be from a single system manufacturer and must not be intermixed with another system manufacturer's parts.

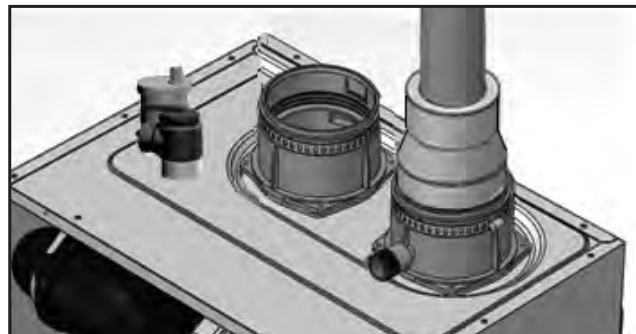
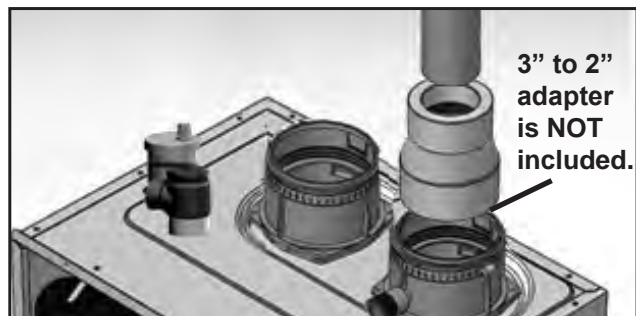
#### ■ Tightening — Boiler Collar (Socket) to Vent Pipe & Inlet Pipe

- Clean and dry your selected PVC, CPVC vent pipe and boiler collar (socket).
- You can select to the size of vent pipe(2" & 3"), according to the installation conditions.
- Push the pipe into the collar (socket) until it touches the bottom of the socket fitting.
- For 2" installations, install a field supplied 3" to 2" adaptor. Adaptor must be installed in vertical section of piping only.

#### 3" pipe



#### 2" pipe connected, using an adapter



### 4.8.2 Indoor Combustion Air

Read and Follow Sections 4.3 Guidelines First.

1. Insert the termination end cap into the intake air duct.
2. Provide two openings to allow for circulation of combustion air as specified by ANSI Z224.1/NFPA 54. In Canada refer to CAN/CSA B-149.1

NOTE: The FT needs fresh air for safe operation and must be installed so there are provisions for adequate combustion and ventilation air.



Model	FTCW140	FTCW199
Maximum Input (BTU/H)	140,000	199,000
Indoor make up air is provided, a minimum free area of 1 in 2 per 1,000 BTU/H	140 in2 13 1/4" (W) x 13 1/4" (H)	199 in2 13 1/4" (W) x 13 1/4" (H)

### 4.9 Vent / Air Pipe Termination

Vent Air Terminations:

After connecting terminals install vent screens on both the vent and air inlet.

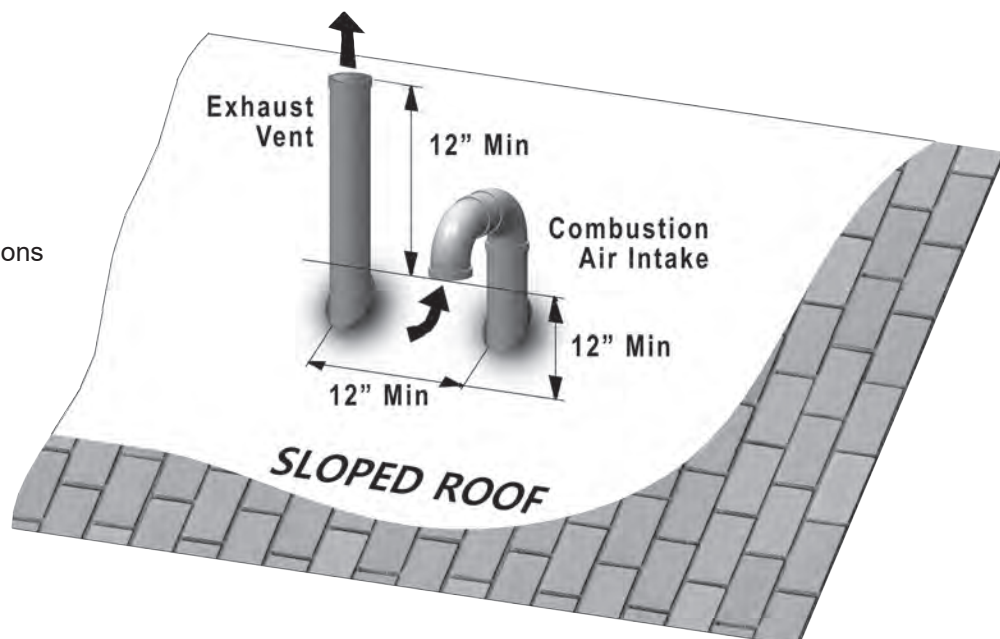
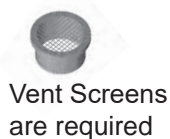
Two 3" vent screens are included with each unit. Additional replacement screens are available for purchase.

2" Vent Screen P/N - FT1508

3" Vent Screen P/N - FT1730

#### Vertical Vent Termination

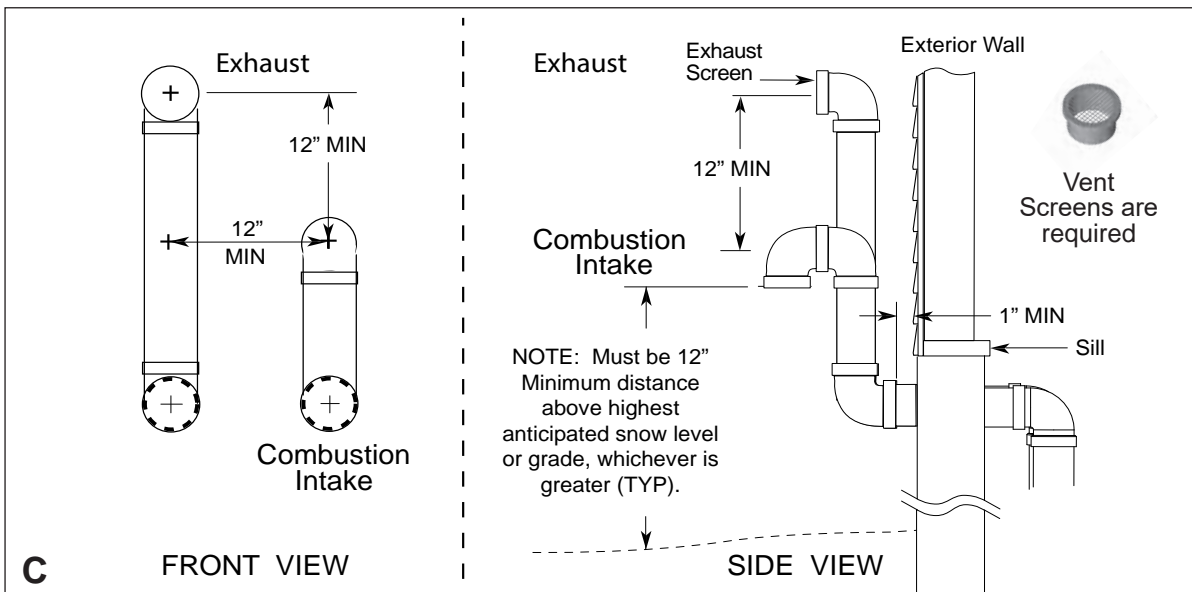
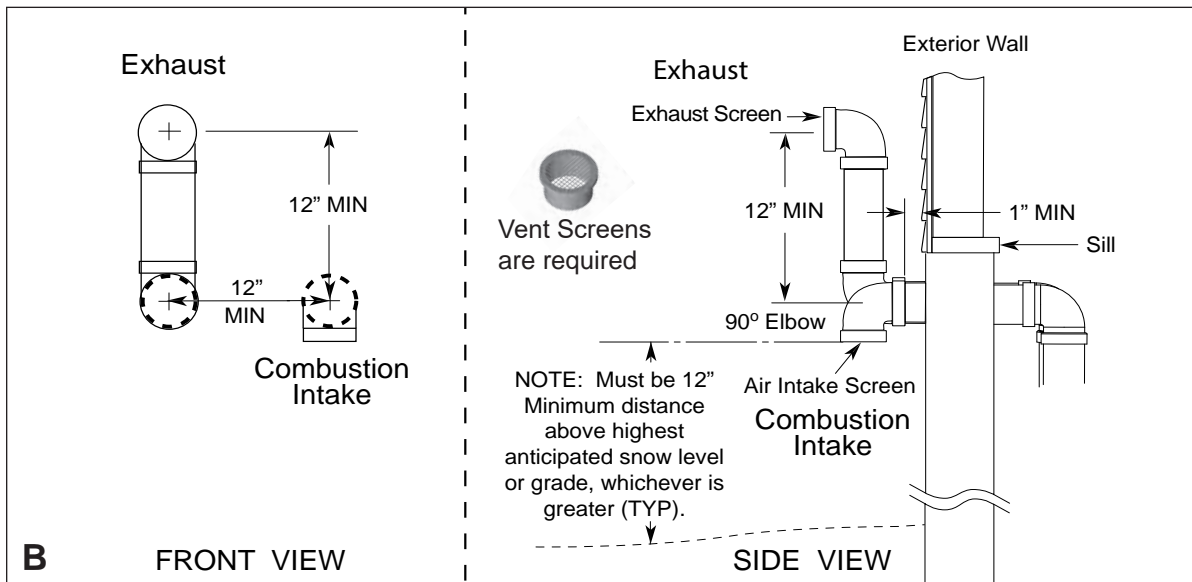
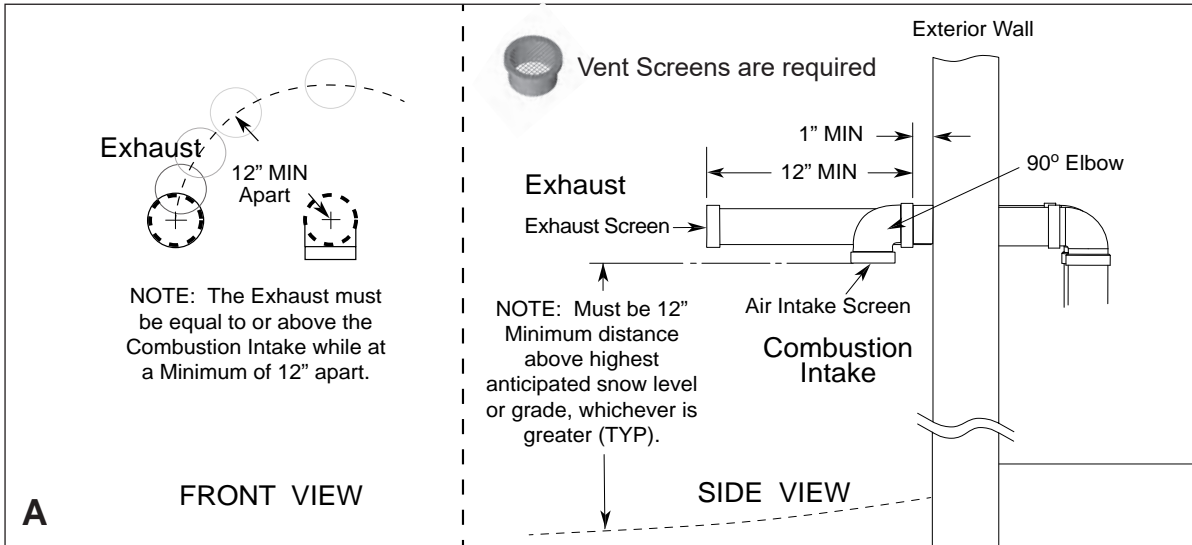
- Direct Vent - Vertical Terminations with Sloped Roof



Horizontal Vent Termination

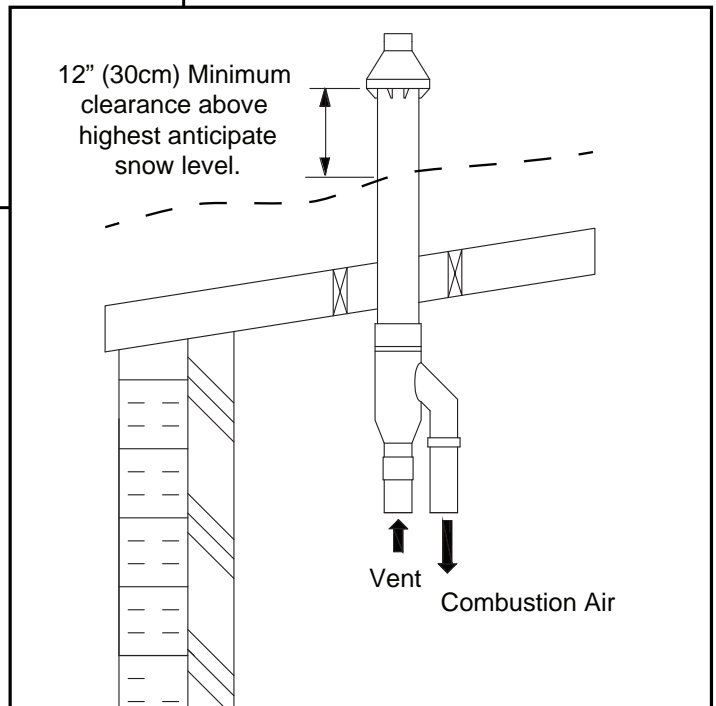
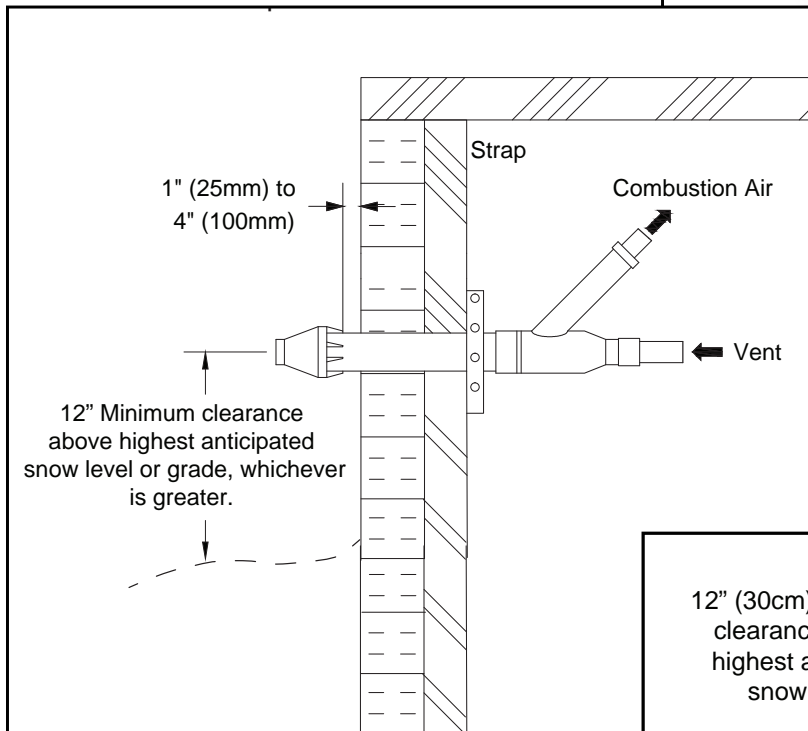
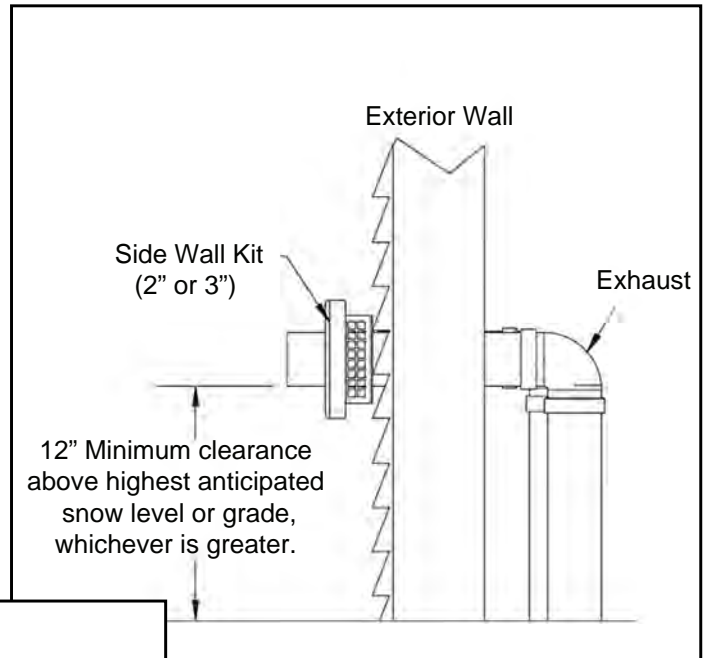
4.8 Vent / Air Pipe Termination (continued)

• Direct Vent - Sidewall Termination



### Concentric Vent Termination

- Direct Vent - Optional Horizontal and Vertical Concentric Vent



### 4.10 Gas Supply and Piping

Gas piping should be supported by suitable hangers or floor stands, not the appliance.

Review the following instructions before proceeding with the installation.

1. Verify that the appliance is fitted for the proper type of gas by checking the rating plate. FT will function properly at elevations up to 10,000 feet (3050 m). Refer to Section 4.12 for High Altitude Settings.
2. For minimum and maximum supply pressures, see Table 9 on page 34
3. Refer to **Table 6**, **Table 7**, and **Table 8** to size piping.
4. Run gas supply line in accordance with all applicable codes.
5. Locate and install manual shutoff valves in accordance with state and local requirements.
6. A sediment trap must be provided upstream of the gas controls.
7. All threaded joints should be coated with piping compound resistant to action of liquefied petroleum gas.
8. The appliance and its individual shutoff valve must be disconnected from the gas supply piping during any pressure testing of that system at test pressures in excess of 1/2 PSIG (3.45kPa).
9. The unit must be isolated from the gas supply system by closing its individual manual shutoff valve during any pressure testing of the gas supply piping system at test pressures equal to or greater than 1/2 PSIG (3.45kPa).
10. The appliance and its gas connection must be leak tested before placing it in operation.
11. Purge all air from gas lines.

**⚠ CAUTION**

PRV (included) must be installed immediately at the top of boiler outlet to PRV, with no valves between. Refer to Section 4.15

**⚠ ATTENTION**

PRV (inclus) doit être installé immédiatement en haut de la chaudière sortie de PRV, sans les vannes entre. Se reporter à la Section 4.15

**⚠ WARNING:**

Open flame can cause gas to ignite and result in property damage, severe injury, or loss of life.

**NOTE:** The FT appliance and all other gas appliances sharing the gas supply line must be firing at maximum capacity to properly measure the inlet supply pressure. The pressure can be measured at the supply pressure port on the gas valve. Low gas pressure could be an indication of an undersized gas meter, undersized gas supply lines and/or an obstructed gas supply line.

SCH 40 METAL PIPE CAPACITY FOR 1.50 SPECIFIC GRAVITY UNDILUTED PROPANE			
NOMINAL PIPE SIZE @ 11" W.C. INLET AND 0.5" W.C. PRESSURE DROP			
SIZE	1/2"	3/4"	1"
LENGTH	MAXIMUM CAPACITY IN THOUSANDS OF BTU PER HOUR		
20	200	418	787
40	137	287	541
60	-	231	434
80	-	197	372
100	-	175	330

**NOTES:** 1. Follow all local and national propane gas codes for line sizing and equipment requirements. 2. Verify that inlet gas pressure remains between 4 and 13 inches of water column before and during operation. Source: ANSI Z223.1-80 National Fuel Gas Code.

**Table 6. Nominal Pipe Size, Propane**

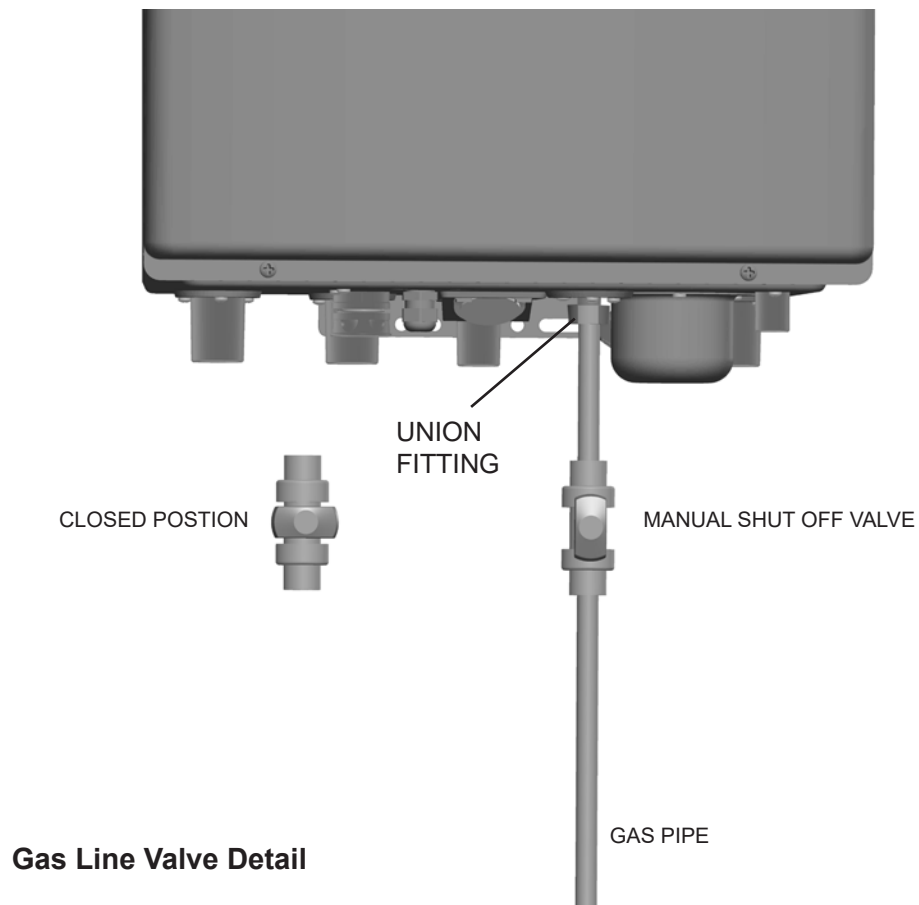
SCH 40 METAL PIPE CAPACITY FOR 0.60 SPECIFIC GRAVITY NATURAL GAS		
NOMINAL PIPE SIZE @ 0.30" W.C. PRESSURE DROP		
LENGTH	3/4"	1"
FT	CUBIC FEET OF GAS PER HOUR	
20	190	350
40	130	245
60	105	195
80	90	170
100		

**Table 7. Nominal Pipe Size, Natural Gas**

EQUIVALENT LENGTHS OF STRAIGHT PIPE FOR TYPICAL SCH 40 FITTINGS			
NOMINAL PIPE SIZE			
FITTING	1/2"	3/4"	1"
LINEAR FEET			
90° ELBOW	3.6	4.4	5.2
TEE	4.2	5.3	6.6

**Table 8. Equivalent Pipe Lengths**

- The gas connection fitting is,
  - 3/4" male NPT** on FTCW140 models
  - 3/4" male NPT** on FTCW199 models
- The supply line must be sized for the maximum output of the combination boiler model being installed. If there are additional gas appliances from the main supply line, you must measure sizes of the supply line according to the COMBINED total maximum BTUH draw for the appliances as if they were all operating at the same time.
- Measure the length of the gas supply line from the gas meter to the Combination boiler. Use the tables in this manual or refer to the gas line manufacturers sizing information to determine the correct supply pipe size.
- The gas shut-off valve in the gas supply line should be installed close to the unit.
- To facilitate any future maintenance, it is also recommended that an approved gas union fitting be installed in the supply line between the shut-off valve and the 3/4" male NPT connection on the Combination boiler.
  - 1) Install an approved gas line pipe to gas line connection under the Combination boiler. Include manual shut off valve and gas union connection, as shown.
  - 2) Test gas pressure to make sure it meets the minimum standards and does not exceed the maximum standards for the combination boiler.
  - 3) Leak test the gas line pipe before placing the unit in operation. Use approved leak detector liquid solutions only to check for leaks.
- Do Not Operate the combination boiler until all connections have been completed, checked for leaks, and the heat exchanger is filled with water.

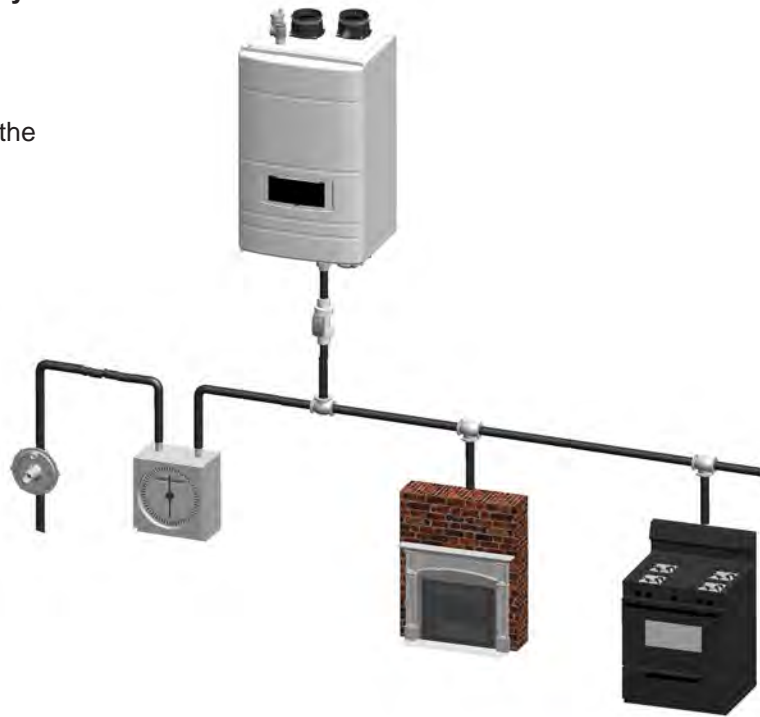




### 4.10 Gas Supply and Piping (cont)

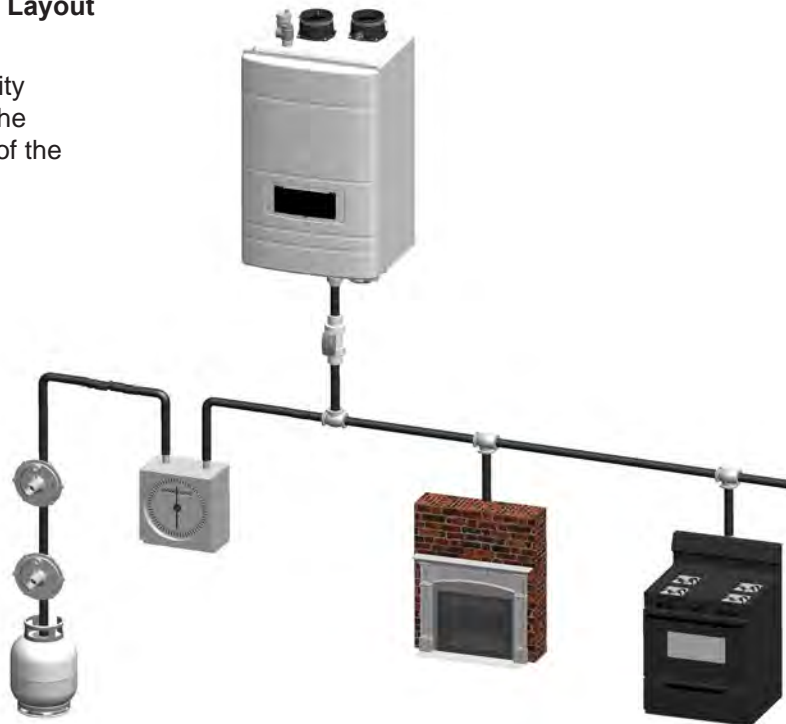
#### Suggested Natural Gas (NG) Layout

NOTE: Total gas supply capacity must not be less than the total demand capacity of the connected appliances.



#### Suggested Propane Gas (LP) Layout

NOTE: Total gas supply capacity must not be less than the total demand capacity of the connected appliances.



- The combination boiler must be installed downstream of the gas meter for adequate gas supply.
- The gas piping must not be less than 1/2" for FTCW140 models and 3/4" female NPT on FTCW199 models.

### 4.11 Gas Supply Pressure

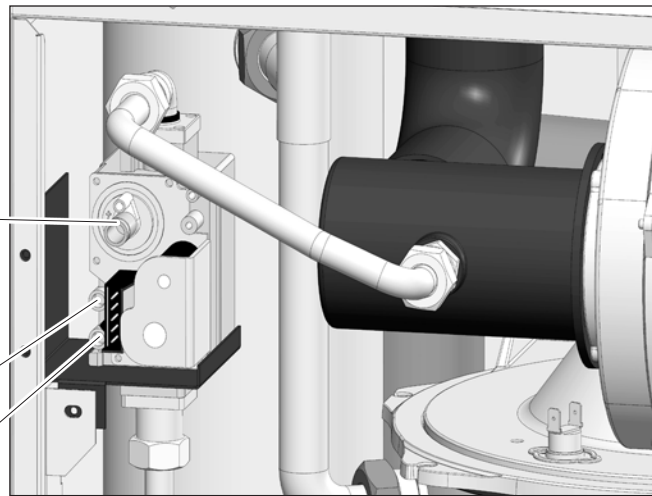
Refer to the illustration.

**Offset Adjustment.**

Do Not Adjust without using a combustion analyzer to verify adjustment. Adjust ONLY when in MIN Fire and when using a combustion analyzer. See Section 4.12 for step by step details.

Gas Outlet / Manifold Pressure Port

Inlet Gas Pressure Port



FTCW140

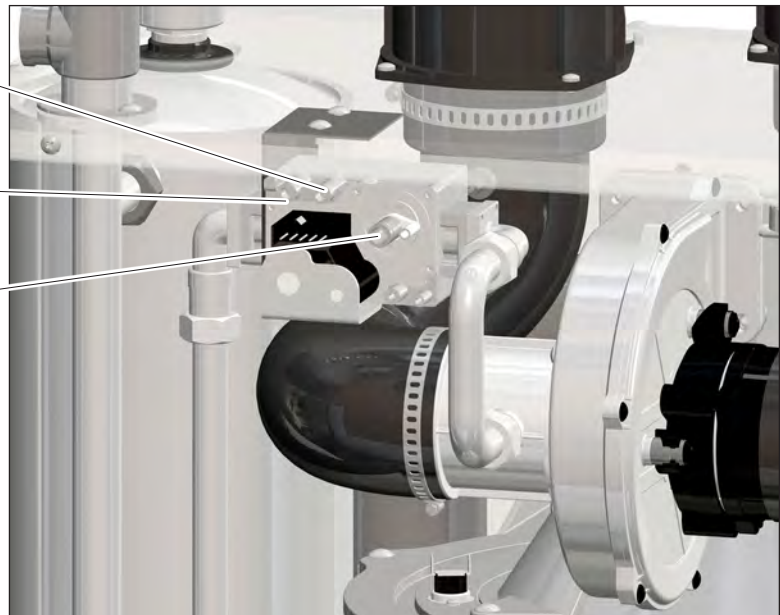
FTCW199

Gas Outlet / Manifold Pressure Port

Inlet Gas Pressure Port

**Offset Adjustment.**

Do Not Adjust without using a combustion analyzer to verify adjustment. Adjust ONLY when in MIN Fire and when using a combustion analyzer. See Section 4.12 for step by step details.



- The Maximum and Minimum gas line pressures must be at Max Fire operation.

LP Gas		Natural Gas	
Maximum Pressure	13.0" WC	Maximum Pressure	10.5" WC
Minimum Pressure	8.0" WC	Minimum Pressure	3.5" WC

**Table 9. Gas Pressures**

**⚠ CAUTION**

- The appliance and its individual shut-off valve must be disconnected from the gas supply piping system during any pressure testing of the system at test pressures in excess of 1/2 psi (3.5 kPa).
- The appliance must be isolated from the gas supply piping system by closing its individual manual shutoff valve during any pressure testing of the gas supply piping system at test pressures equal to or greater than 1/2 psi (3.5 kPa).
- Loosen the pressure port screws before you check the gas inlet pressure.

### 4.12 Adjusting Combustion

1. Using a Phillips screwdriver, remove the 4 screws on the front cover and remove cover.
2. Turn ON the GAS and WATER supply to the FT.
3. Turn ON the FT.
4. Ensure your mascot FT is set for the correct altitude. The default setting is for altitudes of 0~1,999 ft above sea level. If your Mascot FT is installed at an altitude of 2,000 ft, or greater the correct altitude setting should be set according to Section 4.13 of the Mascot FT Install and Operating Manual (document #1318) before you continuing tuning this unit.
5. Connect a manometer to the manifold pressure port. For dual port manometers, use the positive pressure side. Check for proper manifold gas pressure. Refer to table below.
6. Establish a call for heat. You may need to disconnect the outdoor reset if you are making this gas conversion during warm weather.
7. Setup your combustion analyzer and place the sensor into the combustion test port
8. Per Table B for Max Fire, change dip switch 6 to ON and 7 to OFF. The unit will cycle up to MAX fire.
9. WAIT for your combustion analyzer to stabilize. This may take up to 3 minutes depending on your combustion analyzer. Then check the CO2 measurement for MAX fire. Refer to Table 10 for acceptable MAX fire combustion readings Do NOT attempt to adjust CO2 at MAX Fire. ONLY adjust CO2 in MIN Fire operation.
10. Per Table B for MIN Fire, change dip switch 6 to OFF and 7 to ON. The unit will cycle down to MIN Fire.
11. WAIT for your combustion analyzer to stabilize. Then check the CO2 measurement for MIN fire. Refer to Table 10 for acceptable MIN fire combustion readings
12. Open the Gas Valve Adjustment Port by removing the cap screw with a 4mm Allen wrench.
13. Then use the 4 mm Allen wrench to make a minor adjustment (1/8 turn) to either increase or decrease CO2. See 4.11 on page 34

**⚠ WARNING**

NOTE: Installer is required to verify combustion settings as part of the installation process. CO should not exceed 200 ppm.

Standard Factory Setting is for MAX Fire. 9.0% CO2 @ 0-2,000 ft altitude (Natural Gas).

CO <sub>2</sub> value		Natural Gas (NG)		Propane Gas (LP)	
		2" VENT	3" VENT	2" VENT	3" VENT
FTCW (ALL Sizes) ( and all altitudes)	MAX FIRE	8.5 - 10.5%		9.5 - 11%	
	MIN FIRE	8 - 10%		9 - 10.5 %	

**Table 10. CO<sub>2</sub> Values**

Manifold pressure		'NG' type combustibility	'LP' type combustibility
		2"/3" VENT	2"/3" VENT
FTCW140	MAX FIRE	-0.216" WC	-0.216" WC
	MIN FIRE	0.002" WC	0.079" WC
FTCW199	MAX FIRE	-0.314"WC	-0.173"WC
	MIN FIRE	-0.015"WC	-0.015"WC



**Table 11. Manifold Pressures**

14. It may be necessary to go back and forth between HI Fire and LOW Fire several times (and adjusting only at LOW Fire), before CO2 at both are within acceptable levels. Be sure to put the adjustment port cap screw back onto the valve when done.
15. Once the CO2 and manifold pressure measurements for both MIN and MAX Fire are acceptable per Table C, set DIP switches 6 and 7 to the OFF position for Nominal Fire (normal operation).
16. Remove your combustion analyzer from the Test Port and be sure to thread the Test P into position.
17. Re-connect outdoor reset if it was disconnected, put the boiler cover back on and assemble/tighten the 4 screws that hold the cover in place.

### 4.13 High Altitude Installations. 2,000' to 10,000'


The FT is shipped with a default factory setting for installation at an altitude of 0 to 2000' (approx). For maximum efficiencies at higher altitudes (2,000' to 10,000'), the FT does have an adjustment in the Installer Parameters Mode.

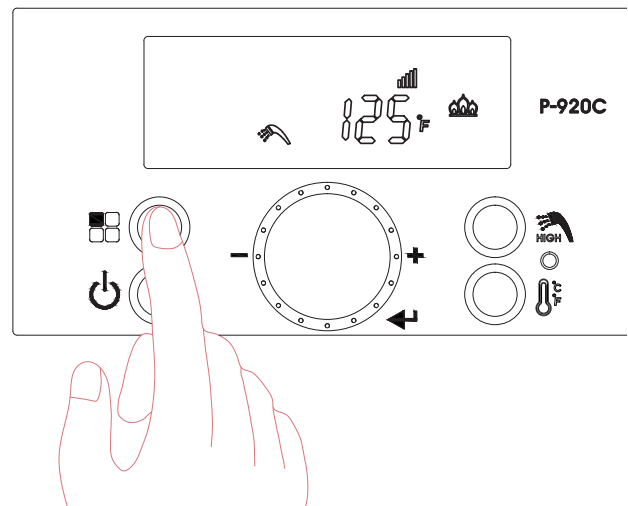
Follow these instructions if your installation is at 2,000' - 10,000'.

1. With the Power  turned OFF, press the 'Modes button'  for 5 seconds to get into the Installer Parameters Mode.
2. Turn the dial (E) until '**28:HA**' appears.
3. Press the dial (E).
4. Set the high altitude value by turning the dial.

#	Altitude of Installation
0	0~1999 ft (0~609 m)
1	2,000~4,499 ft (610~1,645 m)
2	4,500~7,699 ft (1,646~2,346 m)
4	7,700~10,000 ft (2,347~3,048 m)

Refer to table.

5. Press the dial again (E) to save the setting.
6. Press the 'Modes button'  for one second, to Save the number and to go back to initial status.



### 4.14 Natural Gas to Propane Conversion

The FT Series, wall combi, condensing boiler is configured for Natural Gas (NG) from the factory. A Natural Gas to Propane Conversion Kit is included with every FT. The gas conversion kit will show you how to convert your FT boiler to propane gas. If your FT does not have the bag containing the conversion kit, a replacement kit can be obtained. Contact the manufacturer and request a replacement conversion kit.

**NOTICE**

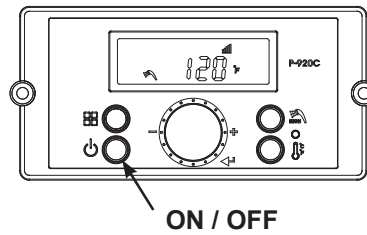
If your installation altitude is greater than 2000 ft, check that the 'High Altitude' Installer Setting has been adjusted to suit your installation altitude.

**WARNING**

This gas conversion kit shall be installed by a qualified service agency in accordance with the manufacturer's instructions and all applicable codes and requirements of the authority having jurisdiction. The information in these instructions must be followed to minimize the risk of fire or explosion or to prevent property damage, personal injury or death. The qualified service agency is responsible for the proper installation of this kit. The installation is not proper and complete until the operation of the converted appliance is checked as specified in the manufacturer's instructions supplied with the kit. Installation must conform to local codes and the latest edition of the National Fuel Gas Code, ANSI Z223.1 and CAN-B149.1. Failure to follow instructions could result in serious injury or property damage. The qualified agency performing this work assumes responsibility for gas conversion.

**CAUTION**

This combination boiler has already been set to burn natural gas, but can be converted to burn LP gas. Before placing the combination boiler into operation, verify that the type of gas supplied to your combination boiler.



#### Steps 1 thru 12

1. Turn OFF the FT. The ON / OFF button is located at the bottom left of the Control Display
2. Turn OFF the GAS and WATER supply to the FT (valves are located on the plumbing pipes.)
3. Using a Phillips screwdriver, remove the 4 screws on the front cover. See Figure A.
4. Locate the Gas Inlet Pipe at the top left of the unit as shown in Figure A, and loosen the Brass Fittings at both ends of the Gas Inlet Pipe.
5. Completely unthread the brass fitting on the blower end of the Gas Inlet Pipe and then carefully swing the Gas Inlet Pipe to the left or right, just enough so that it is out of the way. See Figure B.
6. Remove the existing natural gas nozzle or orifice. If your unit is a 199, note that the flat side of the orifice is towards the blower. Save the packing for re-use. See Figure C.



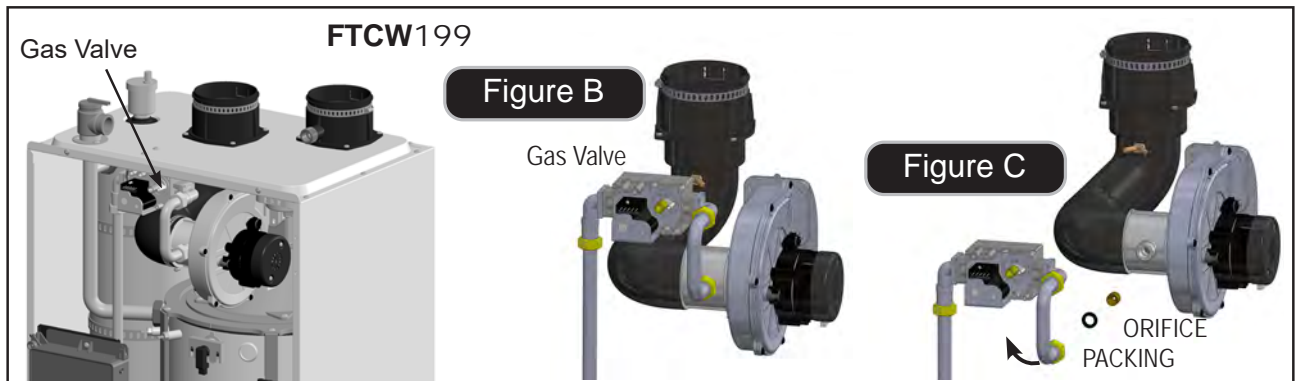
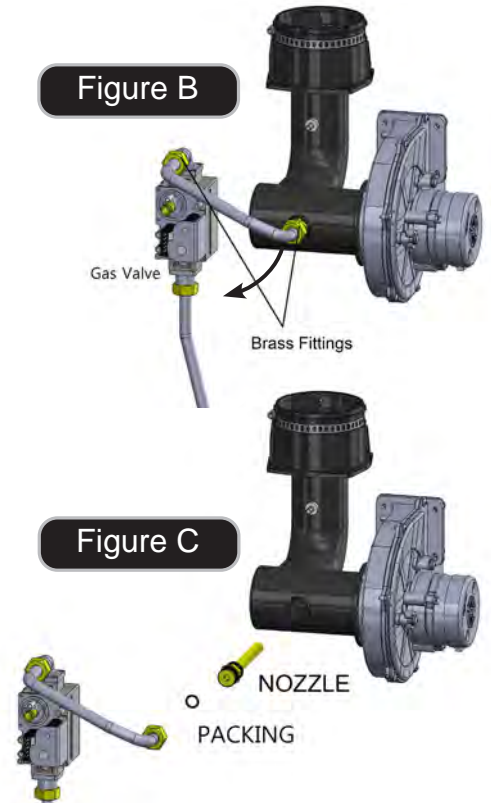
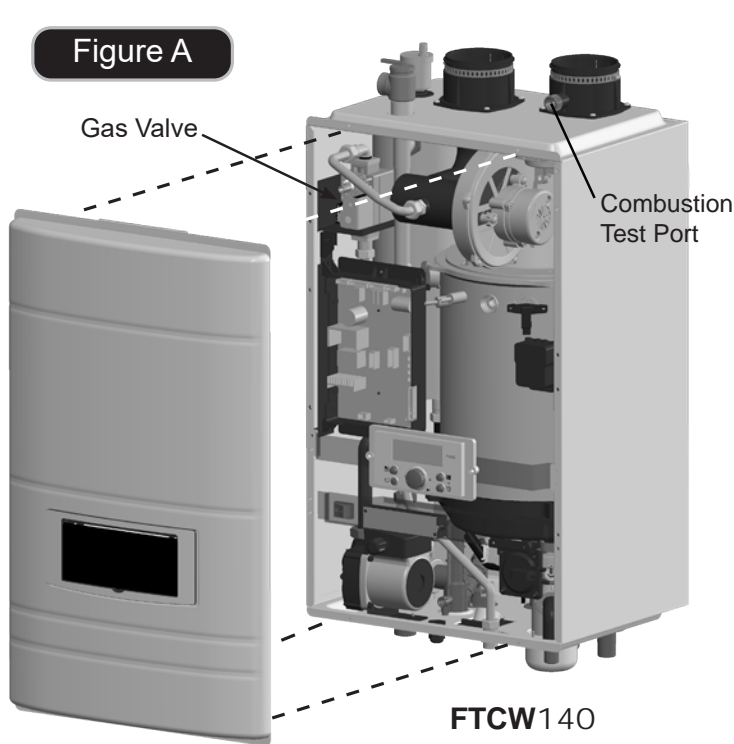
Model	Natural Gas (NG) part #	Propane Gas (LP) part #	
FTCW140	FT1412N	FT1412P	 <b>Nozzle</b>
FTCW199	FT1780	FT1802	 <b>Orifice</b>

Table A. Gas Conversion Parts



**⚠ WARNING**

This conversion shall be installed by a qualified service agency in accordance with the manufacturer's instructions and all applicable codes and requirements of the authority having jurisdiction. If the information in these instructions is not followed exactly, a fire, an explosion or production of carbon monoxide may result causing property damage, personal injury or loss of life. The qualified service agency is responsible for the proper and complete installation of this kit. The installation is not proper and complete until the operation of the converted appliance is checked as specified in the manufacturer's instruction supplied with the kit.



**⚠ AVERTISSEMENT**

Ce conversion doit être installé par un organisme de service conformément aux instructions du fabricant et tous les codes et les exigences de l'autorité compétente. Si les informations contenues dans ces instructions n'est pas suivi à la lettre, un incendie, une explosion ou de la production de monoxyde de carbone mais résultat causant des dommages matériels, des blessures ou des pertes de vie. Le service est responsable pour la bonne et complète l'installation de ce kit. L'installation n'est pas correcte et complète jusqu'à ce que le fonctionnement de l'appareil converti est vérifiée comme spécifié dans le manuel d'instruction fourni avec le kit.

4.14 Natural Gas to Propane Conversion (continued)

ON		OFF	
<b>MIN</b> Fire		Normal Operation	
<b>MAX</b> Fire		Normal Operation	
NG Natural		LP Propane	
3" Vent Size		2" Vent Size	
ON	OFF	ON	ON
ON	OFF	OFF	ON
OFF	ON	ON	ON
MBH 120	<b>140</b>	175	<b>199</b>

**Table B** DIP Switch Settings

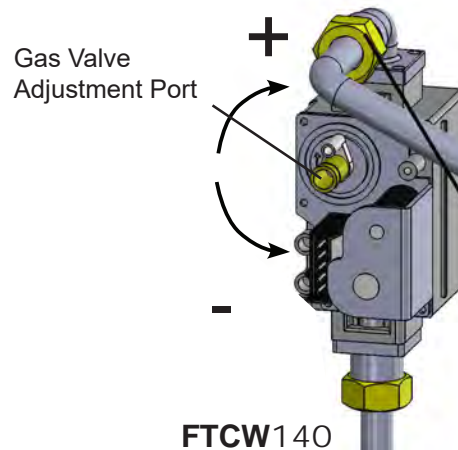


Shown is a Model 140 with 3" Venting and using Natural Gas

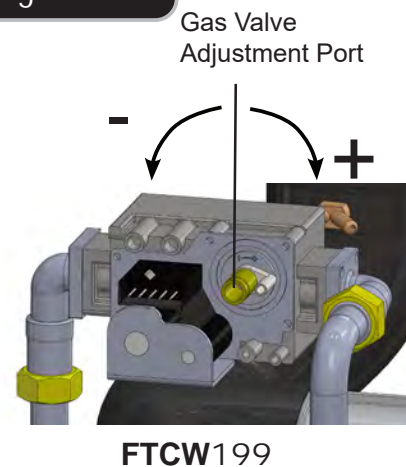


Figure D

- Install the new LP (propane) nozzle or orifice. Re-use the packing from previous.
- Return the Gas Inlet Pipe to its original position and tighten both brass fittings.
- Per Table B, set DIP Switch 5 to OFF for LP Propane.
- Turn ON the GAS and WATER supply to the FT
- Now start the unit and adjust combustion as described in Section 4.12
- Upon completion of set up, write in the correct Conversion Date and the Technicians Name to the included gas conversion sticker. See Figure F. Then apply that sticker adjacent to the rating plate.



Figures E



NOTE: Installer is required to verify combustion settings as part of the installation process.  
CO should not exceed 200 ppm.

CO <sub>2</sub> value		Natural Gas (NG)		Propane Gas (LP)	
		2" VENT	3" VENT	2" VENT	3" VENT
FTCW (ALL Sizes) (and all altitudes)	MAX FIRE	8.5 - 10.5%		9.5 - 11%	
	MIN FIRE	8 - 10%		9 - 10.5 %	

**Table C**

Manifold pressure		'NG' type combustibility	'LP' type combustibility
		2"/3" VENT	2"/3" VENT
FTCW140	MAX FIRE	-0.216" WC	-0.216" WC
	MIN FIRE	0.002" WC	0.079" WC
FTCW199	MAX FIRE	-0.314"WC	-0.173"WC
	MIN FIRE	-0.015"WC	-0.015"WC

**Table D**

This unit was converted on ___/___/___ to ___gas with kit # _____ by _____ (name and company _____ accountable) _____  Cette unité a été converti ___/___/___ ten ___gaz en utilisant le kit numéro _____ par _____ (nom et société _____ responsable) _____ _____
---

**Figure F (Conversion label)**



### 4.15 Plumbing Guidelines

#### 4.15.1 External Plumbing and Water Connection Guidelines

- Ensure pipe material meets local codes and industry standards.
- The pipe end must be clean and free of debris.
- Do not apply torch heat within 12" of the bottom connections of the unit.
- The DHW inlet and outlet connections are 3/4". The CH supply and return connections are 1". The system piping must be a min. of 1-1/4" (see Sections 4.15.4 & 4.15.5 for details).
- Isolation valves (shutoff valve) will be used.
- All piping should be insulated.

#### 4.15.2 Applicable Backflow Preventer

- Apply a backflow preventer valve in the DHW supply inlet (water Inlet) to the unit as required by local codes.

#### 4.15.3 Diaphragm type Expansion tank

- The air in a diaphragm-type expansion tank is separated from the water by a flexible rubber membrane. When the tank is installed in and connected to the piping of the system, water enters the other side of the tank chamber and presses down on the diaphragm.
- You should always install an 'Automatic Air Vent' on the top of the air separator to remove residual air from the system.
- Automatic air vent has been installed on the inside of the boiler.
- The installation of an additional air vent is optional.
- If the boiler is installed in a closed water supply system, such as one having a backflow preventer in the cold water supply line, it will control thermal expansion.

**CAUTION**

- Use at least the MINIMUM pipe size for the entire boiler loop piping (connecting boiler to and from the primary/secondary connection). Use only primary/secondary piping as shown. Failure to follow these guidelines could result in system problems.
- CH pipe minimum size : 1 1/4"
- DWH pipe minimum size : 3/4"

**CAUTION**

For guidelines in the use of Glycol Products. Please refer to Section 8.4 on page 74

**CAUTION**












**Scalding Risk: Manufacturer strongly recommends the use of an anti-scald mixing valve at domestic hot water outlet (boiler location) to reduce potential for scalding. Contact Manufacturer for recommended models. Check with local codes.**

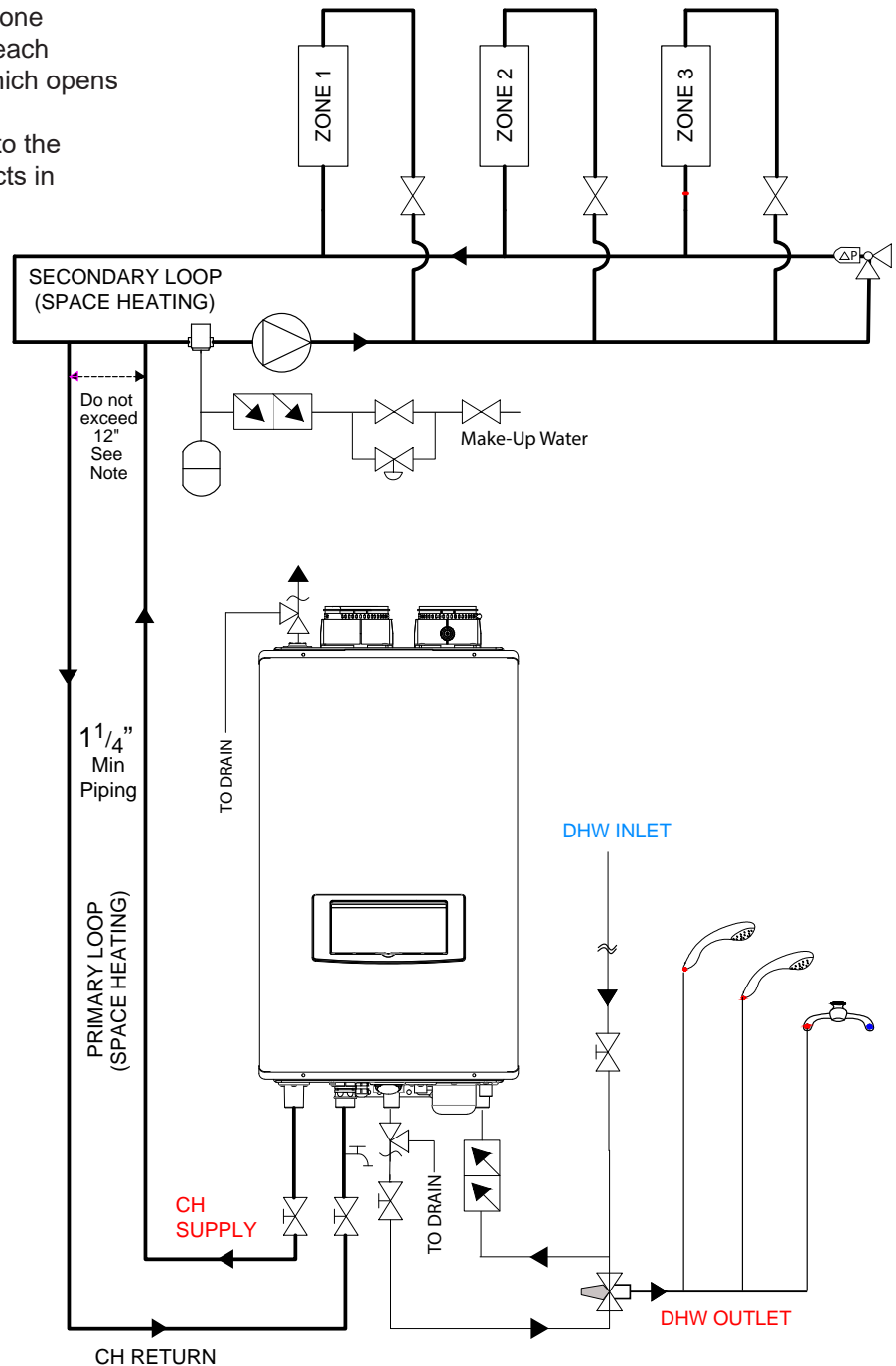


#### 4.15.4 Zoning with zone valves

- In a valve based system, there is one circulator pump at the boiler and each heating zone has a zone valve which opens when the zone demands.
- Each thermostat is wired directly to the corresponding zone valve. Contacts in the zone valves provide a proper signal to the boiler when the valve is opened.

Auto Fill Valve and Backflow Preventer Valves are NOT included (Field Supplied).

	Differential Pressure By-Pass
	Expansion tank (Diaphragm-type)
	Automatic air vent
	Air separator
	Circulation pump
	Check valve
	Drain valve
	valve
	Backflow preventer
	Pressure Relief Valve
	Anti-scald rated Mixing Valve













1. This piping diagram is meant to show system piping concept only. Installer is responsible for all equipment and detailing required by local codes.
2. All closely spaced tees shall be 12" (or 4 pipe dia) center to center spacing.
3. A minimum of 6 pipe diameters of straight pipe shall be installed upstream and downstream of all closely spaced tees.
4. The minimum pipe size of DHW piping should be 3/4" diameter.
5. Install a minimum of 12 diameters of straight pipe upstream of all circulators.
6. Install a check valve on the return line to the boiler.
7. Manufacturer strongly recommends the use of an anti-scald mixing valve at domestic hot water outlet (boiler location) to reduce potential for scalding. Contact Manufacturer for recommended models. Check with local codes.

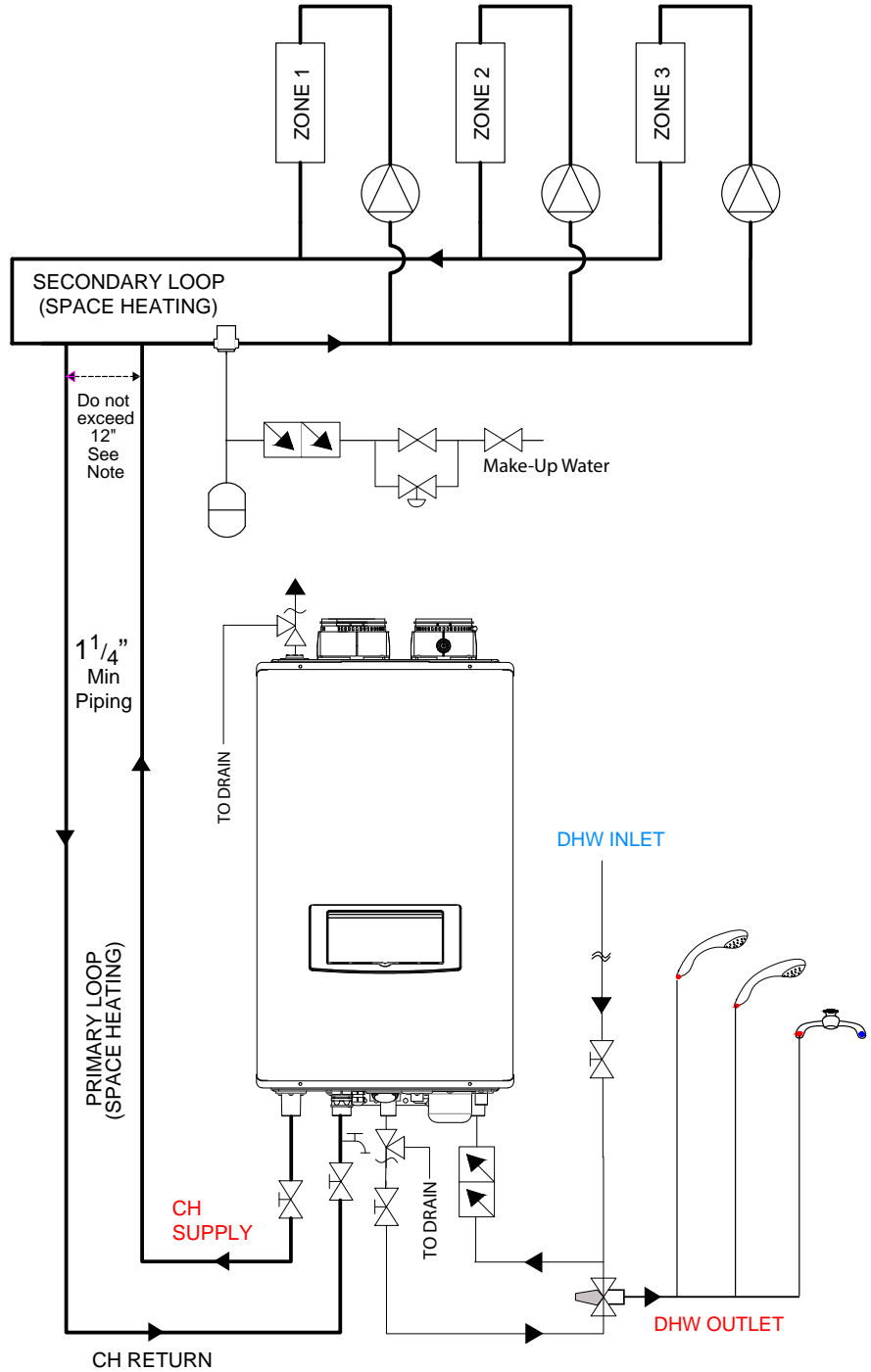
### 4.15 Plumbing Guidelines (continued)

#### 4.15.5 Zoning with circulation pumps

- In a pump based system, each heating zone of has its own circulator pump which runs when the zone demands.
- Each zone thermostat goes to a controller which controls the pumps.

Auto Fill Valve and Backflow Preventer Valves are NOT included (Field Supplied).

	Expansion tank (Diaphragm-type)
	Automatic air vent
	Air separator
	Circulation pump
	Check valve
	Drain valve
	Gate valve
	Backflow preventer
	Pressure Relief Valve
	Anti-scald rated Mixing Valve



1. This piping diagram is meant to show system piping concept only. Installer is responsible for all equipment and detailing required by local codes.
2. All closely spaced tees shall be 12" (or 4 pipe dia) center to center spacing.
3. A minimum of 6 pipe diameters of straight pipe shall be installed upstream and downstream of all closely spaced tees.
4. The minimum pipe size of DHW piping should be 3/4" diameter.
5. Install a minimum of 12 diameters of straight pipe upstream of all circulators.
6. Install a check valve on the return line to the boiler.
7. Manufacturer strongly recommends the use of an anti-scald mixing valve at domestic hot water outlet (boiler location) to reduce potential for scalding. Contact Manufacturer for recommended models. Check with local codes.

## 4.16 Pressure Relief Valve

- External pressure relief valves must be installed. Observe the following. Failure to comply with the guidelines on installing the pressure relief valve and discharge piping can result in personal injury, death or substantial property damage.

### WARNING

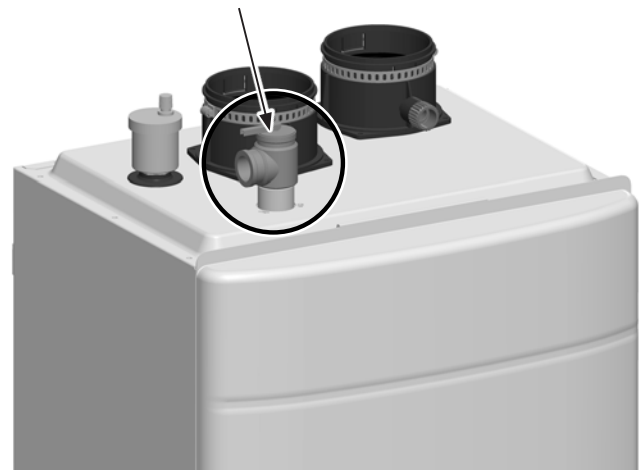
Do not operate this appliance before the pressure relief valve supplied is installed with sufficient relieving capacity in accordance with the ASME Rating Plate on the boiler.

- This hot water boiler is provided with 30 psi safety relief valve that complies with the ANSI/ASME Boiler and Pressure Vessel Code, Section IV ("Heating Boilers). (Model : CASE ACME F-82)
- This safety relief valve (30 psi) is shipped loose for field installation.
- An approved ASME HV Pressure Relief Valve must be installed on the DHW supply line as close to the unit as possible. Valve size 3/4", maximum 150 psi. Not included with boiler.
- For safety, the relief valve(s) must be installed into its designed location and not be removed or plugged. Failure to comply with the guidelines on installing the pressure relief valves and discharge piping can result in personal injury, death or substantial property damage.
- Direct the discharge piping of the pressure relief valve so that hot water will not splash on anyone or any nearby equipment. Attach the discharge line to the pressure relief valve and run the end of the line within 6-12" (150-300mm) of the floor.
- Ensure that the maximum BTU/H rating on the pressure relief valve is equal to or greater than the maximum input BTU/H rating of the combination boiler.
- Pressure Relief Valve must be installed on the CH supply line & DHW outlet line as close to the unit as possible. (CH supply line: maximum 30psi, DHW outlet line : maximum 150psi). No other valves should be placed between the pressure relief valve and the appliance.
- This appliance has a high-temperature shut off switch built in as a standard safety feature .Therefore a "pressure only" relief valve is required.

### WARNING

- DO NOT install a CH pipe line relief valve with a pressure higher than 30psi and DHW pipe line relief valve with a pressure higher than 150psi. This is the maximum allowable relief valve setting for the combination boiler.
- Test the operation of the valve after filling and pressurizing system by lifting the lever. Make sure the valve discharges freely. If the valve fails to operate correctly, replace it with a new relief valve. Ensure that the discharge capacity of the pressure relief valve is equal to or greater than the maximum pressure rating of the combination boiler.

3/4" 30psi Relief Valve



### 4.17 Disposal of Condensate

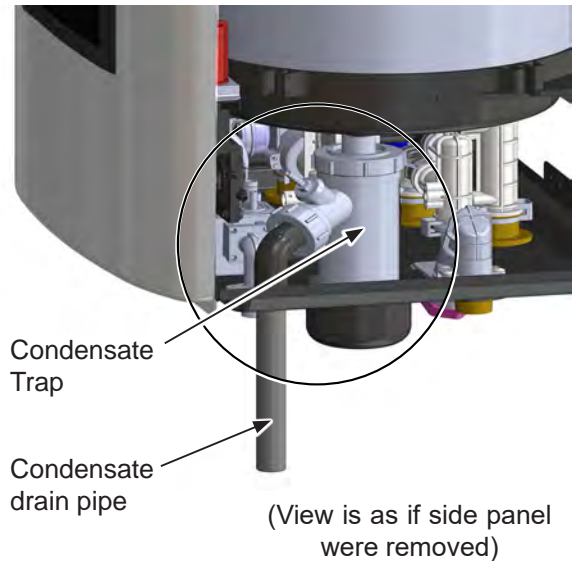
- High efficiency gas condensing Boilers create condensation when operating. Condensation has acidic (pH) of approximately 4-5.
- Condensate must be drained in accordance with all local regulations. Follow your local code with regards to the disposal of condensation.

**One of 4 disposal methods must be followed**

1. to floor drain
2. to neutralizer (optional kit)
3. to laundry tub
4. to condensate pump (field supplied)

- If a neutralizer is installed, periodic replacement of the lime stone (or neutralizing agent) will be required. The rate of depletion of the lime stone varies upon usage of the boiler. During the first year of operation, please check the neutralizer every few months for depletion.

- Apply only corrosion-resistant materials for the condensate drain lines such as 1/2" PVC, CPVC, Polypropylene pipe or included plastic hose.



#### ⚠ NOTICE

Category II & IV water heaters must be installed with a means provided for the drainage of condensate.

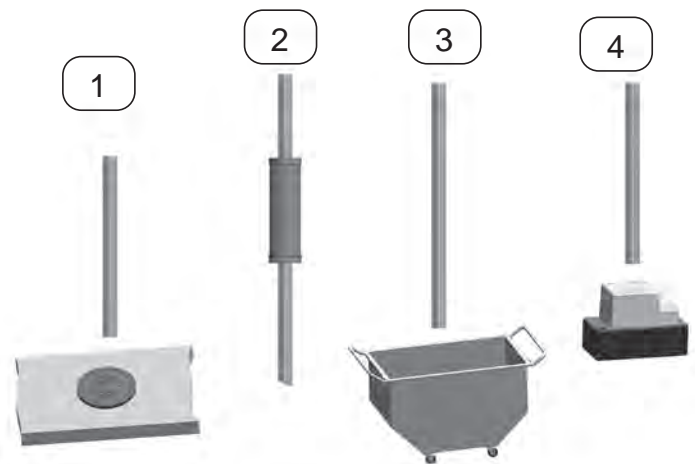
#### ⚠ AVIS

Catégorie II & ; IV chauffe-eau doit être installé avec une moyens prévus pour l'évacuation des condensats.

#### ⚠ CAUTION

Condensate is mildly acidic (pH=5), and may harm some floor drains and/or pipes, particularly those that are metal. Ensure that the drain, drainpipe, and anything that will come in contact with the condensate can withstand the acidity, or neutralize the condensate before disposal. **Damage caused by failure to install a neutralizer kit or to adequately treat condensate will not be the manufacturer's responsibility.**

**Contact Manufacturer to order  
Neutralizer Kit# A2123601**



## 4.18 DHW Flow Restrictors

Flow Restrictors are factory installed. Rated at 3.2 GPM for the model 140 and 7.0 GPM for the model 199, both of these factory installed restrictors are white in color. For the 140, an additional flow restrictor, rated at 4.5 GPM, is blue in color and is packaged with the Product Accessories. See Section 1.

If 3.2 GPM is not sufficient for your model 140 installation, replace the factory installed white flow restrictor with the blue flow restrictor by following these instructions.

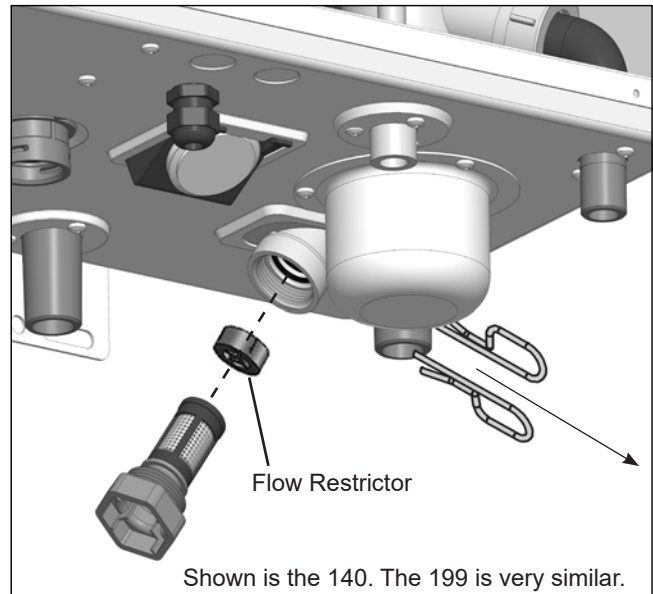
To replace the Flow Restrictor.

1. Being sure that the unit is completely shut off and drained, locate the DHW inlet adapter on the bottom of the appliance.
2. Pull the two pins to release the DHW inlet filter. See Illustration. The flow restrictor is attached to the top of the filter assembly.
3. Remove the installed white flow restrictor and replace it with the blue flow restrictor included with the Product Accessories.
4. Reinstall the DHW inlet filter.
5. Re-insert the two pins.
6. Refill and restart your FT as per the Installation Instructions.

### WARNING

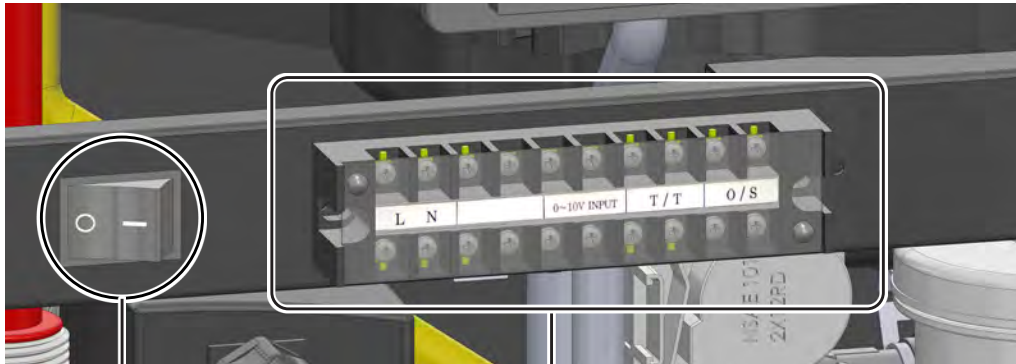
If the appliance has been filled and operational, then the gas, water and power must be completely shut off, and the unit must be drained before proceeding with this instruction. See Section 8 of this installation book.

Failure to do so could result in substantial property damage, sever personal injury, or death.



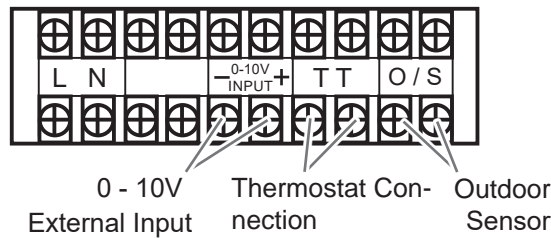
### 4.19 Electrical Wiring Connections

#### FTCW140



Manual Switch

Terminal Block



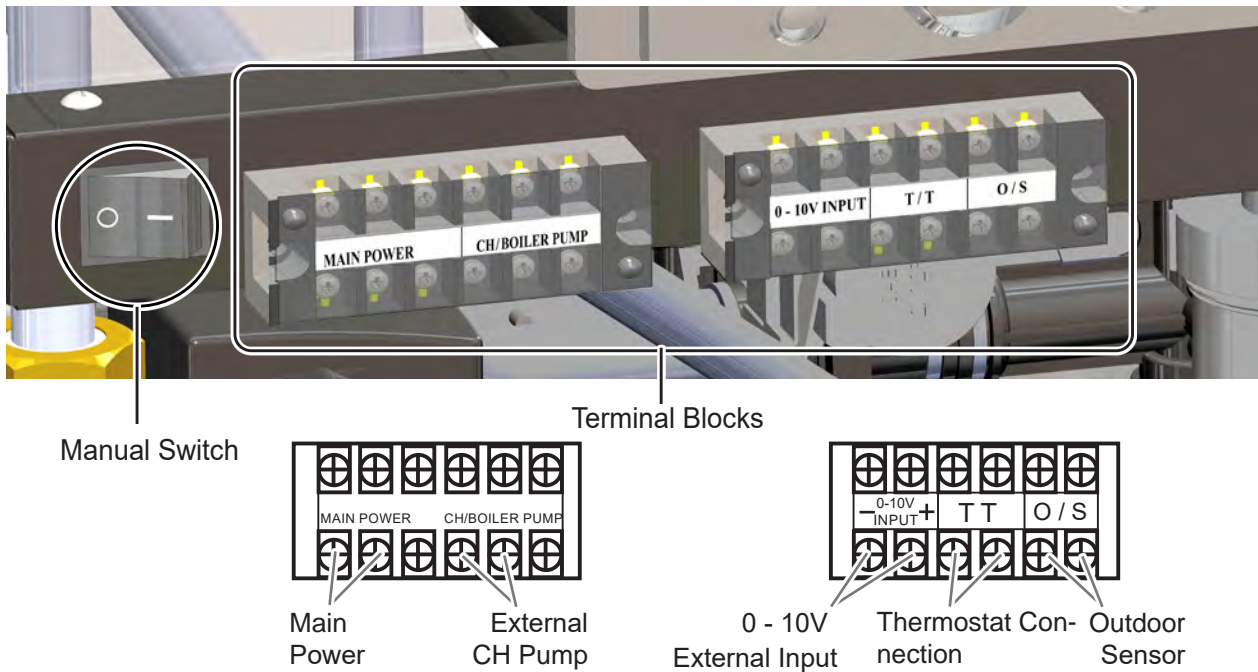
**⚠ WARNING**

- Install wiring and electrically ground boiler in accordance with authority having jurisdiction or, in the absence of such requirements, follow the National Electrical Code, NFPA 70, and/or CSA C22.1 Electrical Code-Part 1 in Canada.
- **ELECTRICAL SHOCK HAZARD** — For your safety, turn off electrical power supply at service entrance panel before making any electrical connections to avoid possible electric shock hazard. Failure to do so can cause severe personal injury or death.

- This appliance must be electrically grounded. Ensure the electrical receptacle that the combination boiler will be plugged into, is properly grounded; if wiring directly.
- Do not attach the ground wire to either the gas or the water piping as plastic pipe or dielectric unions may isolate the Combination boiler electrically.
- The wiring diagrams contained in this manual are for reference purposes only.
- Refer to these diagrams and diagrams from external controls used with this appliance. Read, understand, and follow all wiring instructions.
- Do not disconnect the power supply when the unit is in normal operation. Damage caused by freezing is not covered under the warranty.
- Manual(Rocker) switch maximum allowable current for each circulator is 1.6 amps at 125VAC.  
( Housing : Nylon #66 UL 94V-2 , Rocker : Nylon #66 UL 94V-2, Terminal : Copper Alloy )
- Terminal block (External power connector) : DFT-20A-10P (20 amps at 300VAC)

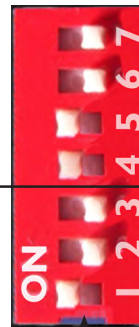
### 4.19 Electrical Wiring Connections (cont)

FTCW199



### 4.20 DIP Switches

ON		OFF	
MIN Fire		Normal Operation	
MAX Fire		Normal Operation	
NG Natural		LP Propane	
3" Vent Size		2" Vent Size	
ON	OFF	ON	ON
ON	OFF	OFF	ON
OFF	ON	ON	ON
MBH 120	<b>140</b>	175	<b>199</b>



Shown is a **Model 140** with 3" Venting and using Natural Gas

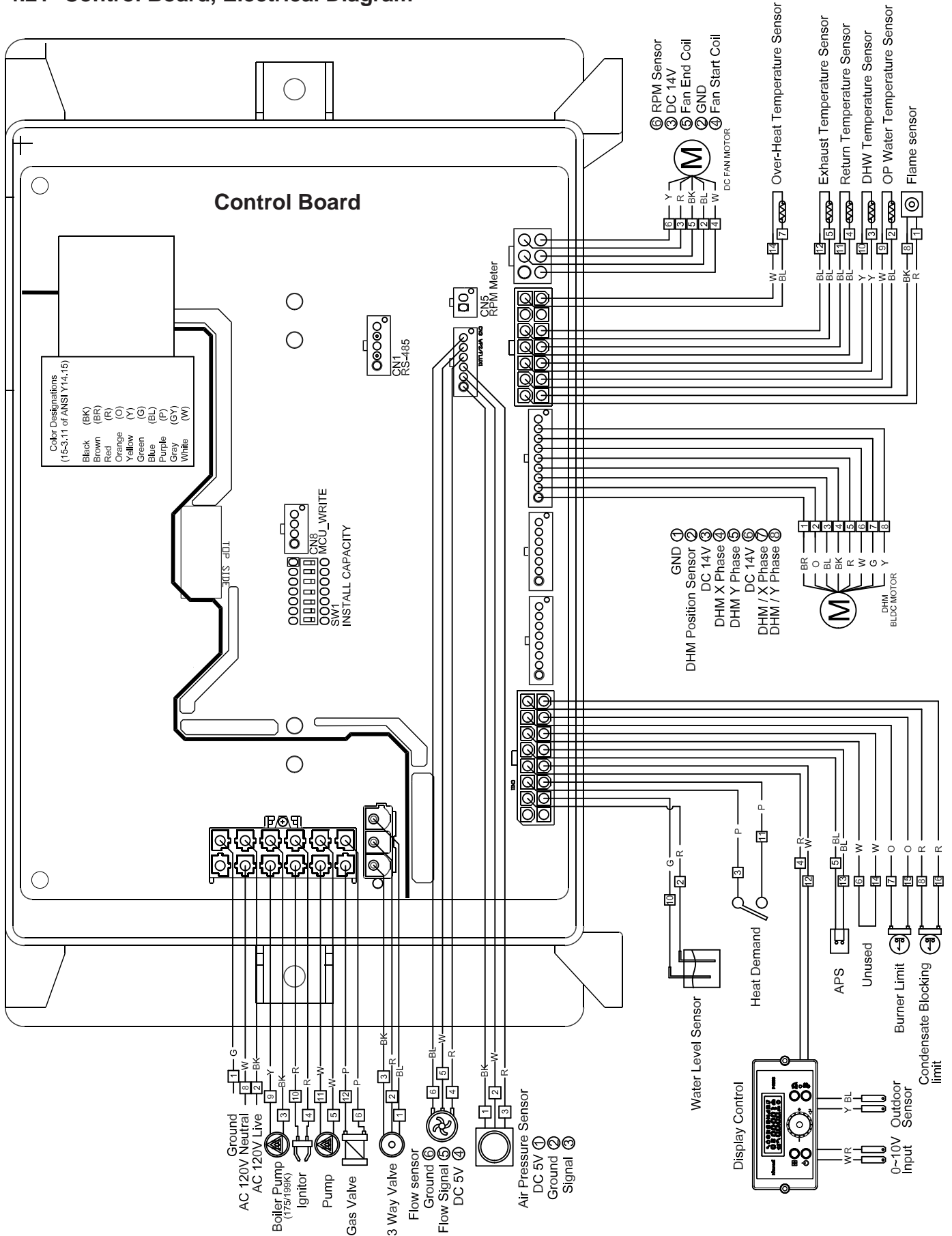


#### System Control Setting

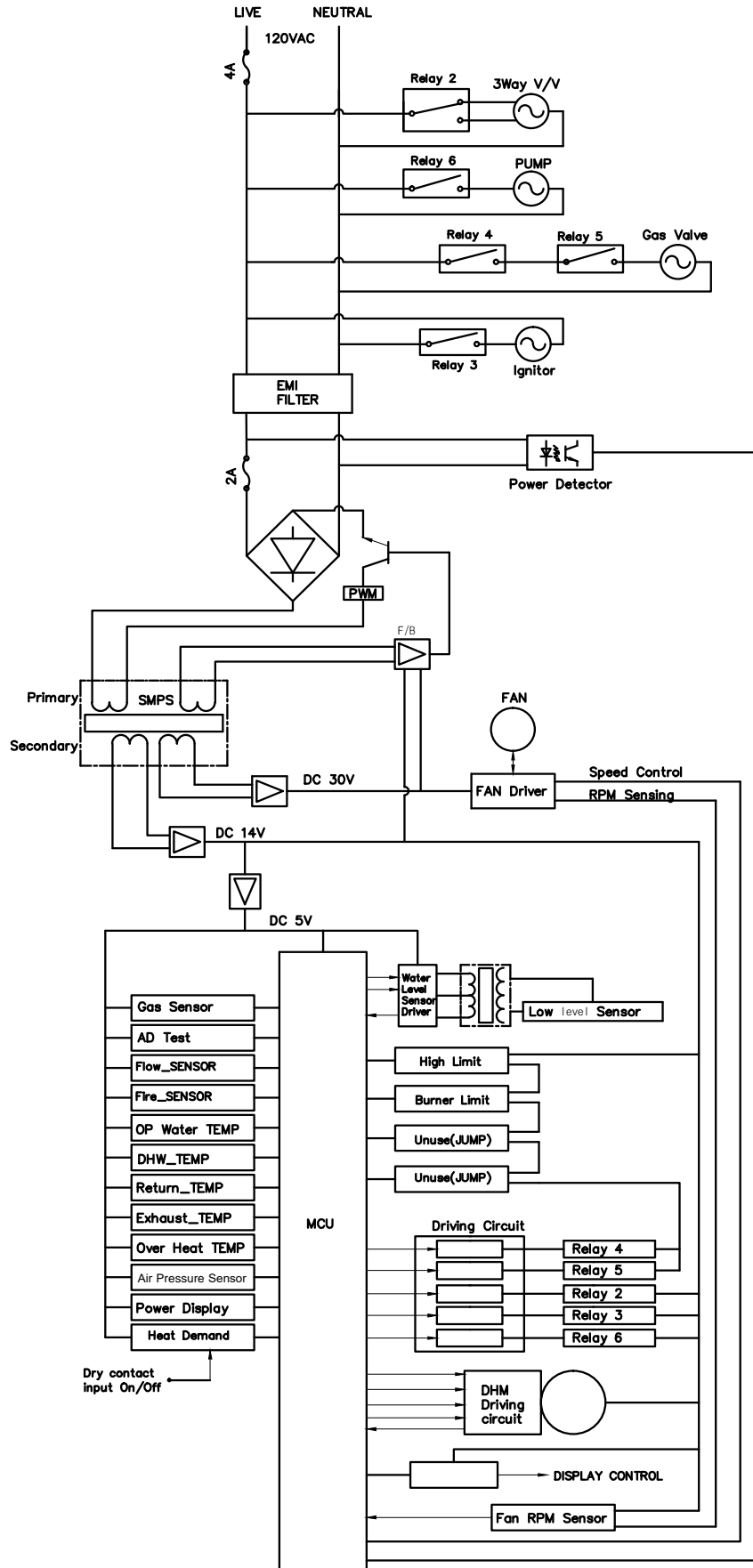
Maximum flame detecting voltage	2.4V
Pre-purge time (Tp)	Maximum 10s, minimum 1s
Safety Time (igniting time) (Ts)	3s
Igniting interval time	10s
Post-purge time (Tip)	120S (1st : 60s + 2nd 60s)
Over-heating 1,2,3 protection detection time	<3s
Pump1 post circulating time (T1pv)	60s
Pump2 post circulating time (T1pv)	60s
High & Low Water Level detection time	<6s
High & Low Water Level Recover time	<6s



### 4.21 Control Board, Electrical Diagram



## 4.22 Ladder Diagram



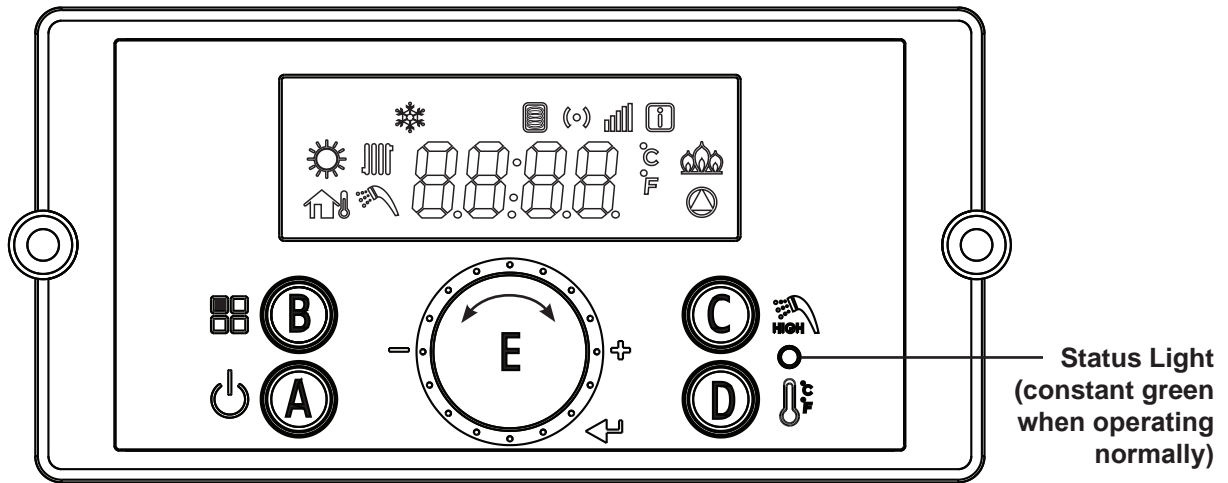
4.23 Electrical Connections

Connector			Description	HT SELV
#, Location, Type	PIN	Label		
CN9 65001WS-12	1	-	GROUND	HT (120V~)
	2	L	Power Supply Line	HT (120V~)
	3	CP1	Not Used	HT (120V~)
	4	IT	Igniter	HT (120V~)
	5	L(HT)	Pump : CH	HT (120V~)
	6	GV	Gas Valve	HT (120V~)
	7	-	-	-
	8	N	Power Supply Neutral	HT (120V~)
	9-12	— N —	AC Power COM Line	HT (120V~)
CN6 LW6A4-03	1	CP3/3Way	3 Way Valve	HT (120V~)
	3		HT (120V~)	
CN1 SMW250-5D	1	RS-485	RS485 +	SELV (5V)
	2		GND	SELV (5V)
	3		RS485 -	SELV (5V)
CN4 LWD1140-06D	1	FAN	Not Used	-
	2		GND	SELV (30V)
	3		VDD	SELV (14V)
	4		Fan power(start coil)	SELV (30V)
	5		Fan power(end coil)	SELV (30V)
	6		Fan speed feedback signal	SELV (14V)
CN8 SMW250-04D	1	MCU ISP	GND	SELV (5V)
	2		ISP /Reset port	SELV (5V)
	3		ISP TOOL0 Data port	SELV (5V)
	4		VCC	SELV (5V)
CN11 LWD1140-16	1	HWL	Not Used	SELV (12V~)
	8			
	2	LWL	Low Water Level Leakage Sensor	SELV (12V~)
	10			
	3	HD	Central Heating Demand	SELV (5V)
	11	TH	Connect to the Display Control(Thermostat)	SELV (14V)
	12			
	4	APS	Jump	SELV (14V)
	13			
	5	EL	Jump	SELV (14V)
	14			
	6	BL	Burner Limit	SELV (14V)
15				
7	HL	Condensate Block	SELV (14V)	
16				

Connector			Description	HT SELV
#, Location, Type	PIN	Label		
CN7 LWD1140-14	1	F.S	Flame Detect Sensor	SELV (5V)
	8			
	2	OP.S	Operating water temperature sensor	SELV (5V)
	9			
	3	DH.S	DHW temperature sensor	SELV (5V)
	10			
	4	I.S	Return temperature sensor	SELV (5V)
	11			
	5	BG.S	Venting (Exhaust) temperature sensor	SELV (5V)
	12			
	6	ST.S	Not Used	SELV (5V)
	13			
	7	SP.S	Over-Heat temperature sensor	SELV (5V)
	14			
CN14 SMW250-09D	1	DHM	GND	SELV (14V)
	2		DHM Stepper motor position	SELV (14V)
	3		VDD	SELV (14V)
	4		DHM Stepper motor coil X phase	SELV (14V)
	5		DHM Stepper motor coil Y phase	SELV (14V)
	6		VDD	SELV (14V)
	7		DHM Stepper motor coil /X phase	SELV (14V)
	8		DHM power IWM Stepper motor coil /Y phase	SELV (14V)
	9		Unuse	-
CN3 SMW250-06D	1	APS SENSOR	VCC	SELV (5V)
	2		GND	SELV (5V)
	3		Voltage Input	SELV (5V)
	4	FLUX1	VCC	SELV (5V)
	5		Water Flow Sensor	SELV (5V)
	6		GND	SELV (5V)
CN5 SMW250-10D	1	RPM	FAN RPM Check	SELV (5V)
	2		GND	SELV (5V)

## SECTION 5 Control Display and Operation

### 5.1 Control Dial and Buttons



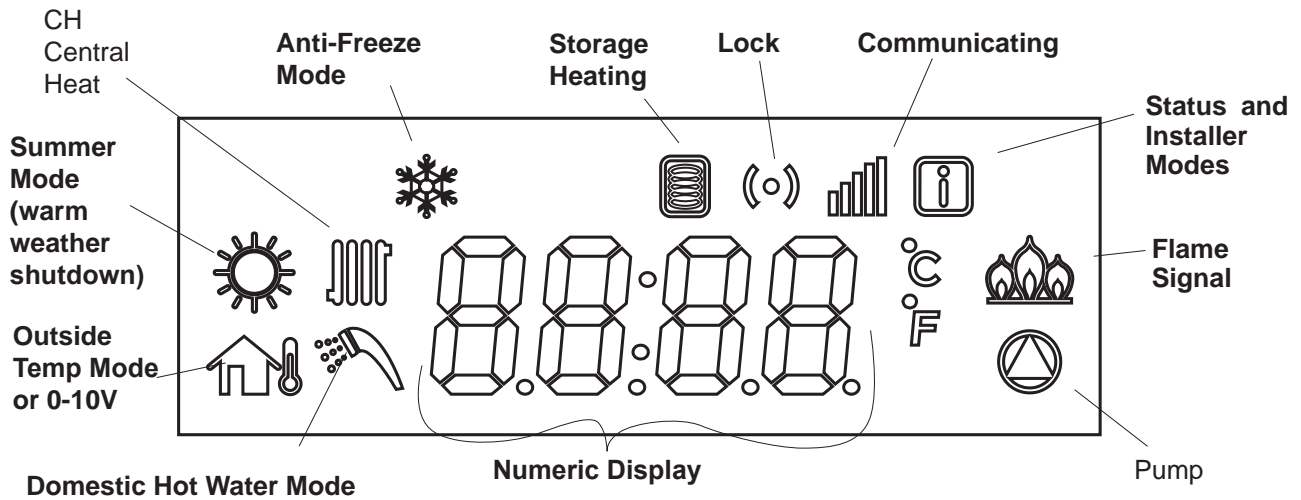
The Control Display

The Control Display has a Control Dial (E), 4 buttons (A, B, C, D), and a Liquid Crystal Display (with 72 back-lit segments). This section of this manual gives instruction on how to navigate into the many functions of the FT and to change temperature set points, set system variables and controller parameters.

Buttons			Function	Method	Function	Method
A		Display Power	Turns Control Display ON/OFF	Press/Tap		
B		Modes	Status Display Mode (With display power on)	Press/Hold (5 Seconds)	Return to Menu (from Status Display Mode)	Press/Tap
			Installer Mode (With display power off)	Press/Hold (5 Seconds)	Return to off display off mode (from installer mode)	Press/Tap
C		Hot Water	DHW Set-Point LOW Range 95 - 120°F (35 - 49°C)	Press/Tap (To return home, tap Scroll/Select)	DHW set-point HIGH Range 121-140°F (49.5-60°C) (from DHW set-point LOW RANGE)	Press/Hold (5 Seconds), (To return home, tap Scroll/Select)
D		Central Heat	CH set-point mode (boiler only)	Press/Tap (To return home, tap Scroll/Select)	Toggle (°C/°F) (from CH setpoint mode)	Press/Hold (5 Seconds)
E		Scroll / Select	Turn to scroll (clockwise or counterclockwise), Tap to select	Press/Tap		

- Temperature Specifications  
 Operating ambient Temperature Range : -10 to 60°C.  
 Operating Relative Humidity up to: 90% at 40°C.  
 Shipping & Storage Temperature Range of : -20 to 80°C.


## 5.2 LCD Overview



CH mode	Central Heat mode icon can be adjusted
Anti-freeze mode	Anti-freeze mode icon
Storage Heating mode	Stored Water Being Heated, can be adjusted
Lock mode	Buttons-locked mode icon
Communication	Communication icon
Summer mode	Only DHW Mode, can be adjusted (warm weather shutdown)
Status and Installer mode	The Status Mode or the Installer Mode is Active (all parameters)
Flame signal	Flame Signal icon
Pump icon	Water pump operation (CH or DHW) icon
Numeric Display	Number and character display, to display all parameters
DHW mode	Combination boiler Set Point, can be adjusted
Outside temp or 0-10 V mode	Operating by outside temperature or 0-10V

The LCD will illuminate when a user action is detected (a button is pressed) and will turn back off after 20 seconds.

\* NOTE: The display will not allow changes when the lock mode ((o)) is activated.


To exit the Lock mode, press the  button.

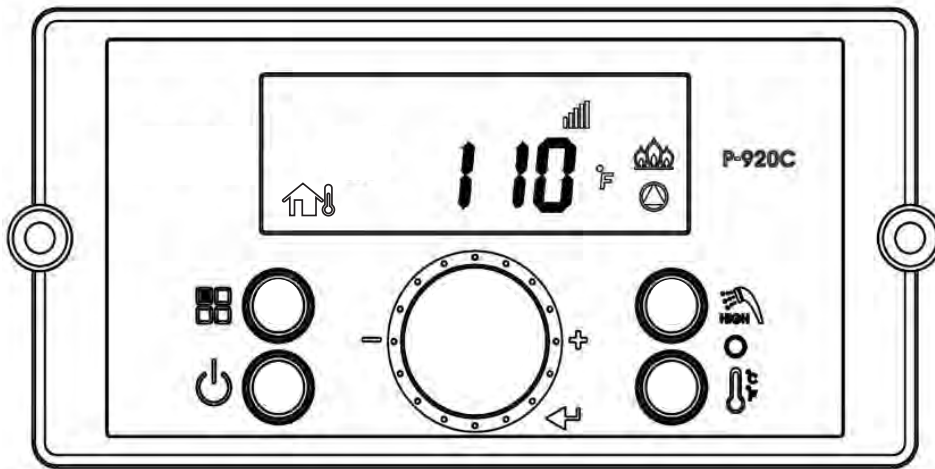
### WARNING





Do not use this appliance if any part has been under water. Immediately call a qualified service technician to inspect the appliance and to replace any part of the control system and any gas control that may have been under water.

### 5.3 Operating Mode

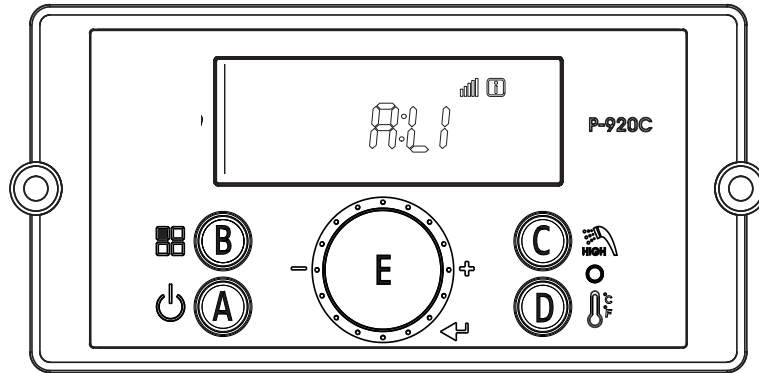
■ Operating Mode









After the Power is turned on, and/or the Control Display is turned on , the Control Display will go through a 'Start Up' checklist and briefly show a sequence of diagnostic codes before entering into the 'Operating Mode'. It will then display the following information.




Indicate	Example
Current Operating Temperature	110°F
Temperature sign Celsius or Fahrenheit letter	°C or °F
Display and Controller are communicating	
If flame detected	
If pump is operating	
Outdoor sensor or 0-10V	

## 5.4 Status Display Mode



Digital Display	Status Display Parameter	Description		
O:ot	Outdoor temperature	Current Outdoor temperature		
A: Li or A: GA	Flow unit	Current flow value(Li: L/m, GA: GPM)		
b: It	CH Return Water Temperature	Current Return Water Sensor Temperature		
C: Fr	Fan rpm	Current fan rpm value		
d: Lc	Lock mode	Lock mode ON/OFF		
E: oP	OP temperature	Current OP temperature		
F: dH	DHW temperature	Current DHW temperature		
H: Eh	Exhaust temperature	Current Exhaust temperature		
I : St	N/A	Not Used (Default is 0)		
J: oH	Overheat temperature	Current Overheat temperature		
L: rt	1: PH	Supply power time	Supply power time x 100 hour	
	2: rh	Burner operation time	Burner operation time x 1 hour	
	3: rH	Burner operation time	Burner operation time x 1,000 hour	
	4: It	Ignition cycles	Ignition cycles x 10 times	
	5: IH	Ignition cycles	Ignition cycles x 10,000 times	
P: Ou	Displays output condition for internal primary pump and three way valve.  - Off  - On	1st Icon	2nd Icon	3rd Icon
		Not Used	Internal CH Pump	3 Way Valve
				
				

### To change any of the above listed Status Parameters,

Press and Hold Button B  to get into the Status Display Mode.

Rotate Dial E until you find the Parameter that you wish to change. Tap Dial E to enter that Parameter.

Adjust to the setting that you require and then press (tap) Dial E to save and to Exit.




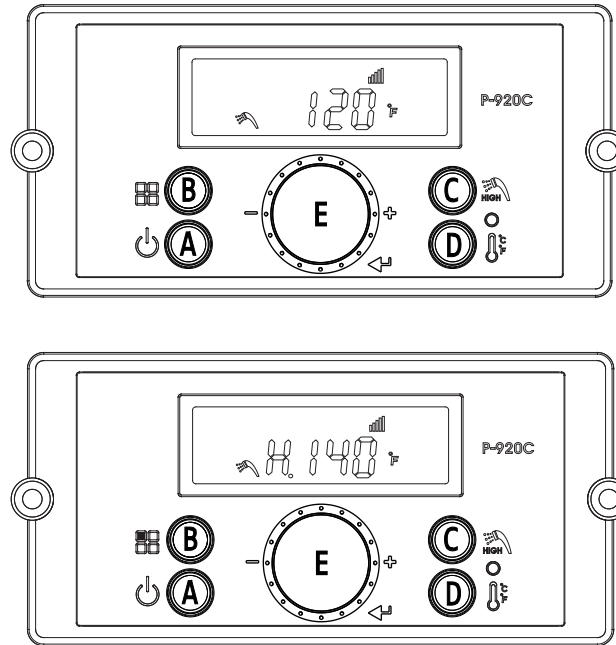
### 5.5 DHW Set Point Change Mode



■ DHW Set Point Change Modes

The display shows the following information when changing water heating temperature set points.

Changing between Celsius and Fahrenheit

When the button D  is pressed (for more than 5 seconds), temperature unit will toggle between °C and °F.



Indicate	Example
Current DHW set-point temperature	120°F
Temperature sign Celsius or Fahrenheit letter	°C or °F
If display is communicating with the main controller normally, the communication icon will be indicated.	
When DHW set-point range is high : from 121°F (49.5°C) to 140°F (60.0°C)	H . 140°F
When changing DHW setpoint, the DHW icon will flash	

\* Default DHW set-point is 120°F (49°C)

• **DHW 95-120°F (35 - 49°C) LOW range (Default)**

-To change **LOW range**, press the C Button. The DHW icon and current DHW LOW will flash (a flashing value means it can be changed).

- Turn dial E clockwise to increase and counterclockwise to decrease until desired temperature is reached.
- Press dial E to save setpoint changes.

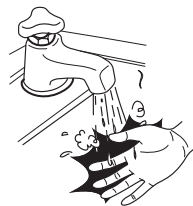
• **DHW 121 - 140°F (49.5 - 60°C) HIGH range**

-To change **HIGH range**, press and **HOLD** the C button for more than 5 seconds. The DHW icon and current DHW HIGH will flash (a flashing value means it can be changed).

- Turn dial E clockwise to increase and counterclockwise to decrease until desired temperature is reached.
- Press dial E to save setpoint changes and to Exit.

**⚠ DANGER**


Scalding may occur within 5 seconds at a setting of 140°F (60°C). Water temperatures over 125°F can cause severe burns, or death from scalding. Children, disabled, and elderly are at highest risk of being scalded. Read all instructions before setting temperature at appliance. Feel water before bathing or showering.

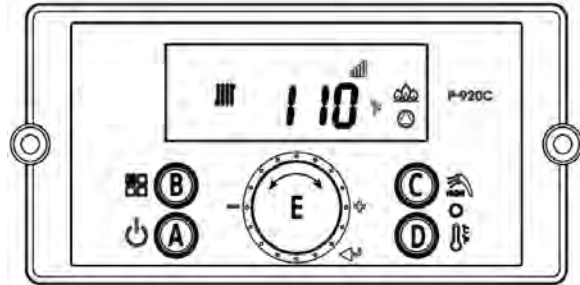






**Manufacturer strongly recommends the use of an anti-scald mixing valve at domestic hot water outlet (boiler location) to reduce potential for scalding. Contact Manufacturer for recommended models. Check with local codes.**

## 5.6 CH Set Point Change Mode


Changing between Celsius and Fahrenheit

When the button D  is pressed (for more than 5 seconds), temperature unit will toggle between °C and °F.



Indicate	Example
Current Operating Temperature	110°F
Temperature sign Celsius or Fahrenheit letter	°C or °F
Display and Controller are communicating	
If flame detected	
If pump is operating	
When changing CH Setpoint, the CH Icon will flash	

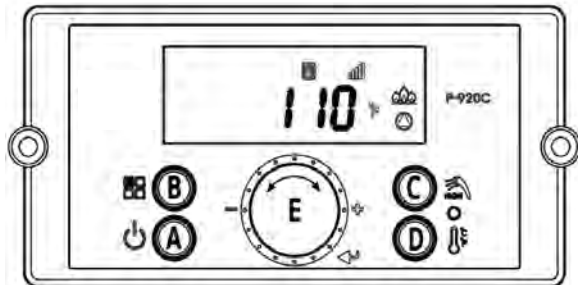
Default CH set-point is 120°F (49°C)  
 CH set-point range is 86 - 180°F (30.0 ~ 82.0°C)





**To change CH Setpoint**, press the D  button. The CH Icon and current CH Setpoint will flash.

Turn the E dial clockwise to increase, and counterclockwise to decrease CH setpoint, until desired temperature is reached.

Press E dial to save changes and to Exit.

## 5.7 Storage Mode



Indicate	Example
Current Operating Temperature	110°F
Temperature sign Celsius or Fahrenheit letter	°C or °F
Display and Controller are communicating	
If flame detected	
Storage mode indication	
If Pump is operating	

**To change Storage Mode Temp**, First turn OFF the power to the Control Display.

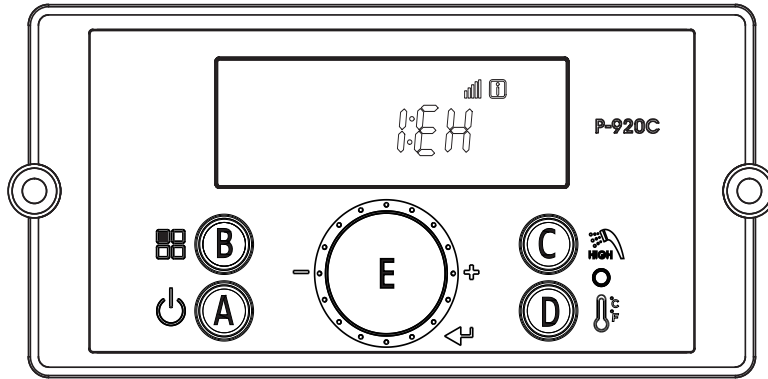
Then Press and Hold Button B  to get into the Installer Mode.

Rotate Dial E until you find **5:St** Tap Dial E to enter Storage Mode. Storage Mode indicates that the boiler is heating the water held in the internal storage tank. When Storage Mode is active, the display will appear as shown.

Turn the E dial clockwise to increase, and counterclockwise to decrease setting.


Press E dial to save changes and to Exit.

### 5.8 Installer Parameters



These changes are to be made only by a qualified technician.

**To change any of the Installer Parameters,** Start by turning **OFF** the Power  to the Display Control.

Then, with the power OFF, Press and HOLD (more than 5 seconds) the Button B  to get into the Installer Mode.

Rotate Dial E until you find the Installer Parameter (full list on facing page) that you wish to change. Tap Dial E to enter that Parameter.

Adjust to the setting that you require and then press (tap) Dial E to save and to Exit.

Finish by pressing button B 

## 5.8 Installer Parameters


Index	Parameter	Description
<b>1: EH</b>	History entry	History fault code (E0~E9)
<b>2: cE</b>	Clear Error History	Clearing of error History buffer
<b>3: In</b>	System initialize	System initialize to default
<b>4: Fu</b>	Flow unit	gallon / liter
<b>5: St</b>	Heat storage function	Heat storage function On/Off
<b>6: OH</b>	Maximum Outdoor Temperature	Range: (Minimum Outdoor Temperature + 9°F) to 110°F Default 68°F (20°C)
<b>7: OL</b>	Minimum Outdoor Temperature	Range: -4°F to (Maximum Outdoor Temperature -9°F)
<b>8: FH</b>	Max fan	Adjusts Maximum Fan Speed Range: -30 - +30
<b>9: FL</b>	Min fan	Adjusts Minimum Fan Speed Range: -30 -+30
<b>10: dr</b>	Delete running time	Delete running time
<b>11: dl</b>	Delete igniting times	Delete igniting times
<b>12: bt</b>	Outside Unit Function Delay Time (boost time)	When heating in the outside unit function for the first time, there will be a delay. (0~120 min, Default 0)
<b>13: Ft</b>	Delay time for heating burner operation	Burner does not operate during the delay time when the burner is turned off due to the temperature during heating operation. (0~20 min, Default 1 min)
<b>14: bo</b>	Setting temperature of burner ON.	Heating temperature setting during heating operation – Operate in burner ON temperature setting Range: -12.7°C(9°F)~-2.7°C(27°F), Default 2.7°C(27°F)
<b>15: OF</b>	Warm Weather Shutdown	This warm weather temperature setting will shut down CH Mode 10°C(50°F)~43°C(110°F), Default 38°C (100°F)
<b>16:cH</b>	Setting for Heating Maximum Temperature	Range: 9°F less than Minimum Temperature to 180°F, Default 180F 12.7°C less than Minimum Temperature to 82°C, Default 82°C
<b>17:cL</b>	Setting for Heating Minimum Temperature	Range: 86°F to 9 degrees °F less than Maximum Temperature, Default 86°F 30°C to 12.7degrees °C less than Maximum Temperature, Default 30°C
<b>18:dH</b>	Setting for Hot Water Maximum Temperature	49°C(120°F)~60°C(140°F), Default 60°C(140°F)
<b>19:cb</b>	Heating Combustion Rate	50%~100%, Default 100%
<b>20:db</b>	Hot Water Combustion Rate	50%~100%, Default 100%
<b>21:PP</b>	Pump Post-Purge Time	(Heating Pump) 1min ~ 60min, Default 40min
<b>22:Po</b>	Pump on Time	(Heating Pump Repeat ON Time) 1 min ~60 min, Default 5 min
<b>23:PF</b>	Pump off Time	(Heating Pump Repeat Off Time) 0min ~60 min, Default 10 min
<b>24:SF</b>	Heat storage off Temperature	60°C(140°F)~75°C(167°F),Default(70°C)158°F
<b>25:So</b>	Heat storage on Temperature.	(off Temperature-Setting Temperature) -12.7°C(9°F)~-2.2°C(36°F), Default (-2.7°C) 27°F
<b>26:dt</b>	Delay time when switching from DHW mode to CH mode	Range: 0 – 2 minutes,Default 2min
<b>27:PE</b>	Internal CH Pump Post-Purge Time, T/T Satisfied	Allows the user to set the appliance pump post purge time once the appliance CH setpoint and thermostat are satisfied. Range: 1-5 minutes,Default 1min
<b>28: HA</b>	High Altitude setting	(Normal)0<1<2<4 (High)
<b>29: AP</b>	Internal CH Pump and 3-way valve Pump Test Mode	This function sets the time to run both the Internal CH and 3-way valve pumps to purge air from the system. Range: 1 – 30 minutes ,Default 5min
	Internal CH Pump and 3-way valve Pump Test Mode	Turn this function on to activate Internal CH and 3-way valve pump testing. Only works in installation mode. Turns off when in normal mode. Default OFF
<b>30: dP</b>	DHW Timeout Feature	Range: 0~12 time, '0' OFF, Default: 4 time

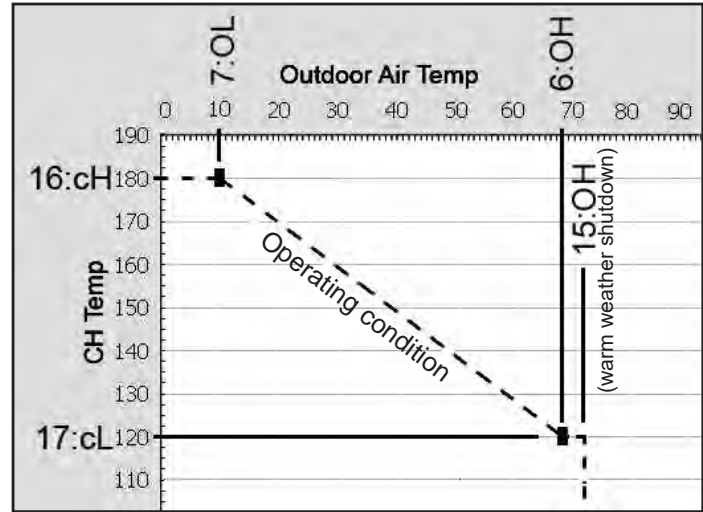
### 5.9 Outdoor Reset Adjustment

Outdoor Reset varies the control setpoint based on the outdoor temperature. The reset function works as shown in Figure 'CH Outdoor Reset'. When the outdoor air temperature reaches 6:OH "high outdoor temperature setpoint", the control point setting is adjusted to 17:cL "low boiler temperature setpoint". When the outdoor air temperature reaches 7:OL "low outdoor temperature setpoint" the control setpoint is adjusted to 16:cH "high boiler temperature".

Default outdoor reset setpoint is 100°F (38°C)

The Outdoor Temperature Mode Icon on the display will flash if an Outdoor Sensor or 0-10 Volt is not connected to the appliance.

To check the CH Target Temperature while using Outdoor Temperature Mode, press the  button while the appliance is operational and the display panel is powered on.



CH Outdoor Reset

Connect to terminal strip as outlined 4.17 Electrical Connections.

**NOTE: 0 - 10VDC terminals may not be used for both outdoor reset and 0 - 10VDC temp setpoint simultaneously.**

### 5.10 External Set Point Temperature Control

A signal from a building management system may be connected to the appliance to enable remote control. This signal should be a 0-10 volt DC signal. When this input is enabled, a building control system can be used to control the set point temperature of the appliance.

The control interprets the 0-10 volt signal as follows; when the signal is between 0 and 1.5 volts, the appliance will be in standby mode, not firing.

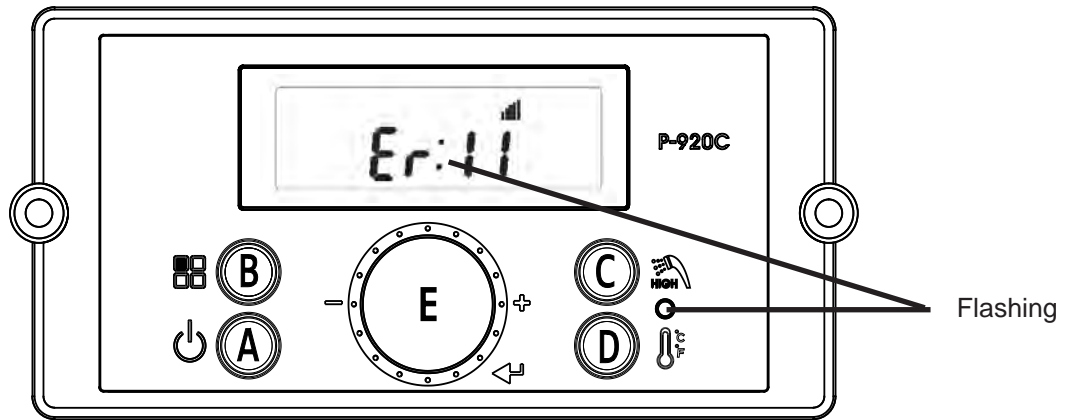
When the signal rises above 1.5 volts, the appliance will ignite. As the signal continues to rise towards its maximum of 10 volts, the appliance will increase in set point temperature. Adjust 16:cH and 17:cL to set MIN and MAX boiler water temperatures respectively.


Connect a building management system or other auxiliary control signal to the terminals marked for this purpose on the appliance terminal block (shown in Piping Diagrams, this manual). Caution should be used to ensure that the 0-10 VOLT + connection does not become connected to ground.


Connect to terminal strip as outlined 4.17 Electrical Connections.

**NOTE: 0 - 10VDC terminals may not be used for both outdoor reset and 0 - 10VDC temp setpoint simultaneously.**

### 5.11 Error Mode



Indicate	Example
Error ' Er : ' will flash	Er:11
Error Code	Er:11
Display and Controller are communicating	

NOTE: When communication between the Control Display and the main controller is lost, the  will not be displayed.

## SECTION 6 Error Codes

### 6.1 Error Code Tables

Error Code	Error Code Description	Possible Remedies	Recover methods
10	Flame has Extinguished 8 (Eight) Times	<p>Press the Power button to clear the Error Code.</p> <p>If Error happens again:</p> <ol style="list-style-type: none"> <li>1. Monitor the gas pressure to the appliance while in operation. Ensure pressure is between 3.5" to 10.5" WC (Nat. Gas) and 8" to 13" WC (Propane).</li> <li>2. Check gas valve wire. Ensure connection is secure.</li> <li>3. Check flame detection sensor. Ensure connections are secure. Normal operating settings are more than 2.5DC before ignition, less than 2.5DC after ignition.</li> <li>4. Check vent terminations. Ensure there are no blockages.</li> <li>5. Assure that the flame is stable when lit.</li> <li>6. If the problem persists, replace the main control.</li> </ol>	Hard Lock
11	Ignition has Failed 10 (Ten) Times	<p>Press the Power button to clear the Error Code.</p> <p>If Error happens again:</p> <ol style="list-style-type: none"> <li>1. Monitor the gas pressure to the appliance while in operation. Ensure pressure is between 3.5" to 10.5" WC (Nat. Gas) and 8" to 13" WC (Propane).</li> <li>2. Check gas valve wire. Ensure connection is secure.</li> <li>3. Check flame detection sensor. Ensure connections are secure. Normal operating settings are more than 2.5DC before ignition, less than 2.5DC after ignition.</li> <li>4. Check igniter transformer for proper connection.</li> <li>5. Clean the spark igniter with steel wool to remove oxides. Ensure proper separation (3-4 mm).</li> <li>6. Replace the spark igniter if damaged.</li> <li>7. Assure that the flame is stable when lit.</li> <li>8. If the problem persists, replace the main control.</li> </ol>	Hard Lock
16	Operating Temperature Sensor detects Water Temperature Greater than 203°F (95°C)	<p>Press the Power button to clear the Error Code.</p> <p>If Error happens again:</p> <ol style="list-style-type: none"> <li>1. Check if dip switch Max Fire setting is ON. Switches 6 and 7 should be OFF for normal operation.</li> <li>2. Check if CH inlet pipe is blocked. Ensure there is enough water flowing to the appliance.</li> <li>3. Check Operating Temperature sensor at CH heat exchanger outlet. If resistance is zero, replace the sensor.</li> <li>4. If the problem persists, replace the main control</li> </ol>	Hard Lock
20	Condensate – Closed is Normal, Open is Fault (Condensate Drain Trap)	<p>Press the Power button to clear the Error Code.</p> <ol style="list-style-type: none"> <li>1. Check Condensate and main controller connections. Ensure all are secure.</li> <li>2. Check Condensate sensor resistance. If resistance is zero, replace the switch.</li> <li>3. Check Condensate hose. Ensure it is connected and in good condition.</li> <li>4. Check condensate line and termination for blockages.</li> <li>5. Check Vent Pipe for blockages.</li> <li>6. If the problem persists, replace the main control.</li> </ol>	Hard Lock
28	Overheat Sensor Open or Short	<p>This Error Code will go away when CH temperature decreases.</p> <p>If Error happens again:</p> <ol style="list-style-type: none"> <li>1. Check overheat temperature sensor. Ensure connections are secure.</li> <li>2. Check overheat sensor resistance. If resistance is zero, replace the sensor.</li> <li>3. If the problem persists, replace the main control.</li> </ol>	Soft Lock
32	DHW Sensor Open or Short	<p>This Error Code will go away when outlet DHW temperature decreases.</p> <p>If Error happens again:</p> <ol style="list-style-type: none"> <li>1. Check DHW outlet temperature sensor. Ensure connections are secure.</li> <li>2. Check sensor resistance. If resistance is zero, replace the sensor.</li> <li>3. If the problem persists, replace the main control.</li> </ol>	Soft Lock
33	CH Temperature Sensor Open or Short	<p>This Error Code will go away when CH temperature decreases.</p> <p>If Error happens again:</p> <ol style="list-style-type: none"> <li>1. Check CH temperature sensor. Ensure connections are secure.</li> <li>2. Check CH sensor resistance. If resistance is zero, replace the sensor.</li> <li>3. If the problem persists, replace the main control.</li> </ol>	Soft Lock

Error Code	Error Code Description	Possible Remedies	Recover methods
35	Venting (Exhaust) Sensor Open or Short	This Error Code will go away when exhaust temperature decreases. If Error happens again: 1. Check Venting (exhaust) temperature sensor. Ensure connections are secure. 2. Check sensor resistance. If resistance is zero, replace the sensor. 3. Check vent pipes for blockage. 4. If the problem persists, replace the main control	Soft Lock
36	Abnormal Supply Voltage	Supply voltage is too low to operate. This Error Code will go away when supply voltage returns to normal operating range. If Error happens again: 1. Ensure appliance is properly wired to a power source meeting the requirements on the rating plate. 2. If problem persists, replace the main control	Soft Lock
37	Abnormal Supply Frequency	Supply frequency is too high to operate. This Error Code will go away when supply frequency returns to normal operating range. If Error happens again: 1. Ensure appliance is properly wired to a power source meeting the requirements on the rating plate. 2. If problem persists, replace the main control.	Soft Lock
38	Error Appears When Control Stores Data, but Data is not Saved	Press the Power button to clear the Error Code. Replace the main control.	Hard Lock
40	Gas Leakage is Detected for Greater than 5 seconds, or three times within 10 minutes	IMPORTANT: If you smell gas, STOP! Follow the instructions on page 2, this manual, and call a qualified service technician or the fuel gas utility. Press the Power button to clear the Error Code. If Error happens again: 1. Check the appliance cover. Ensure it is secure. 2. Check gas connections for leakage with a soapy solution. Fix any leaks. 3. Check condition of the burner assembly. 4. If the problem persists, replace the main control.	Hard Lock
41	Fan Speed too High with Flame On	Press the Power button to clear the Error Code. If Error happens again: 1. Check the vent connections for blockages. 2. Check the burner assembly. 3. Check fan operation. If fan appears to be operating normally but RPMs are too high, replace the fan. 4. If the problem persists, replace the main control.	Hard Lock
42	LWCO Jumper disconnected	Press the Power button to clear the Error Code. If Error happens again: 1. Ensure the LWCO jumper wire is properly connected. 2. If the problem persists, replace the main control.	Soft Lock
43	Burner Overheat Switch Open	Press the Power button to clear the Error Code. If Error happens again: 1. Check burner overheat switch connections. Ensure connections are secure. 2. Check switch resistance. If resistance is zero, replace the switch. 3. If the problem persists, replace the main control.	Hard Lock
44	Air Pressure Sensor (APS) Fault	Press the power button to reset If error happens again: 1. Check the vent pipe for blockages. 2. Check the vent pipe for blockages. 3. If error do not clear, replace the APS 4. If the problem persists, replace the main control.	Hard Lock
45	Air Pressure Sensor (APS) Open	Check the aps connection. 1.If APS is closed and connections are secure, check APS connection. 2. If the problem is not happen, replace the APS 3. If the problem persists, replace the main control.	Soft Lock
61	Fan Speed Feedback Signal Abnormal	This Error Code will go away when the condition is remedied. If Error happens again: 1. Check the connections to the fan. Ensure all are secure. 2. If the fan does not rotate during the ignition sequence, check for AC8V~26.5V power at the fan connection. If AC8V~26.5V power is present at the control, replace the fan. If the blower does not have AC8V~26.5V power, check power at the control. If AC8V~26.5V power is not present at the control, replace the control. 3. If the problem persists, replace the main control.	Soft Lock

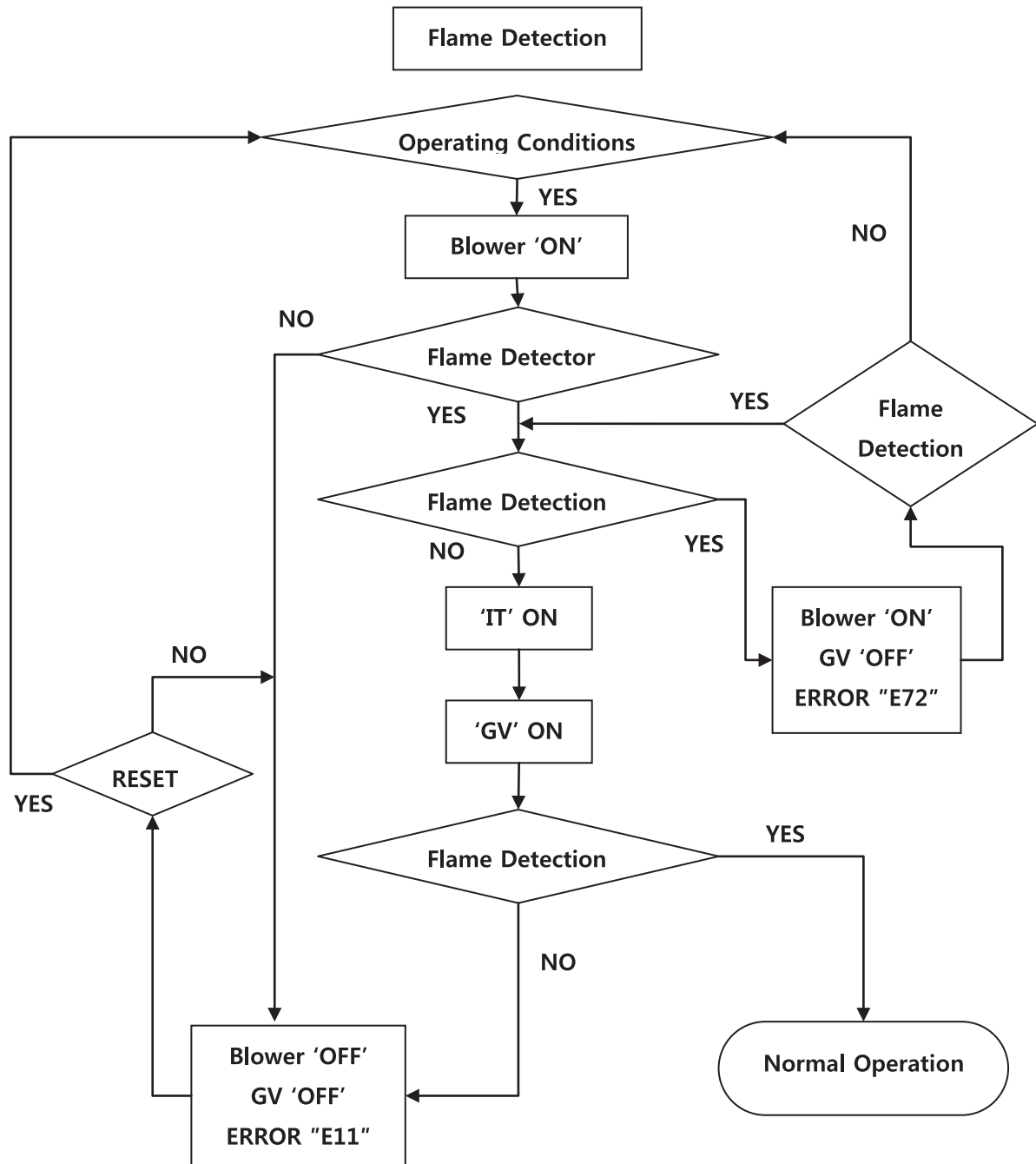


**SECTION 6. Error Codes (continued)**

Error Code	Error Code Description	Possible Remedies	Recover methods
66	Mixing Valve Initial Value Error (Mixing Valve Cannot Return to Initial Position)	This Error Code will go away when the condition is remedied. If Error happens again: 1. Turn power OFF and ON at the main power switch internal to the appliance. 2. Check wiring connections to mixing valve. Ensure all are secure. 3. Replace mixing valve. 4. If the problem persists, replace the main control.	Soft Lock
68	Mixing Valve Operation Error (Mixing Valve Stuck in Initial Position)	This Error Code will go away when the condition is remedied. If Error happens again: 1. Turn power OFF and ON at the main power switch internal to the appliance. 2. Check wiring connections to mixing valve. Ensure all are secure. 3. Replace mixing valve. 4. If the problem persists, replace the main control.	Soft Lock
70	Register, Ram, Rom, I/O Port, AD Abnormal, Important EPROM Data or Safe Data Abnormal	This Error Code will go away when the condition is remedied. If Error happens again: 1. Turn power OFF and ON at the main power switch internal to the appliance. 2. If the problem persists, replace the main control.	Soft Lock
72	Flame Signal Detected before Ignition	This Error Code will go away when the condition is remedied. If Error happens again: 1. Check the appliance cover. Ensure it is secure. Flame detection sensor can detect an external light source. 2. Check flame detection sensor. Ensure connections are secure. Normal operating settings are more than 2.5DC before ignition, less than 2.5DC after ignition. 3. If the problem persists, replace the main control.	Soft Lock
76	Poor Communication	This Error Code will go away when the condition is remedied. If Error happens again: 1. Check connections from main control to display panel. 2. If the problem persists, replace the display and/or the main control.	Soft Lock
80	Low Water Level Sensor (Low Water Level Detected Four (4) Consecutive times)	This Error Code will go away when the condition is remedied. If Error happens again: 1. Ensure all valves are open to the appliance and there are no leaks. 2. Ensure all air has been purged from the system. 3. Check wiring connections to low water level sensor. Ensure all are secure. 4. Check low water level sensor resistance. If resistance is zero, replace the sensor. 5. If the problem persists, replace the main control.	Soft Lock
81	Low Water Level Circuit	This Error Code will go away when the condition is remedied. If Error happens again: 1. Ensure all valves are open to the appliance and there are no leaks. 2. Check wiring connections to low water level sensor. Ensure all are secure. 3. Check low water level sensor resistance. If resistance is zero, replace the sensor. 4. If the problem persists, replace the main control.	Soft Lock
85	Freeze Protection (Appliance has detected water temperature below 34°F(1°C))	This Error Code will go away when the freezing condition is remedied. If Error happens again: 1. Ensure appliance is located in a mechanical room protected from freezing conditions. 2. Ensure all valves are open to the appliance, there are no leaks. 3. Check wiring connections to low water level sensor. Ensure all are secure. 4. Check low water level sensor resistance. If resistance is zero, replace the sensor. 4. If the problem persists, replace the main control.	Soft Lock
94	Exhaust Sensor detects Vent Temperature is Greater than 190oF (88oC)	This Error Code will go away when the condition is remedied. If Error happens again: 1. Check if dip switch Max Fire setting is ON. Switches 6 and 7 should be OFF for normal operation. 2. Check exhaust temperature sensor. Ensure connections are secure. 3. Check sensor resistance. If resistance is zero, replace the sensor. 4. Check exhaust vent for blockage. 5. If the problem persists, replace the control. 6. If the problem persists, replace the heat exchanger.	Soft Lock

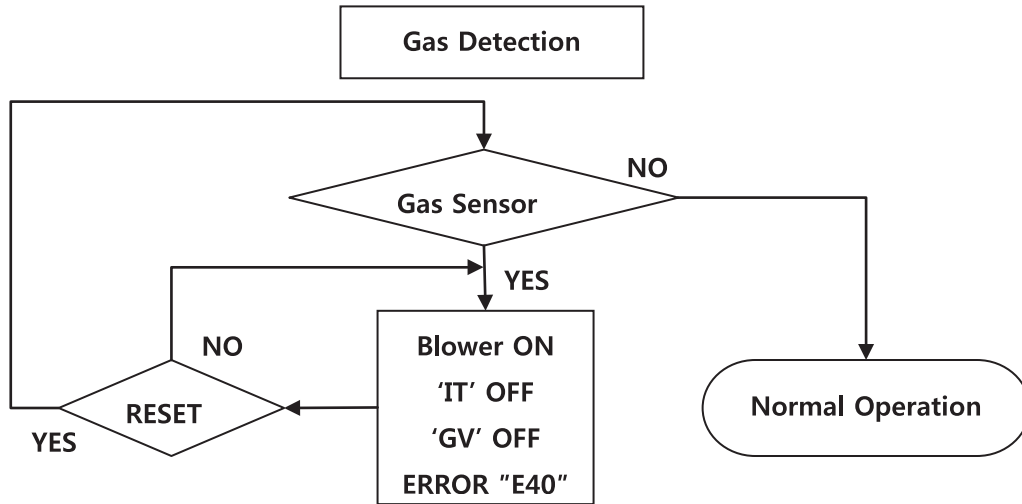
## 6.2 Fault Tree Analysis

### 1. Flame detection

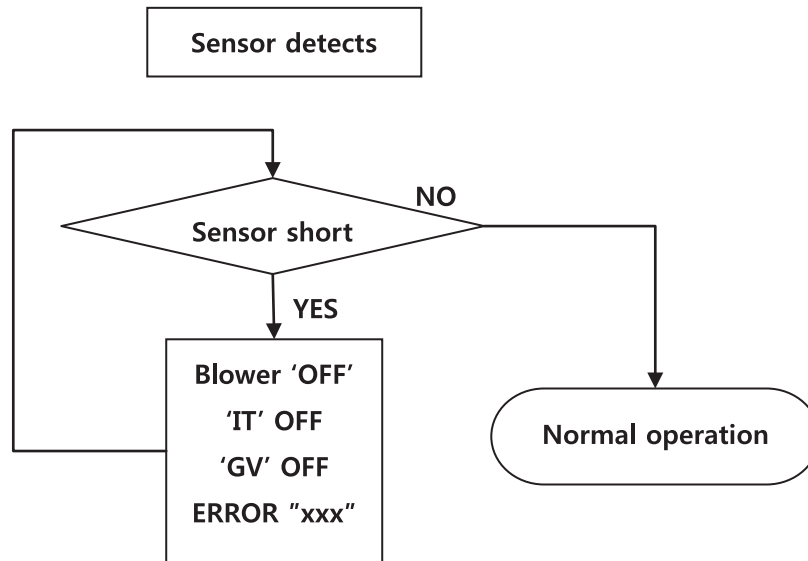


6.2 Fault Tree Analysis (cont)

2. Gas Detection



3. 'Storage', 'DHW', 'OP', 'CH overheat', 'Exhaust heat' Sensor detects



Error code	contents
E32	DHW NTC open or short
E33	OP NTC open or short
E35	Exhaust NTC open or short

## SECTION 7 Troubleshooting

### 7.1 Diagnostics

Question	Answer
Burner does not ignite when the hot water is opened.	Make sure that the ON/OFF button on the Control Panel has been turned ON.
	If the monitor on the Control Panel is blank, make sure the power cord is plugged and 4A fuses on the main controller in the units are good.
	Make sure that there is water supplied to the unit. The unit activates once the inlet water flow is over 0 gpm.
	Make sure the cold and hot water lines are not plumbed in reverse side.
	Make sure that the cold water and gas supply lines are opened.
	Make sure that the water lines are not frozen.
Water is not hot enough.	Check that the setting temperature on the unit is not too low
	Make sure that the filter in the cold water supply line is not clogged with debris.
	Make sure that the gas supply type is correct.
	Check the supply and manifold gas pressures are in accordance with specifications.
	Make sure that the water flow sensor with three wires has been properly connected on the top of heat exchanger.
Water is too hot.	Make sure that the setting temperature on the unit is not too hot.
	Make sure that the filter in the cold water supply line is not clogged with debris.
	Make sure that the gas supply type is correct.
Hot water temperature fluctuates at the opened tap.	Make sure that the filter in the cold water supply line is clean.
	Make sure that the gas supply type is correct.
	Check the supply gas pressure is sufficient.
The blower is still operating after the combustion stops.	This is normal because the blower keeps operating for 1 minute to vent (exhaust) the flue gas from the chamber once the combustion has stopped.
Temperature Rise too Quickly	Occurs when supply water temperature in heat exchanger rises faster than 2°F per second during the first two minutes the burner is on. Automatically resets after a few minute delay or using manual reset on control panel. See message displayed TEMPERATURE SENSOR and follow procedure for loose connections.
Abnormal sounds come from unit during operation.	A leak of combustion gas between sealed chamber and exhaust tube inside the unit. Call a qualified service technician for evaluation.
	Improper venting termination, make sure that the venting termination complies with specification.
	Check the supply gas pressure is sufficient. Insufficient gas pressure will cause unstable burner flame and noise.
Heater doesn't fire when DHW flow is initiated	Potentially the domestic water flow is too low. Min allowable is 0.75 gpm. Check in Manual Mode OTO AGA
CH Temp drops lower than expected before unit re-fires	Change Parameter 14:bo to 10degrees F (5.5 degrees C)

## 7.2 Suggested Corrective Actions

This controller is able to record information about the boiler's condition at the time of the five previous faults or errors. Refer to the Section '5.10 Error Mode' of this manual.

Display	Condition	Diagnostic	Corrective Action(s)
Nothing shown on display control panel and blower running at full speed.	Control is not receiving power.	Check wiring for short circuit or incorrect wiring.	Correct wiring per wiring diagram including connection of transformer to the control.
		Check transformer connection to the control per wiring diagram. Check for 12V output of transformer.	Replace transformer if it is receiving 120V, but not outputting 12Vac.
Nothing is shown in display control panel and no other boiler components are operating.	Control is not receiving 120V power.	Check service switch and/or circuit breaker to boiler turned is on.	Turn on service switch to power boiler.
		Is there 120 Volts at the service switch?	Troubleshoot and correct the power supply to the manual switch.
		Is the ON/OFF POWER SWITCH (inside boiler case) turned on?	Turn ON the manual power switch inside the boiler case.
		Check for 120 volts at the line voltage terminal block located inside the boiler case.	Correct wiring inside the boiler case using the wiring diagram in this manual.
		Inspect the fuse. Replace if necessary.	Replace the fuse with proper part found in the replacement part section of this manual. If fuse blows again recheck wiring per diagram.
Nothing is shown on control panel, but boiler is operating.	Occurs when the communication is lost from the control to the display.	Check for loose connections and proper pin alignment/engagement on the Control's plug.	Check for continuity on the wire harness from the display to the control. See repair parts section for proper replacement part.
		Cycle power off and on using boiler power switch and check for operation.	Replace with new display module. See repair parts section for proper replacement part.

Fault	Condition	Diagnostic	Corrective Action(s)
TEMPERATURE SENSOR	Occurs when a temperature sensor has electrically shorted (SHORT) or has become disconnected (OPEN).	Reset using manual reset screen on control panel. (Power button)	Check all the temperature readings of the boiler on the DIAGNOSTICS - TEMPERATURES menu to determine if any sensors are currently displayed as SHORT or OPEN.
			Check wire harness for loose connections and pin engagement at sensor Connection and Control module.
			If problem persists after checking items above replace Control. Refer to repair parts section for kit number.
FLAME FAULT	Occurs when flame is detected when there should be no flame.	Reset using manual reset screen on control panel. (Power button)	Burner may be operating too hot due to incorrect combustion. Inspect flame and conduct combustion test.
			Check for flame at burner via flame current with burner off. Turn boiler off and watch flame through observation port. If flame continues after shutdown replace gas valve.
BLOWER FAULT	Blower unable to reach required speed or does not reach 0 RPM when turned off.	Reset using manual reset screen on control panel. (Power button)	Check wire harness for loose connections and pin engagement at blower. Connections.
			Boiler in standby mode and blower not running. If BLOWER SPEED is not 0 RPM then replace blower.
			If blower does not rotate during ignition sequence check for 120V power at blower connection. If 120Vac power at blower motor and it doesn't start replace blower. Check power at Control. If 120Vac is not present at Control when boiler is powered replace Control.
IGNITION FAULT	Even if boiler went through 8 ignitron attempts, but cannot detect flame	Power off and on.	Dirty burner and/or heat exchanger will cause high back pressure and poor ignition. Visual inspection of flue ways often will not be able to diagnose condition.
			Check incoming gas pressure with boiler off and at Max fire. Adjust within limits on rating label.
			Check for flue pipe and intake pipe restrictions or blockage
			Check burner fasteners and gaskets
			Check air intake pipe and proper propane orifice
GAS VALVE FAULT	The Control has detected a problem with it gas valve output circuit.	Reset using manual reset screen on control panel. (Power button)	Check wire harness connections between gas valve and Control.
			If lockout re-occurs replace Control.

## SECTION 8 Maintenance

### 8.1 Annual startup & general maintenance

■ Regular Maintenance

- This Manual should be placed in a safe and dry location near the Combination boiler. Maintenance instructions should be carried out by the following guidelines.

■ Maintenance procedures [ Daily ]

**- Check that the boiler casing is closed.**

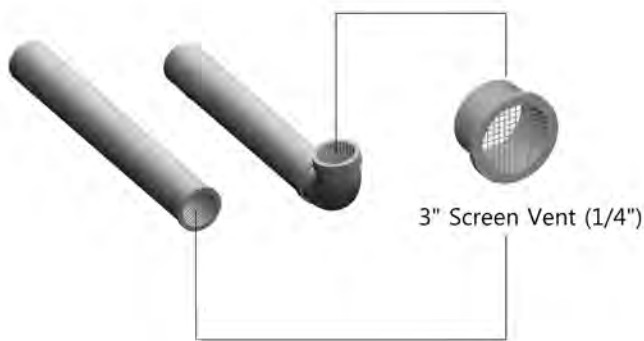
Check if there is any problem with the Combination boiler casing and the two upper and lower screws are tightened well. Combination boiler casing must be closed while it is running.

**! WARNING**

To prevent potential severe personal injury, death or substantial property damage, remove all contaminated materials. If contaminants are found: Remove products immediately from the area. In order to check the status of Combination boiler, call a qualified service technician to inspect the combination boiler for possible damage from acid corrosion.

**! WARNING**

DO NOT store combustible materials, gasoline or any other flammable vapors or liquids near the water heater. Remove them immediately or store them other places.



**- Check the power source.**

Make sure that the power cord is correctly connected. The main power line is connected to the manual switch box inside a combination boiler. (Power line through the strain relief in the bottom of the combination boiler casing and fix it.)

**- Check the status of the control panel**

Check status of the power supply. Please check for any debris on the button.

■ Maintenance procedures [ Monthly ]

**- Check the vent pipe.**

Visually inspect the flue gas vent piping for detecting any signs of blockage, leakage or deterioration of the piping. Please contact a qualified service technician immediately if you find any problem.

**- Check the air inlet pipe.**

Visually inspect the air inlet to be sure it is unobstructed. Inspect entire length of air piping for ensuring that piping is intact and all joints are properly sealed. Call your qualified service technician if you notice any problems.

**- Check the relief valve.**

Inspect the Combination boiler relief valve and the relief valve discharge pipe for any signs of weeping or leakage. If the relief valve often weeps, immediately contact your qualified service technician for inspecting the Combination boiler and system.

**- Check the condensate outlet.**

While the Combination boiler is running, check the discharge end of the condensate drain tubing. Make sure that no flue gas is escaping from the condensate drain tubing.

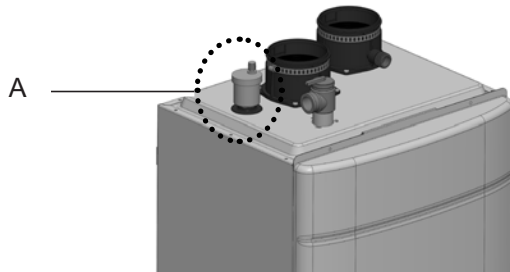
If flue gas is continuously escaping, it is a serious problem. Call your qualified service technician for inspecting the Combination boiler and condensate line. Also, refill the condensate trap if problem persists regularly.

**- Check the vent terminal screen vent (rodent screen).**

If you encounter a problem of combustion specifications, visually inspect the terminal screen. And then replace it with spare parts or clean the screens.

**- Check the air vent**

If the air vent valve seems to work freely without leaking, replace cap "A" by twisting all the way on. Loosen cap "A" one turn to allow vent to operate. If vent does not operate correctly, replace the vent.



seat. If the valve continues to weep, contact your qualified service technician for inspecting the valve and system. If water does not flow from the valve even though you have lifted the lever completely, the valve or discharge line may be blocked. Shut down the Combination boiler immediately. Call your qualified service technician to inspect the combination boiler and system.

**- Check the burner state**

You can clean the exterior of burner. However, if you need to clean the inside of the burner stage, you should call a qualified service technician.

■ Maintenance procedures [Every 6 Months]

**- Check the boiler piping (gas and water)**

Visually inspect for leaks around internal water piping. Also inspect external water piping, circulators, relief valve and fittings. Immediately call a qualified service technician to repair any leaks. Leaks must be fixed by a qualified service technician immediately.

Failure to comply with this instruction could result in severe personal injury, death or substantial property damage.

**- Check the pressure relief valve**

**! WARNING**

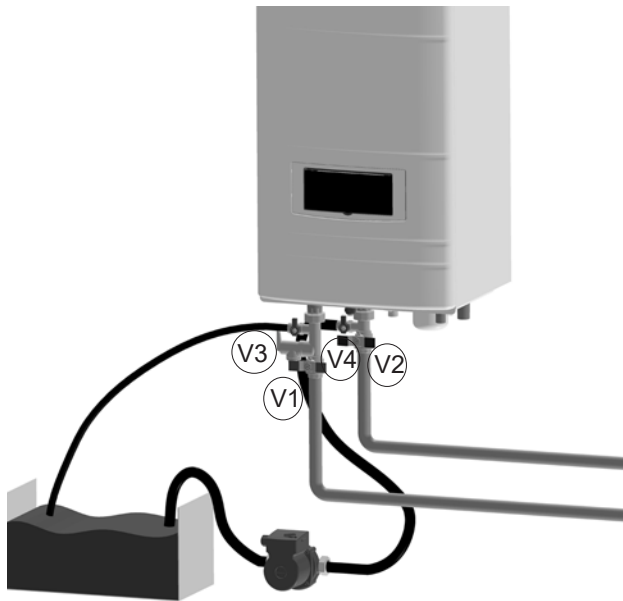
Leaks must be fixed by a qualified service technician immediately. Failure to comply with this instruction could result in severe personal injury, death or substantial property damage. This discharge line must be installed by a qualified heating installer or a service technician.

Before proceeding, verify that relief valve outlet has been piped to a safe place of discharge, avoiding any possibility of scalding from hot water. If water flows freely, release the lever and allow the valve to seat. Watch the end of the relief valve discharge pipe to ensure that the valve does not weep after the line has had time to drain. If the valve weeps, lift the seat again to attempt to clean the valve



## 8.2 Flushing the Combination Boiler

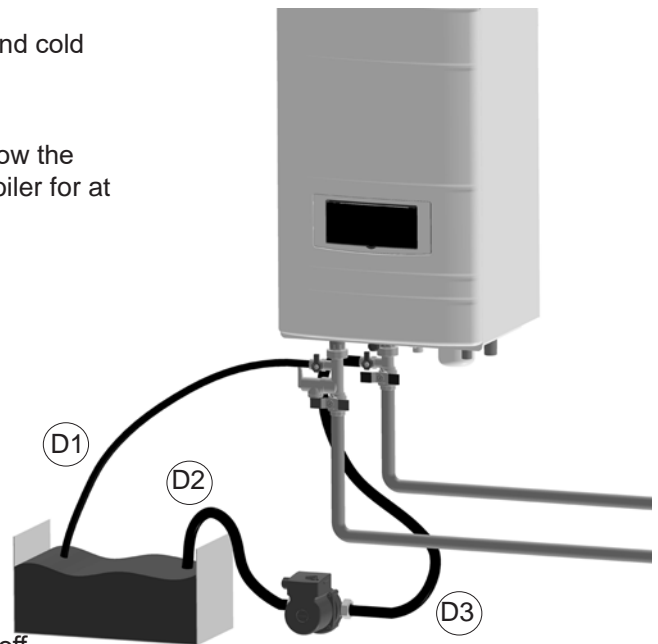
Flushing the Heat Exchanger is a complicated procedure that should only be done by an authorized technician or licensed professional. Keep in mind that improper maintenance can void your warranty.



1. Disconnect electric power to the combination boiler.
2. Close the shutoff valves on both hot water outlet and cold water inlet lines. (V1 & V2)
3. Connect hose "D1" to the valve "V3" and place the free end in the bucket. Connect hose "D3" to the circulation pump outlet and the cold water inlet line at the valve "V4". Connect hose "D2" to the circulation pump inlet and place the free end in the bucket.

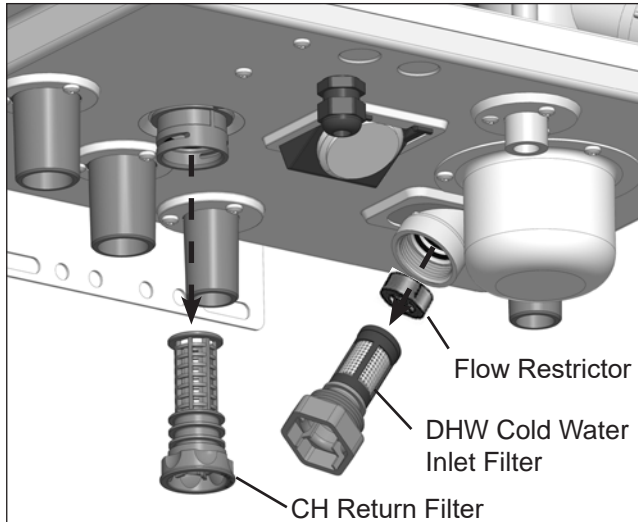
4. Pour the cleaning solution into the bucket. Place the drain hose (D1) and the hose (D2) to the pump inlet into the cleaning solution.
5. Open service valves (V3 & V4) on the hot water outlet and cold water inlet lines.
6. Turn on the circulation pump (Operate the pump and allow the cleaning solution to circulate through the combination boiler for at least 1 hour at a rate of 4 gallons per minute.)

7. Rinse the cleaning solution from the combination boiler as follows:
  - Remove the free end of the drain hose (D1) from the bucket.
  - Close service valve, (V4), and open shut off valve, (V2).  
Do not open shut off valve, (V1).
  - Allow water to flow through the combination boiler for 5 minutes.
  - Close shut off valve (V2).

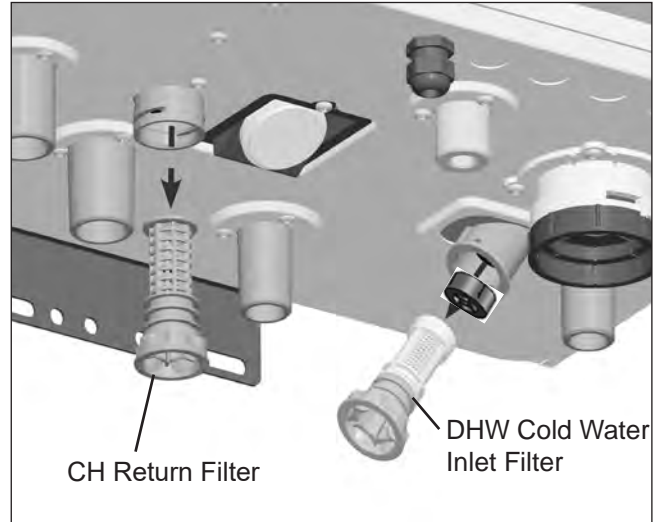


8. Ensure service valves are closed (V3 and V4) and shut off valves are open (V1 and V2).
9. Disconnect all hoses.
10. Remove the cold water inlet filter from the combination boiler and clean out any residues.
11. Reinsert the filter and ensure the filter cap is securely tightened.
12. Connect electrical power to the combination boiler.

### 8.3 Draining and Cleaning



FTCW140



FTCW199

1. Place a bucket under the appliance to collect the residual water inside the combination boiler.
2. Press the Power button on the front control panel to turn OFF the electrical power to the combination boiler.
3. Turn off the gas valve.
4. Close water supply valve on the inlet to the appliance. If there is no valve, turn off main water valve.
5. Open the hot water faucets completely.
6. Remove the CH (Central Heat) return filter by removing the metal pin and then pulling the filter downward.
7. Remove the Cold Water Inlet filter by removing the two small pins and then pulling the filter downward at an angle. If your system is using a flow restrictor, be sure that the flow restrictor is also cleaned and placed back into the system during re-assembly.
8. Clean them with a toothbrush and clean running water.
9. To refill the combination boiler, reassemble the filters back into the combination boiler and reverse steps 7 back to 1.



### 8.4 Freeze Protection

FT Series Boilers are certified for indoor use only, and are not design-certified for placement outdoors. Proper precautions for freeze protection are recommended for boiler installations in areas where the danger of freezing exists.

Power outage, interruption of gas supply, failure of system components, activation of safety devices, etc., may prevent a boiler from firing. **Any time a boiler is subjected to freezing conditions, and the boiler is not able to fire, and/or the water is not able to circulate, there is a risk of freezing in the boiler or in the pipes in the system.** When water freezes, it expands which may result in bursting of pipes, or damage to the boiler, which could result in leaking or flooding conditions.

#### ⚠ NOTICE

Different glycol products may provide varying degrees of protection. Glycol products must be maintained properly in a heating system, or they may become ineffective. Consult the glycol specifications, or the glycol manufacturer, for information about specific products, maintenance of solutions, and set up according to your particular conditions.

#### ⚠ NOTICE

Not all pumps are capable of maintaining the reduced temperature rise required with glycol concentrations greater than 35%.

**Freeze Protection (continued)**



Do NOT use automotive antifreeze or ethylene glycol. Use only inhibited propylene glycol solutions which are specially formulated for hydronic systems. Ethylene glycol is toxic and can attack gaskets, seals, and metallic components used in hydronic systems. A correct glycol concentration and inhibitor level is critical.

Some items to consider are

- Consider the effects of reduced heat transfer and an increase in head pressure against the system circulator. For example: A 30% mixture of glycol will result in a BTU output loss of 15% with a 5% increase in head against the system circulator.
- Glycol mixtures should not exceed 50%. A 50% mixture of glycol will result in a BTU output loss of 30% with a 50% increase in head against the system circulator.
- The glycol solution should be tested as recommended by the glycol manufacturer but not less than annually. Some items of concern are pH additive breakdown, inhibitor reduction, etc.
- Glycol/antifreeze solutions expand more than water; therefore, system design must take this into account. For example: a 50% by volume solution expands 4.8% in volume for a temperature increase from 32°F to 180°F, while water expands 3% over the same temperature rise.

**CAUTION**

It is highly recommended to follow the manufacturers recommended concentrations, expansion requirements, and maintenance recommendations. You must carefully calculate the additional friction loss in the system as well as the reduction in the heat transfer coefficients.

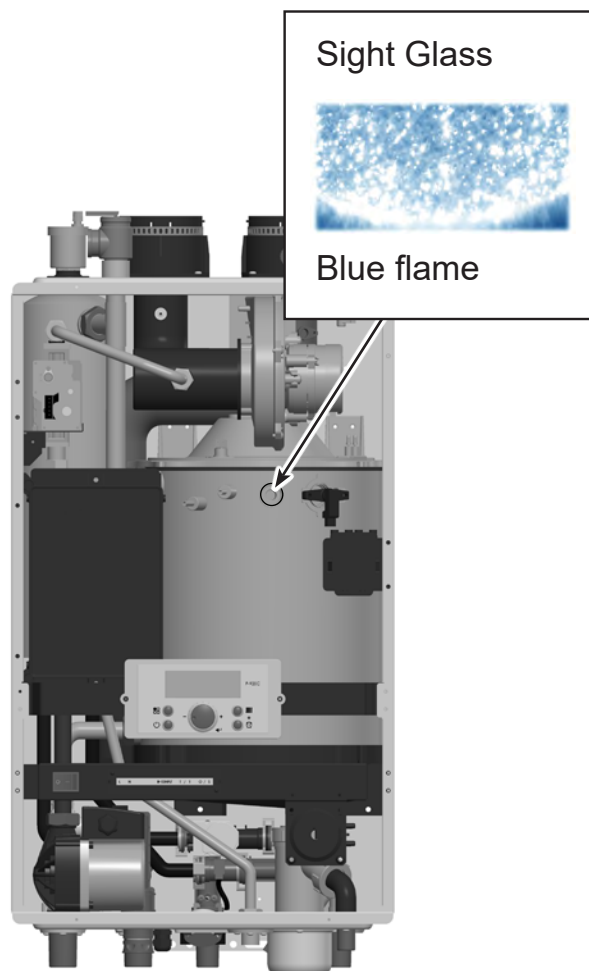
**SECTION 9 Installation Check**

**9.1 Quick View**

- Before Installing
  - Make sure that there is enough space for installing Water and gas line.
    - Verify vent/air termination is located as required.
  - All models need for propane Conversion which requires a separate gas conversion manual.
- Install Water Piping
  - Boiler loop piping must be sized to the minimums listed in the Boiler manual. Using smaller piping will cause performance problems.(page 34)
- Install Vent & Air Piping
  - Slide the air inlet pipe and vent pipe into the Boiler pipe connector.
  - Make sure the terminations are placed as required in the manual and that air intakes are at least 12 inches above normal snow line.
  - Refer to the material check list in this guide for a list of items needed.
- Install Condensate Piping / Tubing & Components
  - Fill out the material check list in this guide to ensure you have the tubing or PVC pipe and all components needed for the condensate piping.
  - Connect internal components that are supplied with the Boiler.
- Install Gas Piping
  - Install a union and shutoff valve.
- Wire the Boiler
  - Connect power wiring and control wiring per boiler manual wiring diagram.(Section 4.19)
- Start up, Adjust & Test
  - Follow the Boiler manual instructions to clean the system if needed, then fill and check water chemistry.

## 9.2 Final Check Lists

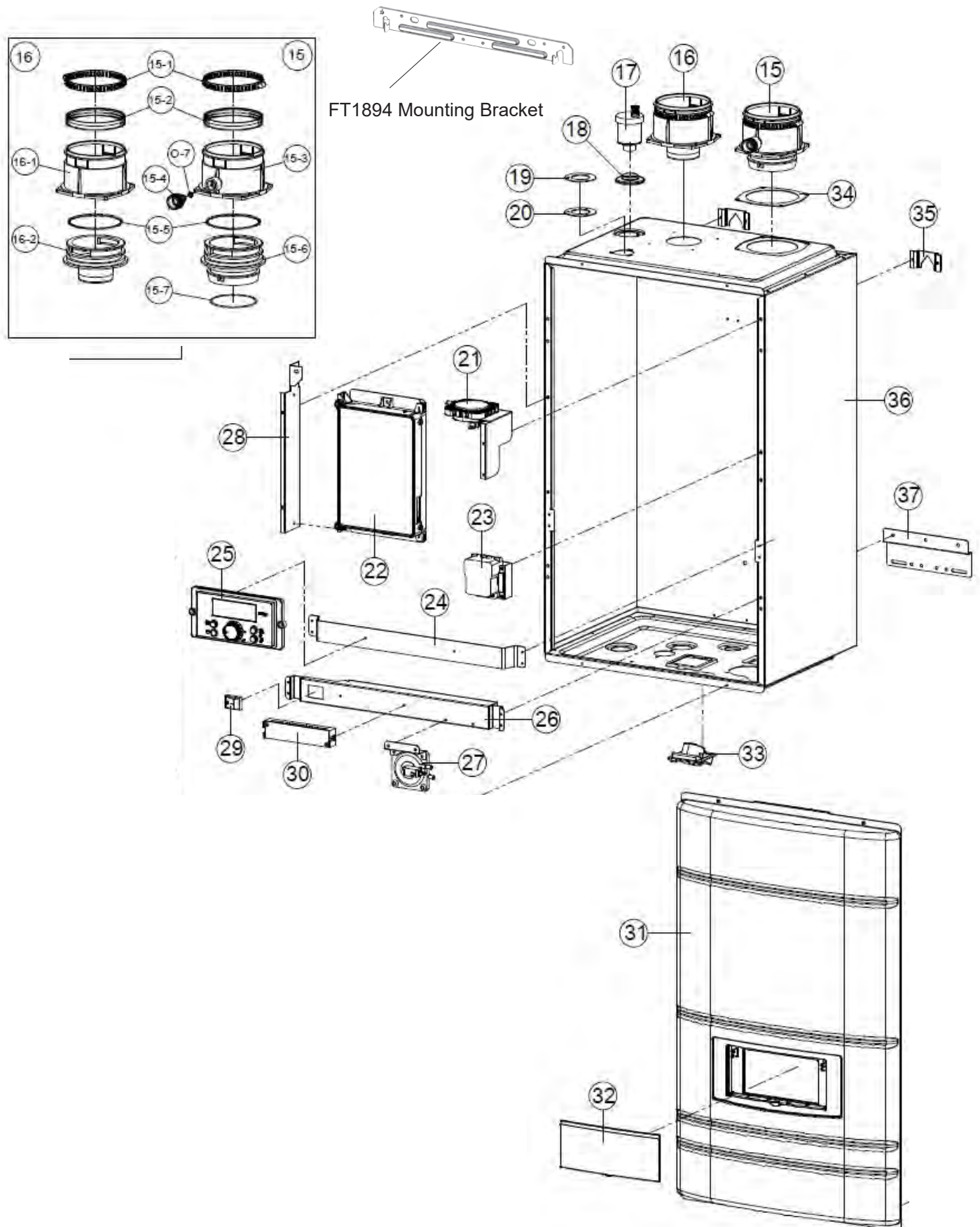
- Final check : Installation Conditions.
  - Is the Boiler properly mounted on the wall?
  - Is there space for a drain which is close to the Boiler?
  - Are there any combustibile materials near the Boiler and vent pipe?
  - Is the air supply sufficient for proper operation of the Boiler?
  - Are the proper service clearances maintained?
  - Is the distance between the Boiler and point of vent termination minimized?
  - Is the proper distance from windows, doors, and other intake vents maintained?
- Final check : Gas pipe installation
  - Is the gas supply line equipped with a manual shut off valve?
  - Is the gas supply line a minimum of 3/4" inner diameter?
  - Is the gas supply line length and diameter adequate to deliver the required BTU's?
  - Has the gas supply line pressure been measured?
  - Does the supply gas type match the type indicated on the boiler rating plate?
- Final check: Air/Vent pipe installation
  - Has the Boiler been vented with 3" or 2" PVC, CPVC, Polypropylene or BH Special Gas Vent (S636 PVC, CPVC) for Category IV appliances in accordance with this manual and/or your local code?
  - Is the vent termination at least 12" above the exterior grade?
  - Is the total vent length within the maximum vent length restriction?
  - Have you checked the air/vent piping for leaks?
  - Have you properly supported the vent termination?
  - Are all vent runs properly supported?
  - Is the vent sloped upward toward the vent termination at a rate of 1/4" per foot (2% grade)?
- Final check : Condensate drain installation
  - Have you installed a condensate drain line from the Boiler to a drain or laundry tub?
- Final check : Setting the DIP switches
  - Are all DIP switches correctly set on the main board?
- Final check : Connecting the power supply
  - Please check that the power is 120V AC.
  - Have you checked the polarity of the electrical connection?
- Final check : Pressure relief valve
  - Have you properly installed an approved pressure relief valve on the boiler?
  - If applicable, has the DHW pressure relief valve been properly installed. This will be dependent on local codes.
- Final check : Burner flames
  - The burner flame must be checked periodically for a constant proper blue color.
  - If the flame does not appear normal, the burner may need to be cleaned.
  - If the burner needs to be cleaned, it must be performed by a qualified service technician.



This page intentionally left blank.

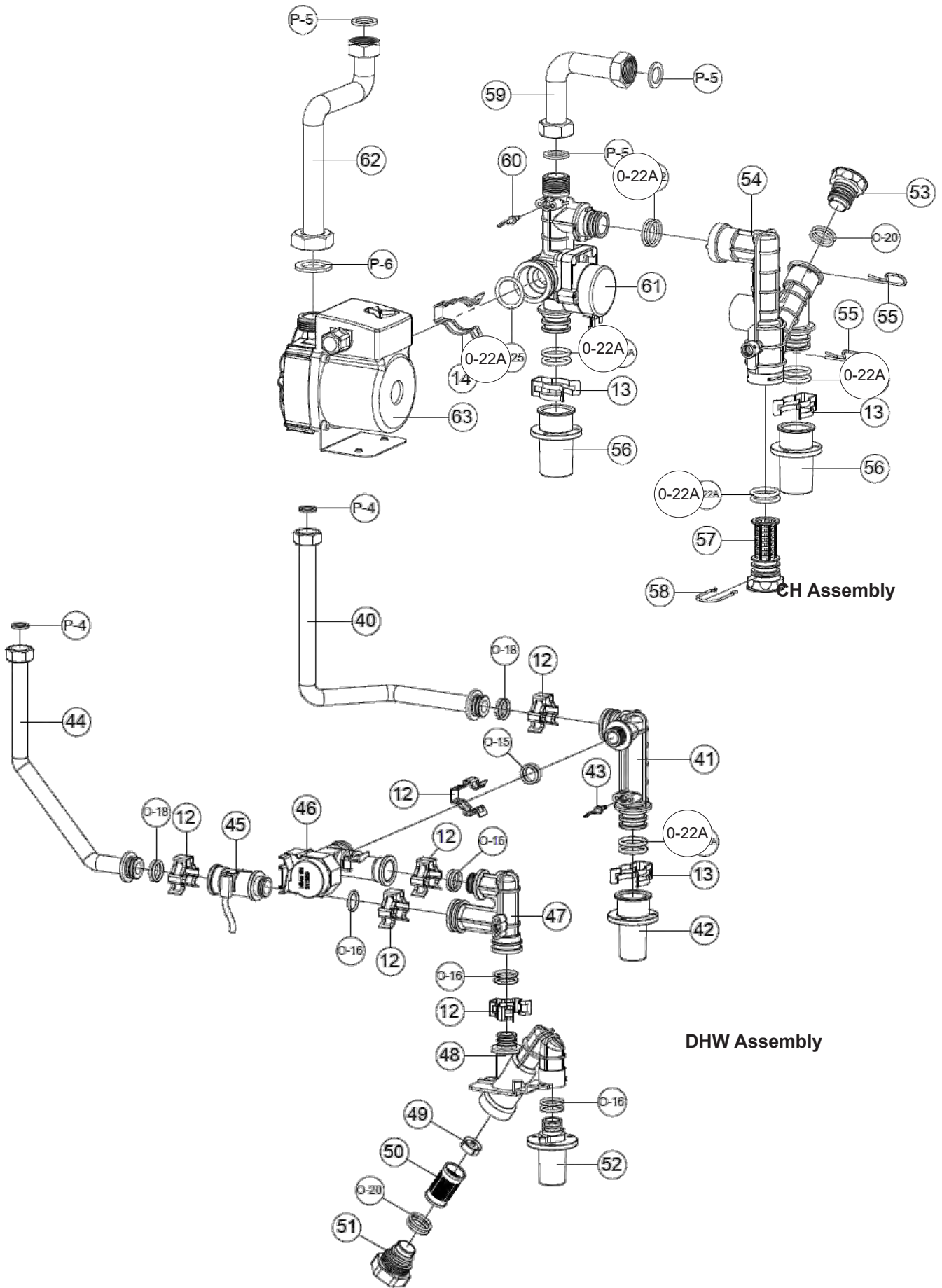
# SECTION 10 Parts List and Illustrations

## FTCW140



<b>No.</b>	<b>Description</b>	<b>Part Number</b>
O-7	O-Ring P7	FT1601
15	Exhaust vent duct Assembly	FT1002
15-1	Stainless band (Ø100)	FT1603
15-2	Packing	FT1604
15-3	Exhaust vent duct	FT1611
15-4	Exhaust testing cap	FT1606
15-5	O-Ring P85	FT1607
15-6	Exhaust vent adaptor (Inside)	FT1608
15-7	O-Ring P75	FT1609
16	Air inlet duct Assembly	FT1010
16-1	Air inlet duct	FT1605
16-2	Air inlet adaptor (Inside)	FT1612
17	Air vent	FT1321
18	Air vent rubber packing	FT1013
19	Gasket bracket	FT1797
20	Safety valve rubber pad	FT1921
21	Air pressure sensor (80)	FT1804
22	PCB Control (NGTX-900CP)	FT1899
23	Ignition transformer	ST1006
24	Control sub-bracket	FT1954
25	Display Control (P-920C)	FT1620
26	Bracket	FT1511
27	Condensate blockage, Air press switch	FT1022
28	Control bracket	FT1922
29	Power switch	FT1020
30	Terminal block (10P)	FT1021
31	Front cover	FT1923
32	Control display cover / window	FT1024
33	Pressure gauge	FT1025
34	Intake/Exhaust sealing pad	FT1771
35	Wall Mount bracket (top)	FT1924
36	Casing Assembly	N / A
37	Wall Mount bracket (bottom)	FT1936

IOM Ref Part Number Description





**CH Assembly**

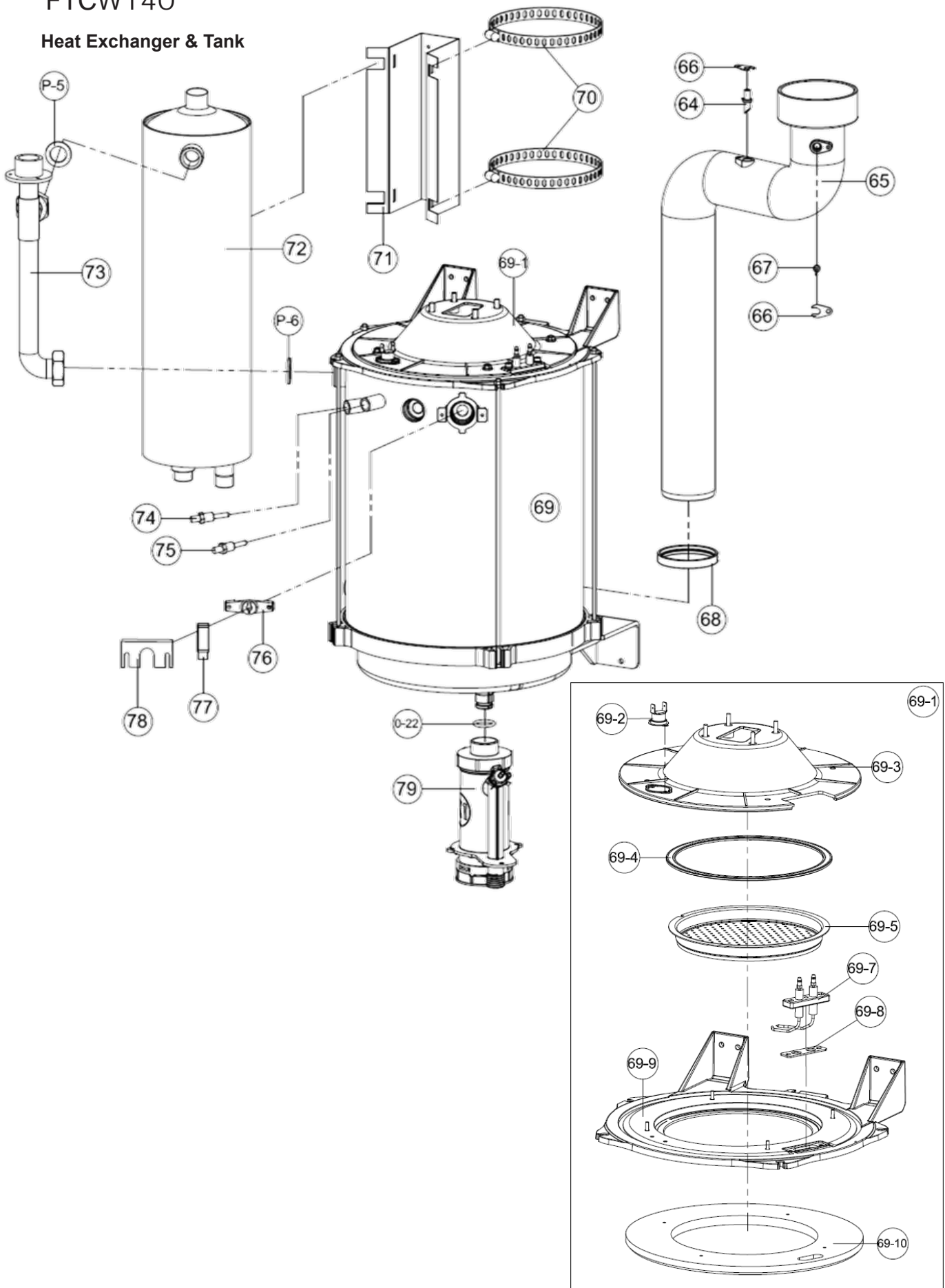
No.	Description	Part Number
B2	CH Hydro block Assembly	FT1100
O-20	O-Ring P20	FT1513
O-22	O-Ring P22	FT1644
O-22A	O-Ring P22A	FT1515
O-25	O-Ring P25	FT1516
P-5	3/4" Packing	FT1646
P-6	1" Packing	FT1691
13	Piping clip	FT1107
14	Pump clip	FT1108
53	Block cap	FT1121
54	Return block	FT1523
55	R Clip	FT1524
56	CH Return, Supply connector	FT1215
57	CH Filter	FT1216
58	U Clip	FT1217
59	CH Return pipe	FT1218
60	CH Return sensor	FT1219
61	3-way valve	FT1220
62	CH Supply pipe	FT1527
63	Pump	FT1222

**DHW Assembly**

No.	Description	Part Number
B3	DHW Hydro block Assembly	FT1200
O-15	O-Ring P15	FT1685
O-16	O-Ring P16	FT1643
O-18	O-Ring P18	FT1687
O-20	O-Ring P20	FT1513
O-22A	O-Ring P22A	FT1515
P-4	1/2" Packing	FT1645
12	Flow sensor clip	FT1208
13	Piping clip	FT1107
40	DHW Outlet pipe	FT1109
41	DHW Outer block	FT1518
42	DHW Nipple	FT1111
43	DHW Temperature sensor	FT1112
44	DHW Inlet pipe	FT1114
45	Flow sensor	FT1115
46	Mixing valve	FT1116
47	DHW Inlet block	FT1522
48	DHW Filter body	FT1549
49	Flow restrictor (12L)	FT1119
50	DHW Filter mesh	FT1120
51	Block cap	FT1121
52	DHW Connector	FT1122

# FTCW140

## Heat Exchanger & Tank



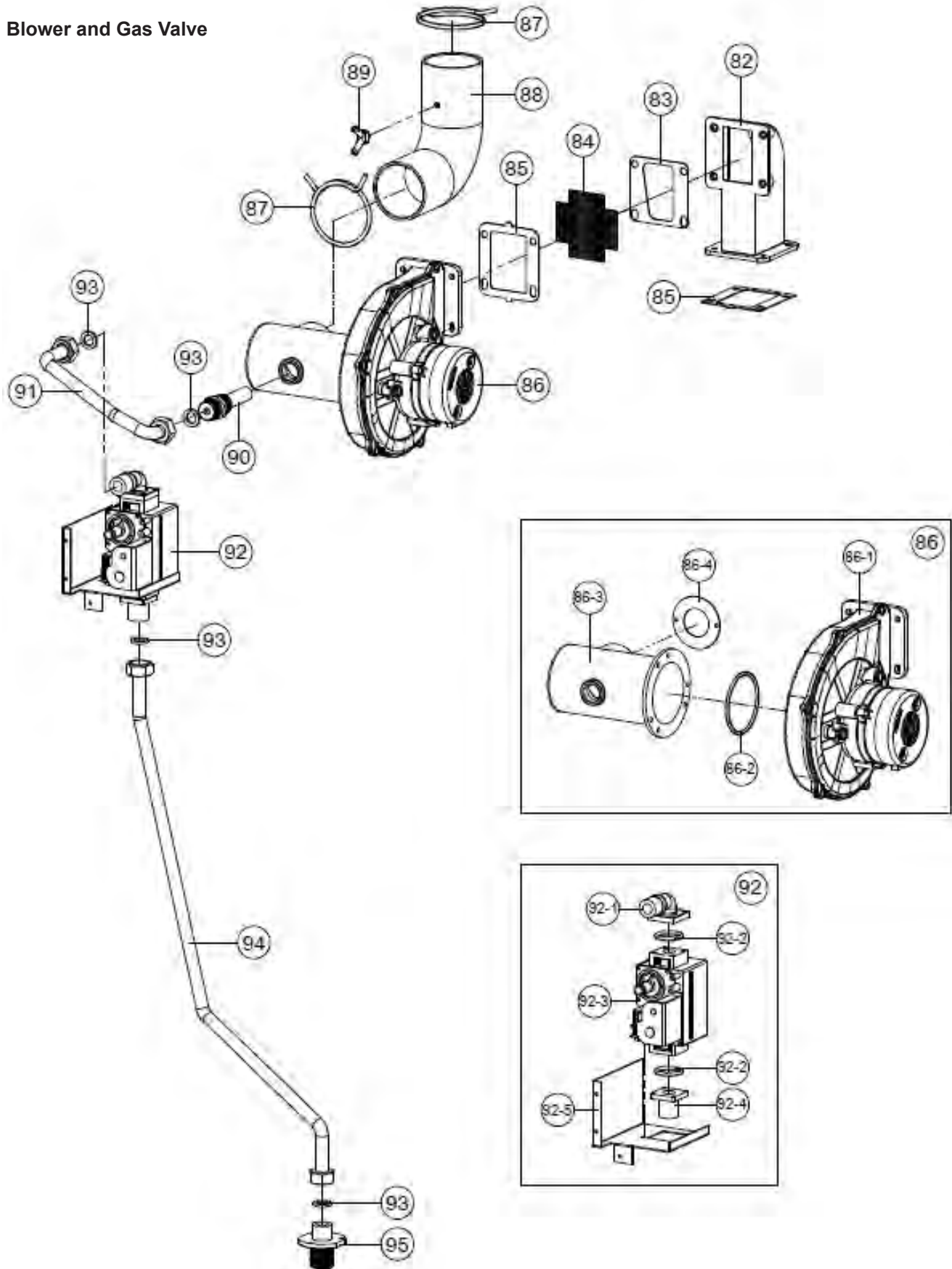
FTCW140

Heat Exchanger & Tank

No.	Description	Part Number
O-22	O-Ring P22	FT1644
P-5	3/4" Packing	FT1646
P-6	1" Packing	FT1691
64	EX-Adaptor	FT1784
65	Exhaust pipe	FT1067
66	Exhaust sensor bracket	FT1529
67	Exhaust overheat sensor	FT1307
68	Exhaust pipe packing (lower)	FT1666
69	Heat Exchanger Assembly	FT1313
69-1	Burner Assembly	FT1925
69-2	Overheat sensor	FT1310
69-3	Burner upper case	FT1926
69-4	Burner packing	FT1927
69-5	Burner	FT1314
69-7	Ignition rod	FT1315
69-8	Ignition rod gasket	FT1316
69-9	Burner downside case	FT1928
69-10	Refractory	FT1665
70	Stainless band (Ø150)	FT1528
71	DHW Tank bracket	FT1530
72	DHW Tank	FT1323
73	CH Supply upper pipe	FT1322
74	Temperature sensor	FT1324
75	Low level sensor	FT1325
76	Flame detector sensor bracket	FT1669
77	Flame detector sensor	FT1327
78	Flame detector sensor cover	FT1069
79	Condensate trap Assembly	FT1783

# FTCW140

## Blower and Gas Valve



**FTCW140**

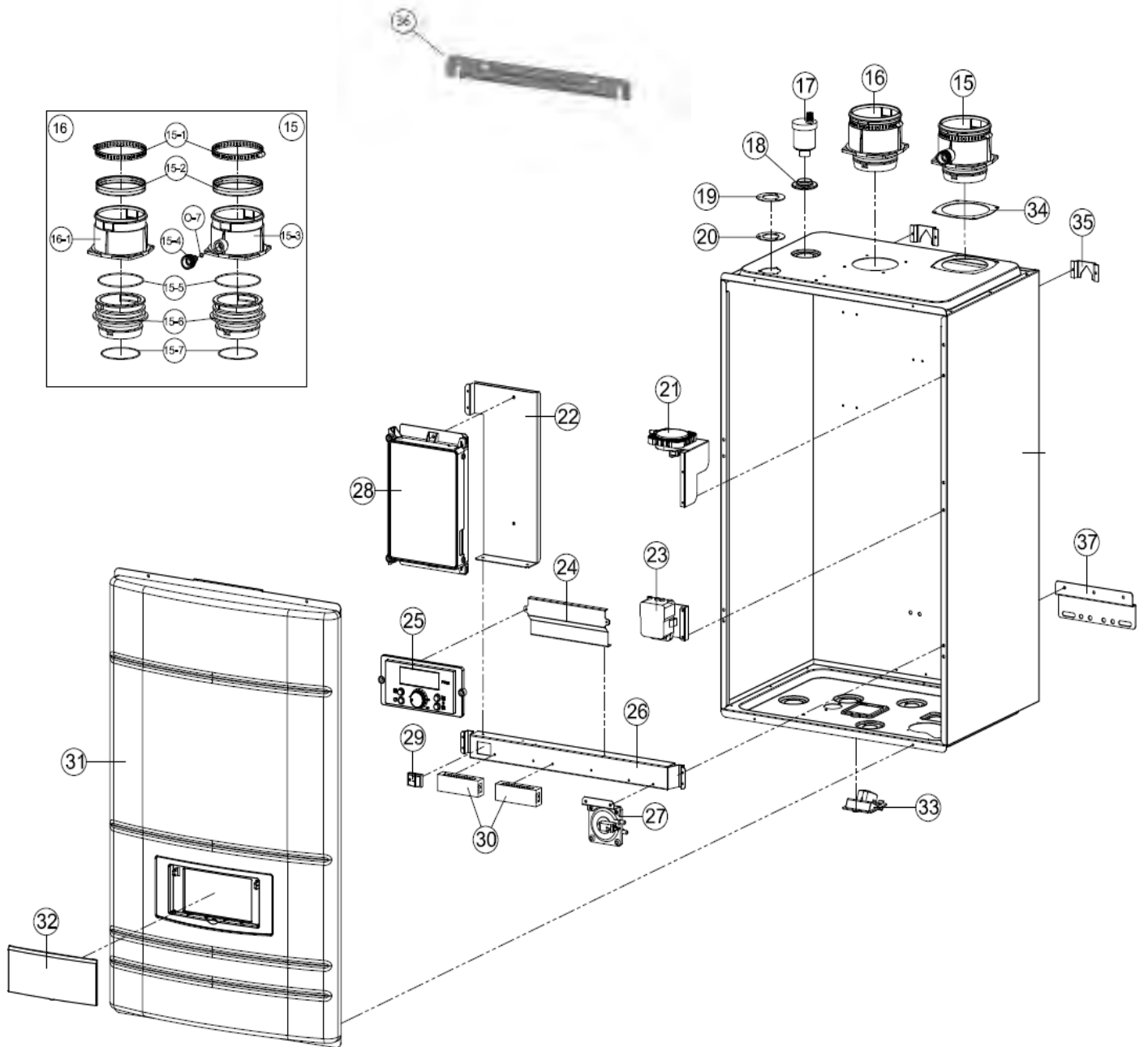
**Blower and Gas Valve**

No.	Description	Part Number
82	Fan guide	FT1532
83	Fan rubber packing (1.0t)	FT1721
84	Mash	FT1720
85	Fan rubber packing (1.6t)	FT1082
86	Fan Assembly	FT1407
86-1	Fan	FT1406
86-2	Fan sealing O-Ring	ST1038
86-3	Gas mixer housing	FT1409
86-4	Intake orifice (140K)	FT1535
87	Stainless band (Ø60)	FT1078
88	Air intake hose (120,140K)	FT1533
89	Nylon Barb Y Fitting	FT1918
90	Nozzle (Natural/140K)	FT1412N
	Nozzle (Propane/140K)	FT1412P
91	Gas pipe (upper)	FT1536
92	Gas valve Assembly	FT1413
92-1	Gas valve outlet adaptor	FT1919
92-2	Gas valve O-Ring	FT1727
92-3	Gas valve	FT1416
92-4	Gas valve inlet adaptor	FT1538
92-5	Gas valve bracket	FT1539
93	1/2" Spiral packing	FT1710
94	Gas pipe(down)	FT1419
95	Gas inlet adaptor	FT1893

**Optional Items**

No.	Description	Part Number
100	Pressure Relief Valve	FT1500
101	Outdoor Temp. Sensor	FT1501
102	Bird Screen 3"	FT1730
104	Spare Parts Kit	FT1930
105	Condensate Hose	ST1070
106	Restrictor (12L)	FT1506
107	Wall Hung Bracket	FT1894
108	Bird Screen 2"	FT1508
109	Nozzle LNG 7.1 (3,000~10,000ft)	FT1931
110	Nozzle LNG 5.0 (3,000~6,500ft)	FT1932
111	Nozzle LNG 5.1 (6,500~10,000ft)	FT1933
112	Nozzle LNG 6.2 (3,000~10,000ft)	FT1934
113	Nozzle LNG 4.8 (3,000~10,000ft)	FT1935
114	Wire Harness	FT1903

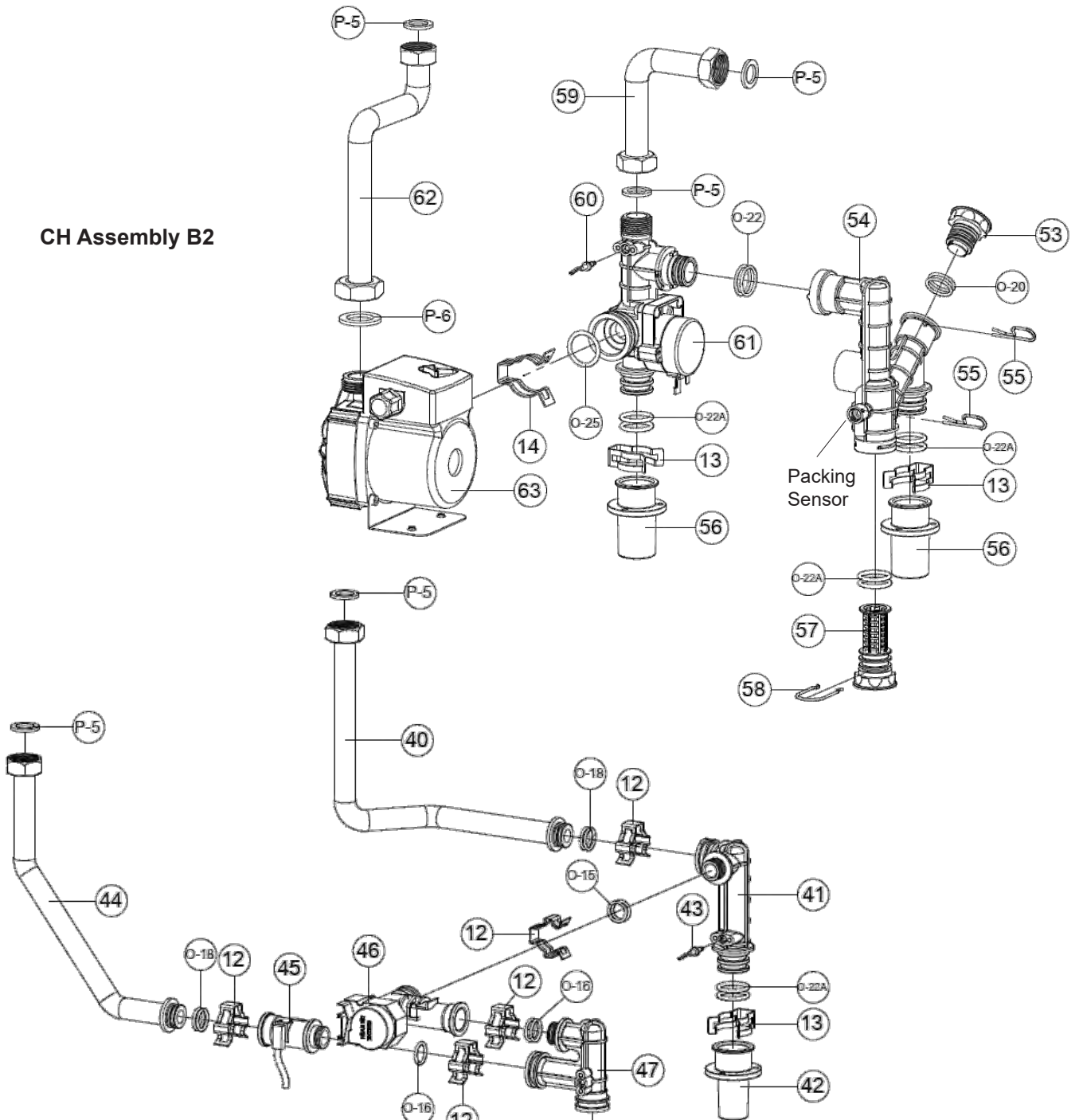
# FTCW199



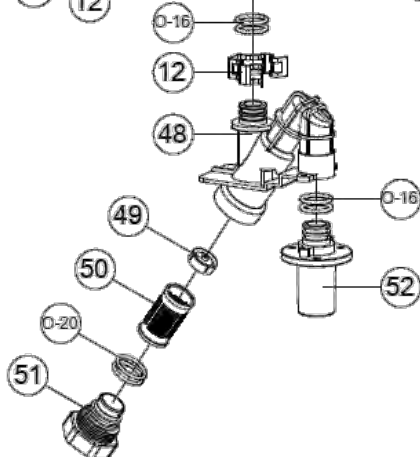
FTCW199

No.	Description	Part Number
O-7	O-Ring P7	FT1601
15	Exhaust vent duct Assembly	FT1002
15_1	Stainless band (Ø100)	FT1603
15_2	Packing	FT1604
15_3	Exhaust vent duct	FT1611
15_4	Exhaust testing cap	FT1606
15_5	O-Ring P85	FT1607
15_6	Exhaust vent adaptor (Inside)	FT1608
15_7	O-Ring P75	FT1609
16	Air inlet duct Assembly	FT1909
16_1	Air inlet duct	FT1605
17	Air vent	FT1321
18	Air vent rubber packing	FT1013
19	Gasket bracket	FT1797
20	Safety valve rubber pad	FT1921
21	Air pressure sensor (80)	FT1804
22	Control bracket	FT1751
23	Ignition transformer	ST1006
24	Control sub-bracket	FT1752
25	Display Control (P-920C)	FT1620
26	Bracket	FT1795
27	Condensate blockage, Air pressure switch	FT1022
28	PCB Control (NGTX-900CP)	FT1899
29	Power switch	FT1020
30	Terminal block (6P)	FT1827
31	Front cover	FT1920
32	Control display cover / window	FT1024
33	Pressure gauge	FT1025
34	Intake/exhaust sealing pad	FT1771
35	Wall hung bracket (top)	FT1924
36	Wall Mount Bracket	FT1894
37	Wall hung bracket (bottom)	FT1936

### CH Assembly B2



### DHW Assembly B3





# FTCW199

## CH Assembly B2

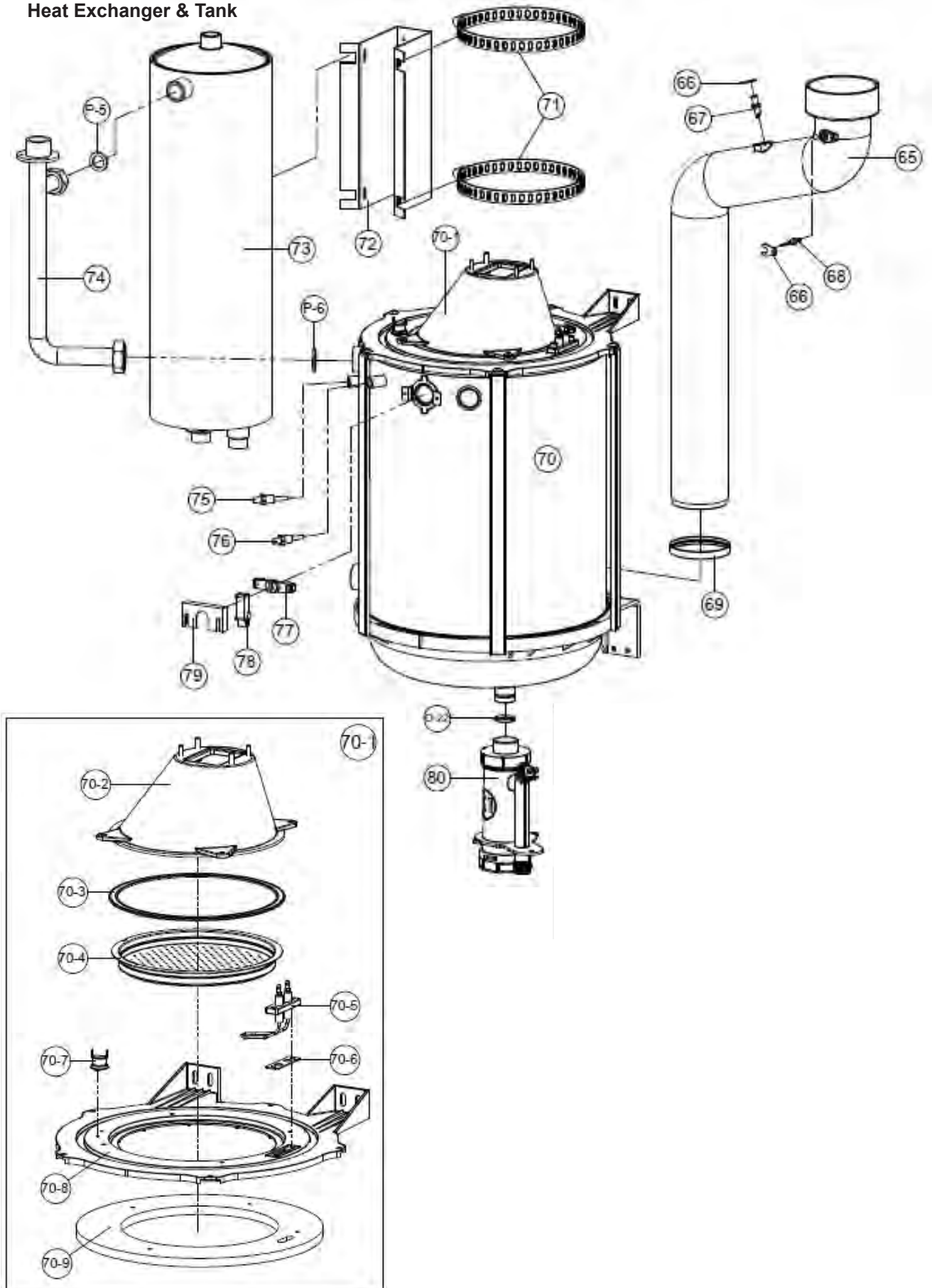
No.	Description	Part Number
B2	CH Hydro block Assembly	FT1937
O-20	O-Ring P20	FT1513
O-22	O-Ring P22	FT1644
O-22A	O-Ring P22A	FT1515
O-25	O-Ring P25	FT1516
P-5	3/4" Packing	FT1646
P-6	1" Packing	FT1691
13	Piping clip	FT1107
14	Pump clip	FT1108
53	Block cap	FT1121
54	Return block	FT1523
55	R Clip	FT1524
56	CH Return, Supply connector	FT1215
57	CH Filter	FT1216
58	U Clip	FT1217
59	CH Return pipe	FT1807
60	CH Return sensor	FT1219
61	3way valve	FT1220
62	CH Supply pipe	FT1808
63	Pump	FT1798

## DHW Assembly B3

No.	Description	Part Number
B3	DHW Hydro block Assembly	FT1938
O-15	O-Ring P15	FT1685
O-16	O-Ring P16	FT1643
O-18	O-Ring P18	FT1687
O-20	O-Ring P20	FT1513
O-22A	O-Ring P22A	FT1515
P-5	3/4" Packing	FT1646
12	Flow sensor clip	FT1208
13	Piping clip	FT1107
40	DHW Outlet Pipe	FT1805
41	DHW Outer block	FT1518
42	DHW Nipple	FT1111
43	DHW Temperature sensor	FT1112
44	DHW Inlet pipe	FT1806
45	Flow sensor	FT1115
46	Mixing valve	FT1116
47	DHW Inlet block	FT1522
48	DHW Filter body	FT1549
49	Flow restrictor	FT1822
50	DHW Filter mesh	FT1120
51	Block cap	FT1121
52	DHW Connector	FT1122

# FTCW199

## Heat Exchanger & Tank



**FTCW199**

**Heat Exchanger & Tank**

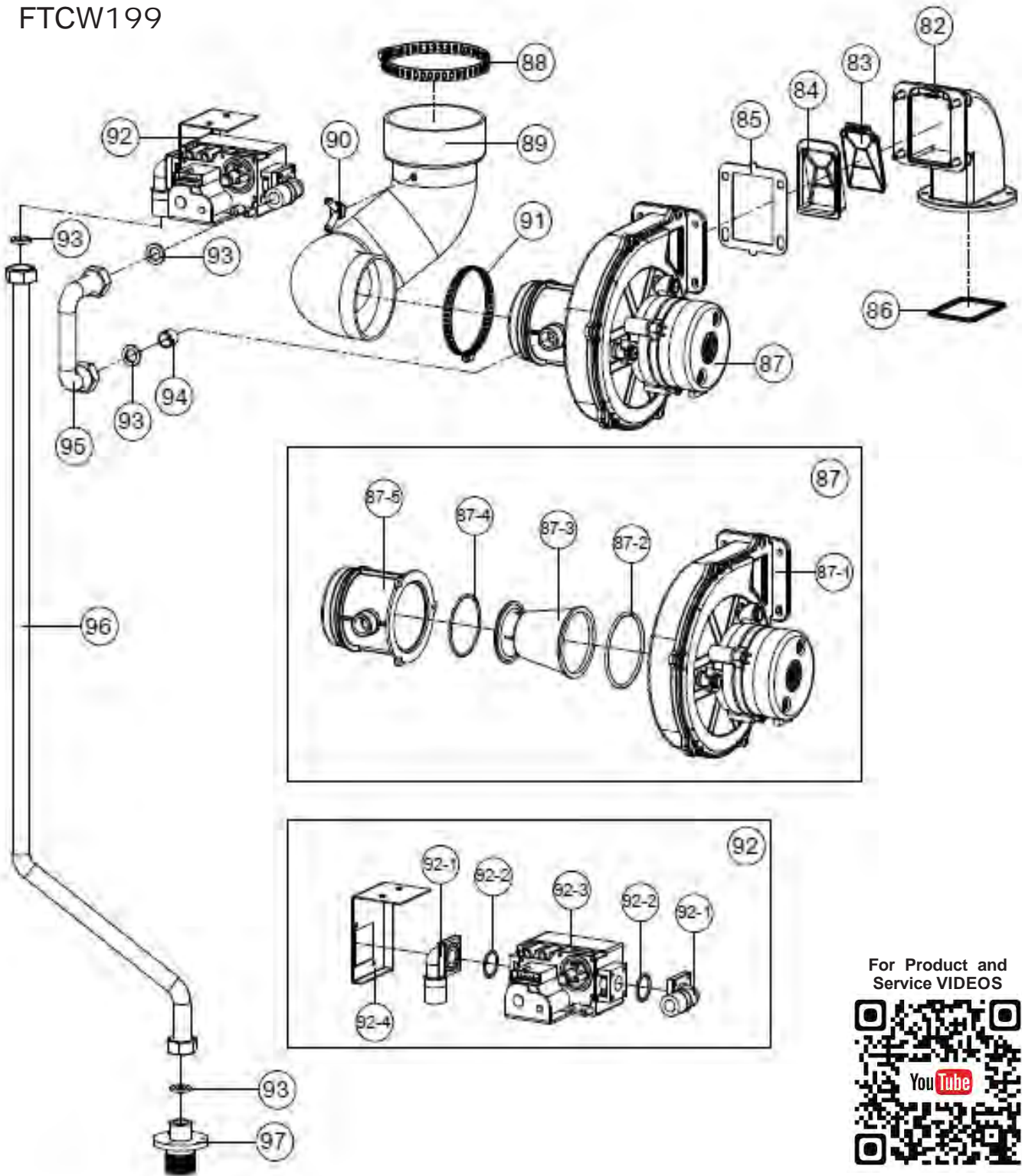
No.	Description	Part Number
O-22	O-Ring P22	FT1644
P-5	3/4" Packing	FT1646
P-6	1" Packing	FT1691
65	Exhaust pipe	FT1823
66	Exhaust sensor bracket	FT1529
67	EX-Adaptor	FT1784
68	Exhaust overheat sensor	FT1307
69	Exhaust pipe packing (lower)	FT1836
70	Heat Exchanger Assembly	FT1992
70-1	Burner Assembly	FT1796
70-2	Burner upper case	FT1760
70-3	Burner packing	FT1824
70-4	Burner	FT1762
70-5	Ignition rod	FT1763
70-6	Ignition rod gasket	FT1316
70-7	Overheat sensor	FT1310
70-8	Burner downside case	FT1764
70-9	Refractory	FT1826
71	Stainless band (Ø165)	FT1813
72	DHW Tank bracket	FT1793
73	DHW Tank	FT1794
74	CH Supply upper pipe	FT1809
75	Temperature sensor	FT1324
76	Low level sensor	FT1325
77	Flame detector sensor bracket	FT1669
78	Flame detector sensor	FT1327
79	Flame detector sensor cover	FT1069
80	Condensate trap Assembly	FT1783

**Blower and Gas Valve (next page)**

No.	Description	Part Number
82	Fan guide	FT1769
83	Damper packing	FT1770
84	Damper body	FT1915
85	Fan rubber packing (1.6t)	FT1082
86	Fan guide packing	FT1772
87	Fan Assembly	FT1916
87-1	Fan	FT1406
87-2	Fan sealing O-Ring	ST1038
87-3	AGM Venturi	FT1917
87-4	AGM O-Ring	FT1774
87-5	AGM Body	FT1775
88	Stainless band (Ø100)	FT1603
89	Air intake hose	FT1812
90	Nylon Barb Y Fitting	FT1918
91	Stainless band(Ø89)	FT1777
92	Gas valve Assembly	FT1778
92-1	Gas valve outlet adaptor	FT1919
92-2	Gas valve O-ring	FT1727
92-3	Gas valve	FT1416
92-4	Gas valve bracket	FT1779
93	1/2" Spiral packing	FT1710
94	Nozzle (natural)	FT1780
	Nozzle (propane)	FT1802
95	Gas pipe (upper)	FT1810
96	Gas pipe (down)	FT1811
97	Gas inlet adaptor	FT1893

**The FT Series Wall Mounted, Combination Boiler**

FTCW199



Dimensions and specifications subject to change without notice in accordance with our policy of continuous product improvement.

H2372800G



Customer Service and Product Support: 800.900.9276 • Fax 800.559.1583  
 20 Industrial Way, Rochester, NH, USA 03867