

# SPXC, SPXC-HP, SPXC-HW SERIES PACKAGED AIR CONDITIONING/HEAT PUMP UNITS

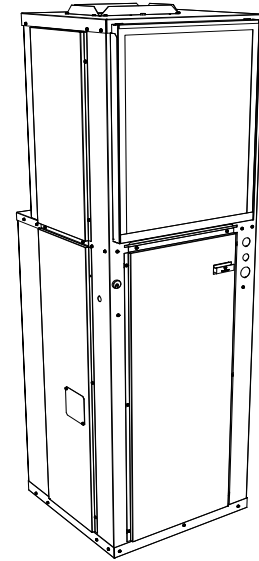

## Installation, Operation, and Maintenance Instructions

---

### WARNING TO INSTALLER, SERVICE PERSONNEL, AND OWNER

Altering the product, improper installation, or replacing parts with unauthorized parts voids all warranty or implied warranty and may result in adverse operational performance or possible hazardous conditions to service personnel and occupants. Company employees or contractors are not authorized to waive this warning. Current Maintenance Program is available [HERE](#).

---



- NOTES:
- *Read the entire installation instruction manual before starting the installation.*
  - *These instructions are intended as a general guide and do not supersede national, state, or local codes in any way.*
  - *These instructions must be left with the property owner.*

### *SAFETY CONSIDERATIONS*

---

Improper installation, adjustment, alteration, service, maintenance, or use can cause explosion, fire, electrical shock, or other conditions which may cause personal injury or property damage. Consult a qualified licensed installer, service agency, or your distributor for information or assistance. The qualified licensed installer or service agency must use factory-authorized kits or accessories when modifying this product. Refer to the individual instructions packaged with kits or accessories when installing.

Follow all safety codes. Wear safety glasses and work gloves. Use quenching cloth for brazing operations. Have fire extinguisher available. Read these instructions thoroughly and follow all warnings or cautions attached to the unit. Consult local building codes and National Electrical Code (NEC) for special requirements.

Recognize safety information. This is the general safety-alert symbol . When you see this symbol on the unit and in instruction manuals, be alert to the potential for personal injury or damage to equipment. The lightning bolt symbol  signifies an electrical shock hazard.

 **WARNING:** *This WARNING signifies general hazards which could result in personal injury or death.*

 **WARNING:** *This WARNING signifies electrical shock hazards which could result in personal injury or death.*

 **CAUTION:** *CAUTION is used to identify unsafe practices which would result in product and property damage.*

**NOTE:** *NOTE is used to highlight suggestions which may result in enhanced installation, reliability, or operation.*

## GENERAL

---

The manufacturer does not warrant equipment subjected to abuse. Metal chips, dust, drywall tape, paint overspray, etc. can void warranties and liability for equipment failure, personal injury, and property damage.

The manufacturer assumes no responsibility for equipment installed in violation of any code requirement.

-  **WARNINGS**
- Always wear eye protection when working on equipment.
  - Before servicing unit, always turn off all power to unit. There may be more than one disconnect switch. Electrical shock can cause personal injury or death.
  - When unit is operating, some components are operating at high speeds. Personal injury can result from touching these components with any object.
  - All electrical and service access panels must be secured in their proper place before operating equipment.
  - Clear surrounding area of all tools, equipment and debris before operating unit.

 **CAUTION:** Unit must not be operated during building construction due to excessive airborne dust and debris. Also, the unit must never run under any circumstances without an air filter in place.

These instructions give information relative to the SPXC unit only. Refer to Wall Sleeve and Grille installation instructions for those components. For other related equipment refer to proper instructions.

The SPXC is shipped in one package, completely assembled. Material in this shipment has been inspected at the factory and released to the transportation agency in good condition. When received, a visual inspection of all cartons should be made immediately. Any evidence of rough handling or apparent damage should be noted on the delivery receipt and the material inspected in the presence of the carrier's representative. If damage is found, a claim should be filed against the carrier immediately.

All models are designed for indoor installation only. The installation of this unit, field wiring, duct system, and other related equipment must conform to the requirements the National Electric Code, ANSI/NFPA No. 70 (latest edition)

in the United States, as well as any state laws and local codes. Local authorities having jurisdiction should be consulted before installation is made. Such applicable regulations take precedence over the general instructions contained in this manual.

**NOTE:** *HW Units- State of MA.-248 CMR code of the state of MA. requires a pump timer (60 seconds on every 6 hours).*

**PACKING LIST**      Items packed inside the unit:  
(1) Filter Bracket

**FIGURE 1.** Typical Suite Installation

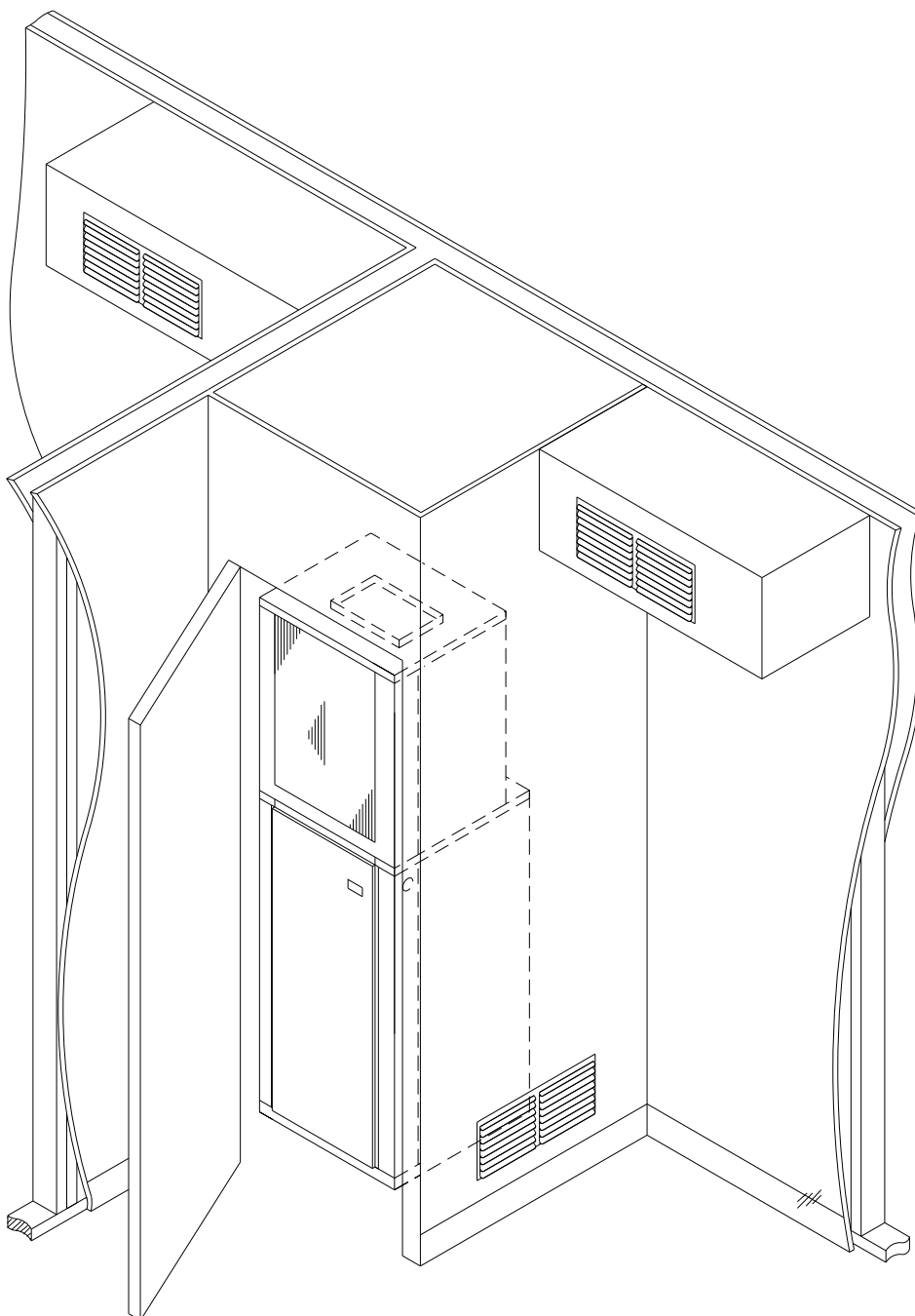

---

## LOCATION

---

The SPXC is designed for through-the-wall installation. The interior portion of the unit is surrounded by a closet with a rear access (Figure.1). The vertical discharge allows for ducting to the top of the room for best air circulation and elimination of cold drafts on occupants. The exterior (grille side) of the unit must have no obstructions (trees, landscape materials, etc.) within 18 inches. Do not locate two units adjacent to each other on an inside corner or where they may exhaust into each other.

Provisions should be made to allow access to the indoor side of the unit for installation and inspection. The closet or access panel opening must be centered with the exterior wall opening and be at least 24 inches wide by 84 inches tall for the 9SPXC, 12SPXC, 18SPXC. The exterior wall opening must be at least 30 inches wide by 84 inches tall for the 24SPXC, and 30SPXC.

3 inches of unobstructed clearance must be maintained around the SPXC chassis on all sides for adequate airflow to achieve optimum performance. These guidelines give minimum spacing requirements only. It is acceptable to go beyond these limits at any time. At least 27 inches of unobstructed space should be provided in front of the access door to permit removal of the unit, should repair and inspection be required.

For installations requiring access panels refer to page 6 for panel dimensions.

### NOISE

These SPXC units are designed for quiet operation, however, all air conditioning equipment will transfer some amount of noise to the conditioned space. This should be taken into consideration when planning the location of the equipment.

NOTE: *Architectural Grille must be installed prior to the installation of the SPXC unit into sleeve.*

---

## WALL SLEEVE INSTALLATION

---

Refer to installation instructions packed with wall sleeve to assemble and mount it in the wall. Before unit installation, make sure sleeve components are not damaged, drain line is not unobstructed and leak free.

Check all seals to ensure that they are in position and un-damaged. Ensure that the bottom of the wall sleeve is pitched 1/2 bubble toward the outside of the building so that rain water will drain to the outside (Figure. 6). Securely fasten the Architectural grille to the front of the sleeve using the supplied hardware.

NOTE: *After sleeve installation, ensure that the sleeve seal is in contact with the sleeve sides. Any air gaps must be sealed or outdoor air and/or water leakage will occur.*

NOTE: *Make sure a high grade non-hardening sealant approved for exterior use has been applied between edge of the sleeve and the structure, on the inside and outside walls, to prevent air and water from migrating inside (Figure. 6).*

FIGURE 2. Small Sleeve Closet Installation and Dimensions

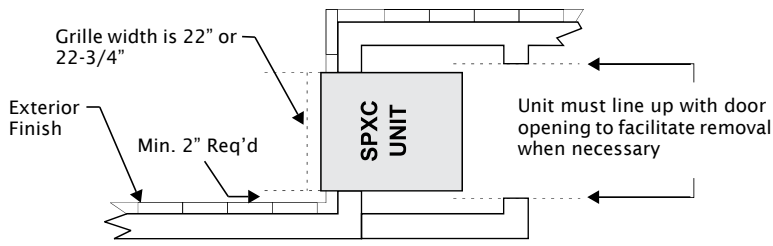

Notes:

1. Sleeve rough-in opening is 44"(H) x 21-5/8"(W).
2. Bottom of opening should be approx. 6" above floor level.
3. Minimum 3" of clearance is required on all sides of the SPXC unit.

Note:  
Provide minimum clearances as shown for interior closet dimensions

SIDE INSTALLATION

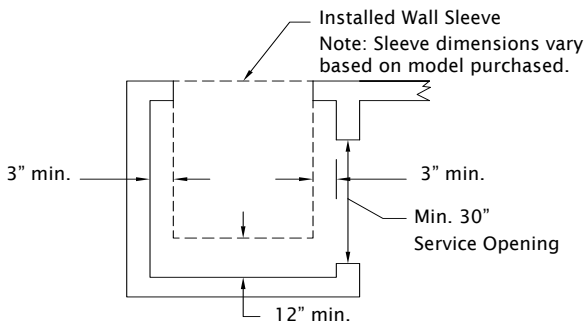

REAR INSTALLATION

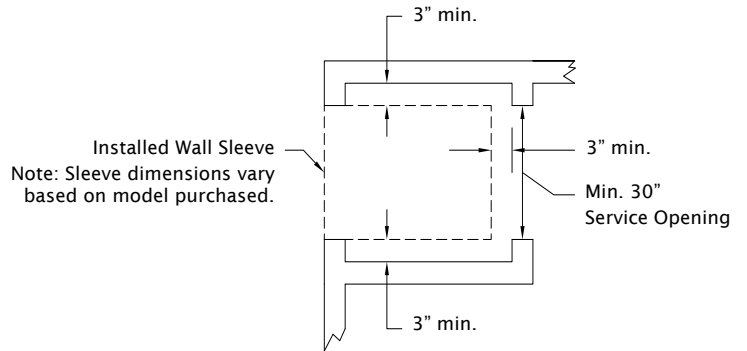

Notes:

1. Sleeve should be installed in exterior wall prior to constructing closet.
2. Sleeve rough-in opening is 44"(H) x 21-5/8"(W).
3. Bottom of opening should be approx. 6" above floor level.
4. Minimum 3" of clearance is required on all sides of the SPXC unit and 12" clearance on the rear of the unit.

Large Sleeve Closet Installation and Dimensions

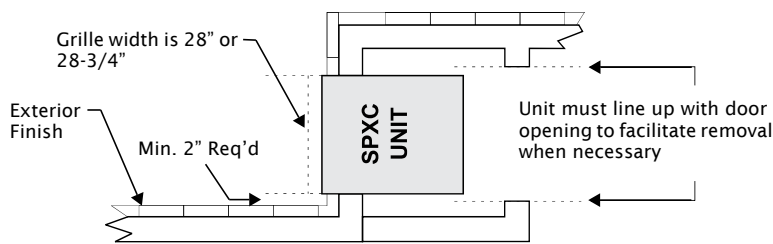

Notes:

1. Sleeve rough-in opening is 44"(H) x 27-5/8"(W).
2. Bottom of opening should be approx. 6" above floor level.
3. Minimum 3" of clearance is required on all sides of the SPXC unit.

Note:  
Provide minimum clearances as shown for interior closet dimensions

SIDE INSTALLATION

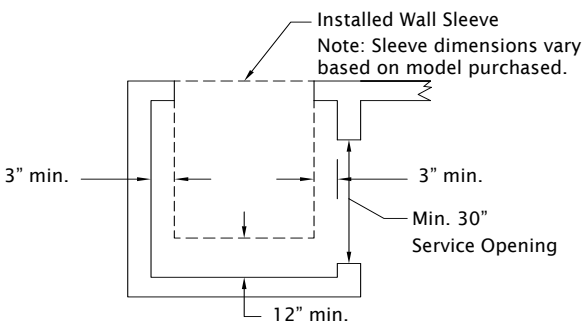

REAR INSTALLATION

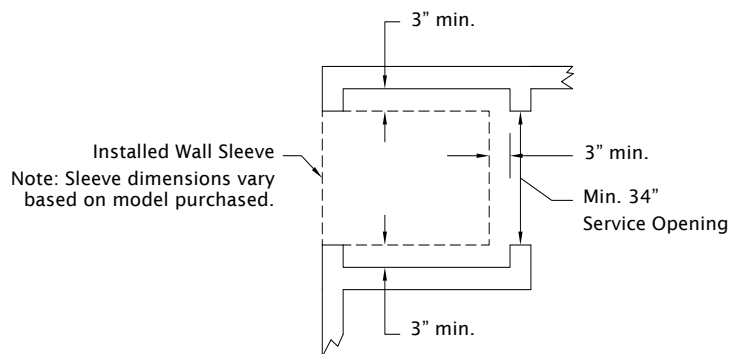

Notes:

1. Sleeve should be installed in exterior wall prior to constructing closet.
2. Sleeve rough-in opening is 44"(H) x 27-5/8"(W).
3. Bottom of opening should be approx. 6" above floor level.
4. Minimum 3" of clearance is required on all sides of the SPXC unit and 12" clearance on the rear of the unit.

FIGURE 3. ACCESS PANEL DIMENSIONS

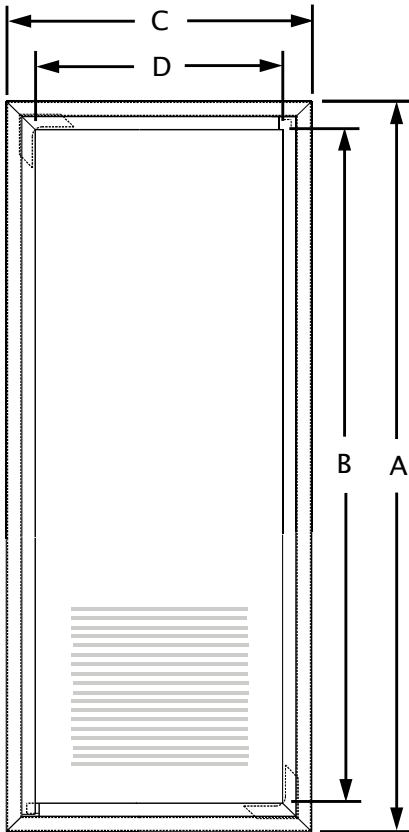

Access Panel Dimensions

DESCRIPTION	PART NO.	A	B	C	D
LOUVERED	931-11	87"	84"	31"	28"
NON-LOUVERED	931-12	87"	84"	31"	28"
LOUVERED	931-13	82"	79"	31"	28"
NON-LOUVERED	931-14	82"	79"	31"	28"
* LOUVERED	931-15	87"	84"	37"	34"
* NON-LOUVERED	931-16	87"	84"	37"	34"
* LOUVERED	931-17	82"	79"	37"	34"
* NON-LOUVERED	931-18	82"	79"	37"	34"

NOTES:

- Includes 18 x 24 x 1 or 20 x 24 x 1 Filter.
- Requires external return air grille and unit mount filter.
- Both panels are insulated for sound reduction and have tamper proof screws.
- Panels are shipped ten per carton.

\*For Rear Installation Use with size 24 and 30

## INSTALLATION PRECAUTIONS



**WARNING:** Some units are very heavy. Use two or more people when moving and installing these units. Failure to do so could result in personal injury or death. Contact with metal edges and corners while applying excessive force can result in personal injury. Use gloves when handling equipment. Use caution during installation or while servicing equipment.

Installation of this unit should be performed only by a licensed contractor to ensure proper installation and the safety of the installer. Observe the following precautions for typical installations:

- Always use proper tools and equipment.
- No wiring or other work should be attempted without first ensuring unit is completely disconnected from the power source and locked out. Always verify that a good permanent, uninterrupted ground connection exists prior to energizing any power sources.
- Always review the nameplate and wiring diagram on each unit for proper voltage and control configurations. This information is determined from the components and wiring of the unit and may vary from unit to unit.
- When soldering or brazing to the unit, it is recommended to have a fire extinguisher readily available. When soldering close to water valves or other components, heat shields or wet rags are required to prevent damage.
- When the unit is in operation, components are rotating at high speeds.
- Units must be installed level or angled toward the drain nipple to ensure proper drainage and operation.
- Be sure that the drain pan is free from foreign material prior to start up.
- Check filter media installation to ensure that it is installed correctly. Use the directional arrows or other information on the filter to determine the proper flow direction.
- Ensure air distribution system does not exceed the external static rating of the unit.

FIGURE 4. General Assembly

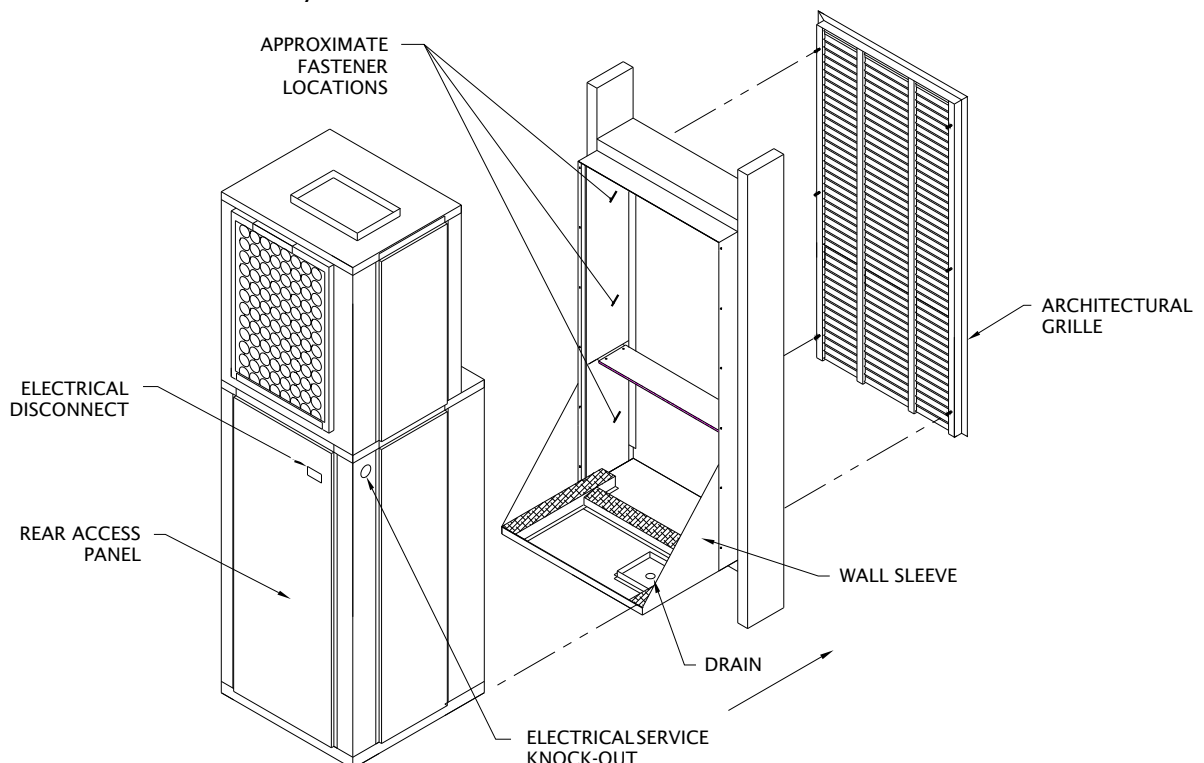

---

## SPXC INSTALLATION

---

Insulation is installed in indoor equipment to provide a barrier between outside air conditions surrounding the unit and the varying conditions inside the unit. If the insulating barrier is damaged, the surrounding ambient air will affect the inside surface temperature of the cabinet. The temperature / humidity difference between the inside and outside can cause condensation to form on the inside and outside of the cabinet which leads to sheet metal corrosion and subsequently, component failure.

Damaged insulation must be repaired or replaced before the unit is placed back into operation. Insulation loses its insulation value when wet, damaged, separated or torn.

The installer must adhere strictly to all local and national code requirements pertaining to the installation of this equipment. All units are designed for indoor use only, and are agency listed for installation with zero clearance to combustible materials. This includes the cabinet, discharge plenum and connecting ducts.

1. Remove the two clips holding the unit to the shipping pallet and remove unit from the shipping pallet.
2. Ensure that properly sized duct work is in place to mate to the supply connection on the SPXC.
3. Before setting unit into closet, remove upper side access panels and inspect the evaporator blower to ensure that the wheel turns freely without rubbing on the housing.

NOTE: *Remove the styrofoam shipping block supporting the blower assembly.*

Replace upper access doors prior to completing installation.

4. Remove disconnect and the rear access door to get to the loose items described in the packing list. Check all electrical connections and check the condenser fan to see that it turns freely.

NOTE: *Check nameplate voltage, amperage and fuse size for proper power supply.*

5. The SPXC is equipped with bend out flanges (Figure. 5), next to the evaporator coil, for the purpose of attaching a return air duct. If ducted return air is required these flanges must be bent 90 degrees away from the face of the evaporator coil along the perforation.

NOTE: *If the unit will not be connected to a fixed return duct these flanges must be broken off the unit.*

6. If an air filter is to be applied to the unit install the filter bracket by inserting the tab portion of the rack between the insulation and middle plate under the drain pan (Figure. 5). Place the filter into the filter rack. Insert the two tabs on the filter clip into the slots above the evaporator and hook the front flange under the filter flange to hold the filter in place.
7. A fresh air makeup vent is located on the lower left side door (Figure. 5). Remove one screw and rotate the plate to expose the desired amount of vent opening. Replace the screw to hold the door in desired location.
8. Ensure that the wall sleeve is installed squarely and is secured before installing the unit.

NOTE: *After removing the construction debris guard, check the bottom of the sleeve pan to ensure that it is sloped 1/2 bubble toward the building exterior. Ensure that the bottom of the pan and drain are clear of obstruction and operational.*



**NOTE:** *Inspect the sleeve seal, which is supplied with the sleeve, to ensure that it is properly secured and aligned (Figure. 4). Use a high grade non-hardening sealant to close any gaps that may exist between the seal and the wall of the sleeve.*

9. After the seal is inspected, lift the unit onto the base of the sleeve and slide the unit forward to engage the seal. The unit is fully engaged when the upper housing of the SPXC is 1/2 inch away from the top inside edge of the sleeve.
10. Check that the unit is completely seated on all four sides against the wall sleeve seals.

**CAUTION:** If unit is not sealed completely, water and/or outside air will infiltrate into the closet. If necessary seal any openings that may exist.

**CAUTION:** Ensure compressor bolts are torqued to no more than 30 in.lbs. prior to unit start up.

**FIGURE 5.** Filter Bracket Detail

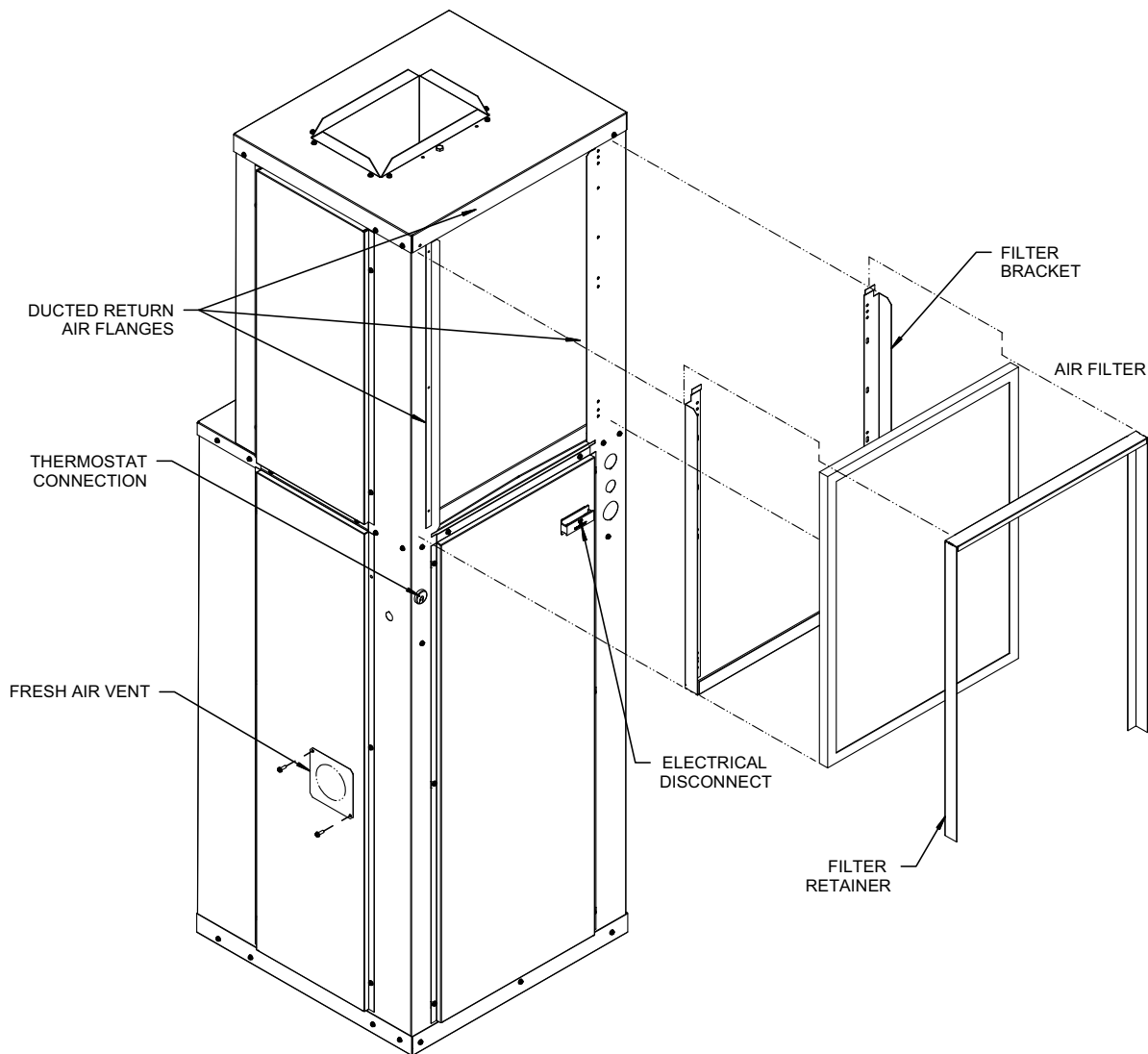

## AIR DISTRIBUTION

---

Install ductwork onto unit discharge and ensure that the connection is leak free. A flexible boot connection may be desirable to provide more noise elimination, convenient installation and removal of the SPXC unit.

All duct work must be installed in accordance with National Fire Protection Association Codes 90A and 90B. Ducts should be adequately insulated to prevent condensation during the cooling cycle and to minimize heat loss during the heating cycle. All return air must be filtered to prevent dirt buildup on the coil surface. If there is no ducted return, applicable installation codes may limit the unit to installation only in a single story residence. In many cases it is acceptable to use ducting of the same size as the fan coil connections. However, unique arrangements or long duct runs must be confirmed by a local professional. The manufacturer will not be responsible for misapplied equipment.

Supply and return duct system must be adequately sized to meet the system's air requirements and static pressure capabilities. The duct system should be insulated with a minimum of 1-inch insulation with a vapor barrier in conditioned areas or 2 inches minimum in unconditioned areas.

## ELECTRICAL

---

Install a factory approved or equivalent thermostat according to directions furnished with the thermostat. The thermostat should be located on an inside wall where it will not be affected by drafts, sunlight or any other heat producing appliances. Connect thermostat wires to the thermostat following the wiring diagram attached to the unit

**NOTE:** *SPXC Heat Pump units operate with the reversing valve energized in the HEATING mode. The thermostat must be wired or configured accordingly or the unit will not operate properly.*



**WARNINGS: Electric Shock Hazard**

- Disconnect all power supplies before servicing; lock out/tag out to prevent accidental electrical shock. Note: there may be multiple power sources.
- Use copper conductors only.
- Install all parts and panels before operating.
- Failure to follow these warnings can result in injury or death.

All wiring must comply with local and national code requirements. Any alteration of the internal wiring will void safety agency certification and manufacturer's warranty.

Nameplate data indicates the operating voltage, phase, ampacity, maximum over current protection and minimum voltage. Units must never be installed or operated where voltage exceeds the nameplate voltage by more than 10%. Failure of the compressor as a result of operation with improper voltage voids the compressor replacement warranty.

The unit comes with a factory supplied disconnect, however, the contractor is responsible for providing over current protection on the branch circuit. Refer to the unit wiring diagram for single point electrical connection.

These units are provided with a Class 2 transformer for 24-volt control circuits. Should any add-on equipment also have a Class 2 transformer furnished, care must be taken to prevent interconnecting outputs of the two transformers by using a thermostat with isolating contacts.

## PIPING

### SPXC-HW PIPING PRECAUTIONS

1. Flush all field water piping prior to connection to remove all debris.
2. Use wet cotton rags to cool valve bodies when soldering.
3. Open all valves (mid-way for hand valves, manually open on motorized valves) prior to soldering.
4. When soldering to bronze or brass, heat the piping while in the socket/cup and begin introducing the solder when the flux boils rapidly. Avoid direct flame into the solder joint.
5. Heat can only be applied to the cup of the valve body for a minimal time before damage occurs (even with the use of wet rags).
6. Avoid rapid quenching of solder joints as this will produce joints of inferior quality
7. Provisions must be made for expansion and contraction of piping systems. All horizontal and vertical risers, including runouts, must be able to withstand significant movement with temperature changes. Failure to do so will result in damage and failure of piping, fittings and valves throughout the building.
8. Never insulate the heads or motorized portion of control valves. Damage can occur in the form of excessive heat build up and interference to the operation and moving parts will result.
9. All piping made in the field should be installed with consideration of additional space for any electrical routing that may be required.
10. Connect all piping per accepted industry standards and observe all regulations governing installation of piping systems.



**CAUTION:**

Hydronic systems are not designed to hold pressurized air and should only be tested with water. Pressurizing system with air could damage equipment.

11. When all connections are complete, pressure test system. Repair any solder joint leaks and gently tighten any leaking valve packing nuts and piping accessories, as required.

### SPXC-HW PIPING INSTALLATION

These units employ a hydronic coil designed for use with hot water.

- All piping must be adequately sized to meet the design water flow requirements as specified for the specific installation. Piping must be installed in accordance with all applicable codes.
- The piping connections on the equipment are not necessarily indicative of the proper supply and return line sizes. To minimize restrictions, piping design should be kept as simple as possible.



**CAUTIONS:**

- When connecting piping to SPXC-HW unit, do not bend or reposition the coil header tubing for alignment purposes. This could cause a tubing fracture resulting in a water leak when pressure is applied to the system.
- Prior to connecting to the SPXC-HW all external piping must be purged of debris.
- It is also recommended that all piping be insulated to prevent freezing when piping is run in an unconditioned space.

NOTE: *Coil freeze protection is recommended for applications where the SPXC-HW is located in ambient air locations or within structures that may be unoccupied during freezing conditions. Consult the factory for additional information.*

**CONDENSATE DRAIN**

The SPXC is designed so that the wall sleeve is the principle drain pan. Drain tubing is factory installed which drains evaporator condensate through the bottom of the unit which then is allowed to drain into the wall sleeve pan.

Condensate drain lines must be installed with adequate slope to ensure positive drainage.

Prior to unit installation ensure that the drain is unobstructed and leak free.

NOTE: *When preparing unit for installation, check to ensure that the drain tubing from the evaporator is securely attached to the copper nipple in the pan under the compressor. The wall sleeve has a 3/4 NPT nipple located in the bottom for connection to a drain (Figure. 6). A trap may be required in the condensate drain line to prevent sewer gas from escaping into the room.*

FIGURE 6. Side View

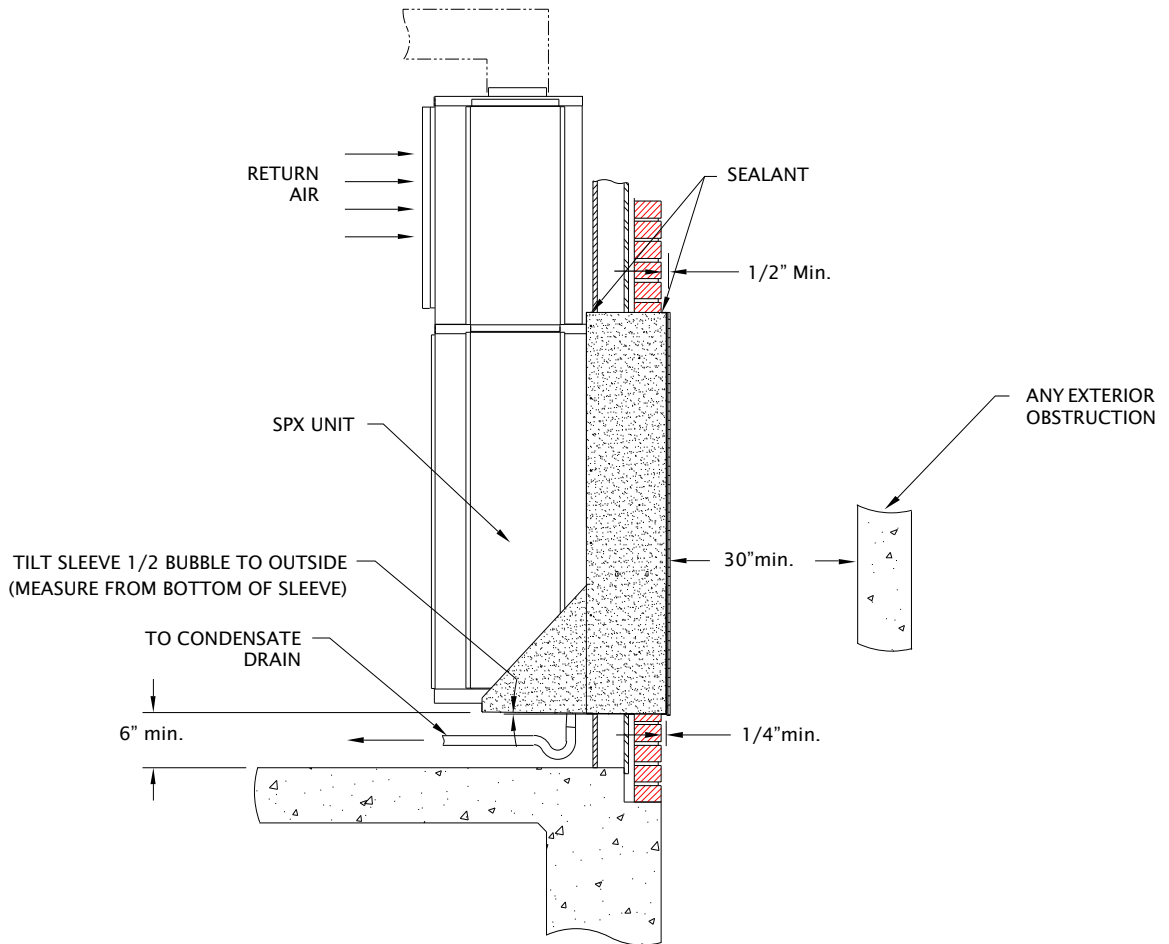

---

## AIR FILTER

---

All indoor return air must be filtered.

The preferred methods are:

1. Use the factory supplied filter kit which attaches to the inlet of the evaporator.
2. Use the filter kit supplied with the access panel which accepts a 20 inch x 20 inch x 1 inch throwaway type filter.
3. Install a filter in the return grille mounted in the wall. Any field installation of an air filter, means must be provided, for use of a disposable filter which is no smaller than the face area of the evaporator coil.

---

## SYSTEM CHECK

---

### SPXC COOLING / ELECTRIC HEAT UNITS

1. Set thermostat system switch to “Off” position and fan switch to “Auto” position. Apply power to the SPXC unit.

NOTE: *The SPXC employs a random reset timer which delays unit operation up to 60 seconds following initial power application. Electronic thermostats may also employ internal reset timers which may further delay any changes which are made to the operation of the unit.*

2. Set fan switch to “On”, indoor blower should operate after the reset timer cycle is complete.
3. Return fan switch to “Auto”, indoor blower should de-energize.
4. Set system switch to “Cool” and lower thermostat set point to coldest setting. The compressor should energize as well as the outdoor fan and indoor blower.

NOTE: *The SPXC employs a compressor short cycle delay (~6minutes) which will not allow the compressor to immediately restart following shut down. Additional delays may be experienced if using an electronic digital thermostat.*

5. Return thermostat set-point to a temperature warmer than a room temperature and the compressor and outdoor fan should de-energize. The indoor blower should remain in operation for an additional 45 seconds, then de-energize.
6. Move system switch to “Heat” and raise thermostat to a set point higher than room temperature. The indoor blower and electric heating element(s) should energize.
7. Return system switch to “Off” position.

NOTE: *The SPXC features a low ambient compressor lock out switch, which limits the refrigerant system operation when the sensor detects a temperature less than 40 degrees F in the outdoor section of the cabinet.*

**SPXC-HP  
HEAT PUMP UNITS**

1. Set thermostat system switch to “Off” position and fan switch to “Auto” position. Apply power to the SPXC-HP unit.

NOTE: *The SPXC-HP employs a random reset timer which delays unit operation up to 60 seconds following initial power application. Electronic thermostats may also employ internal reset timers which may further delay any changes which are made to the operation of the unit.*

2. Set fan switch to “On”, blower should operate after the reset timer cycle is complete.
3. Return fan switch to “Auto”, blower should de-energize.
4. Set system switch to “Cool” and lower thermostat set point to coldest setting. The compressor should energize as well as the outdoor fan and indoor blower.
5. Return thermostat set-point to a temperature warmer than room temperature and the compressor and outdoor fan should de-energize. The indoor blower should remain in operation for an additional 45 seconds, then de-energize.

NOTE: *The SPXC-HP employs a short cycle delay (~6 minutes) which will not allow the compressor to immediately restart following shut down. Additional delays may be experienced if using an electronic digital thermostat.*

6. Move system switch to “Heat” and raise thermostat to a set point slightly higher than room temperature (less than 2 degrees). The compressor, outdoor fan and indoor blower should energize.
7. Raise set point to more than 2 degrees and the electric heaters should energize. The compressor and condenser fan will immediately de-energize. The compressor will remain locked out and the electric heat operating until the thermostat satisfies.

NOTE: *The SPXC-HP employs a compressor lock out which will not allow the compressor and electric heaters to energize at the same time.*

8. Lower the set point to less than room temperature and the system should de-energize.
9. Return system switch to “Off” position.

NOTE: *The SPXC-HP features a low ambient compressor lock out switch, which limits the refrigerant system operation when the sensor detects a temperature less than 40 degrees F in the outdoor section of the cabinet.*



**WARNING:** SPXC Heat Pump units operate with the reversing valve energized in the HEATING mode. The thermostat must be wired or configured accordingly or the unit will not operate properly.

**SPXC-HW  
COOLING / HOT  
WATER UNITS**

1. Set thermostat system switch to “Off” position and fan switch to “Auto” position. Apply power to the SPXC-HW unit.

NOTE: *The SPXC-HW employs a random reset timer which delays unit operation up to 6 minutes following initial power application. Electronic thermostats may also employ internal reset timers which may further delay any changes which are made to the operation of the unit.*

2. Set fan switch to “On”, indoor blower should operate after the reset timer cycle is complete.
3. Return fan switch to “Auto”, indoor blower should de-energize.
4. Set system switch to “Cool” and lower thermostat set point to coldest setting. The compressor should energize as well as the outdoor fan and indoor blower.

NOTE: *The SPXC-HW employs a compressor short cycle delay (~6minutes) which will not allow the compressor to immediately restart following shut down. Additional delays may be experienced if using an electronic digital thermostat.*

5. Return thermostat set-point to a temperature warmer than a room temperature and the compressor and outdoor fan should de-energize. The indoor blower should remain in operation for an additional 45 seconds, then de-energize.
6. Move system switch to “Heat” and raise thermostat to a set point higher than room temperature. The indoor blower and field supplied motorized valve should energize.
7. Lower the set point to less than room temperature and the system should de-energize.
8. Return system switch to “Off” position.

NOTE: *The SPXC-HW features a low ambient compressor lock out switch, which limits the refrigerant system operation when the sensor detects a temperature less than 40 degrees F in the outdoor section of the cabinet.*

## MAINTENANCE

If servicing or major repairs are required, the complete unit can be removed as follows:

1. Disconnect the electrical power circuit supplying the unit.
2. Remove line and low voltage wiring from unit.
3. Remove rear access panel.
4. Remove supply duct from top of unit.
5. Slide unit back out of sleeve.
6. Unit may be removed from closet.

To reinstall unit, use the installation procedure outlined above.



**WARNING:** Replace all access panels before turning on main power.



**WARNING:** It is illegal to discharge refrigerant into the atmosphere. Use proper reclaiming methods and equipment when installing or servicing this unit. Service should be performed by a QUALIFIED service agency. The refrigerant system contained in the unit normally requires no maintenance since it is a closed, self-contained system.

### FAN

The fan should be inspected and cleaned annually, in conjunction with maintenance of the motor. It is important to keep the wheels clean in order to avoid imbalance and vibration.

### MOTOR

Check motor connections to ensure that they are secure and made in accordance with the wiring diagram.

The blower motor should be cleaned annually.



**WARNING:** **Units with ECM motors have line voltage power applied at all times. Make sure power is disconnected before servicing.**

### FILTER

The air filter should be cleaned or replaced every 30 days or more frequently if severe conditions exist. Always replace the filter with the same type as originally furnished.

### COIL

Any dust or other contaminants which accumulate on the heat transfer surfaces interferes with the air flow and impairs heat transfer. The coil must be kept clean by any of the following methods.

- Cleaning with low-pressure compressed air.
- Flushing or rinsing with water (a detergent is advisable for greasy surfaces).

Cleaning the outdoor coil of foreign material such as lint, dust, leaves or other obstructions as necessary.

### DRAIN PIPING

The drain should always be:

- Connected or piped to an acceptable disposal point sloped away from the unit at least 1/8-inch per foot.
- Checked before summer operation.
- Periodically checked during summer operation.

### PREVENTATIVE MAINTENANCE

To achieve maximum performance and service life of each piece of equipment, a formal schedule of regular maintenance should be established and maintained.

### MAINTENANCE UPDATES

A current copy of the Maintenance Program log can be found at [www.firstco.com](http://www.firstco.com) under "Product Information," or click [HERE](#).