

SlideLOK® Ready for Installation Coupling Fig. 74

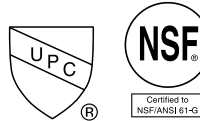

*Patented



The SlideLOK coupling is the most rigid ready for installation coupling designed to reduce installation time. The slide action eases assembly and reduces installation time. The patented gasket provides four separate sealing surfaces for added protection.

The SlideLOK coupling is designed to be used with roll groove or cut groove steel pipe, grooved light wall pipe, Gruvlok grooved-end fittings, and valves.

The SlideLOK coupling allows for pressures between full vacuum and 750 psi on roll or cut grooved carbon steel standard wall pipe. The SlideLOK coupling provides a rigid connection allowing pipe hanging practices per ASME B31 Pipe Codes.

*Patent: 8550502, 8615865, 2732427, D680629, D680630, D696751, 8282136, 9239123, 9297482, 9194516, 9297484, 9039046, 9500307

Material Specifications

Bolts
SAE J429, Grade 5, Zinc Electroplated

Heavy Hex Nuts
ASTM A563, Grade A, Zinc Electroplated

Material Specifications (continued)

Hardware Kits

304 Stainless Steel (available in sizes up to ¾")

Kit includes:

- (2) Bolts per ASTM A193, Grade B8 and
- (2) Heavy Hex Nuts per ASTM A194, Grade 8.

EcoGuard® (available in sizes up to ¾")

Kit includes:

- Bolts per SAE J429, Grade 5, with EcoGuard corrosion-resistant zinc flake coating and
- (2) Heavy Hex Nuts per ASTM A563, Grade A, EcoGuard corrosion-resistant zinc flake coating.

Housing

Ductile Iron conforming to ASTM A 536, Grade 65-45-12

Coatings

Rust inhibiting paint

Color: Orange (standard)

Hot Dipped Zinc Galvanized (optional)

Gaskets

Properties as designated in accordance with ASTM D2000

Grade "EP" EPDM (Green and Red color code)

-40°F to 250°F (Service Temperature Range)
(-40°C to 121°C)

Recommended for water service, diluted acids, alkalies solutions, oil-free air and many other chemical services.

NOT FOR USE IN PETROLEUM APPLICATIONS.

Grade "T" Nitrile (Orange color code)

-20°F to 180°F (Service Temperature Range)
(-29°C to 82°C)

Recommended for petroleum applications.

Air with oil vapors and vegetable and mineral oils.

NOT FOR USE IN HOT WATER OR HOT AIR

NOT FOR USE IN DRINKING WATER

Gasket Type

SlideLOK (2" - 8")

Lubrication

Standard

Gruvlok Xtreme



SlideLOK Pressure Responsive Gasket



PROJECT INFORMATION	APPROVAL STAMP
Project:	Approved
Address:	Approved as noted
Contractor:	Not approved
Engineer:	Remarks:
Submittal Date:	
Notes 1:	
Notes 2:	

SlideLOK® Ready for Installation Coupling Fig. 74

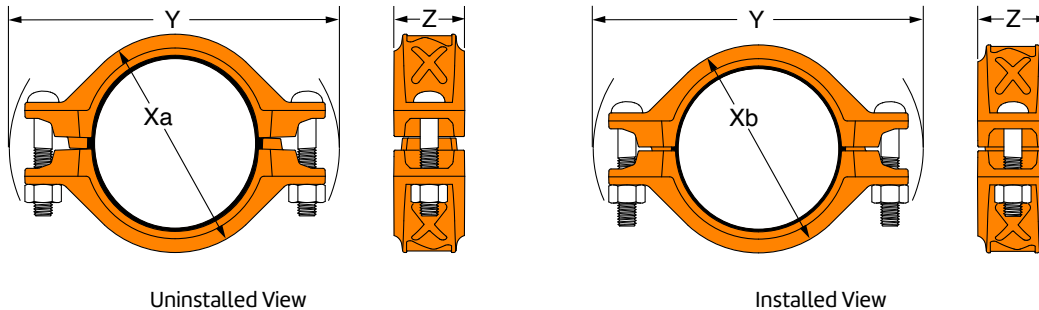

Nominal Size	O.D.	Max. Working Pressure▲	Max. End Load	Allowable Pipe End Separation	Coupling Dimensions				Coupling Bolts		Approx. Wt. Ea.
					Xa	Xb	Y	Z	Qty.	Size	
In./DN(mm)	In./mm	PSI/bar	Lbs./kN	In./mm	In./mm	In./mm	In./mm	In./mm		In./mm	Lbs./kg
2 50	2.375 60.3	750 51.7	3,323 14.78	0.13 3.18	3¾ 95	3⅜ 86	6 152	2 51	2	½ x 2¾ M12 x 70	2.9 1.3
2½ 65	2.875 73.0	750 51.7	4,869 21.66	0.13 3.18	4⅝ 117	4¼ 108	6⅜ 163	2 51	2	½ x 2¾ M12 x 70	3.1 1.4
3 80	3.500 88.9	750 51.7	7,216 32.10	0.13 3.18	5⅞ 132	4⅞ 119	7 178	2 51	2	½ x 3½ M12 x 89	3.6 1.6
4 100	4.500 114.3	750 51.7	11,928 53.06	0.20 5.08	6½ 165	6 152	8⅝ 212	2 51	2	½ x 3½ M12 x 89	4.9 2.2
5 125	5.563 141.3	750 51.7	18,229 81.09	0.20 5.08	7¼ 184	6¾ 171	10½ 267	2 51	2	⅝ x 3½ M16 x 89	5.5 2.5
6 150	6.625 168.3	700 48.3	24,130 107.34	0.20 5.08	8⅝ 211	7¾ 197	11 279	2 51	2	⅝ x 3½ M16 x 89	6.3 2.9
8 200	8.625 219.1	600 41.4	35,056 155.94	0.20 5.08	10¾ 273	10⅞ 273	14 356	2½ 64	2	¾ x 4½ M20 x 115	14.3 6.5

Notes:

Range of Pipe End Separation values are for system layout reference only. Actual installation spacing may vary based on pipe condition.
 ▲-Maximum Working Pressure Rating is for schedule 40 steel pipe. For light wall, stainless steel, aluminum and ISO pipe pressure ratings, please refer to the technical data section.
 Not for use on "EG" rolled or cut grooved pipe ends.
 For additional details see "Coupling Data Chart Notes" in the Introduction Section of the Gruvlok Catalog.
 See Installation & Assembly directions on next page.
 Not for use in copper systems.



asc-es.com

Building connections that last™

Fig. 74 SlideLOK® Ready for Installation Coupling



Read and understand all instructions before use.

WARNING

Ensure system is drained and depressurized before installation or service.

Use appropriate personal protective equipment.



Failure to follow these instructions could result in serious personal injury and/or property damage.

1 Pipe Preparation

Pipe ends are to be rolled or cut grooved according to ASC Engineered Solutions™ specifications. Not for use on “EG” rolled or cut grooved pipe ends. The pipe end must be smooth and free from metal burrs, sharp edges or projections.

2 Gasket Preparation

Ensure the gasket is suitable for the intended application by referring to the ASC gasket compatibility chart. Apply a light coating of Gruvlok® Lubricant to exposed gasket surfaces.

3 Assembly

The SlideLOK Figure 74 may be installed by one of two methods. The preferred method depends on the type of pipe components being joined and their orientation. Please review both methods before installing.

Step 3 – Method No. 1

Slide the SlideLOK coupling completely over the grooved pipe end. This will allow a clear and un-obstructed view of the pipe for correct alignment.

A. Slide the coupling on the pipe past the groove. The bolts and nuts can be hand tightened to position the coupling in place.

B. Align the mating pipe end. Align the two adjoining pipes together.

C. Slide the coupling back over the grooves so that the coupling keys are located over the respective grooves on both pipe ends.

D. Follow the instructions on fastening the coupling as shown in Step 4.



Step 3 – Method No. 2

Slide the SlideLOK coupling half way onto the pipe end or fitting. This will better accommodate fitting, and valve accessories during installation.

A. Slide the coupling on the fitting so that the groove and keys are aligned.

B. Bring the pipe end or

fitting towards the coupling and insert so that the groove and coupling keys are aligned.

C. Hand tighten the nuts to correctly position the couplings keys over the respective grooved ends.

D. Follow the instructions on fastening the coupling as shown in Step 4.



READY FOR INSTALLATION – RIGHT OUT OF THE BOX

Do not disassemble the SlideLOK Coupling. The Figure 74 coupling is ready for installation. The bolt and gasket do not need to be removed.

4 Tighten Nuts

Securely tighten nuts alternately and equally, keeping the gaps at the bolt pads evenly spaced.

Notice: Uneven tightening may cause the gasket to pinch. Gasket should not be visible between segments after bolts are tightened.

ANSI Specified Bolt Torque

Bolt Size	Wrench Size	Specified Bolt Torque*
In.	In.	Ft.-Lbs
1/2	7/8	80–100
5/8	1 1/16	100–130
3/4	1 1/2	130–180

* Non-lubricated bolt torque



5 Assembly is Complete

Visually inspect the pipe joint to assure the coupling keys are fully engaged in the pipe grooves. The bolt pads are to have equal gaps on each side of the coupling.

Notice: Visually inspect both sides of the coupling to ensure gaps between bolt pads are evenly spaced and are parallel. Any deviations must be corrected before placing coupling into service.

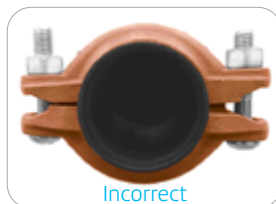

asc-es.com

Building connections that last™

Fig. 74 SlideLOK® Ready for Installation Coupling



Read and understand all instructions before use.

WARNING

Ensure system is drained and depressurized before installation or service.

Use appropriate personal protective equipment.



Failure to follow these instructions could result in serious personal injury and/or property damage.

REINSTALLATION OF THE FIGURE 74 SLIDELOK COUPLING

The SlideLOK coupling is designed to be installed in the ready for installation assembly position once. After the initial assemble the following steps are to be taken to re-install the Fig. 74 SlideLOK coupling.

1 De-Pressurize the System

De-pressurize the system before removing the SlideLOK Coupling. Dis-assemble the couplings by removing the nuts, bolts and gasket from the housing halves. A wrench is required to overcome the epoxy used to secure the nuts on the bolts.

2 Pipe Preparation

Pipe ends are to be rolled or cut grooved according to ASC Engineered Solutions™ specifications. Not for use on “EG” rolled or cut grooved pipe ends. The pipe end must be smooth and free from metal burrs, sharp edges or projections.



3 Gasket Preparation

Ensure the gasket is suitable for the intended application by referring to the Anvil gasket compatibility chart. A light coating of Gruvlok® lubricant must be applied to the gasket prior to installation.



4 Pipe Alignment and Gasket Installation

Slide the gasket onto the pipe then align the two pipe ends together. Pull the gasket into position, centering it between the grooves on each pipe. Gasket should not extend into the groove on either pipe.

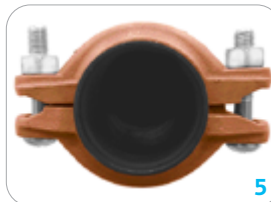

5 Housing Assembly

Place each housing halves on the pipe making sure the housing key fits into the groove. Be sure that the tongue and recess portions of the housing mate properly. Insert the bolts.

6 Tighten Nuts

Securely tighten nuts alternately and equally, keeping the gaps at the bolt pads evenly spaced.

ANSI Specified Bolt Torque		
Bolt Size	Wrench Size	Specified Bolt Torque*
In.	In.	Ft.-Lbs
1/2	7/8	80-100
5/8	1 1/16	100-130
3/4	1 1/2	130-180

* Non-lubricated bolt torque.

Notice: Uneven tightening may cause the gasket to pinch. Gasket should not be visible between segments after bolts are tightened.

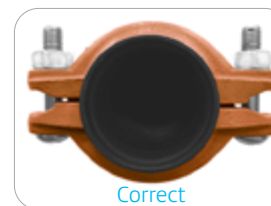

7 Assembly is Complete

Visually inspect the pipe joint to assure the coupling keys are fully engaged in the pipe grooves. The bolt pads are to have equal gaps on each side of the coupling.



Notice: Visually inspect both sides of the coupling to ensure gaps between bolt pads are evenly spaced and are parallel. Any deviations must be corrected before placing coupling into service.



asc-es.com

Building connections that last™