

FAILURE TO READ AND FOLLOW ALL INSTRUCTIONS CAREFULLY BEFORE INSTALLING OR OPERATING THIS CONTROL COULD CAUSE PERSONAL INJURY AND/OR PROPERTY DAMAGE.

PARTS INCLUDED

- 1 – 790-843A1 Flame Sensor
- 30” lead wire with ¼” quick-connect terminals
- 2 – ½” Sheet Metal Mounting Screws
- 1 – Protective Sleeve
- 1 – 3/16” quick-connect terminal
- 1 – Installation Instructions

DESCRIPTION

The 790-843A1 is an aftermarket universal flame sensor replacement for many different applications. Flame sensors in furnaces, ovens, water heaters, boilers and other applications can be replaced with the 790-843A1.

This high temperature and durable flame rod can be bent, cut or a combination of the two without losing any performance capability when the protective sleeve is placed over the rod during modification. For detailed instructions, please see pages 2, 3 and 4.

SPECIFICATIONS

ELECTRICAL RATINGS:

Insulation Resistance from Rod to Bracket:

Must be 500 megaohms at minimum

Ceramic Material:

Alumina 95% or better

Bracket Material:

Zinc plated steel or stainless steel

Agency:

CSA Certified

NOTE: Internal wires to ignitor connections to withstand operational temperature of 482 °F (250 °C).

Table of Contents	Page
Cross Reference Table & Flame Rod Bend Action	2 & 3
<i>Flame Rod Cutting Instructions</i>	2
<i>Flame Rod Bending Instructions</i>	3
Flame Rod Angle Guide	4

⚠ CAUTION



Shock Hazard

- Always turn off electric power before working on any appliance.
- Ensure proper connection to all wires.



Explosion Hazard

- Shut off gas to appliance before installation, and do not reconnect until installation is complete.



Fire Hazard

- Ensure that components do not come into direct contact with water (spray, dripping water or rain)
- Improper and dangerous operation can result from wiring errors.
- Ensure that wiring is routed securely, and away from any flame.

Table 1: **Cross Reference Table, Bend Angles and Modification Instructions**

NO CHANGE REQUIRED				CUTTING OF ROD REQUIRED			
Part Number	OEM	Bend °	Mod.	Part Number	OEM	Bend °	Mod.
26300	Nieco	0	N	31331	Blodgett	0	C
51585	Peerless	0	N	1380679	ICP	0	C
156501	Groen	0	N	1380687	ICP	0	C
195292	Reznor	0	N	24376701	ICP	0	C
903600	Nordyne	0	N	90439300	Roberts Gordon	0	C
100109908	AO Smith	0	N	100097250**	AO Smith	0	C
100109966	AO Smith	0	N	01-1000V9-00151	Baxter	0	C
100110707	AO Smith	0	N	01-1000V9-00169	Baxter	0	C
100110905	AO Smith	0	N	0130F00010	Goodman	0	C
9004520215	AO Smith	0	N	025-25434-700	York	0	C
9006106205	AO Smith	0	N	025-27773-700	York	0	C
00-855392	Vulcan	0	N	025-30788-700	York	0	C
0P-496288	Stero	0	N	2536314000	York	0	C
10050-00042	Vanguard Technology	0	N	025-37499-000	York	0	C
10-760	Robertshaw	0	N	12L09	Lennox	0	C
44-1340	All Points	0	N	20-5045	AP PuraFire	0	C
52W29	Lennox	0	N	5H0750310000	Modine	0	C
760-401	White-Rodgers	0	N	5H75031	Modine	0	C
98M87	Lennox	0	N	62-23543-05	Rheem	0	C
C6437502	Goodman	0	N	632484R	Nordyne	0	C
FLS013*	Supco	0	N	83L72	Lennox	0	C
FLS401	Supco	0	N	b1172606	Goodman	0	C
FLS52W29	Supco	0	N	B11726-06	Goodman	0	C
FLS700	Supco	0	N	FLS010	Supco	0	C
LH33WZ514*, 516*	Carrier	0	N	J38R06890-003	Sterling	0	C
LH680013*	Carrier	0	N	R46895-001	Armstrong	0	C
P496037	Stero	0	N	RZ147165	Reznor	0	C
P49-6037	Stero	0	N	S1-02527773700	York	0	C
P496288	Stero	0	N	S1-02530788700	York	0	C
PFS013*, 401, 700	Packard	0	N	S1-02532661002	York	0	C
PFS802	Packard	0	N	S1-02537499000	York	0	C
R44745-001	Armstrong	0	N	SP12144	Rheem	0	C
RZ195292	Reznor	0	N	83L72	Lennox	0	C
LB-74940A	Lennox	0	N	R45708-002	Lennox	0	C
31L71	Lennox	0	N	2527773700	York	0	C

*Requires extra connector

**Requires extra heat sleeve

If extra connector or heat sleeve is required, re-use from existing application.

Cutting Instructions

1. Place protective sleeve over **new** 790-843A1 flame rod, flush with the ceramic
2. Cut **new** 790-843A1 flame rod to match length of **old** flame rod being replaced

Use side cutters or hacksaw when cutting flame rod

Table 1: **Cross Reference Table, Bend Angles and Modification Instructions**

BENDING OF ROD REQUIRED				BENDING AND CUTTING REQUIRED			
Part Number	OEM	Bend °	Mod.	Part Number	OEM	Bend °	Mod.
64356	Middleby	90	B	25957	Nieco	2 Bends	PC
69854	Middleby	90	B	10735201	Goodman	90	PC
1172827, 6920*, 9161*	ICP	73	B	2530801000	York	90	PC
1184322*	ICP	73	B	025-30801-000	York	90	PC
1190383*	ICP	73	B	760-802	White-Rodgers	90	PC
20467102	Lennox	90	B	LH33WZ518	Carrier	35	PC
100112678**	Lochinvar	60	B	M9517	Middleby	90	PC
100165921	Lochinvar	28	B	S1-02530801000	York	90	PC
00-851223	Vulcan	2 Bends	B	S1-02530802000	York	90	PC
00-947498	Vulcan	45	B	S1-02535306000	York	90	PC
025-35354-000	York	90	B	<div style="background-color: #e6f2ff; padding: 5px; margin-bottom: 10px;"> <p style="text-align: center; margin: 0;">Bending Instructions</p> <ol style="list-style-type: none"> 1. Match flange on the new 790-843A1 with flange on old flame sensor being replaced <ol style="list-style-type: none"> a. Note on the new 790-843A1 where the rod bend should begin – denoted the ‘beginning of bend’ or ‘fulcrum’ 2. Place protective sleeve over new flame rod, flush with ceramic 3. Place new 790-843A1 on a sturdy, flat surface (table is recommended) with fulcrum positioned on the edge of the surface (see Fig.1 on page 4) <ol style="list-style-type: none"> a. IMPORTANT: ensure the rotation of the flange matches flange on old flame sensor (see 1a) 4. While securing new 790-843A1 in place with the fulcrum on the edge, press down on the tip of flame rod until the proper bend angle is achieved <ol style="list-style-type: none"> a. CAUTION: when pressing down, place a protective material between hand and sensor tip to avoid injury to hand b. See Fig. 2 on page 4 to match correct bend angle </div> <div style="background-color: #fff9c4; padding: 5px; margin-bottom: 10px;"> <p style="text-align: center; margin: 0;">Bend and Cut Instructions</p> </div> <p>Follow the instructions outlined above for bending, then cut the new 790-843A1 flame rod tip to match length of old flame sensor being replaced.</p> <p>Use side cutters or hacksaw when cutting flame rod</p>			
10-681	Robertshaw	73	B				
2702-311P	York	90	B				
28M97, 9701	Lennox	90	B				
44L48	Lennox	90	B				
49M84	Lennox	90	B				
52M72	Lennox	90	B				
62-23543-01, 02, 06, 08	Rheem	90	B				
FLS014	Supco	73	B				
FLS201, 301	Supco	90	B				
LH33WZ511*, 515*	Carrier	73	B				
LH33WZ520*	Carrier	73	B				
LH33WZ521*	Carrier	73	B				
LH680012*	Carrier	73	B				
LH680014*	Carrier	73	B				
LH680534*	Carrier	73	B				
PFS014	Packard	73	B				
PFS301	Packard	90	B				
S1-02535354000	York	90	B				
S1-2702-311P	York	90	B				
S1-2845-3111	York	45	B				
SEN01114, 1114	Trane	90	B				

*Requires extra connector

**Requires extra heat sleeve

If extra connector or heat sleeve is required, re-use from existing application.



For complete cross reference information please visit Emerson.com/White-Rodgers or download the **WR Mobile App**.

Place 790-843A1 on flat surface with flange rotation matching old flame sensor being replaced. Place fulcrum on **corner edge of surface**, **secure ceramic to surface** and **apply downward pressure on tip of rod**.

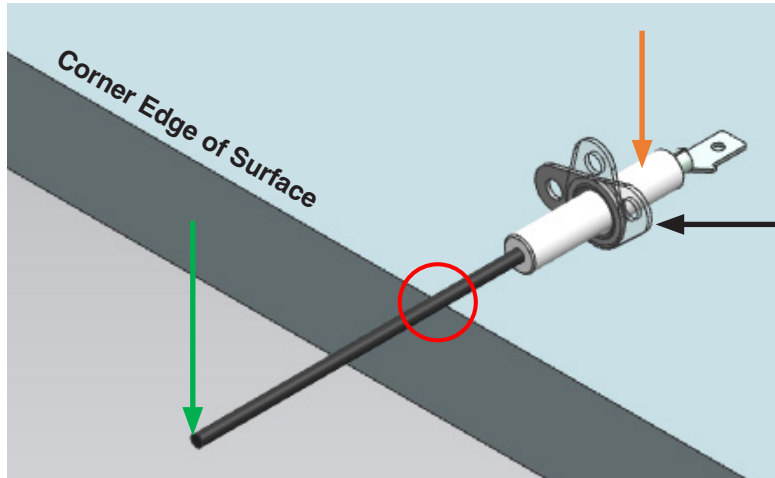

Flange could be positioned in a variety of ways, need to check old flame sensor being replaced to match flange rotation **before** bending 790-843A1.

****Make certain protective sleeve is placed over flame rod before bending or cutting rod****

Fig. 1: Flame Sensor Bending Direction

Flame Sensor Bending Guide – Match Correct Angle

To accurately detect bend angle:

1. Align ceramic portion of flame rod parallel to 0° bend line.
2. Place beginning of rod bend in center of red circle.
3. Follow °bend line of bent flame rod for correct angle.

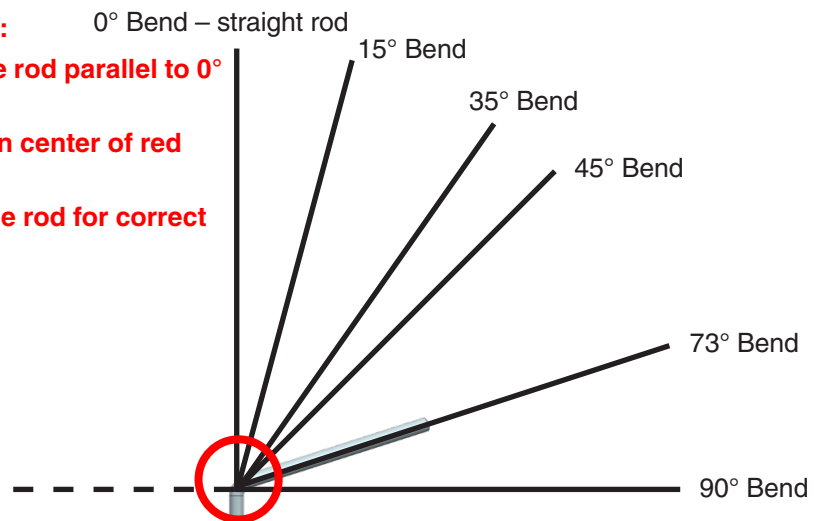

Fig. 2: Flame Sensor Bending Angle Guide

Example matching Carrier LH680534

Note: When cutting flame rod, use side cutters or hacksaw.



TECHNICAL SUPPORT: 1-888-725-9797