

GUNTHER PRESSURE BALANCE SHOWER VALVE TRIM

SKU: 953081
Code: SHGU8010



FEATURES

Required for Installation: Rough-in valve: SH4001

ASME A112.18.1/CSA B125.1, ASSE 1016 Type P, Massachusetts Accepted, LISTED ID: SH4001, SHGU8010XX



ADDITIONAL FEATURES

- Metal Handle.
- Optional Rough-in Valve:
 - Pressure balance valve with integral stops.
 - One-piece cartridge design for ease of maintenance.
 - Back-to-back capability.
 - Ceramic disc valve cartridge.
 - Cast bronze valve body.
 - Adjustable temperature limit stop.
 - Quick remove plaster guard.
 - Easy mounting brackets.

REVISED 5/30/2024

GUNTHER PRESSURE BALANCE SHOWER VALVE TRIM

SKU: 953081
Code: SHGU8010

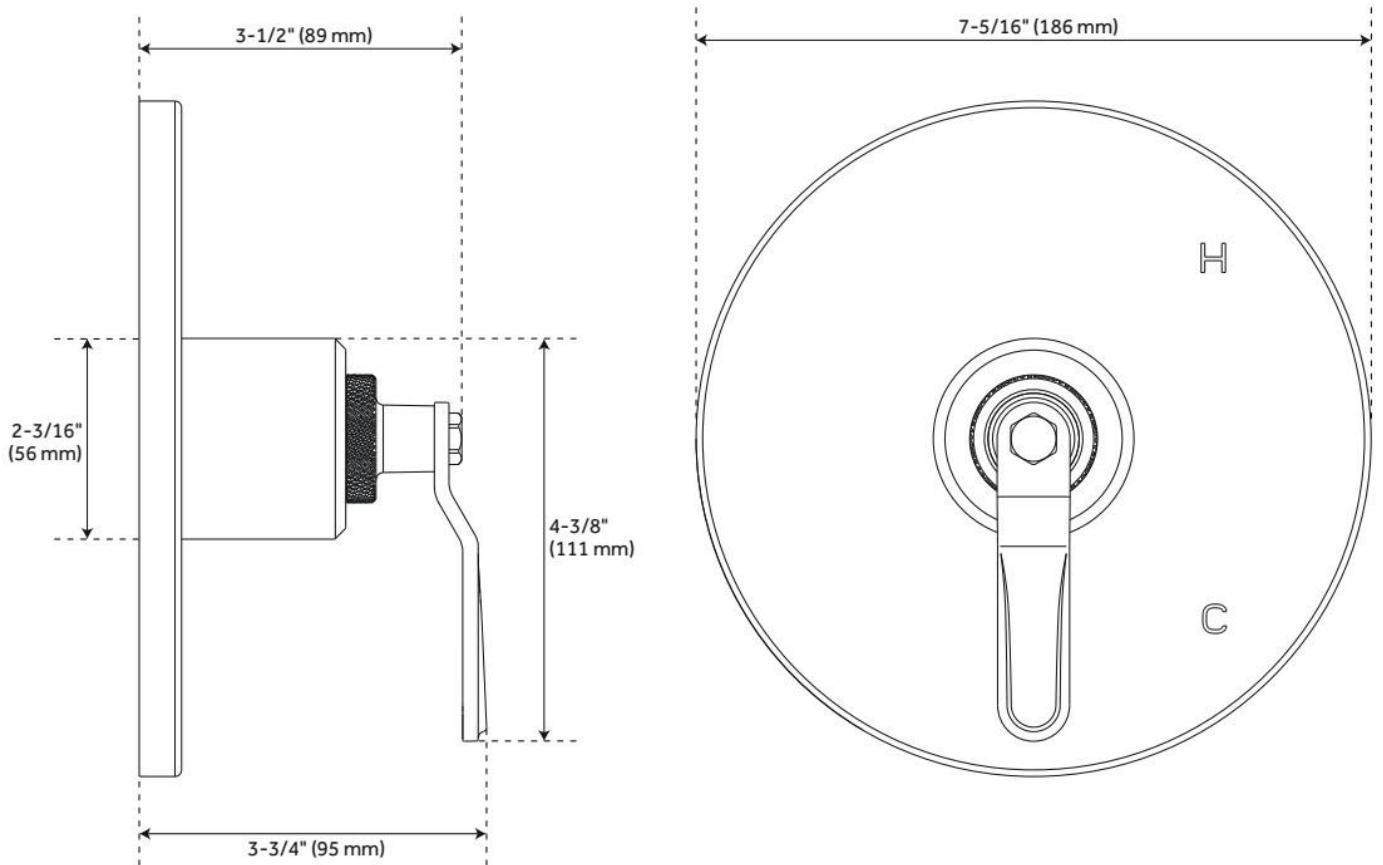

REVISED 5/30/2024

PRESSURE BALANCE TUB & SHOWER ROUGH-IN VALVE

SKU: 446520
Code: SH4001



FEATURES

Material: Brass
Flow Rate: 6.34 gpm (24.0 L/min) @ 80 psi
Connection Type: 1/2" MIP and SWT
Cartridge Type: Ceramic Disc

IAPMO, ASME A112.18.1/CSA B125.1, ASSE 1016 Type P, Massachusetts Accepted, LISTED ID: SH4001



ADDITIONAL FEATURES

- Pressure balance valve with integral stops.
- One-piece ceramic cartridge design for ease of maintenance.
- Back-to-back capability
- Adjustable temperature limit stop.
- Quick remove plaster guard and easy mounting brackets.

REVISED 11/27/2024

PRESSURE BALANCE TUB & SHOWER ROUGH-IN VALVE

SKU: 446520
Code: SH4001

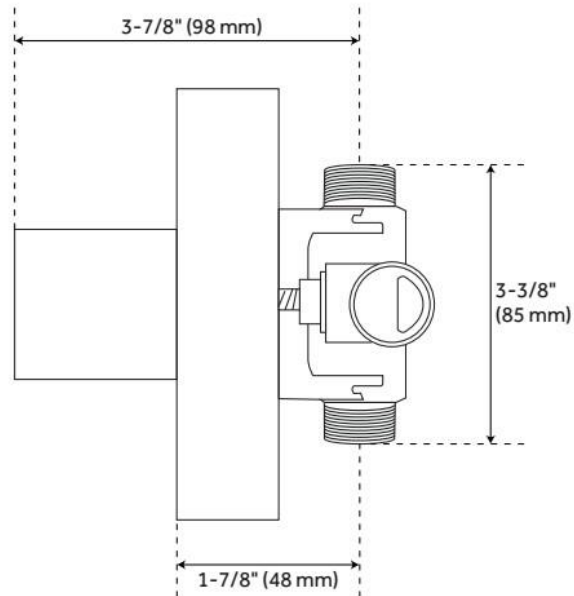
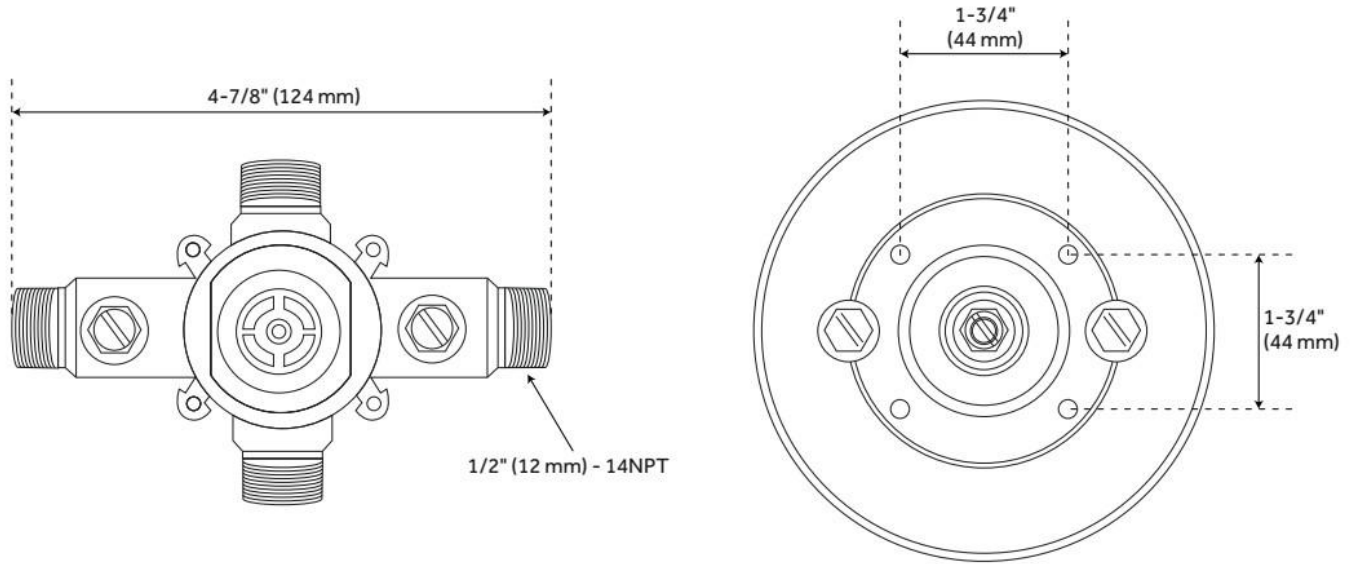

REVISED 11/27/2024