

MSY-GS36NA & MUY-GS36NA
36,000 BTU/H WALL-MOUNTED INDOOR UNIT
36,000 BTU/H COOLING ONLY OUTDOOR UNIT



Job Name:

System Reference:

Date:



Indoor Unit.....MSY-GS36NA

Outdoor Unit.....MUY-GS36NA

INDOOR UNIT FEATURES

- Dual Barrier Coating
- Slim wall-mounted indoor units provide zone comfort control
- The outdoor unit powers the indoor unit, and should a power outage occur, the system is automatically restarted when power returns
- Multiple fan speed options: Low, Medium, High, Super High
- Multiple control options available:
 - Hand-held Remote Controller (provided with unit)
 - kumo cloud® smart device app for remote access
 - Third-party interface options
 - Wired or wireless controllers
- Hot-Start Technology: no cold air rush at equipment startup or when restarting after defrost cycle
- Powerful Operation: quickly cools or heats the room by automatically adjusting fan speed and set temperature for 15 minutes
- Smart Set: recalls a preferred preset temperature setting at the touch of a button
- Wide Vane mode provides 150° of airflow

*Auto and Powerful modes available in addition to the four fan speeds

OUTDOOR UNIT FEATURES

- Dual Barrier Coating
- Slim wall-mounted indoor units provide zone comfort control
- The outdoor unit powers the indoor unit, and should a power outage occur, the system is automatically restarted when power returns
- Multiple fan speed options: Low, Medium, High, Super High
- Multiple control options available:
 - Hand-held Remote Controller (provided with unit)
 - kumo cloud® smart device app for remote access
 - Third-party interface options
 - Wired or wireless controllers
- Hot-Start Technology: no cold air rush at equipment startup or when restarting after defrost cycle
- Powerful Operation: quickly cools or heats the room by automatically adjusting fan speed and set temperature for 15 minutes
- Smart Set: recalls a preferred preset temperature setting at the touch of a button
- Wide Vane mode provides 150° of airflow

*Auto and Powerful modes available in addition to the four fan speeds

SPECIFICATIONS: MSY-GS36NA & MUY-GS36NA

Cooling at 95°F ¹	Maximum Capacity	BTU/H	33,200
	Rated Capacity	BTU/H	33,200
	Minimum Capacity	BTU/H	10,300
	Maximum Power Input	W	3,770
	Rated Power Input	W	3,770
	Moisture Removal	Pints/h	9.3
	Sensible Heat Factor		0.69
Efficiency	Power Factor [208V / 230V]	%	98.0 / 99.0
	SEER SEER2		16.2 18.5
	EER ¹ EER2 ¹		8.8 8.8
Electrical	ENERGY STAR® Certified		No
	Voltage, Phase, Frequency		208/230, 1, 60
	Guaranteed Voltage Range	V AC	187 - 253
	Voltage: Indoor - Outdoor, S1-S2	V AC	208/230
	Voltage: Indoor - Outdoor, S2-S3	V DC	24
	Short-circuit Current Rating [SCCR]	kA	5
	Recommended Fuse/Breaker Size (Outdoor)	A	20
	Recommended Wire Size [Indoor - Outdoor]	AWG	14
	Power Supply		Indoor unit is powered by the outdoor unit
	Indoor Unit	MCA	A
Fan Motor Full Load Amperage		A	0.76
Fan Motor Type			DC Motor
Airflow Rate at Cooling, Dry		CFM	374-602-699-915
Airflow Rate at Cooling, Wet		CFM	374-602-699-915
Sound Pressure Level [Cooling]		dB[A]	32-42-49-53
Drain Pipe Size		In. [mm]	5/8 [15.88]
Coating on Heat Exchanger			Dual Barrier Coating
External Finish Color			Munsell 1.0Y 9.2/0.2 White
Unit Dimensions		W x D x H: In. [mm]	46-1/16 x 11-5/8 x 14-3/8 [1,170 x 295 x 365]
Package Dimensions		W x D x H: In. [mm]	51 x 18-1/2 x 14-1/4 [1,300 x 470 x 360]
Unit Weight		Lbs. [kg]	45 [20]
Package Weight		Lbs. [kg]	51 [22.9]
Indoor Unit Operating Temperature Range	Cooling Intake Air Temp [Maximum / Minimum]*	°F	90 DB, 73 WB / 67 DB, 57 WB
Outdoor Unit	MCA	A	19.0
	MOCP	A	20
	Fan Motor Full Load Amperage	A	0.93
	Fan Motor Output	W	50
	Airflow Rate [Cooling / Heating]	CFM	2191
	Refrigerant Control		LEV
	Coating on Heat Exchanger		Blue Fin Coating
	Sound Pressure Level, Cooling ¹	dB(A)	56
	Compressor Type		Twin Rotary
	Compressor Model		SNB220FQAM1T
	Compressor Rated Load Amps	A	13.8
	Compressor Locked Rotor Amps	A	17.3
	External Finish Color		Munsell 3Y 7.8/1/1
	Base Pan Heater		N/A
	Unit Dimensions	W x D x H: In. [mm]	33-1/16 x 13 x 34-5/8 [840 x 330 x 880]
Package Dimensions	W x D x H: In. [mm]	38-3/4 x 16-3/4 x 39 [980 x 420 x 990]	
Unit Weight	Lbs. [kg]	121 [55.0]	
Package Weight	Lbs. [kg]	138 [62.5]	
Outdoor Unit Operating Temperature Range	Cooling Air Temp [Maximum / Minimum]*	°F	115 DB / 14 DB
	Cooling Thermal Lock-out / Re-start Temperatures**	°F	4 / 0
Refrigerant	Type		R410A
	Maximum Charge Quantity	Lbs, oz	4.0, 16.0
	Initial Charge Quantity	Ft. [m]	25.0 [7.5]
	Additional Refrigerant Charge Per Additional Piping Length	oz./Ft. [g/m]	.216 [20]
Piping	Gas Pipe Size O.D. [Flared]	In.[mm]	5/8 [15.88]
	Liquid Pipe Size O.D. [Flared]	In.[mm]	1/4 [6.35]
	Maximum Piping Length	Ft. [m]	100 [30]
	Maximum Height Difference	Ft. [m]	50 [15]
	Maximum Number of Bends		10

NOTES:

AHRI Rated Conditions

(Rated data is determined at a fixed compressor speed)

¹Cooling (Indoor // Outdoor)

²Heating at 47°F (Indoor // Outdoor)

³Heating at 17°F (Indoor // Outdoor)

°F 80 DB, 67 WB // 95 DB, 75 WB

°F 70 DB, 60 WB // 47 DB, 43 WB

°F 70 DB, 60 WB // 17 DB, 15 WB

*Indoor/Outdoor Unit Operating Temperature Range (Cooling Air Temp [Maximum / Minimum]):

• Applications should be restricted to comfort cooling only; equipment cooling applications are not recommended for low ambient temperature conditions.

**Outdoor Unit Operating Temperature Range (Cooling Thermal Lock-out / Re-start Temperatures):

• System cuts out in heating mode to avoid thermistor error and automatically restarts at these temperatures.

INDOOR UNIT ACCESSORIES: MSY-GS36NA

Control Interface	BACnet® and Modbus® Interface	PAC-UKPRC001-CN-1
	IT Extender	PAC-WHS01IE-E
	kumo station® for kumo cloud®	PAC-WHS01HC-E
	System Control Interface	MAC-334IF-E
	Thermostat Interface	PAC-US445CN-1
	USNAP Adapter	PAC-WHS01UP-E
	Wireless Interface for kumo cloud®	PAC-USWHS002-WF-2
Remote Sensor	Wired Remote Sensor	M21EAA307
	Wireless temperature and humidity sensor for kumo cloud®	PAC-USWHS003-TH-1
Wired Remote Controller	Deluxe Wired MA Remote Controller†	PAR-40MAAU
	Simple MA Remote Controller†	PAC-YT53CRAU-J
	Touch MA Controller†	PAR-CT01MAU-SB
Wireless Remote Controller	kumo touch™ RedLINK™ Wireless Controller	MHK2
	Lockdown bracket for remote controller	RCMKP1CB
Condensate	Blue Diamond (Advanced) Mini Condensate Pump w/ Reservoir & Sensor (208/230V) [recommended]	X87-721
	Blue Diamond (MegaBlue Advanced) Condensate Pump w/ Reservoir & Sensor	X87-835
	Blue Diamond Alarm Extension Cable — 6.5 Ft.	C13-192
	Blue Diamond MultiTank — collection tank for use with multiple pumps	C21-014
	Blue Diamond Sensor Extension Cable — 15 Ft.	C13-103
	Drain Pan Level Sensor/Control	SS610E
	Refco Condensate Pump (100-240 VAC)	GOBI-II
	Refco Condensate Pump (100-240 VAC) up to 120,000 BTU/H	COMBI
	Sauermann Condensate Pump	SI30-230
Disconnect Switch	(30A/600V/UL) [fits 2" X 4" utility box] - Black	TAZ-MS303
	(30A/600V/UL) [fits 2" X 4" utility box] - White	TAZ-MS303W
Lineset	100' x 1/4" x 100' x 5/8" Lineset (Twin-Tube Insulation)	MLS145812T-100
	15' x 1/4" x 15' x 5/8" Lineset (Twin-Tube Insulation)	MLS145812T-15
	30' x 1/4" x 30' x 5/8" Lineset (Twin-Tube Insulation)	MLS145812T-30
	50' x 1/4" x 50' x 5/8" Lineset (Twin-Tube Insulation)	MLS145812T-50
	65' x 1/4" x 65' x 5/8" Lineset (Twin-Tube Insulation)	MLS145812T-65

NOTES:

†Requires MAC-334IF-E

- M-Series EZ FIT® Recessed Ceiling Cassette, Floor-mount and Wall-mount
Allows indoor units to connect to an MA Controller:
 - Deluxe MA Remote Controller
 - Simple MA Controller
 - Touch MA Controller

OUTDOOR UNIT ACCESSORIES: MUY-GS36NA

Air Outlet Guide	Air Outlet Guide	MAC-890SG-E
Condensate	Refco Condensate Pump (100-240 VAC) up to 120,000 BTU/H	COMBI
Control/Service Tool	M- & P-Series Maintenance Tool Cable Set	M21EC0397
	USB/UART Conversion Cable (Required for all laptop connection)	M21EC1397
Drain Socket	Drain Socket	MAC-871DS
Hail Guards	Hail Guard	HG-A7
Mini-Split Wire	14 Gauge, 4 wire MiniSplit Cable—250 ft. roll	SW144-250
	14 Gauge, 4 wire MiniSplit Cable—50 ft. roll	SW144-50
	16 Gauge, 4 wire MiniSplit Cable—250 ft. roll	SW164-250
	16 Gauge, 4 wire MiniSplit Cable—50 ft. roll	SW164-50
Mounting Pad	Condensing Unit Mounting Pad: 16" x 36" x 3"	ULTRILITE1
	Outdoor Unit 3-1/4 inch Mounting Base (Pair) - Plastic	DSD-400P
Stand	18" Single Fan Stand	QSMS1801M
	24" Single Fan Stand	QSMS2401M
	Condenser Wall Bracket	QSWB2000M-1
	Condenser Wall Bracket - Stainless Steel Finish	QSWBSS
	Outdoor Unit Stand — 12" High	QSMS1201M

INDOOR UNIT DIMENSIONS: MSY-GS36NA

Unit : inch

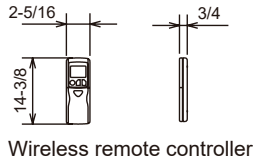
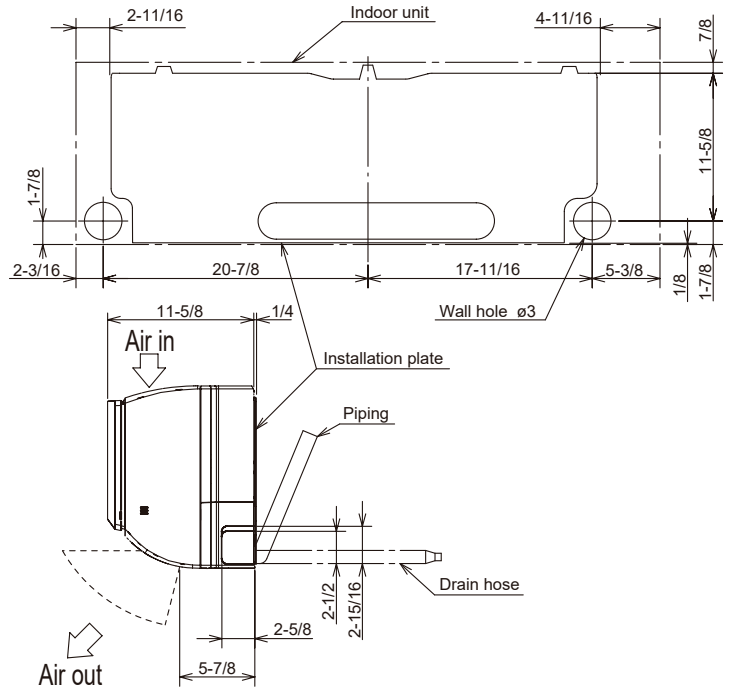
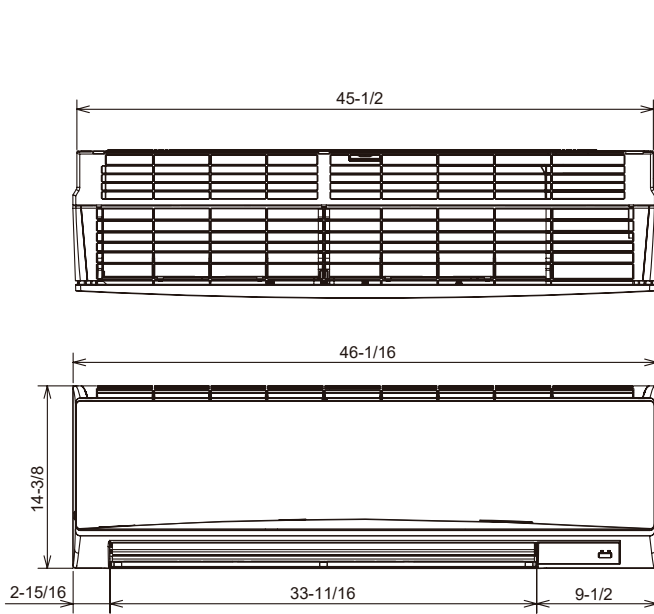

	PIPING	INSULATION
LIQUID LINE	$\phi 3/8 - 19 - 11/16$ (FLARED CONNECTION $\phi 1/4$)	$\phi 1 - 1/4$ O.D $\phi 9/16$ I.D
GAS LINE	$\phi 15/32 - 17 - 13/16$ (FLARED CONNECTION $\phi 5/8$)	$\phi 1 - 7/16$ O.D $\phi 13/16$ I.D
DRAIN HOSE	INSULATION $\phi 1 - 1/8$ CONNECTED PART $\phi 5/8$ O.D	

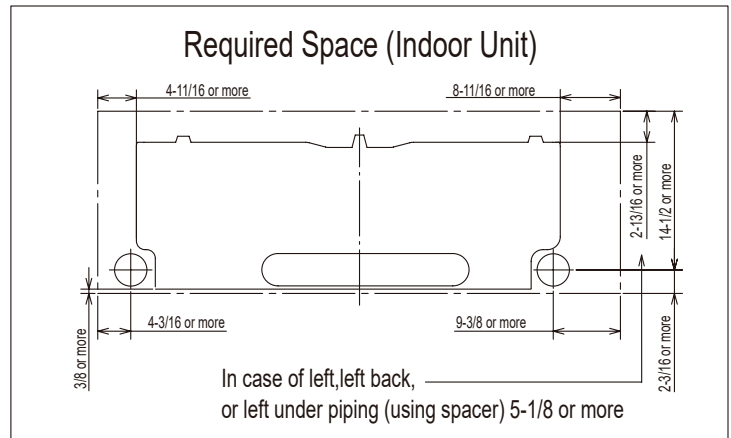

OUTDOOR UNIT DIMENSIONS: MUY-GS36NA

Unit: inch

REQUIRED SPACE

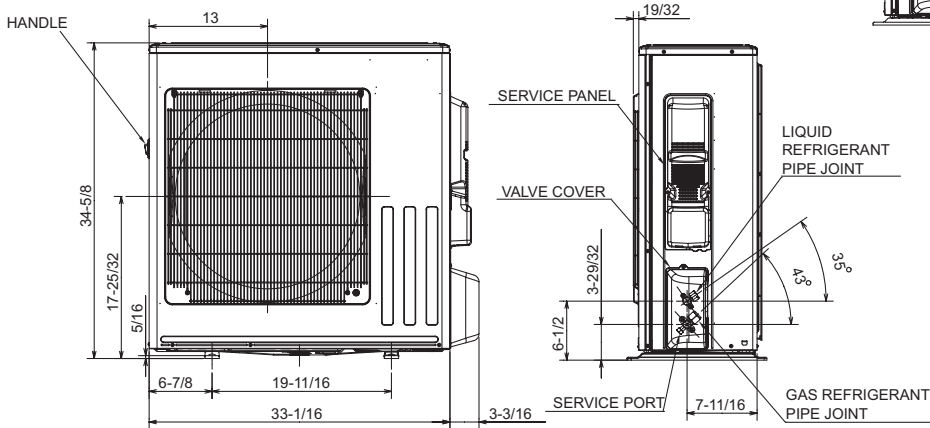
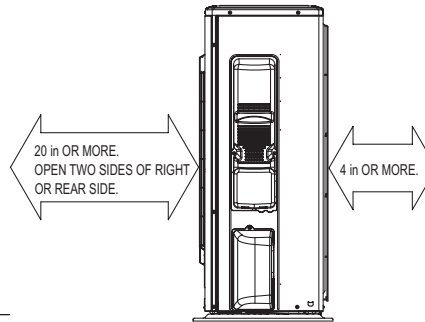
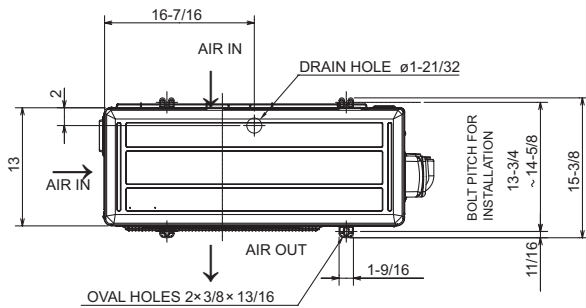
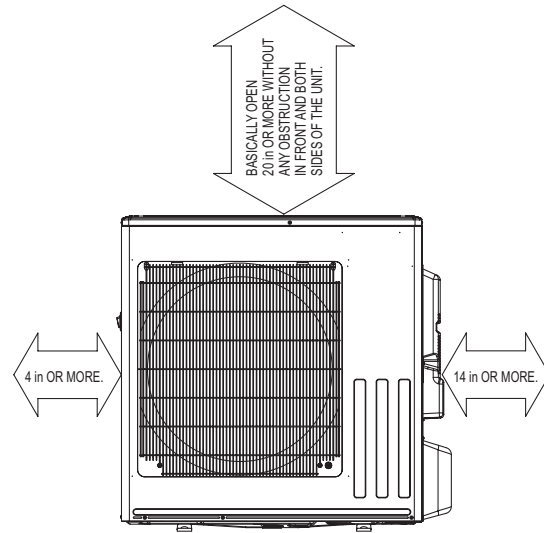

REFRIGERANT PIPE JOINT	LIQUID REFRIGERANT PPE	FLARED ø6.35 (1/4")
	GAS REFRIGERANT PPE	FLARED ø15.88 (5/8")

1340 Satellite Boulevard Suwanee, GA 30024
Toll Free: 800-433-4822 www.mehvac.com

FORM# MSY-GS36NA & MUY-GS36NA - 202303

