

Specification Sheet

525.090.110 S P-TRAP 87.5°

- Diameter: Ø110mm
- Water seal height = 89mm
- Stainless steel: AISI316L/EN1.4404

Product Codes

EAN: 5705499101485
VVS Number: 160381410
RSK Number: 1550347
NRF Number: 3395043
LVI Number: 3304021

Specification

All HygienicPro Products: Yes

Angle (°): 87.5

BimUrl_revit: <https://www.bimstore.co/products/europipe-complete-system>

Brand: BLÜCHER

Description (Marketing): P-TRAP 87.5°
-Diameter: Ø110mm
-Water seal height = 89mm
-Stainless steel: AISI316L/EN1.4404

EAN: 5705499101485

Field of Application: Domestic|Industrial

Length (mm): 132

LVI Number: 3304021

Material: AISI 316L

Material (EN): EN 1.4404

Max Flow (l/s): 10.4

Minimum Flow (l/s): 3.4

Model Number: P-TRAP 87.5° - (525.090.110 S)

NRF Number: 3395043

Outlet dia. (Inch): 4

Outlet Diameter (mm): 110

RSK Number: 1550347

Search category: Floor drains/Marine drains/Pipes and fittings

Series: Water trap-p

Type: Traps

VVS Number: 160381410

Water Seal Height (mm): 89

Weight (kg): 1,49

Weight (lbs): 3,28

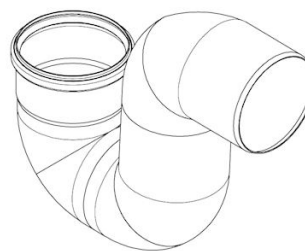
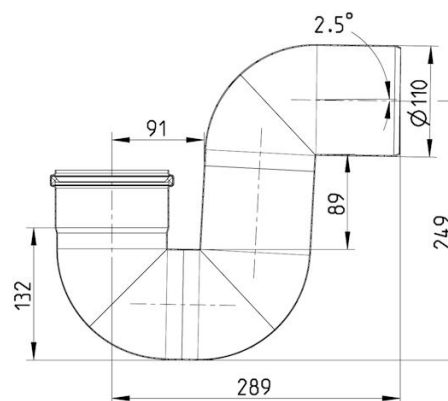

Approvals



AUS - HACCP Region 1



AUS - WMKT00204 - 22C

BLÜCHER®

Specification Sheet

Approvals

 DK - VA 2.41/19631-22

 EU - HACCP Region 4

 NO - 0692-22

 US - IAPMO File No.3247-19

ABS - LD1716353-PDA

Bureau Veritas - 03456-H0

Bureau Veritas, 02375-I0

DNV - TAP0000023-rev3

KR - Type Approval CPH42135-PE001

Lloyds Register LR22419510TA

MARINE - R4547 NATO CODIFICATION SYSTEM

PL - Hygienic Certificate - All Products

RS - 22.10017.262

BLÜCHER[®]