

Miele

W1 Washing Machine

W1 Washing Machine

WWH 860 WCS TDos&IntenseWash&WiFiConn@ct,

WWH 660 WCS TDos&WiFiConn@ct,

WWF 060 WCS WiFiConn@ct

WWB 020 WCS



W1 Washing Machine

SPECIFICATIONS	
Unit Width	23 ¹ / ₂ " (596 mm)
Unit Height	33 ¹ / ₂ " - 34 ³ / ₄ " (850 - 882 mm)
Unit Depth- Excluding Door Dimension	23 ⁵ / ₈ " (600 mm)
Unit Depth- Including Door Dimension	25 ⁵ / ₁₆ " (643 mm)
Door Clearance	18 ¹ / ₄ " (463 mm)
Built-In	
Minimum Cabinet Opening Width	23 ⁵ / ₈ " (600 mm)
Minimum Cabinet Opening Height	33 ¹ / ₂ " (850 mm)
Interior Volume	
Drum Volume	2.26 cft (64 l)
Rated Load Capacity	17.6 lbs (8 kg)
Plumbing	
Water Supply Requirements	May be connected to a cold and hot water supply up to a maximum of 140°F/60°C. Must be connected to a shut-off valve with a male 3/4" GHT. The water shut-off valve must be accessible after installation. The water pressure must be between 14.5 psi (1 bar) and may not exceed 145 psi (10 bar). If the pressure is higher than 145 psi (10 bar), a pressure reducing valve must be installed.
Water Connection Line	5' 3" (1.6 m) flexible water intake hose is supplied with a 3/4" GHT connection.
Drain Hose	5' (1.5 m) flexible drain hose is supplied. May be extended up to 16'5" (5 m). Delivery head must not exceed 3' 3" (1 m)
Electrical	
Electrical Requirements	120V, 60Hz, 15A 220V, 30A, 60Hz (Used with NEMA Adapter)
Power Cord	NEMA 5-15 plug, 5'3" ft (1.6 m)
Shipping	
Shipping Weight	231 lbs (105 kg)
Shipping Dimensions	26" W x 37" H x 27 ³ / ₁₆ " D
Support	
Call Miele	(800) 999-1360
Miele Website	www.mieleusa.com
20/20 Link	2020technologies.com



WWH 860 WCS
Item# 11WH8605USA



WWH 660 WCS
Item# 11WH6605USA



WWF 060 WCS
Item# 11WF0605USA



WWB 020 WCS
Item# 11WB0201USA

Installation Accessories:



WTV 502
Stacking kit

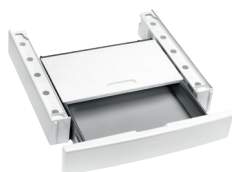

WTV 512
Stacking kit with drawer



WTS 510
Stacking kit with drawer



NEMA Adapter
NEMA 14-30/2x5-15 Adapter

W1 Washing Machine

PRODUCT VIEWS

Isometric View

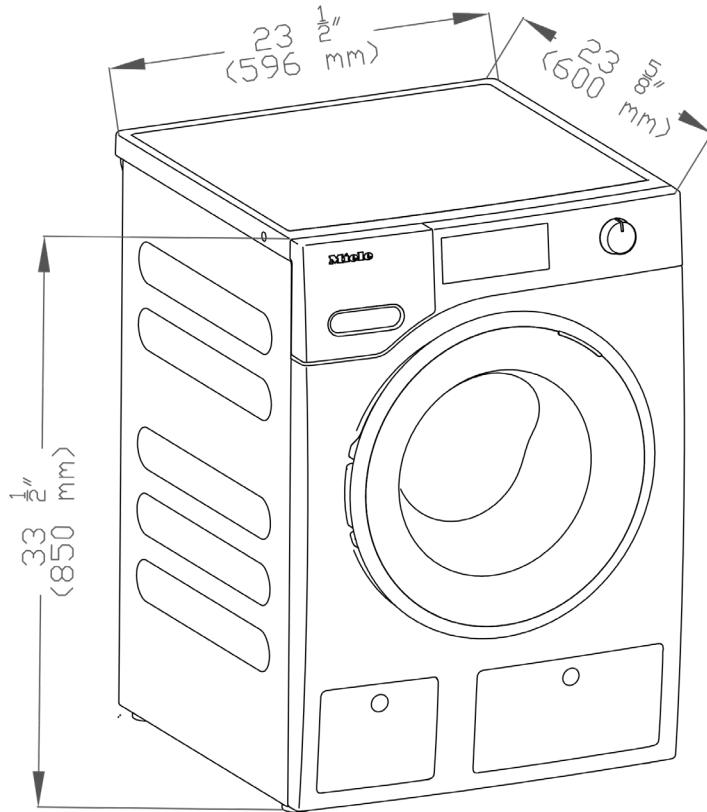

Front View

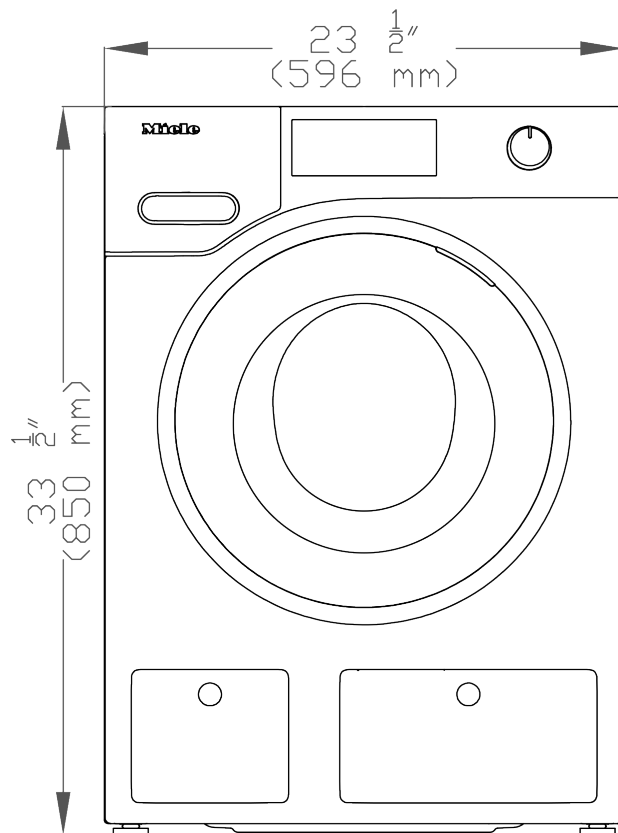

W1 Washing Machine

PRODUCT VIEWS

Side View

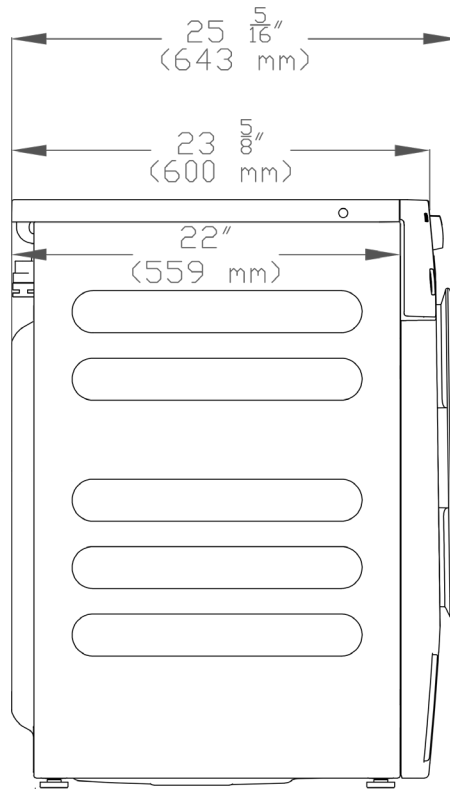

Side View With Door Open

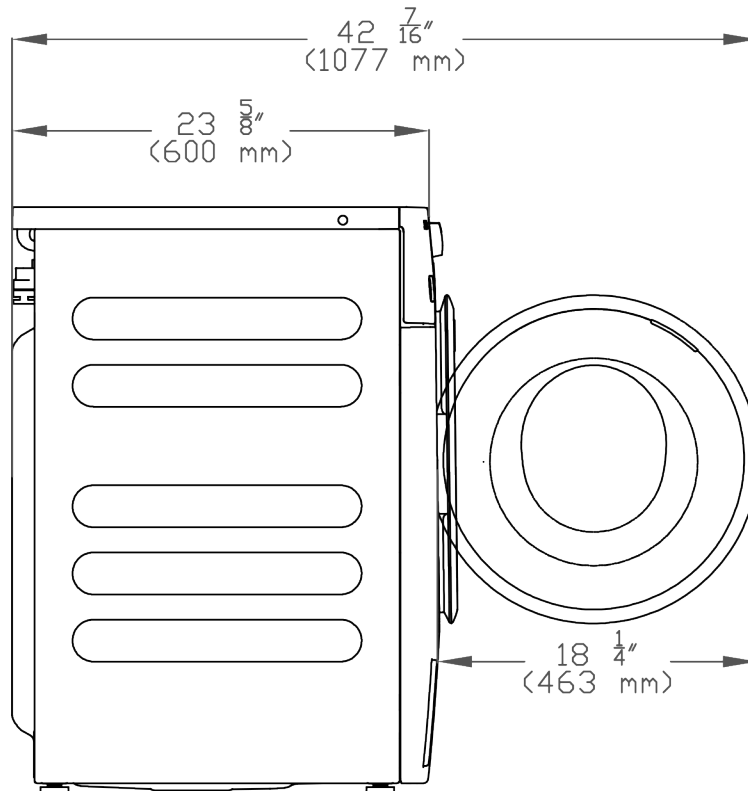

W1 Washing Machine

PRODUCT VIEWS

Door Swing

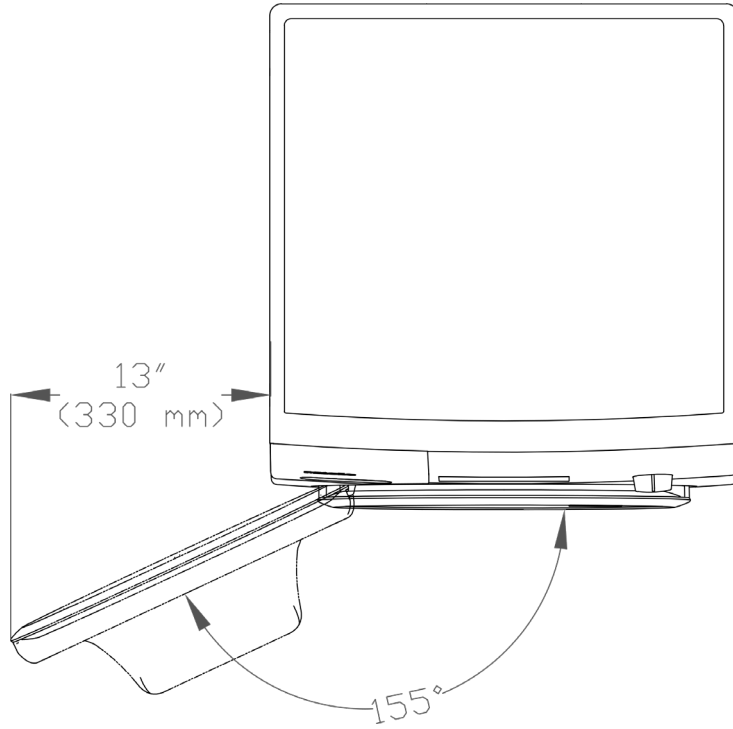

Rear View

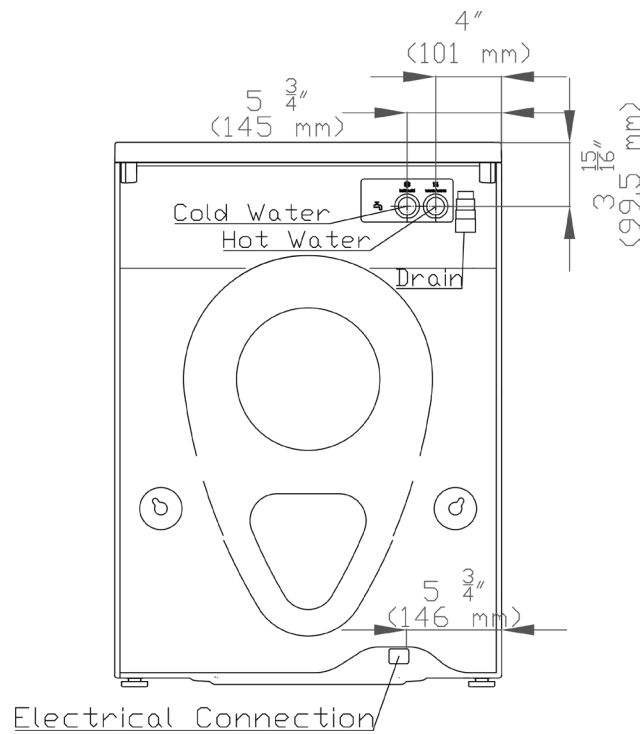

W1 Washing Machine

Built-in Niche

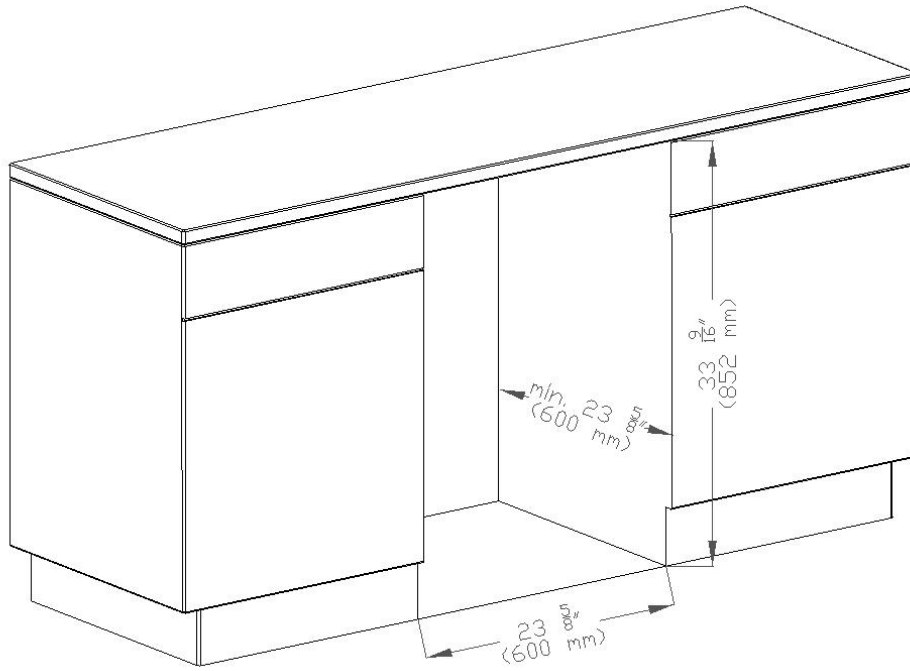

W1 Washing Machine

Stacked in Closet

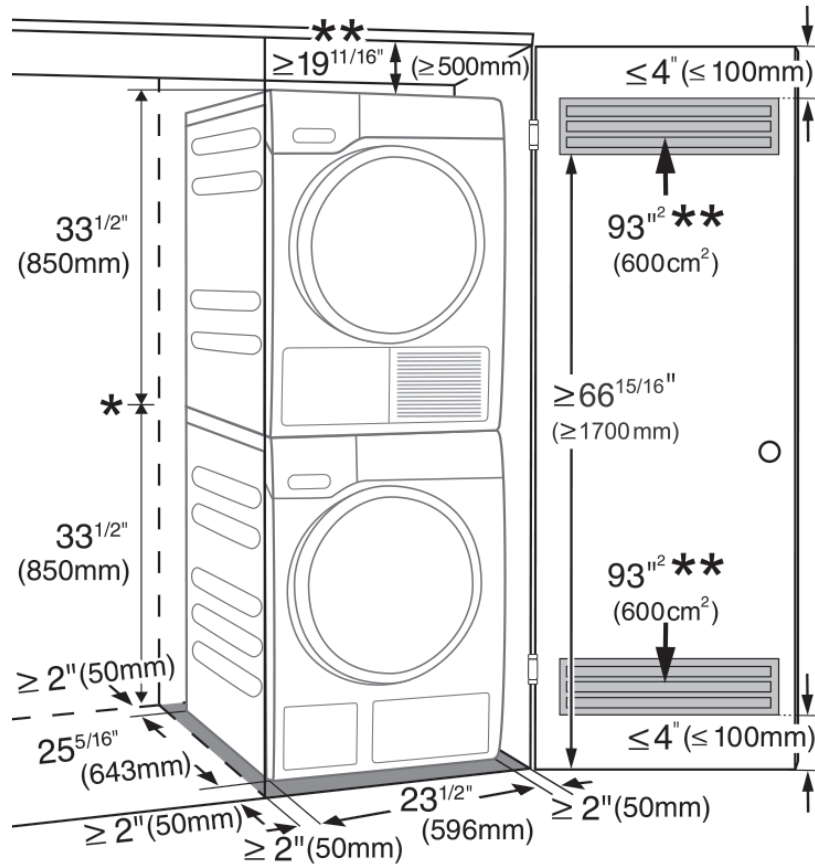

- * Height with Stacking Kit
WTV502 = $67\frac{3}{8}''$ (1711 mm)
WTV512 = $71\frac{1}{8}''$ (1806 mm)
- ** If it is not possible to fulfill the dimension specification you may have longer drying and process time.

W1 Washing Machine

Stacking Kit WTV 502 (Optional Accessory)

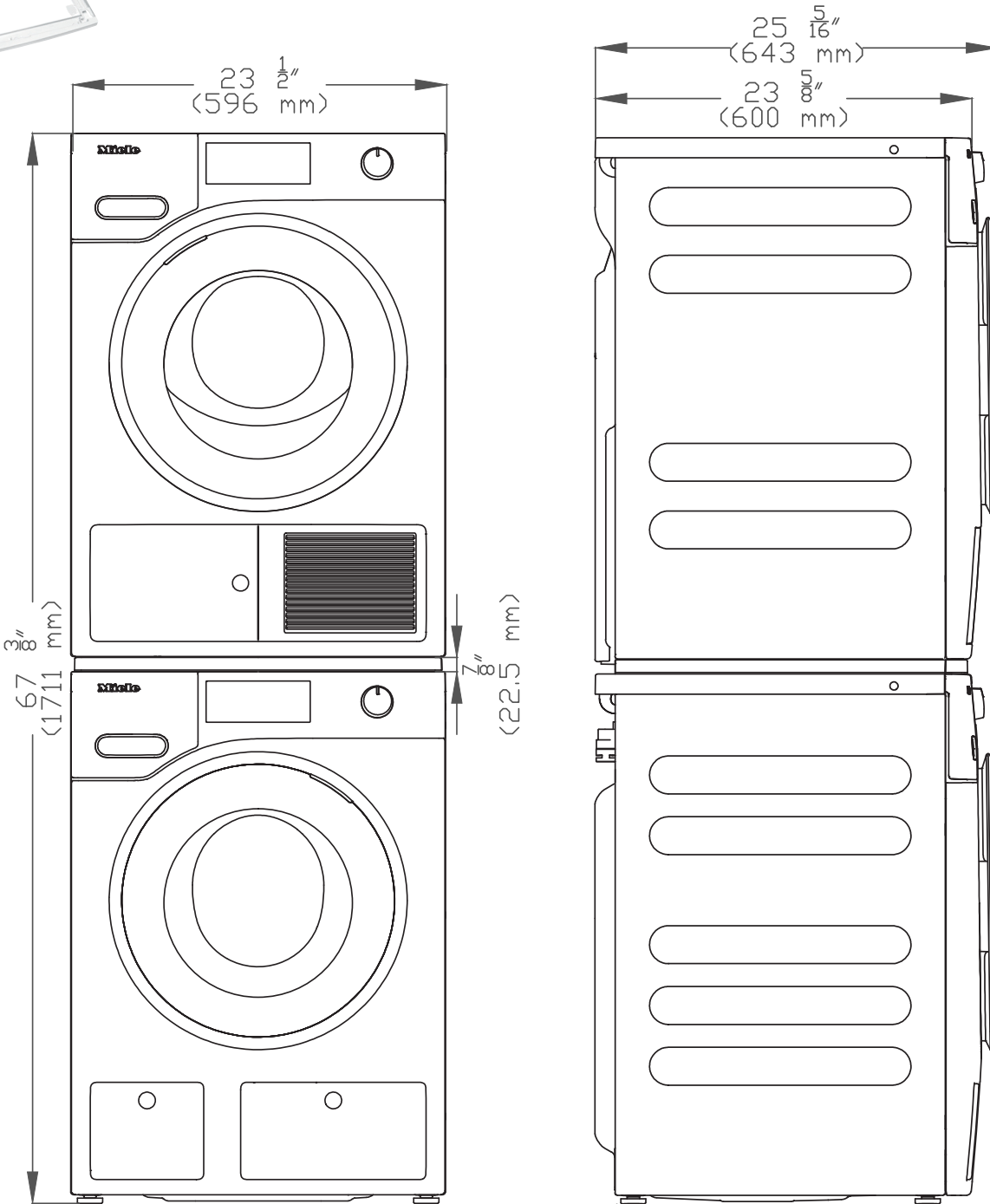

W1 Washing Machine

Stacking Kit With Drawer WTV 512 (Optional Accessory)

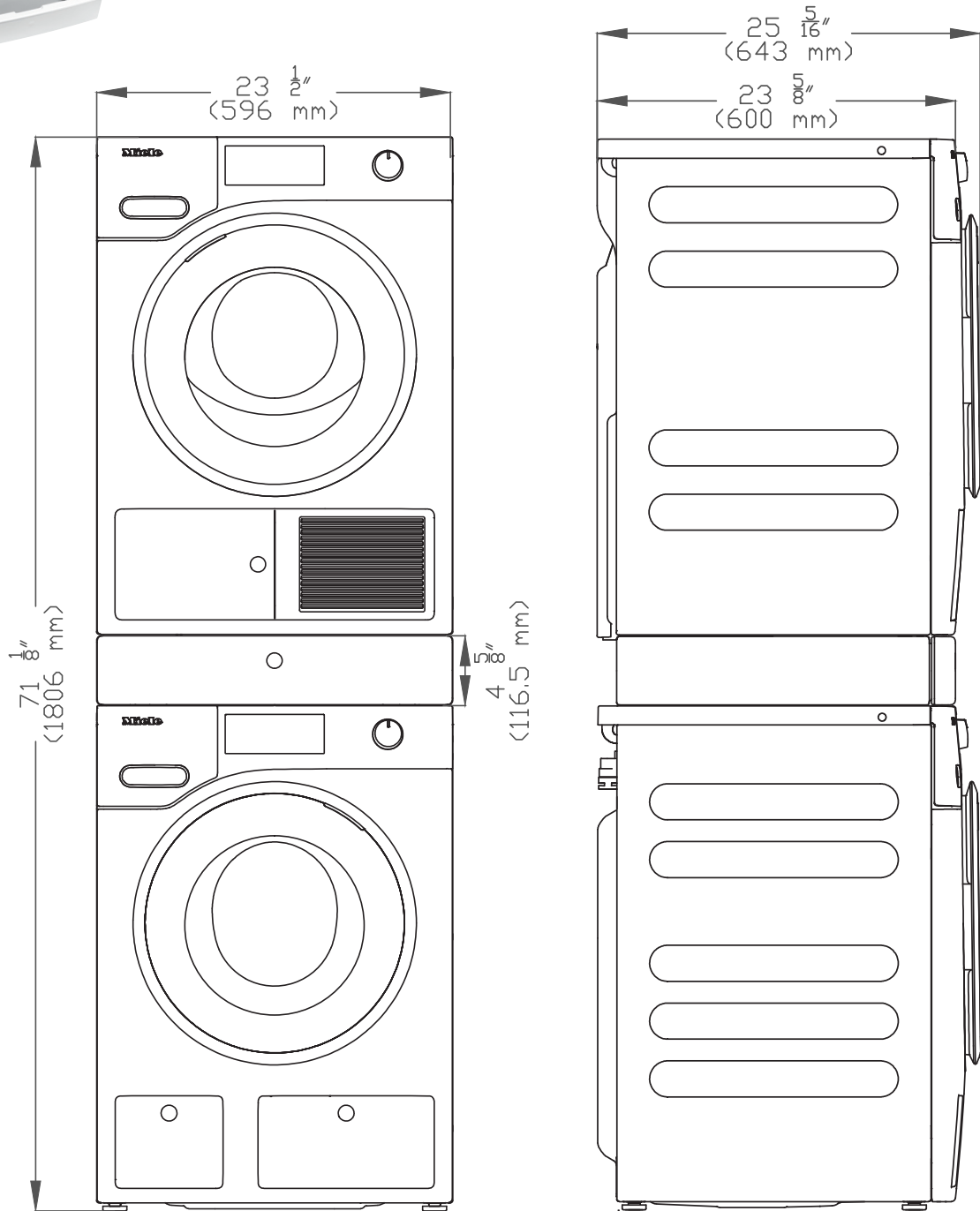
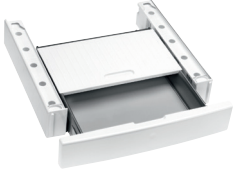

W1 Washing Machine

Plith WTS 510 (Optional Accessory)

