

Proper Disposal of Your Old Refrigerator

⚠️ WARNING

Suffocation Hazard

Remove doors from your old refrigerator.

Failure to do so can result in death or brain damage.

IMPORTANT: Child entrapment and suffocation are not problems of the past. Junked or abandoned refrigerators are still dangerous – even if they will sit for “just a few days.” If you are getting rid of your old refrigerator, please follow these instructions to help prevent accidents.

Before You Throw Away Your Old Refrigerator or Freezer:

- Take off the doors.
- Leave the shelves in place so that children may not easily climb inside.

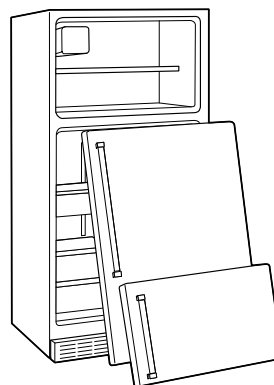

Important information to know about disposal of refrigerants:

Dispose of refrigerator in accordance with Federal and Local regulations. Refrigerants must be evacuated by a licensed, EPA certified refrigerant technician in accordance with established procedures.

INSTALLATION INSTRUCTIONS

Unpack the Refrigerator

⚠️ WARNING

Excessive Weight Hazard

Use two or more people to move and install refrigerator.

Failure to do so can result in back or other injury.

When Moving Your Refrigerator:

Your refrigerator is heavy. When moving the refrigerator for cleaning or service, be sure to cover the floor with cardboard or hardboard to avoid floor damage. Always pull the refrigerator straight out when moving it. Do not wiggle or “walk” the refrigerator when trying to move it, as floor damage could occur.

Remove the Packaging

IMPORTANT: Do not remove the white foam air return insert from behind the control panel on the ceiling of the refrigerator. If the insert is removed, ice may migrate down from the freezer and cause icicles to form.

- Remove tape and glue residue from surfaces before turning on the refrigerator. Rub a small amount of liquid dish soap over the adhesive with your fingers. Rinse with warm water and dry with a soft cloth.
- Do not use sharp instruments, rubbing alcohol, flammable fluids, or abrasive cleaners to remove tape or glue. These products can damage the surface of your refrigerator. For more information see “Refrigerator Safety.”

Clean Before Using

After you remove all of the package materials, clean the inside of your refrigerator before using it. See the cleaning instructions in “Refrigerator Care.”

Important information to know about glass shelves and covers:

Do not clean glass shelves or covers with warm water when they are cold. Shelves and covers may break if exposed to sudden temperature changes or impact, such as bumping. Tempered glass is designed to shatter into many small, pebble-size pieces. This is normal. Glass shelves and covers are heavy. Use both hands when removing them to avoid dropping.

Location Requirements

⚠ WARNING



Explosion Hazard

Keep flammable materials and vapors, such as gasoline, away from refrigerator.

Failure to do so can result in death, explosion, or fire.

IMPORTANT: This refrigerator is designed for indoor household use only.

To ensure proper ventilation for your refrigerator, allow for ½" (1.25 cm) of space on each side and at the top. Allow for 1" (2.54 cm) of space behind the refrigerator. If your refrigerator has an ice maker, allow extra space at the back for the water line connections. When installing your refrigerator next to a fixed wall, leave a 2" (5.08 cm) minimum space on the hinge side (some models require more) to allow the door to swing open.

NOTE: This refrigerator is intended for use in a location where the temperature ranges from a minimum of 55°F (13°C) to a maximum of 110°F (43°C). The preferred room temperature range for optimum performance, which reduces electricity usage and provides superior cooling, is between 60°F (15°C) and 90°F (32°C). It is recommended that you do not install the refrigerator near a heat source, such as an oven or radiator.

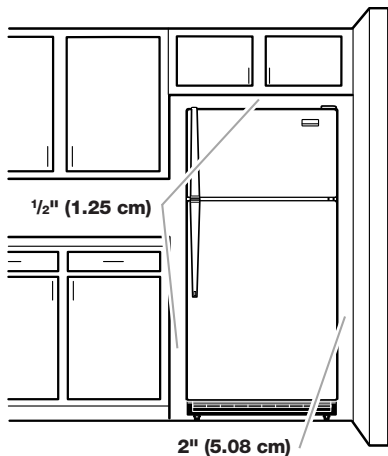

Electrical Requirements

⚠ WARNING



Electrical Shock Hazard

Plug into a grounded 3 prong outlet.

Do not remove ground prong.

Do not use an adapter.

Do not use an extension cord.

Failure to follow these instructions can result in death, fire, or electrical shock.

Before you move your refrigerator into its final location, it is important to make sure you have the proper electrical connection.

Recommended Grounding Method

A 115 volt, 60 Hz, AC only, 15- or 20-amp fused, grounded electrical supply is required. It is recommended that a separate circuit serving only your refrigerator be provided. Use an outlet that cannot be turned off by a switch. Do not use an extension cord.

NOTE: Before performing any type of installation or cleaning, or removing a light bulb, turn cooling off or turn the control (Thermostat, Refrigerator or Freezer Control depending on the model) to OFF, and then disconnect the refrigerator from the electrical source. When you are finished, reconnect the refrigerator to the electrical source and turn cooling on or reset the control (Thermostat, Refrigerator or Freezer Control depending on the model) to the desired setting. See "Using the Controls" in the User Instructions, User Guide, or Use & Care Guide.

Water Supply Requirements

Gather the required tools and parts before starting installation. Read and follow the instructions provided with any tools listed here.

Tools Needed:

- Flat-blade screwdriver
- ¼" Nut driver
- 7/16" and ½" Open-end or two adjustable wrenches
- ¼" Drill bit
- Cordless drill

NOTE: Your refrigerator dealer has a kit available with a ¼" (6.35 mm) saddle-type shutoff valve, a union, and copper tubing. Before purchasing, make sure a saddle-type valve complies with your local plumbing codes. Do not use a piercing-type or 3/16" (4.76 mm) saddle valve which reduces water flow and clogs more easily.

IMPORTANT:

- All installations must meet local plumbing code requirements.
- Use copper tubing and check for leaks. Install copper tubing only in areas where the household temperatures will remain above freezing.

Water Pressure

A cold water supply with water pressure of between 30 and 120 psi (207 and 827 kPa) is required to operate the water dispenser and ice maker. If you have questions about your water pressure, call a licensed, qualified plumber.

Reverse Osmosis Water Supply

IMPORTANT: The pressure of the water supply coming out of a reverse osmosis system going to the water inlet valve of the refrigerator needs to be between 30 and 120 psi (207 and 827 kPa).

If a reverse osmosis water filtration system is connected to your cold water supply, the water pressure to the reverse osmosis system needs to be a minimum of 40 to 60 psi (276 to 414 kPa).

If the water pressure to the reverse osmosis system is less than 40 to 60 psi (276 to 414 kPa):

- Check to see whether the sediment filter in the reverse osmosis system is blocked. Replace the filter if necessary.
- Allow the storage tank on the reverse osmosis system to refill after heavy usage.

If you have questions about your water pressure, call a licensed, qualified plumber.

Connect the Water Supply

Read all directions before you begin.

IMPORTANT: If you turn ON the refrigerator before the water line is connected, turn OFF the ice maker.

Connect to Water Line

1. Unplug refrigerator or disconnect power.
2. Turn OFF main water supply. Turn ON nearest faucet long enough to clear line of water.
3. Locate a ½" to 1¼" (1.25 cm to 3.18 cm) vertical cold water pipe near the refrigerator.
IMPORTANT:
 - Make sure it is a cold water pipe.
 - Horizontal pipe will work, but drill on the top side of the pipe, not the bottom. This will help keep water away from the drill and normal sediment from collecting in the valve.
4. Determine the length of copper tubing you need. Measure from the connection on the lower left rear of refrigerator to the water pipe. Add 7 ft (2.1 m) to allow for cleaning. Use ¼" (6.35 mm) O.D. (outside diameter) copper tubing. Be sure both ends of copper tubing are cut square.
5. Using a cordless drill, drill a ¼" hole in the cold water pipe you have selected.

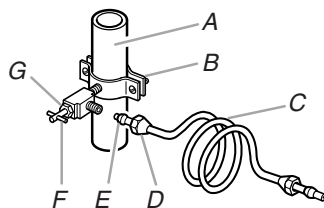

A. Cold water pipe
B. Pipe clamp
C. Copper tubing
D. Compression nut
E. Compression sleeve
F. Shutoff valve
G. Packing nut

6. Fasten the shutoff valve to the cold water pipe with the pipe clamp. Be sure the outlet end is solidly in the ¼" drilled hole in the water pipe and that the washer is under the pipe clamp. Tighten the packing nut. Tighten the pipe clamp screws slowly and evenly so washer makes a watertight seal. Do not overtighten or you may crush the copper tubing.

7. Slip the compression sleeve and compression nut on the copper tubing as shown. Insert the end of the tubing into the outlet end squarely as far as it will go. Screw compression nut onto outlet end with adjustable wrench. Do not overtighten.
8. Place the free end of the tubing in a container or sink, and turn ON the main water supply. Flush the tubing until water is clear. Turn OFF the shutoff valve on the water pipe. Coil the copper tubing.

Connect to Refrigerator

1. Unplug refrigerator or disconnect power.
2. Attach the copper tubing to the valve inlet using a compression nut and sleeve as shown. Tighten the compression nut. Do not overtighten.
3. Use the tube clamp on the back of the refrigerator to secure the tubing to the refrigerator as shown. This will help avoid damage to the tubing when the refrigerator is pushed back against the wall.
4. Turn shutoff valve ON.
5. Check for leaks. Tighten any connections (including connections at the valve) or nuts that leak.

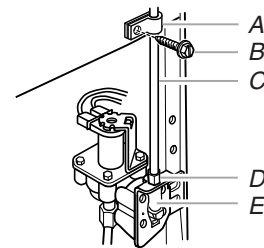

A. Tube clamp
B. Tube clamp screw
C. Copper tubing
D. Compression nut
E. Valve inlet

6. The ice maker is equipped with a built-in water strainer. If your water conditions require a second water strainer, install it in the ¼" (6.35 mm) water line at either tube connection. Obtain a water strainer from your nearest appliance dealer.

Complete the Installation

⚠ WARNING



Electrical Shock Hazard

Plug into a grounded 3 prong outlet.

Do not remove ground prong.

Do not use an adapter.

Do not use an extension cord.

Failure to follow these instructions can result in death, fire, or electrical shock.

1. Plug into a grounded 3 prong outlet.

NOTE: Allow 24 hours to produce the first batch of ice. Discard the first three batches of ice produced. Allow 3 days to completely fill ice container.

Refrigerator Doors

Depending on the width of your doorway, you may need to remove the doors to move the refrigerator into your home. Also, the door hinges are factory installed on the right-hand side. If you want the door to open from the other direction, you must reverse the door swing.

IMPORTANT:

- Before you begin, turn OFF the refrigerator control, unplug the refrigerator or disconnect power. Remove food and any adjustable door or utility bins from doors.
- Depending on your model, your refrigerator has either **Style 1—Contour Doors** or **Style 2—Standard Doors**. Reference the graphic specific to your model later in this section following "Final Steps."

NOTE: A Reversibility Kit, which includes a new Brand Badge and hole covers, is available.

Tools Needed: $\frac{5}{16}$ " Hex-head socket wrench, #2 Phillips screwdriver, Flat-blade screwdriver, $\frac{5}{16}$ " Open-end wrench, Flat 2" putty knife.

Remove Doors and Hinges

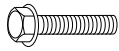

$\frac{5}{16}$ " Hex-Head Hinge Screw

1. Unplug refrigerator or disconnect power.
2. Using a hex-head socket wrench, remove the three $\frac{5}{16}$ " hex-head hinge screws from the top hinge and lift up to remove the hinge. See top hinge graphic.

NOTE: Provide additional support for the doors while the hinges are being moved. Do not depend on the door magnets to hold the doors in place while you are working.

3. Lift the freezer door off of the center hinge and set it aside.
4. Remove the washer from the top of the center hinge pin.

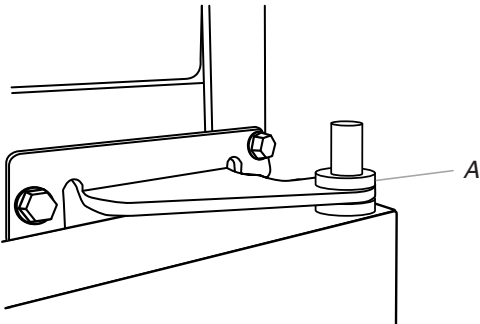

A. Washer

5. Using a hex-head socket wrench and an open-end wrench, remove the three screws from the center hinge and remove the hinge. Set aside.

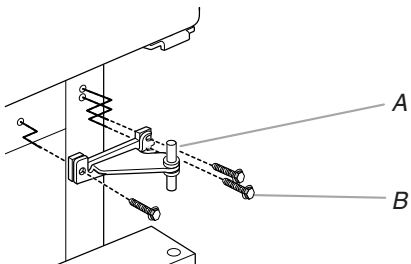

A. Center hinge
B. $\frac{5}{16}$ " Hex-head hinge screws

6. Remove the washer from the bottom of the center hinge pin.
7. Lift the refrigerator door from the bottom hinge, and set aside.
8. Using a hex-head socket wrench, remove the four $\frac{5}{16}$ " hex-head hinge screws from the bottom hinge and pull the hinge from the bottom of the refrigerator door.

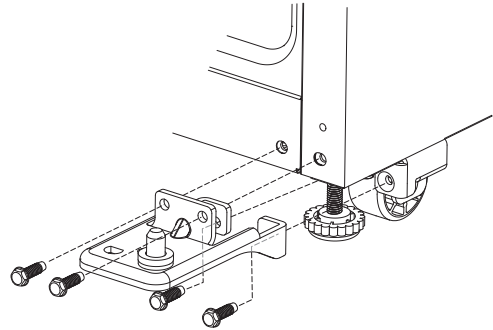

Reverse Doors and Hinges (optional)

IMPORTANT: If you want to reverse your doors so that they open in the opposite direction, follow these steps. If you are not reversing the doors, see "Replace Doors and Hinges."

See complete graphics later in these instructions.

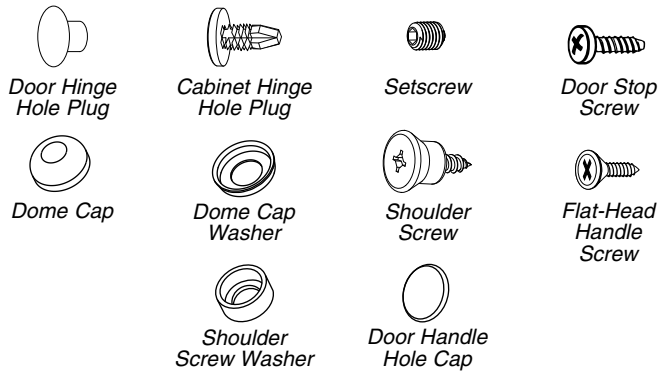

Reverse Center Hinge

1. Remove the three dome caps and screws from the handle side and use them to fill the holes created when the hinge screws were removed.

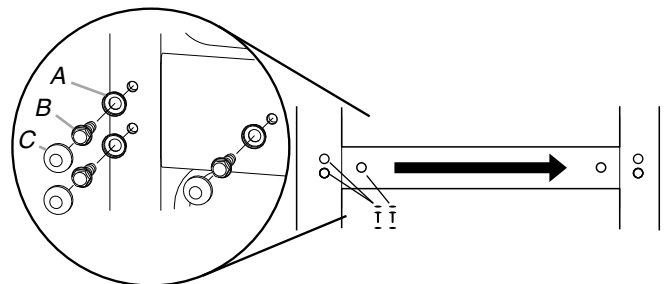

A. Dome cap washers
B. Hex-head hinge screws

C. Dome caps

2. Using the three $\frac{5}{16}$ " hex-head hinge screws, removed in Step 1, insert two screws halfway into the holes, leaving space to insert the center hinge.
3. Once the refrigerator door is in place, slide the center hinge from the right onto the screws, insert the third screw, and then tighten all screws completely.

NOTE: Make sure the washers are in place on both the top and bottom pins of the center hinge.

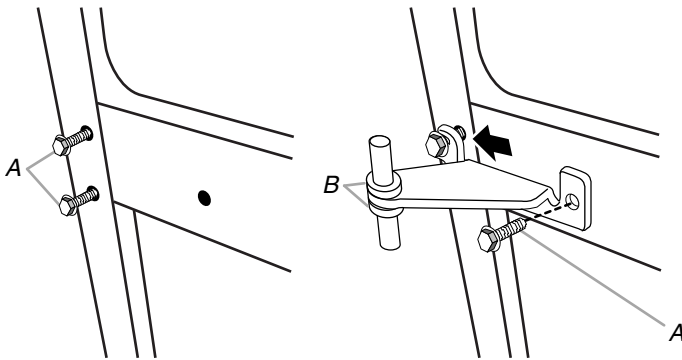

A. $\frac{5}{16}$ " Hex-head hinge screws
B. Washers

Reverse Freezer Door

1. Remove the three cabinet hole plugs from the top of the cabinet and place them in the hinge holes on the opposite side.



A. Cabinet hole plugs

2. Remove the door handles. See the model specific graphics later in these instructions.

Door Handles Installed with Flat-head Screws and Setscrews

- Remove the two flat-head handle screws from the bottom of the freezer door handle.
- Using the $\frac{1}{8}$ " hex key, loosen the setscrew attaching the top of the handle.
- Pull the handle away from the door to release it from the shoulder screw. Keep all parts together.

Door Handles Installed with Flat-head Screws Only

- Remove the screw cover and the three flat-head handle screws. Keep all parts together.
3. Using the plastic tool (provided), remove the brand badge from the freezer door by prying up the right-hand side and slowly peeling the badge away from the door, revealing the hole to mount the door handle.

NOTES:

- To avoid scratching the finish, do not use a sharp or metallic object to pry the brand badge from the door.
- Rub a small amount of liquid dish soap over any adhesive residue with your fingers. Rinse the door with warm water and dry with a soft cloth.

4. Depending on your model, remove the shoulder screw and its washer from the left-hand side of the door and fasten it into the hole that was behind the brand badge.
5. Remove the door stop from the bottom of the freezer door.

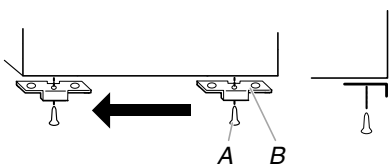

A. Door stop screw
B. Door stop

6. Move the door stop to the opposite side making sure that the hole in the door stop plate is aligned perfectly with the hole for the center hinge pin.
7. Using the screw removed earlier, fasten the door stop to the bottom of the freezer door.

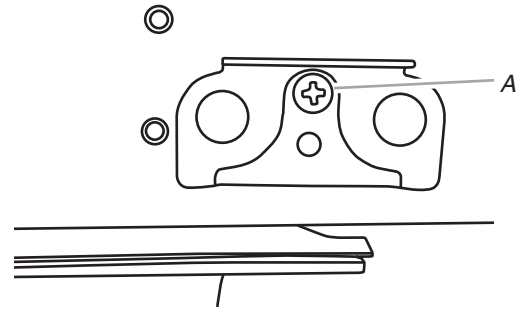

A. Door stop screw

8. Depending on your model, place the handle on the shoulder screw and push the handle toward the door until the mounting base is flush against the door.

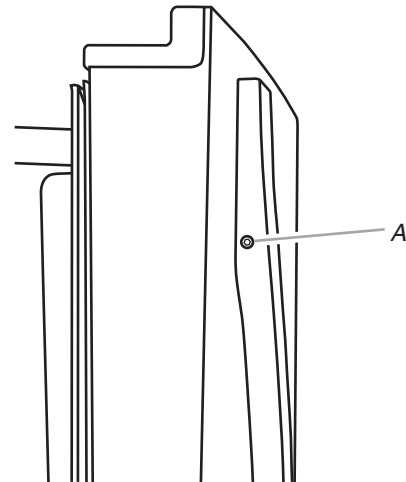

A. Setscrew

9. Fasten the bottom of the handle to the bottom of the freezer door.
10. Tighten all screws. Set aside the freezer door until the hinges and refrigerator door are in place.

Reverse Refrigerator Door

1. Remove the door stop from the bottom of the refrigerator door.

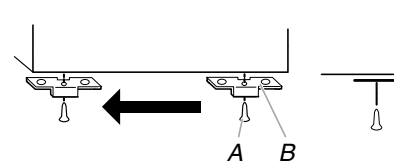

A. Door stop screw
B. Door stop

2. Replace the door stop on the opposite side of the refrigerator door, making sure that the hole in the door stop plate is perfectly with the hole for the bottom hinge pin.
3. Fasten the door stop to the door.
4. Remove the door handles. See the model specific graphics later in these instructions.

Door Handles Installed with Flat-head Screws and Setscrews

- Remove the screws from the top of the refrigerator door handle.
- Remove the setscrew from the lower part of the handle.
- Pull the handle away from the door to release it from the shoulder screw. Keep all parts together.

Door Handles Installed with Flat-head Screws Only

- Remove the screw cover, and the three flat-head handle screws. Keep all parts together.
5. Remove the cap covering the hole on the opposite side of the door, where the refrigerator door handle will be installed, and discard the cap.

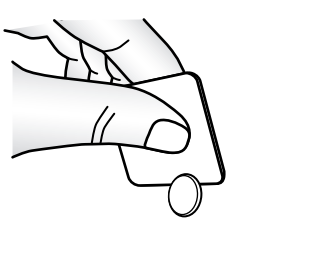

6. Depending on your model, remove the shoulder screw and its washer from the left-hand side of the door and fasten it into the hole that was behind the cap.
7. Depending on your model, place the handle on the shoulder screw and push the handle toward the door until the mounting base is flush against the door.
8. Fasten the top of the refrigerator handle to the top of the refrigerator door.

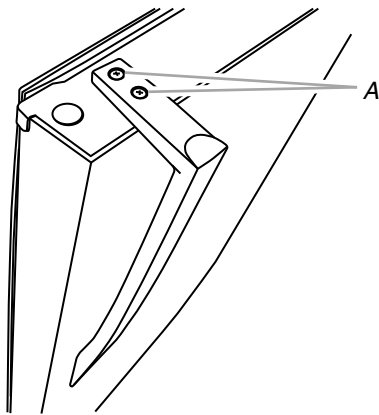

A. Flat-head handle screws

9. Cover the remaining hole with the cap (provided).

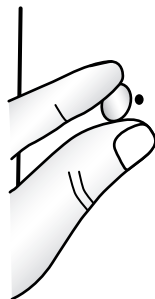

10. Remove door hinge hole plug from the refrigerator door. Move to opposite side.
11. Tighten all screws. Set aside refrigerator door until bottom hinge is installed on the opposite side of the refrigerator.

Reverse Top Hinge - Contour Door models only

1. Remove the screw attaching the hinge pin to the hinge. Turn the hinge over so that it is pointing in the opposite direction.
2. Place the plastic spacer beneath the hinge so that it will be between the hinge and the cabinet, making sure the holes are aligned.

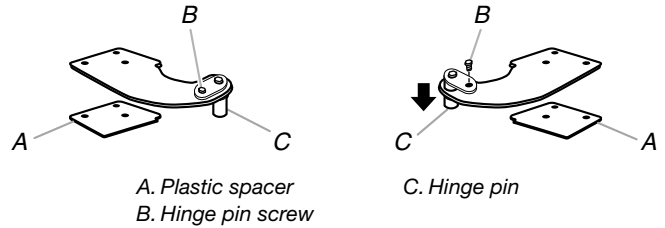

A. Plastic spacer
B. Hinge pin screw

3. Fasten the top hinge to the opposite side of the cabinet, inserting the screws only halfway, so you will be able to replace and align the freezer door later.

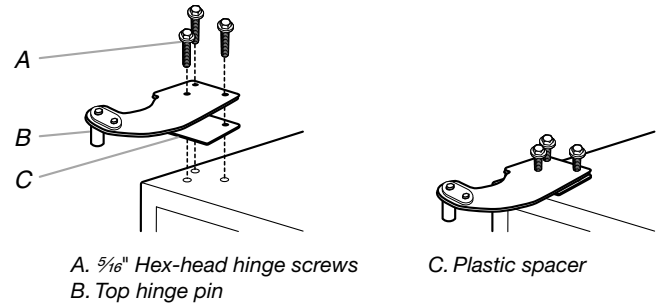

A. 5/16" Hex-head hinge screws
B. Top hinge pin

C. Plastic spacer

Replace Doors and Hinges

IMPORTANT: Provide additional support for the doors while the hinges are being moved. Do not depend on the door magnets to hold the doors in place while you are working.

Install Refrigerator Door

1. Insert the hinge pin into the bottom hinge of the refrigerator door and fasten the hinge to the cabinet. Do not tighten completely.

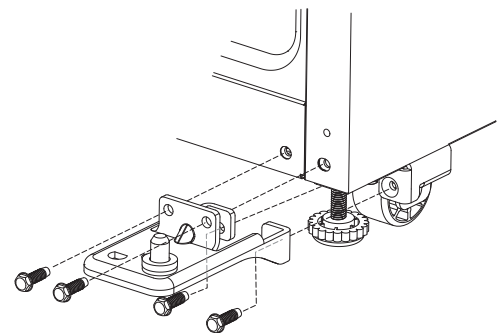

A. Bottom hinge

2. Place the washer on top of the bottom hinge pin.
3. Place the refrigerator door onto the bottom hinge pin.
4. Measure the distance from the bottom of the refrigerator door to the floor. The distance should be approximately 1 1/8" (4.6 cm).

NOTE: If necessary, loosen the bottom hinge, without removing the screws, adjust the door to the correct height and fully tighten the screws.

Install Freezer Door

1. Place washer on the upper hinge pin of the center hinge.
2. Place the freezer door on the upper hinge pin of the center hinge.
3. Insert the top hinge pin into the drilled hole in the top of the freezer door. Do not tighten the screws completely.
4. Align the doors so that the bottom of the freezer door aligns evenly with the top of the refrigerator door. Tighten all screws.

NOTE: The distance between the doors should be approximately $\frac{3}{4}$ " (19 mm).

Style 1—Contour Door

Final Steps

1. Plug in the refrigerator or reconnect the power.
2. Reset the controls. See "Using the Controls."
3. Return all removable door parts to doors and food to refrigerator.

Door Removal & Replacement

Top Hinge

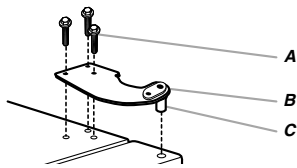

- A. $\frac{5}{16}$ " Hex-Head Hinge Screws
- B. Top Hinge
- C. Hinge Pin

Center Hinge

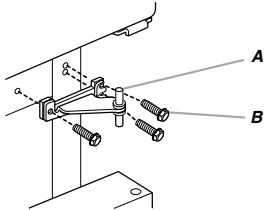

- A. Center Hinge
- B. $\frac{5}{16}$ " Hex-Head Hinge Screws

Bottom Hinge

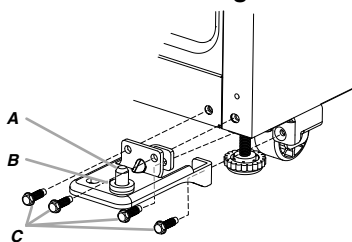

- A. Bottom Hinge
- B. Washer
- C. $\frac{5}{16}$ " Hex-Head Hinge Screws

Door Swing Reversal (optional)

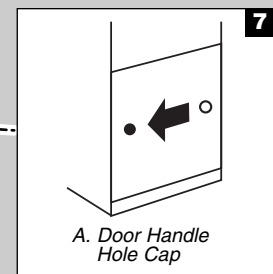
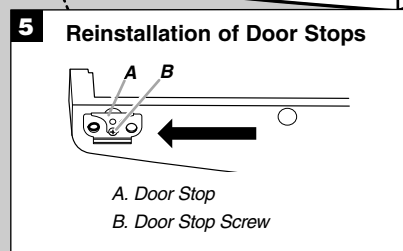
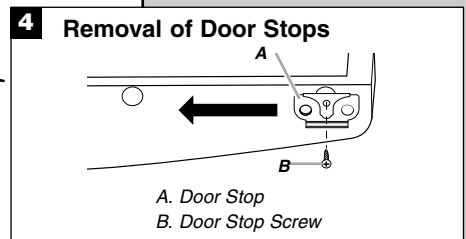
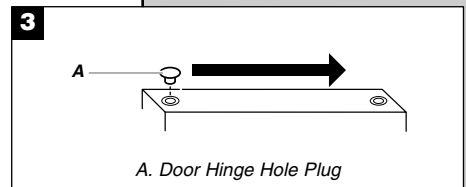
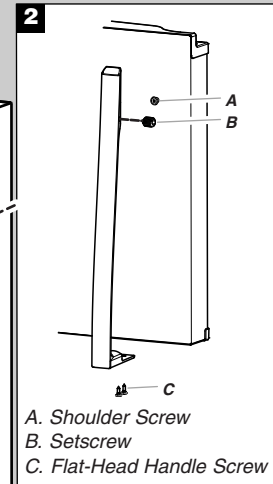
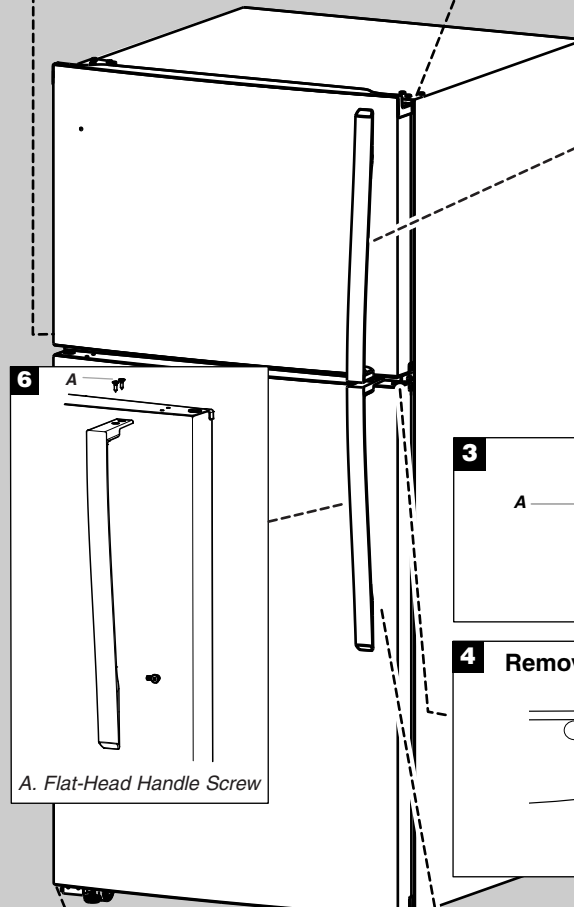
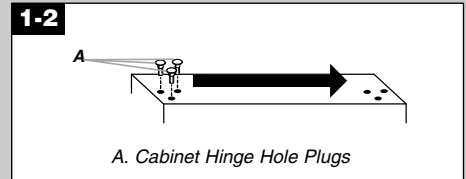
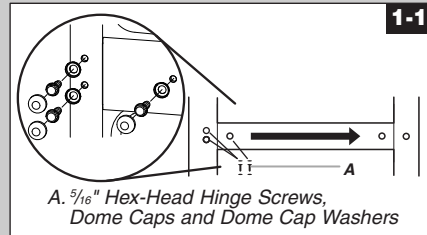

Door Removal & Replacement

Top Hinge

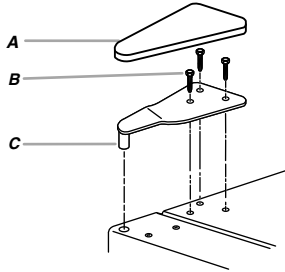

- A. Top Hinge Cover
- B. 5/16" Hex-Head Hinge Screws
- C. Top Hinge

Center Hinge

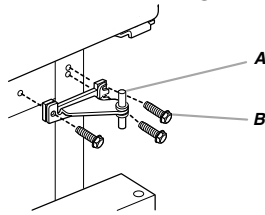

- A. Center Hinge
- B. 5/16" Hex-Head Hinge Screws

Bottom Hinge

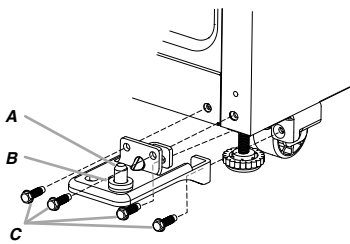

- A. Bottom Hinge
- B. Washer
- C. 5/16" Hex-Head Hinge Screws

Door Swing Reversal (optional)



A. Cabinet Hinge Hole Plugs

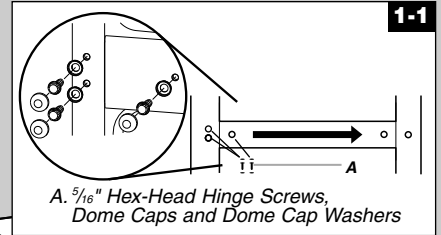

A. 5/16" Hex-Head Hinge Screws, Dome Caps and Dome Cap Washers

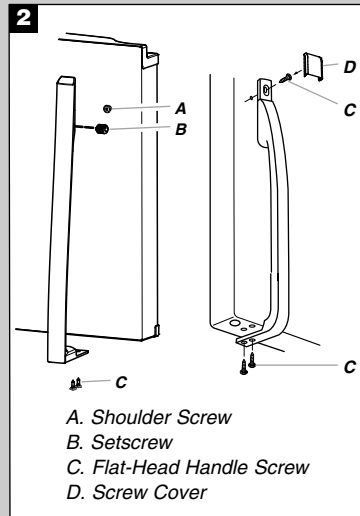

- A. Shoulder Screw
- B. Setscrew
- C. Flat-Head Handle Screw
- D. Screw Cover

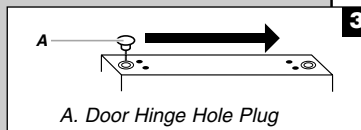

A. Door Hinge Hole Plug

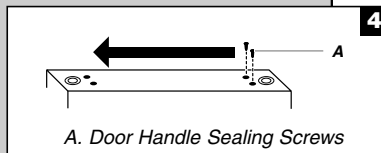

A. Door Handle Sealing Screws

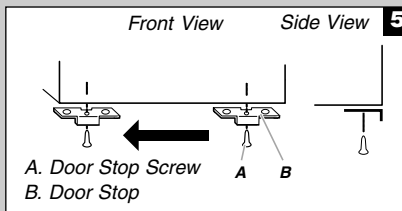

- A. Door Stop Screw
- B. Door Stop

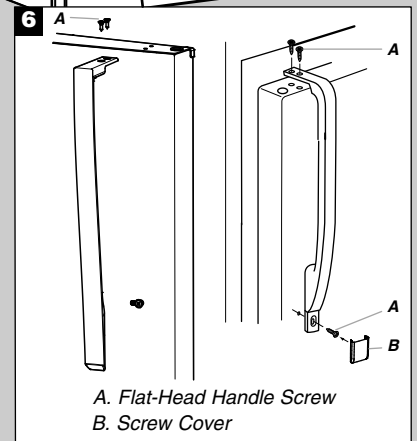

- A. Flat-Head Handle Screw
- B. Screw Cover

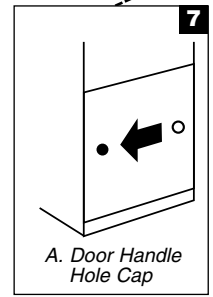

A. Door Handle Hole Cap

Reversibility Kit Instructions

If your model came with a Reversibility kit, please use the Brand Badge Placement template and the following instructions to install the Brand Badge on the opposite side of the freezer door.

Parts Included:

Brand badge removal tool
Brand badge template (on last page of User Instructions)
Door handle hole cap

Tools Needed:

Scissors
Masking tape

Freezer Door

1. Using the removal tool (provided), remove the brand badge from the freezer door by lifting up the right-hand side and peeling the badge away from the door from right to left.
NOTE: To avoid scratching the door, do not use a sharp or metallic object to pry the brand badge from the door.
2. Rub a small amount of liquid dish soap over any adhesive residue with your fingers. Rinse the door with warm water and dry with a soft cloth.
3. Cut the template along the dotted lines that match the shape of the brand badge.
4. Align the edges of the template with the side and top of the freezer door and tape the template to the door.
NOTE: When the template is correctly aligned, the hole in the door, where the handle was, will be within the cutout of the template, as shown.

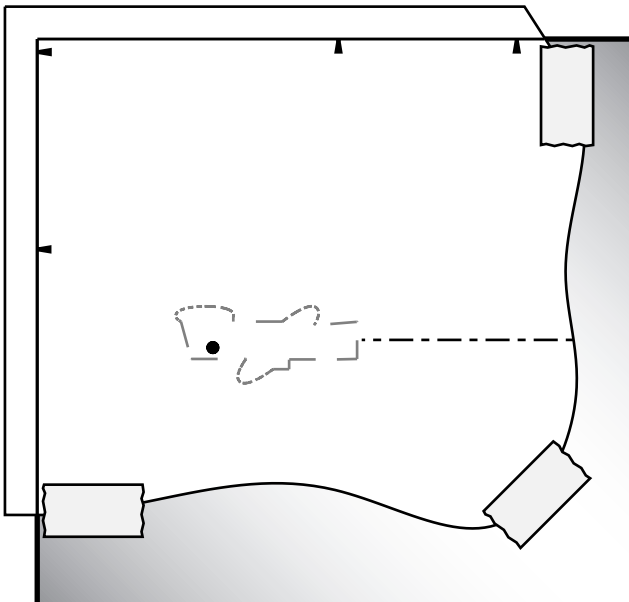

5. Using the cutout as a guide, press the brand badge onto the freezer door making sure that the hole is completely covered.
6. Slowly remove the template.

Adjust the Doors

IMPORTANT: Your refrigerator complies with American Disabilities Act (ADA) guidelines.

Door Closing

Your refrigerator has two front adjustable levelers - one on the right and one on the left. If your refrigerator seems unsteady or you want the doors to close easier, adjust the refrigerator's tilt using the following instructions:

1. Turn the leveler to lower or raise that side of the refrigerator. It may take several turns to adjust the tilt of the refrigerator.
 - To raise, turn the leveler to the right.
 - To lower, turn the leveler to the left.**NOTE:** Having someone push against the top of the refrigerator takes some weight off the levelers and rollers which makes it easier to adjust.

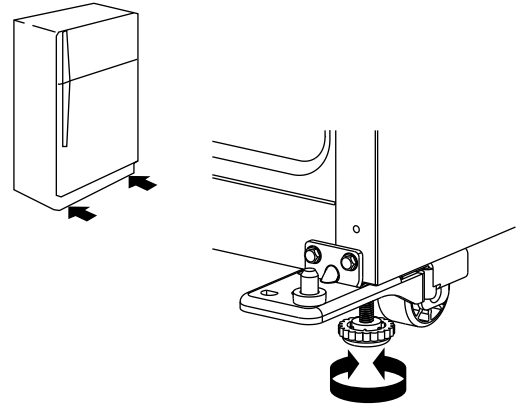

2. Open both doors again to make sure they close as easily as you like. If not, tilt the refrigerator slightly more to the rear by turning both leveling legs to the left; it may take several more turns.
NOTE: To keep the refrigerator level, you should turn both leveling legs the same amount.
3. Using a level, be sure that the refrigerator is still level side to side. Readjust if necessary.

Door Aligning

If the space between your doors looks uneven, you can adjust it using the following instructions:

1. Depending on your model, remove the top hinge cover.
2. Loosen the top hinge screws using a $\frac{5}{16}$ " socket or wrench.
3. Have someone hold the door in place or put a spacer between the doors while you tighten the top hinge screws.
4. Replace the top hinge cover, if removed in Step 1.

REFRIGERATOR USE

Using the Controls

Your refrigerator has two controls that affect the temperature. The Temperature control located at the top front of the refrigerator compartment and the Airflow control located on the back wall of the freezer compartment.

IMPORTANT:

- The recommended setting should be correct for normal household refrigerator use. The controls are set correctly when milk or juice is as cold as you like and when ice cream is firm.
 - Wait 24 hours for your refrigerator to cool completely before adding food. If you add food before the refrigerator has cooled completely, your food may spoil.
- NOTE:** Adjusting the refrigerator and freezer temperature controls to a colder than recommended setting will not cool the compartments any faster.
- If the temperature is too warm or too cold in the refrigerator or freezer, first check the air vents to be sure they are not blocked before adjusting the controls.