



TRAP SEALS

- Minimizes evaporation within the trap
- Prevents sewer gases from escaping into the room and helps to mitigate backflow
- Seal opens to allow the flow of drainage and closes when there is no flow
- Great solution for infrequently used floor drains
- Can be used in new construction or retrofit applications
- Quick and simple installation - no special tools needed
- Durable EPDM construction
- Meets ASSE 1072-2020
- UPC Listed



STD 1072
RATED: AF-GW

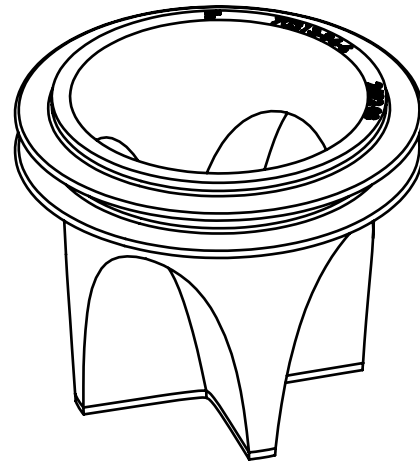
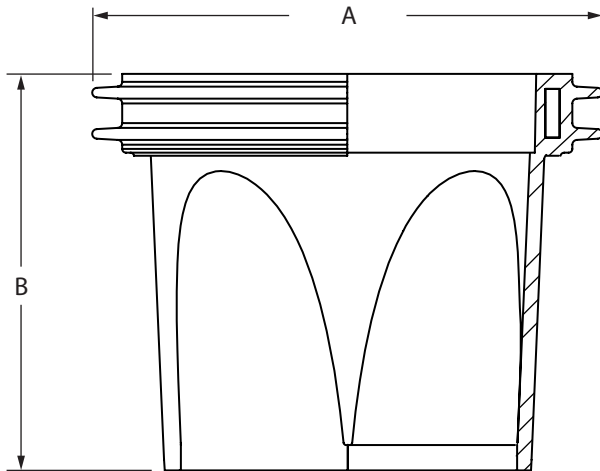

Part No.	Size	Flow Rate	Weight	A (Dia.)	B (Height)
P26001	2 INCH TRAP SEAL	12 GPM	1.30 oz	2.22"	2.66"
P26002	3 INCH TRAP SEAL	34 GPM	2.90 oz	3.22"	2.66"
P26003	3.5 INCH TRAP SEAL	51 GPM	3.40 oz	3.79"	2.66"
P26004	4 INCH TRAP SEAL	73 GPM	3.70 oz	4.22"	2.66"