

THAINE

70" ANTIQUE BLACK COPPER DOUBLE-SLIPPER PEDESTAL TUB - NICKEL INTERIOR

SKU: 952090-70



FEATURES

Tub has visible interior seams.

Straight plinth with rolled bottom.

Chemically applied patina, so color is ingrained in the copper.

Copper tubs are handmade and therefore unique.

Expect slight variations in finish and dimensions.

Requires wall or floor-mount tub filler.

To keep the tub in premium condition, it is recommended to not use anything abrasive for bathing or cleaning, including products like Epsom salts, bristle brushes, and harsh soaps.

Overflow includes Extended Pop-Up Drain with Swivel Head.

A Standard overflow, which remain open to allow water into the drain.

Tub Drain Placement: Offset

Exterior Treatment: Smooth

Interior Treatment: Polished

Tap Deck: No

Drain Included: Optional

CONTENTS

TUB PAGE 2

REVISED 06/30/2021

THAINE

70" ANTIQUE BLACK COPPER DOUBLE-SLIPPER PEDESTAL TUB - NICKEL INTERIOR

SKU: 952090-70

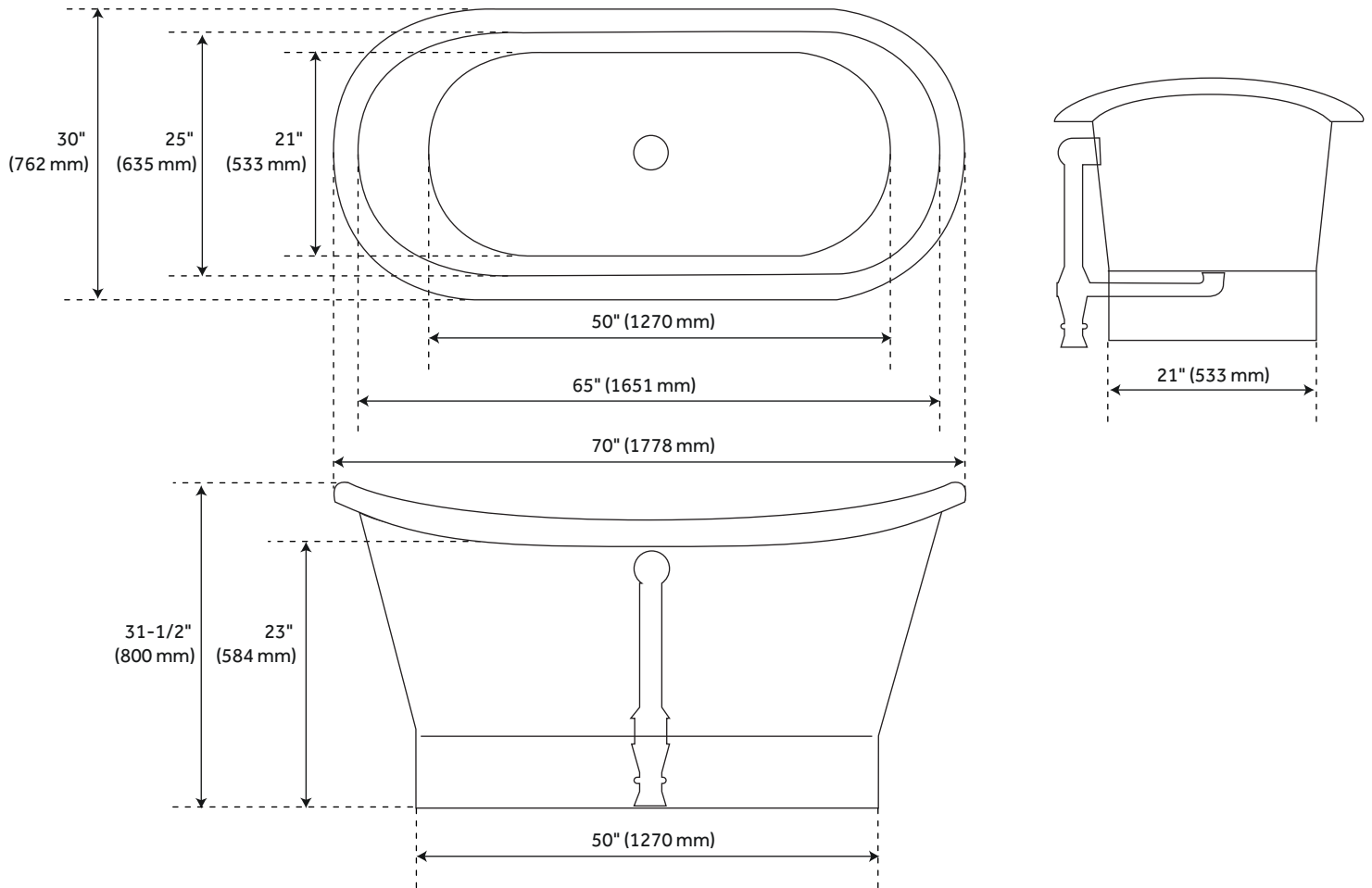

FEATURES

- Length: 70"
- Width: 30"
- Height: 31-1/2"
- Interior Length: 65"
- Interior Width: 25"
- Water Capacity with Overflow: 58 Gal.
- Tub Weight Crated: 237
- Tub Weight Uncratted: 96 Lbs.

PRODUCT IMAGE



All dimensions and specifications are nominal and may vary. Use actual products for accuracy in critical situations.

PAGE 2