



Ultra Low NOx Atmospheric Vent Water Heaters with Direct Spark Ignition



SERVICE MANUAL

Troubleshooting Guide
and Instructions for Service

(To be performed ONLY by
qualified service providers)

Models Covered by This Manual:

UCG(80,100)H399*(N,X)
(* Denotes Warranty Years)

Effective: November, 2015
ECO 7964



As required by the state of California Proposition 65.

Ultra Low NOx Atmospheric Vent Water Heaters with Direct Spark Ignition

Table of Contents

Introduction.....	3
How to Use This Manual	4
Tools Required for Service.....	4
Features	5
Specifications	6
Sequence of Operation	9
Troubleshooting.....	11
Service Procedure I: Thermostat Circuit Testing and Replacement.....	16
Service Procedure II: Combustion System Testing and Replacement.....	21
Service Procedure III: Burner Tube Inspection and Replacement	25
Service Procedure IV: Gas Valve Replacement.....	27
Service Procedure V: Blower Testing and Replacement	28
Service Procedure VI: Flame Sensor Testing and Replacement	30
Service Procedure VII: Spark Rod Gap Adjustment and Replacement.....	32
Service Procedure VIII: Ignition Module/Control Board Replacement.....	34
Service Procedure IX: Blocked Vent Switch Inspection and Replacement	35
Service Procedure X: Anode Inspection and Replacement	36
Service Procedure XI: Display Module Replacement.....	37
Service Procedure XII: Transformer Replacement.....	38
Water Heater Installation Check list	39
Water Heater Service Report	40
Parts List	41
Glossary of Terms	44
Notes	44

Introduction

The Bradford White Ultra Low NOx Atmospheric Vent Water Heater is designed to deliver a remarkable amount of hot water at up to 82% thermal efficiency in a quiet running unit with a top exhaust vent connection that allows for installation in existing locations. While this unit is vented atmospherically there is no damper required to maintain heat loss during off cycle. Several technologically advanced design features are incorporated that will require additional knowledge on the part of the qualified service provider. The information in this manual will instruct service and maintenance professionals on the function, proper diagnosis and repair of The Bradford White Ultra Low NOx Atmospheric Vent Water Heater.

The Bradford White Ultra Low NOx Atmospheric Vent Water Heater uses an ultra low NOx premix power burner located at the top of the water heater to direct a turbulent flame down into the water backed combustion chamber. This turbulence causes a thorough mixing of gas and air for optimum combustion. The combustion gases then travel through a two pass flue system keeping the gases moving at a high velocity. The combination of high turbulence and velocity results in an optimum transfer of heat from the flue gases into the water.

Burner operation is controlled using an electronic ignition module. The module monitors the status of the electronic thermostat, blocked vent limit switch, flame sensor to control output voltage to blower motor, spark rod and gas valve. The module contains programming which determines the sequence of operation and timings for purge periods, trial for ignition, flame sensing and lockout. The module will also provide diagnostic information to help in determining the cause of system lockouts.

The contents in this manual are detailed informational tools to assist in the proper diagnosis of the Ultra Low NOx Atmospheric Vent Water Heater operational faults. Please read this service manual completely and record as much information regarding the Ultra Low NOx Atmospheric Vent Water Heater operation and installation specifics related to any concerns.

How to Use This Manual

It is intended for this manual to be used by qualified service personnel for the primary purpose of troubleshooting analysis and repair of the Bradford White UCG100H399. Understanding the sequence of operation section of this manual will contribute greatly to troubleshooting this product.

An "Installation Check List" is shown towards the end of this manual. Compare the installation against the installation check list to confirm all requirements are met.

A "Service Report" is shown towards the end of this manual. Completing this form will assist in the troubleshooting efforts. Should you need to call for technical support, please provide the information shown on this form to the support technician to help ensure accurate troubleshooting.

Troubleshooting begins with "System Observation" to determine failure mode as indicated by the error code on the system display. Troubleshooting continues with "Failure Modes and Probable Cause" directing the service provider to a series of test procedures to determine root cause of failure. Component replacement procedures directly follow the test procedures for a given component.

In some difficult to diagnose conditions, it may be necessary to isolate the heater from the vent system to determine root cause.

Contact Technical support immediately if diagnosis is not determined using the methods described in this service manual.

Tools Required for Service

Manometer: Two types available, a liquid "U" tube type or a digital (magna-helic) type. This device is used to measure gas and/or air pressures and vacuum.

Multi-Meter: A digital type is strongly recommended. This device is used to measure electrical values. The meter you select must have the capability to measure volts AC, volts DC, Amps, micro-amps and ohms.

Thermometer: Used to measure water temperature. An accurate thermometer is recommended.

Water Pressure Gage: Used to measure water supply pressure. Also used to determine tank pressure by adapting to the drain valve of the heater.

Jumper Leads: A length of wire (12" min.) with alligator clip at both ends.

Various Hand Tools: Pipe wrench, channel locks, open end wrench set, 12" crescent wrench, Allen wrench set, torx bit set, screw drivers (common & phillips), long reach (12") magnetic tip phillips head screw driver #2 tip, 1/4" nut driver, pliers (common & needle nose), socket set including a 1-1/16 deep well socket, wire cutters, wire strippers, wire crimpers, torpedo level, small shop vac, step ladder, and flashlight.

Features

Features of Honeywell Integrated Control System

- Attractive digital water heater display on control panel for setting and displaying the temperature setpoint. Pressing temperature UP and DOWN buttons changes the temperature setpoint. Temperature format may be displayed in °F or °C.
- Single control board with plug in wiring controls temperature, ignition, and blower operation.
- Reduced number of parts for servicing and wiring.
- Plug in wiring reduces chance of miswiring.
- Burner ignition with direct spark ignition - A high voltage spark jumps from the spark rod to the burner surface to ignite the gas. Eliminates burned out hot surface igniter replacements.
- Water heater display will show diagnostic codes in the event the water heater needs servicing. Aids in diagnosing and servicing the water heater.
- Water heater display can show previous error code history to further aid in servicing the water heater.

Specifications

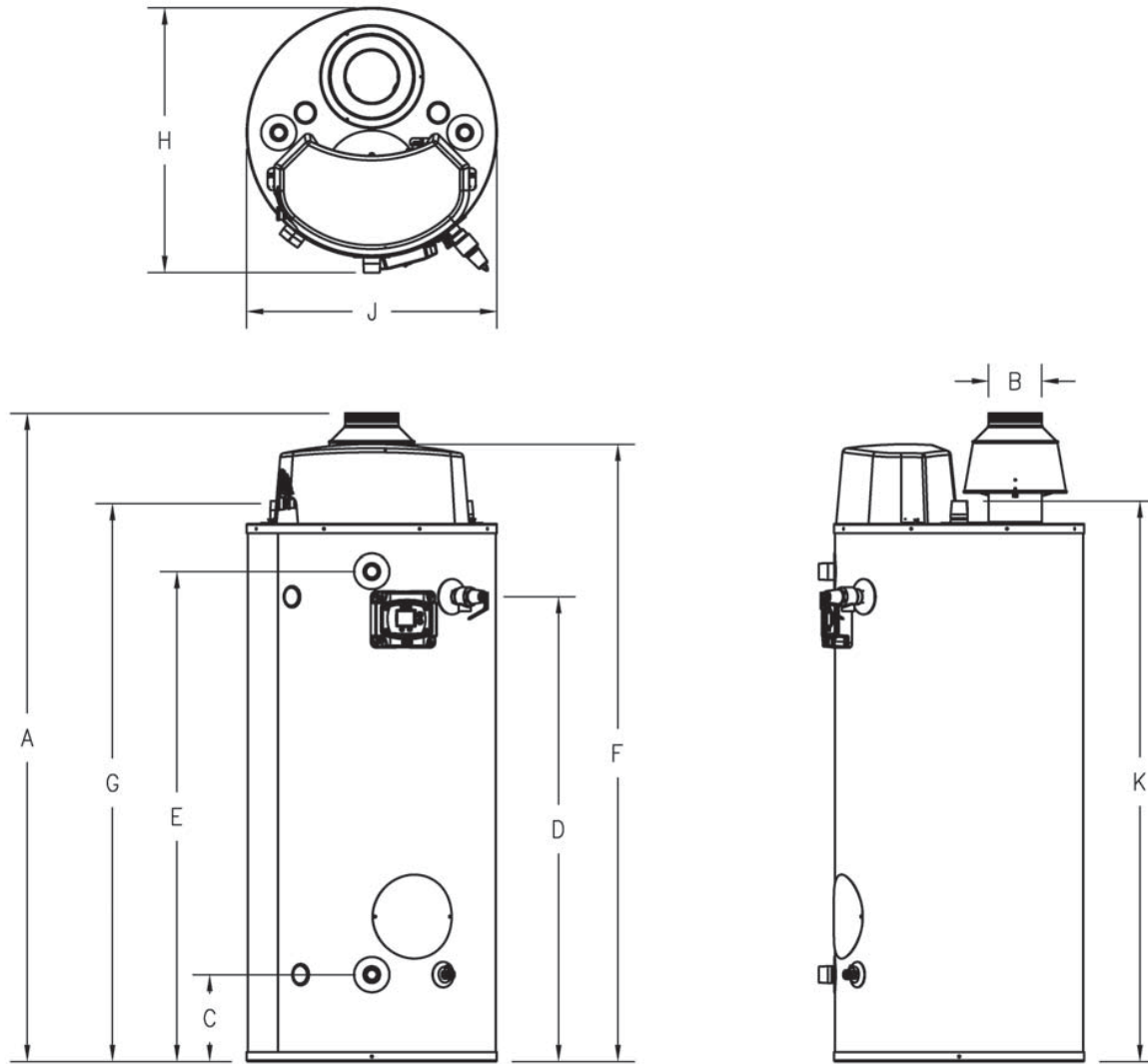

Model Description			Dimensions (INCHES)													
Model No.	Input Rate BTU/h	Storage Capacity U.S. Gallons	A Floor to Top of Vent	B Vent Dia.	C Floor to Cold Water Conn.	D Floor to T&P	E Floor to Hot Water Conn.	F Floor to Top of Water Heater	G Floor to Gas Conn.	H Depth	J Jacket Dia.	K Floor to Top Conn.	Water Conn. Dia.	Gas Conn. Dia.	Relief Valve Open	Shipping Weight (lbs)
UCG100H399	399,000	100	77 1/4	8	10	52 1/2	55 1/2	69 3/4	63 1/4	30	28 1/4	63 1/4	1 1/2	3/4	1	657
UCG80H399	399,000	80	68 3/4	8	10	44	47	61 1/4	55 3/4	30	28 1/4	55 3/4	1 1/2	3/4	1	

Model Description			Dimensions (MM)													
Model No.	Input Rate KW	Storage Capacity Liters	A Floor to Top of Vent	B Vent Dia.	C Floor to Cold Water Conn.	D Floor to T&P	E Floor to Hot Water Conn.	F Floor to Top of Water Heater	G Floor to Gas Conn.	H Depth	J Jacket Dia.	K Floor to Top Conn.	Water Conn. Dia.	Gas Conn. Dia.	Relief Valve Open	Shipping Weight (kg)
UCG100H399	117.2	371	1962	203	254	1334	1410	1772	1607	762	718	1607	38	19	25	297
UCG80H399	117.2	297	1746	203	254	1118	1194	1556	1416	762	718	1416	38	19	25	

Specifications

Power Supply	Dedicated 120 VAC, 60 Hz, 15A GFI
Gas Supply	Minimum 1" Nat (Schedule 40 black iron pipe recommended)
Approved gas Type	Natural. Unit must match gas type supplied
Gas Pressure (Nat.)	14.0" W.C. maximum static, 4.5" W.C. minimum running (recommend 7.0" W.C. min running)
Venting System	Atmospherically Vented, Type B Venting system or approved chimney. Follow the current National Fuel Gas Code requirements or in Canada, the Natural Gas and Propane Installation Code.
Minimum Clearance for Servicing	18" from top, 24" from front, 4" sides and rear.
Maximum Water Supply Pressure	150 PSI
Thermostat Sensor	11,900 Ohms @ 70°F, ECO opens @ 207°F Max. Redundant sensor for ECO. Sensor inside well for easy replacement of sensor.
Control Display	Digital display, 24 volts. temperature Range: 70-180 degree F. Used to set tank temperature (deg. F or deg. C), show operating status, display error codes, error code history, limit maximum setpoint temperature.
Control Board	Operates from 24 volt from transformer. Controls tank temperature, ignition functions, combustion blower. See ignition timings in sequence of operation for Integrated Control.
Transformer	120 VAC primary, 24 VAC secondary, 40 VA.
Spark Rod Igniter	0.22" nominal gap to the burner surface.
Flame Sensor Output	Minimum 1 micro amp. Typical range 5 to 30 micro amps.
Gas Valve	Negative regulation, 24 VAC, ½" PSI max., 4.5" W.C. minimum running inlet.
Vent Safety Switch	Normally closed, opens @ 240°F, manual reset.
Blower	120 VAC, 60 Hz, 1.5-3.5 amps, 8000 RPM
Combustion Levels	CO ₂ : 8-11%, CO: less than 0.04% (400 PPM) air free

Specifications

Vent Tables (Intake Only)

<i>Model Number</i>	<i>Max Intake Vent Length (feet) 3"</i>	<i>Max Intake Vent Length (feet) 4"</i>
UCG100H399	25	50
UCG80H399	25	50

WARNING! The UCG(80,100)H399 model is not approved for 2 inch diameter vent pipe. Venting with 2 inch pipe may result in damage to the water heater or cause an unsafe condition. **DO NOT** use 2 inch Vent Air Intake Pipe!

Determining required intake vent length

1. Determine the total length of straight vent pipe (in feet) required for the intake.
2. Add 5 feet of venting for every 90° elbow.
3. Add 2 ½ feet of venting for every 45° elbow.
4. **Total vent length cannot exceed “Max Intake Vent Length” on the venting table shown above.**

Example of Total Intake Vent Length for UCG100H399 installation:

A 3” venting system has a total of two 90-degree elbows and a total straight pipe length of 10 feet.

Equivalent vent length for elbows: 2 x 5 feet = 10 feet.

Total equivalent vent distance = 10 feet + 10 feet = 20 feet total equivalent vent length. This is below the maximum allowed distance of 25 feet for this model using 3” vent.

Sequence of Operation

1. Thermostat calls for heat.
2. Combustion blower starts.
3. Blower pre-purge period of 30 seconds.
4. Trial for Ignition. (5 seconds, 3 trials).
 - a. Flame establishing period (3 seconds), gas valve opens, sparks from spark rod to burner surface to ignite the gas.
 - b. Burner on, flame proving period (2 seconds). Requires a minimum of 1.0 microamp through flame sense rod to prove flame.
 - c. If the blocked vent safety switch contacts (normally closed) opens, then the ignition sequence will not start and an error code 67 (Vent safety switch failed to close/open) will be shown on the display.
5. Steady State Operation: Burner continues to operate until:
 - a. Thermostat circuit opens, gas valve closes, blower continues to operate for 30 second post-purge period.
 - b. If the normally closed blocked vent safety switch opens, the gas valve closes, the blower continues to operate indefinitely and error code 67 will be displayed after a couple minutes (up to 5 minutes) with "Service Needed."
6. Thermostat satisfied.
7. Gas valve closes, burner extinguished.
8. Blower post purge for 30 seconds.

Sequence of Operation

Lockout Conditions

The system will go into lock out mode for the following reasons:

1. ERROR CODE 110
 - a. Control board will go into "Soft Lockout" if the main burner cannot be lit or fails to prove flame after 3 ignition trials. The water heater display indicates a lockout condition by showing an error code number 110 with "Service Needed" in the control display window. Refer to error codes in the diagnostic section of this Service Manual. In a "Soft Lockout" condition, the control will wait for 15 minutes and then make 3 more attempts to light the main burners. Soft lockout reset is accomplished by depressing the lower right button under "Reset" for 3 seconds.
2. ERROR CODE 80
 - a. If the top of the tank should exceed 207°F, then the high limit control will shut off the burner and the water heater will go into a "Hard Lockout." Error code 80 will be shown in the water heater display. The control can only be reset in the "Service Mode," which is detailed in the "Troubleshooting" section of this Service Manual.
3. ERROR CODE 67
 - a. If the vent safety switch located on the draft hood should open, the gas valve will close, the blower will post-purge and error code 67 will appear on the display. The lockout condition will reset once the problem is corrected and the switch reset. Refer to "Vent Safety Switch Testing and Replacement" in this Service Manual.

CONNECTION/WIRING DIAGRAM

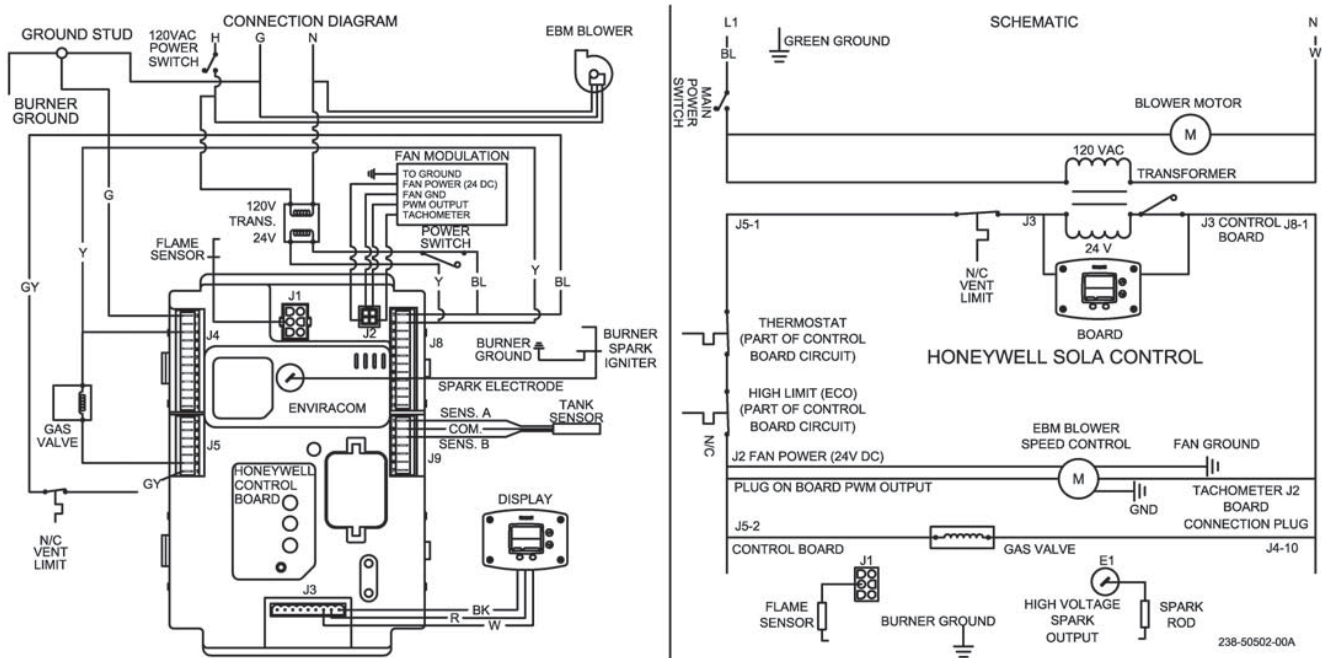

Troubleshooting

System Observation for Models with Direct Spark Ignition

Water Heater Fault: Water heater does not operate
 Display Error Code: Water heater display does not operate - blank display

Check main power supply to water heater – fuse, circuit breaker, plug receptacle, line cord or wiring to water heater.

Check to make sure switch on front of control panel is in the ON position.

Verify primary voltage at the transformer.

Verify secondary voltage at the control board.

! WARNING
 120 volt potential exposure. Use caution making voltage checks to avoid personal injury.

! CAUTION
 Use caution not to damage connectors when making voltage measurements or jumping terminals

Refer to control board illustration. Voltage at transformer across black and white wires should be 110-120 VAC. Check line cord with volt meter. Replace line cord if defective.

Refer to control board illustration. Voltage at connector location J8 across blue and yellow wires should be 24VAC. If not, check transformer. Replace transformer if defective.

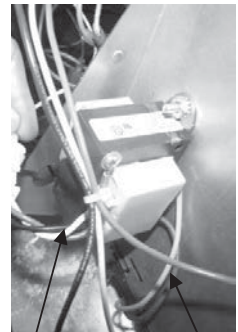

Black & White wires.

Yellow & Blue wires.

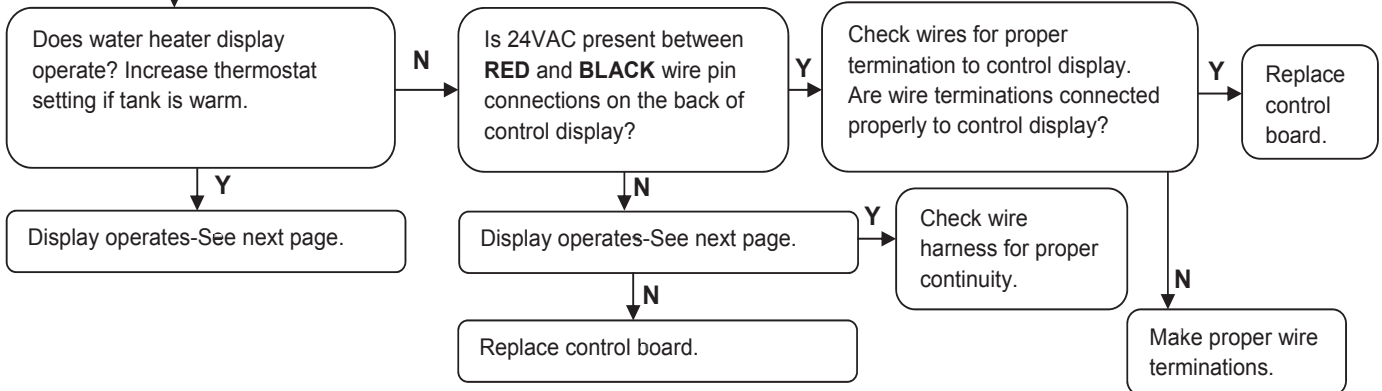
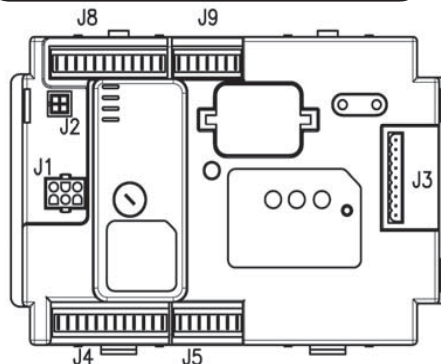

Troubleshooting

CAUTION

Use caution not to damage connectors when making voltage measurements or jumping terminals

WARNING

120 volt potential exposure. Use caution making voltage checks to avoid personal injury.

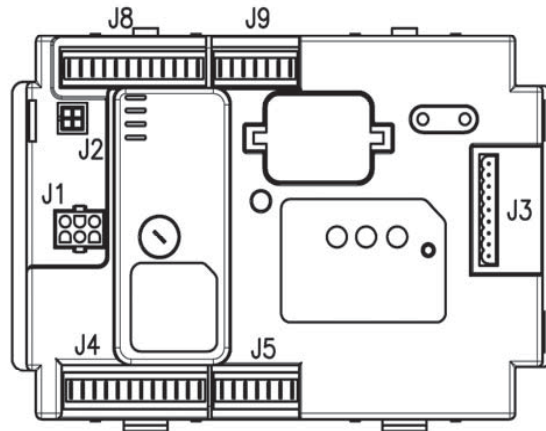
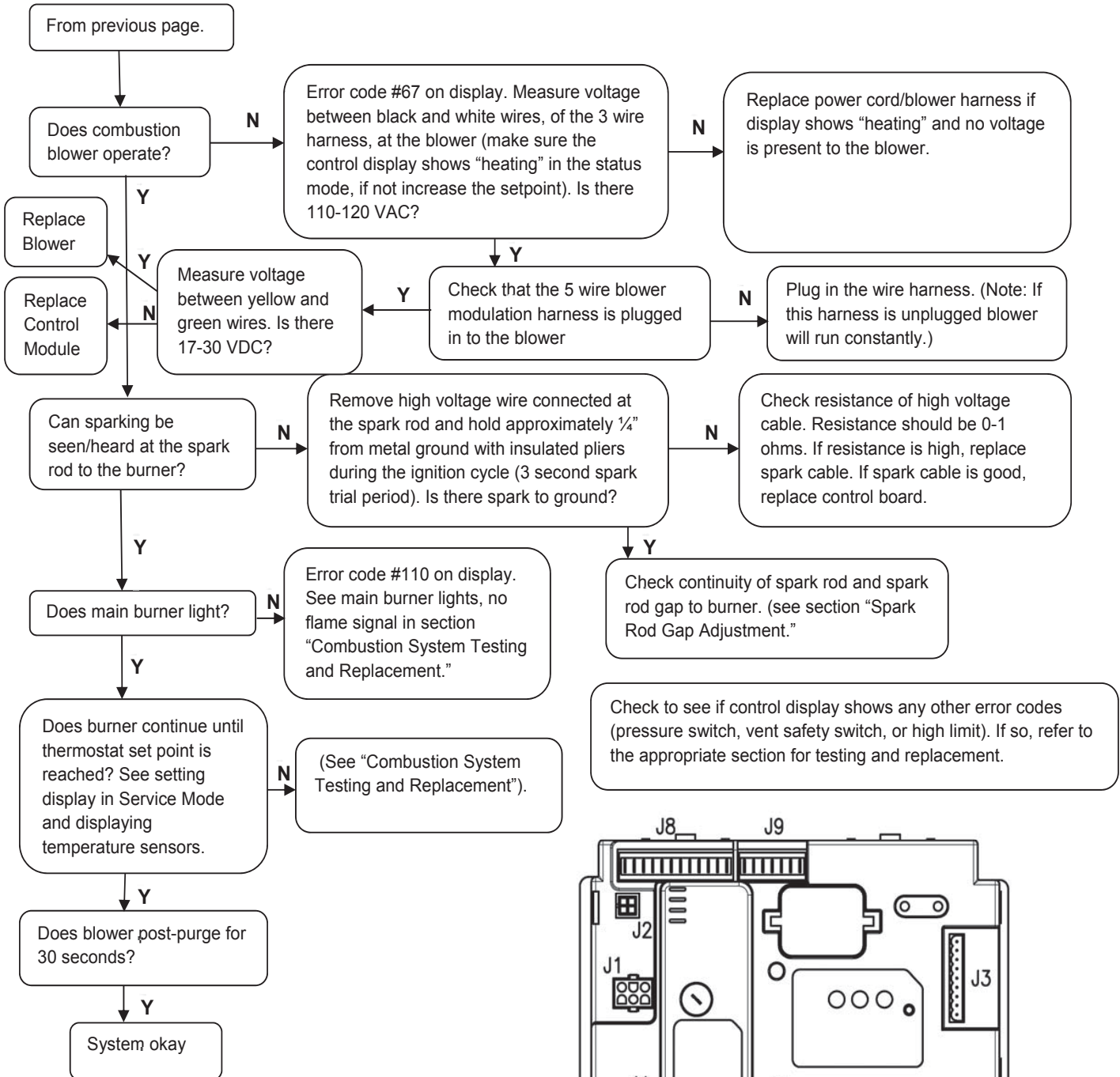

Troubleshooting

Step 1: Press and hold the lower right button under “Next” in the lower right display for at least 3 seconds.

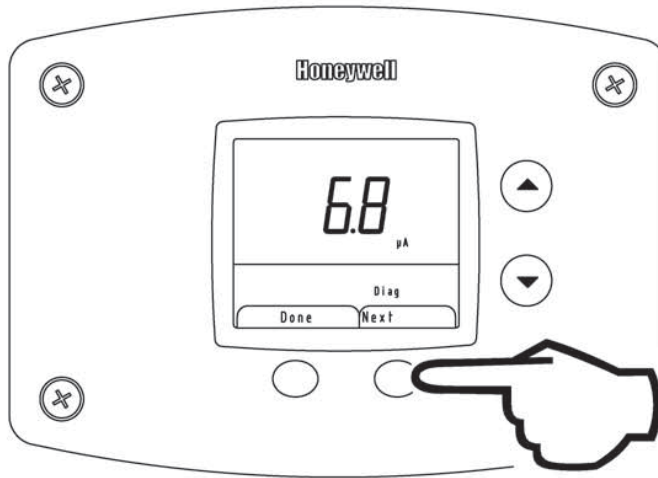

PRESS NEXT BUTTON FOR
3 SECONDS TO ENTER

WARNING

The following procedure is for service and installation personnel only. Resetting lockout conditions without correcting the malfunction can result in a hazardous condition.

Step 2: The display will show the flame sense current in microamps when the burner is operating.

Step 3: Press the lower right “Next” button and the display will show flash and show the number of any Alert codes. These are not currently used.

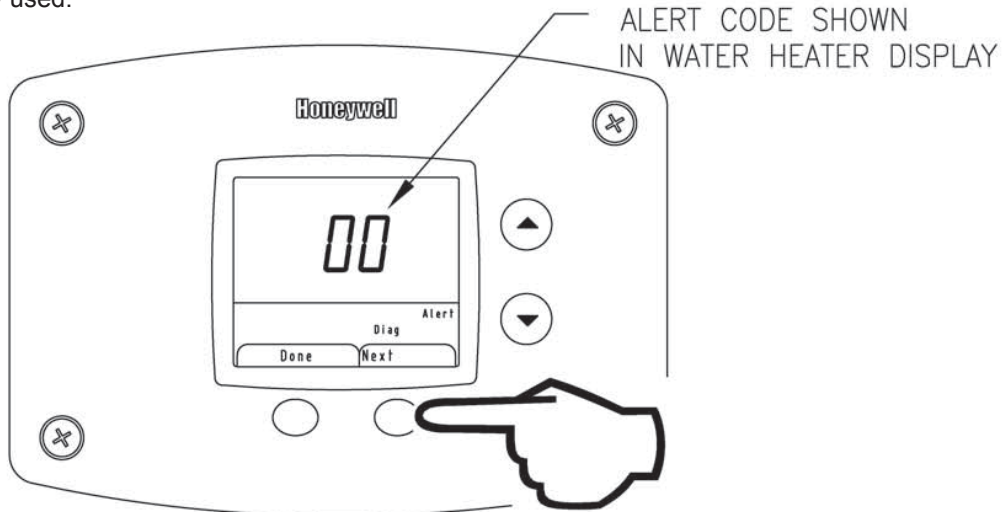

Troubleshooting

Step 4: Press lower right "Next" button and the display will flash and show the number of any Lockout codes.

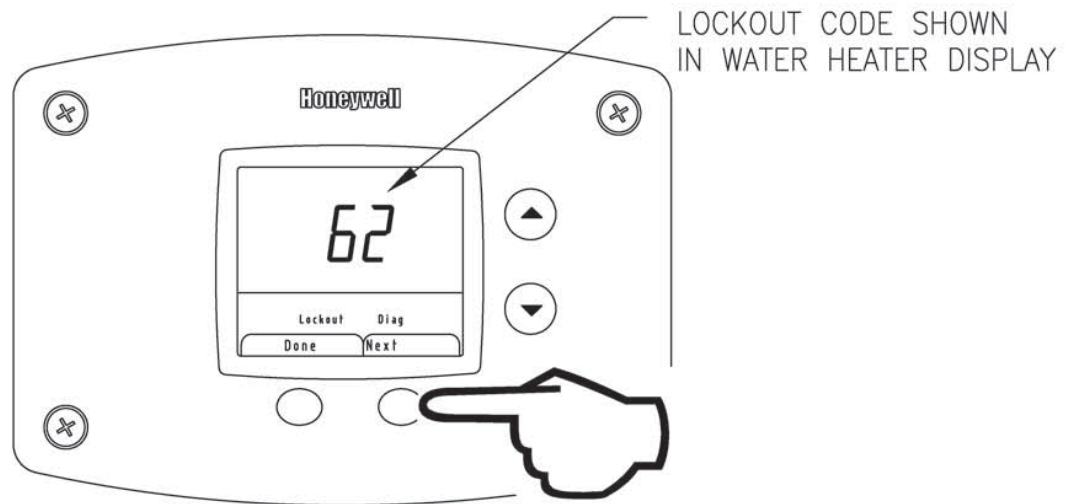

Step 5: Press lower right "Next" button and the display will show the temperature sensor reading.

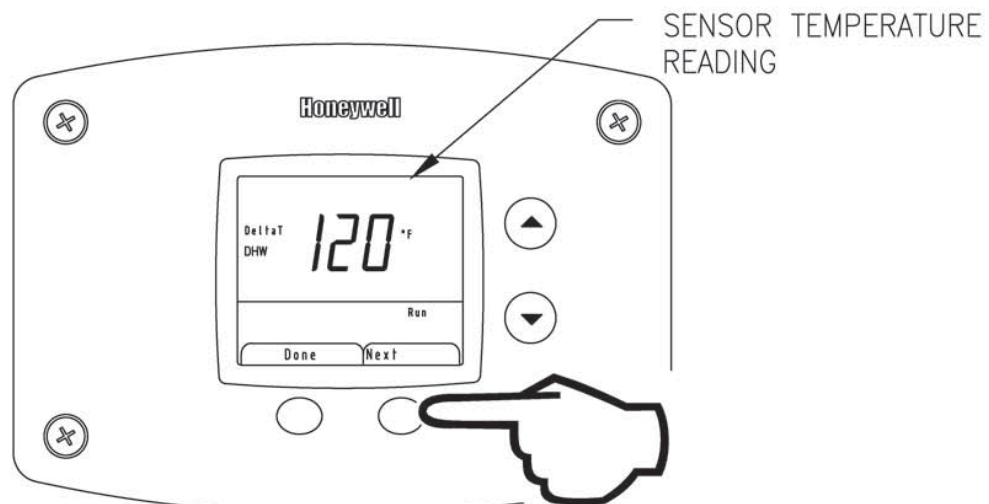

Step 6: End of screens in Diagnostic Mode. Press "Done" button on lower left to exit Diagnostic Mode back to DHW setpoint in the User Mode.

NOTICE

The screens will stay in the Diagnostic Mode for 12.5 minutes after the last button press for viewing unless "Done" button is pressed to exit Diagnostic Mode.

Troubleshooting

DIAGNOSTIC ERROR CODES AND TROUBLESHOOTING PROCEDURES FOR EF100T399 MODELS WITH HONEYWELL LOW FIRE START CONTROL SYSTEM

Error Code	Definition of Code	Cause of Problem and Actions Taken to Correct
No code – blank display		<ul style="list-style-type: none"> • Check power supply to the water heater. • Make sure water heater is plugged in and the breaker is on. • Check if there is 120 volts power supply to the LINE connections on the control board. • If 120 volts is present, check for 24 volts output to SECONDARY terminals on the Control Board. • Check for loose wires, defective transformer. • Check wire harness connections from display to the control board.
3-48, 58-60	Internal Faults	<ul style="list-style-type: none"> • Verify wiring to the control board with wiring diagram. • Check power supply to make sure voltage and frequency is correct. • Check for 24 volts from the transformer to the control board. • Reset module by interrupting power or pressing the reset button on the module.
49	Voltage too low or high	<ul style="list-style-type: none"> • Measure the incoming line voltage. • Voltage should be 115-125 volts. • If the voltage is not within this range or there is drastic fluctuation, then have the incoming power supply checked. • If the line voltage is satisfactory, check the output from the transformer to make sure it is 22-26 volts. • Replace transformer or wiring if defective.
53	AC Inputs phase reversed	<ul style="list-style-type: none"> • Check the module and display connections. • Check the module power supply and make sure that frequency, voltage and VA capacity of the transformer meet specifications. • Check to make sure the wiring connections on the control module from terminals J4-10 and J8-2 are connected together.
62	Fan speed not proved	<ul style="list-style-type: none"> • Check the blower modulation wire harness connection from the blower to the control module at J2 connection. • Make sure the pin terminals make solid contact. • Measure the resistance of each wire in the wire harness from the terminal ends. • Replace wire harness if defective. • Check if there is 17-30 volts DC between the yellow and green wires on the blower 5 wire harness. • Check if there is 17-30 VDC between the yellow and green wires on the blower 5 wire harness.
67	ILK Off (Interlock Off)	<ul style="list-style-type: none"> • Check wiring to the normally closed blocked vent safety. • Use a voltmeter to find out if the blocked vent safety switch has opened. • If so, determine the cause (blocked vent terminal, recirculation). • If limit switch is closed, check wiring for shorts. • Measure continuity. • If limit switch and wiring check O.K., replace control module.

Troubleshooting

Service Procedure I:

80	High Limit (Overheat Condition)	<ul style="list-style-type: none"> • Check the wiring from the sensor to the control module. • Measure the resistance of each outside wire to the center wire. • If either outside wire has a much different resistance reading, replace the sensor. • Make sure the sensor is securely held inside the well with the clip. • If the problem persists and the sensor and wiring check O.K., then replace the control module.
93	DHW/TEMP Sensor Fault	<ul style="list-style-type: none"> • Check the sensor wire harness from the sensor to the control module. • Make sure there are no loose connections to the control plug. • Check the resistance reading from each of the outside wires to the center (common) wire. • If the ohm readings are not fairly close, replace the sensor. • Replace the control module if the problem persists and the sensor and wire connections are not defective.
105	Flame detected out of sequence	<ul style="list-style-type: none"> • Check to see if flame is present inside the combustion chamber before or after the ignition cycle. • If so, check to make sure the gas valve is wired correctly. • Check for voltage at the gas valve connection. • Replace the gas valve if defective. • If no flame is visible outside of the ignition sequence/run cycle, then make sure the flame sensor is wired to the correct terminal. • Make sure the ignition cable is not crossing the flame sensor wire or ignition ground wires. • If problem persists and all other checks have been verified, replace the control module.
110	Ignition Failure Occurred	<ul style="list-style-type: none"> • Burner failed to light or stay lit after 3 retries. • Hold condition – will reattempt ignition after 15 minute waiting period. • Check gas valve wiring and gas valve operation during the ignition cycle. • If burner lights but quickly goes out, check the flame sensor wire or the flame sensor. • If the flame sensor rod is badly corroded with deposits, clean with sandpaper or replace. • Check the inlet gas supply to make sure the pressure is sufficient and does not drop after the gas valve opens. • Make sure the combustion blower is operating during the ignition and run cycle. • Check the venting system to make sure the inlet and exhaust terminals and venting system is not blocked.
122	Light-off Rate Proving Failed	<ul style="list-style-type: none"> • If blower speed is not verified from the PWM (Pulse Width Modulation) signal within 5 minutes, the previously described error code “62” changes from a hold condition to this lockout code condition. • Check the harness and pin terminals for a good connection to the control module. • Replace the control module if the wire harness is good.
137	ILK Open (Interlock Open)	<ul style="list-style-type: none"> • Check if blocked vent safety switch is open. • If switch checks O.K., replace control module

Thermostat Circuit Testing and Replacement

IMPORTANT NOTE: This procedure assumes a cool tank.

Condition: Water heater not operating. Display shows error code "93" (sensor reading faulty)

Unplug or disconnect electrical power to the water heater.

Check continuity of wire harness to sensor. Resistance of harness should be close to 0 ohms. Replace wire harness if high resistance is measured (over .5 ohms). Check wires for intermittent connections, shorts, frayed insulation. Replace if necessary.

If wire harness is O.K., check sensor resistance detailed in "Appendix – A: sensor resistance at various temperatures" at the end of the thermostat testing and replacement section. Replace sensor if needed.

Turn power ON to water heater. Run water heater through heating cycle and verify proper operation. Sensor temperature can be viewed when burner shuts off (see section on viewing the display in "Service Mode").

Condition: Water heater not operating. Display shows error code "80" high water temperature (over 200 °F).

WARNING
Do not reset the display from the hard lockout state without correcting the cause of the overheating condition.

Turn power OFF. Draw water to cool tank below 120 °F

Check sensor. Sensor is held in place with a clip fastened to the well (see photo). Check sensor wire for potential damage or breaks in the wire insulation. Is the sensor fully inserted into the well?

N

Y

Checking continuity of sensor (disconnected from control board).

! WARNING

120 volt potential exposure. Use caution making voltage checks to avoid personal injury.

! CAUTION

Use caution not to damage connectors when making voltage measurements or jumping terminals

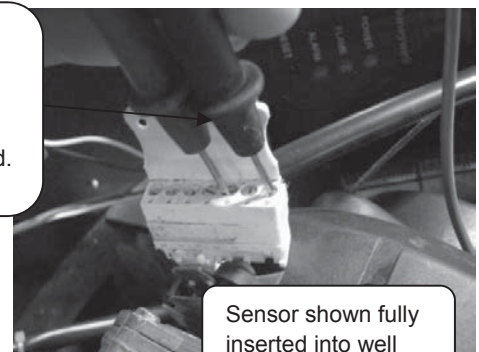

Sensor shown fully inserted into well

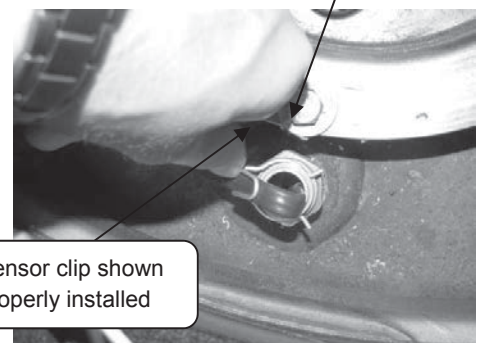

Sensor clip shown properly installed

If sensor clip is damaged replace clip. Replace sensor if damaged.

Continued on next page.

Check sensor resistance (see Sensor Resistance Testing, following section).

Service Procedure I: Thermostat Circuit Testing and Replacement

Condition: Water heater not operating. Display shows error code "80" high water temperature (over 200 °F) (continued from previous page).

Once cause of overheating condition has been diagnosed and corrected, the control may be reset.

- Reconnect and switch on power to the water heater.
- Press button under "Reset" and hold for 3 seconds.
- Set thermostat to the desired setting.
- Water heater will start.
- Monitor temperatures for one complete heating cycle making sure the maximum tank temperature remains below 200 °F.

WARNING

Do not operate water heater without verifying that the overheating condition has been corrected.

This water heater is equipped with a manual reset type gas shutoff device designed to shut off the gas to the burners if excessive water temperature occurs. To reset the control, press the lower right button under "RESET" in the display for 3 seconds.

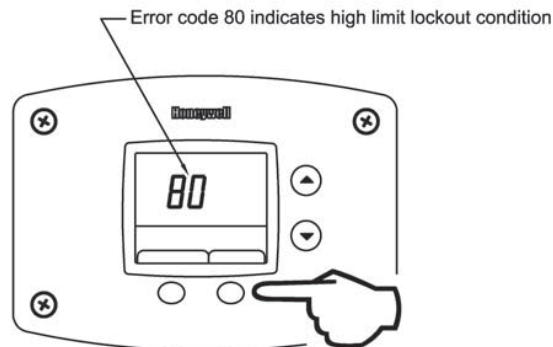

Step 1: Press for 3 seconds to reset control.

Service Procedure I: Thermostat Circuit Testing and Replacement

APPENDIX-A Sensor Resistance at Various Temperatures

Be careful when making voltage measurements or jumping terminals not to damage or deform connectors or connector pins.

Draw water from the T&P valve. Compare temperature with temperature ohms chart below.

Example: If the temperature is 84°F, then the resistance through the sensor would be 8449 (see shaded area).

Note: Sensor resistance increases as the temperature falls.

In Degrees F										
°F	0	1	2	3	4	5	6	7	8	9
40	26109	25400	24712	24045	23399	22771	22163	21573	21000	20445
50	19906	19383	18876	18383	17905	17440	16990	16553	16128	15715
60	15314	14925	14548	14180	13823	13477	13140	12812	12494	12185
70	11884	11592	11308	11032	10763	10502	10248	10000	9760	9526
80	9299	9078	8862	8653	8449	8250	8057	7869	7685	7507
90	7333	7165	7000	6839	6683	6531	6383	6238	6098	5961
100	5827	5697	5570	5446	5326	5208	5094	4982	4873	4767
110	4663	4562	4464	4368	4274	4183	4094	4006	3922	3839
120	3758	3679	3602	3527	3453	3382	3312	3244	3177	3112
130	3048	2986	2925	2866	2808	2752	2697	2643	2590	2538
140	2488	2439	2391	2344	2298	2253	2209	2166	2124	2083
150	2043	2004	1966	1928	1891	1856	1820	1786	1753	1720
160	1688	1656	1625	1595	1566	1537	1509	1481	1454	1427
170	1402	1376	1351	1327	1303	1280	1257	1235	1213	1191
180	1170	1150	1129	1110	1090	1071	1053	1035	1017	999
190	982	965	949	933	917	901	886	871	857	842
200	828	814	801	788	775	762	749	737	725	713

In Degrees C										
°C	0	1	2	3	4	5	6	7	8	9
0	32648	31026	29495	28049	26682	25389	24166	23010	21915	20879
10	19898	18968	18088	17253	16461	15710	14998	14322	13680	13071
20	12492	11942	11419	10922	10450	10000	9572	9165	8778	8409
30	8057	7722	7403	7099	6808	6532	6268	6016	5775	5546
40	5327	5117	4917	4726	4543	4368	4201	4042	3889	3742
50	3602	3468	3340	3217	3099	2986	2878	2774	2675	2579
60	2488	2400	2316	2235	2157	2083	2011	1942	1876	1813
70	1752	1693	1637	1582	1530	1480	1432	1385	1340	1297
80	1256	1216	1177	1140	1105	1070	1037	1005	974	944
90	916	888	861	835	810	786	763	741	719	698

Service Procedure I: Thermostat Circuit Testing and Replacement

Thermostat Sensor (Thermister) Replacement Procedure

- Step 1. Position main power switch to "OFF"
- Step 2. Disconnect (unplug) water heater from 120 volt power source.
- Step 3. Un-latch and remove top surround cover from top of heater.
- Step 4. Disconnect temperature sensor from control (see photos below).
- Step 5. Unclip sensor from well and pull sensor to remove, do not remove well (see picture).
- Step 6. Install new sensor assembly into well and reinstall sensor clip.
- Step 7. Reconnect the sensor connector to the control board and route the wire harness through the same path that it was removed.
- Step 8. Restore 120 volt power supply and water supply to water heater, check and repair any leaks found. Confirm proper operation following the lighting instructions on the lighting instruction label or the lighting instruction located in the installation and operating instruction manual.
- Step 9. Replace surround cover on top of heater.



120 volt potential exposure. Isolate the appliance and reconfirm power is disconnected using a multi-meter.

Disconnect sensor harness from control board

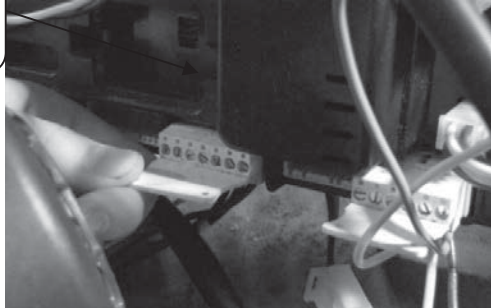

Sensor shown fully inserted into well

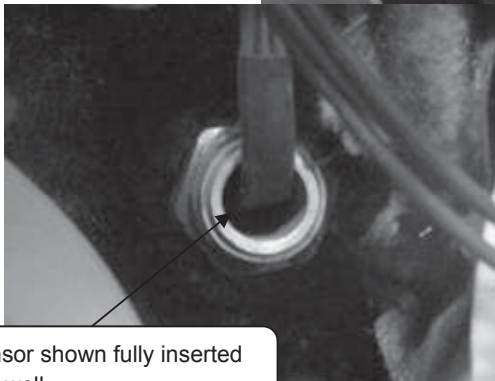

Sensor clip shown properly installed



Service Procedure II: Combustion System Testing and Replacement

Observe burner operation through the sight glass located on the combustion insert mounting flange. Normal burner operation should ignite smoothly, without evidence of coughing or huffing upon ignition. The burner flame should be a blue flame near the burner surface in a uniform flame pattern. Occasional yellow or white streaks are normal.

Note: On this high input model that uses metal fiber mesh burner a red glow from the burner surface is normal.

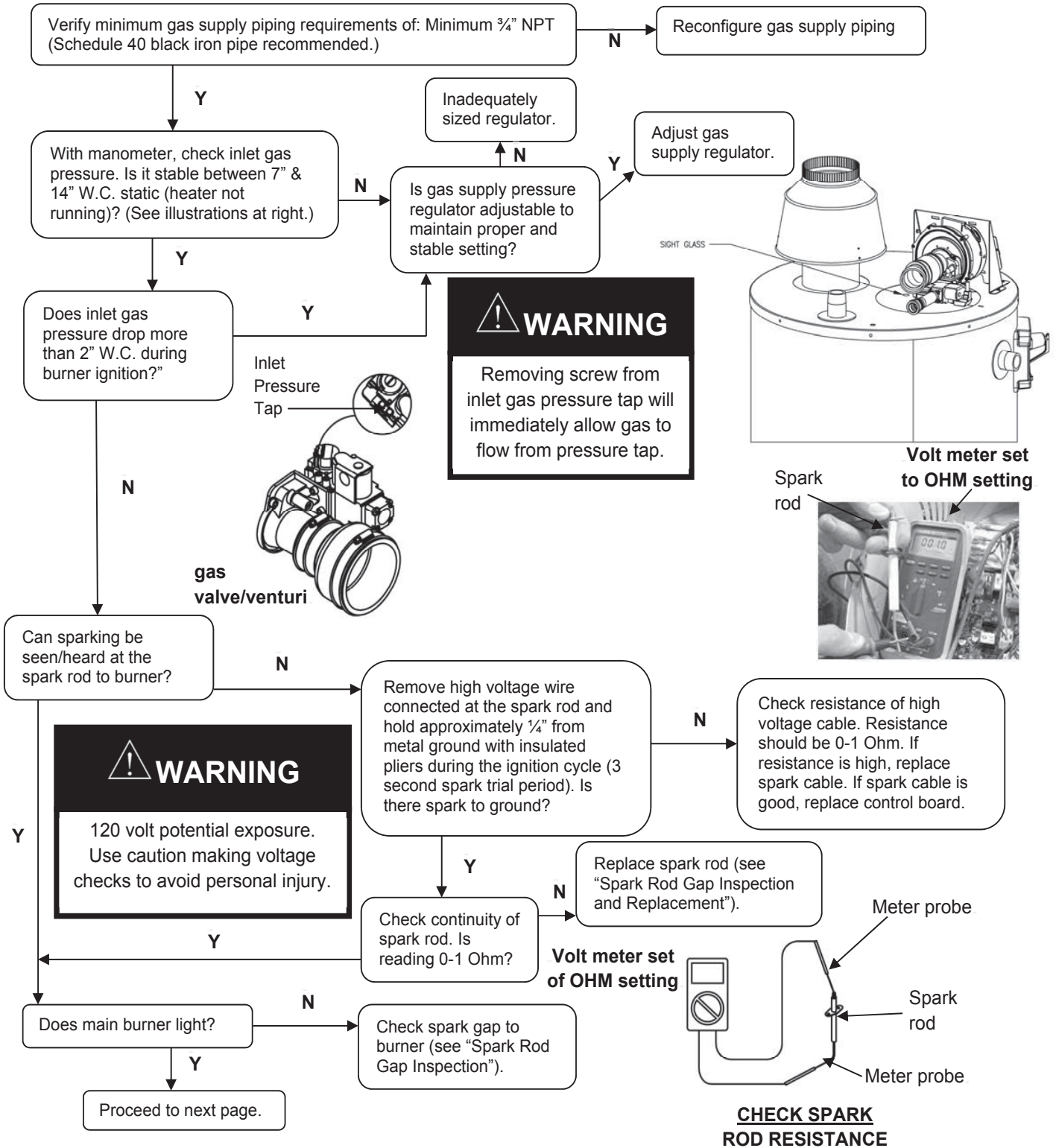

Service Procedure II: Combustion System Testing and Replacement

Observe burner operation through the sight glass located on the combustion insert mounting flange. Normal burner operation should ignite smoothly, without evidence of coughing or huffing upon ignition. The burner flame should be a blue flame near the burner surface in a uniform flame pattern. Occasional yellow or white streaks are normal.

Note: On this high input model that uses metal fiber mesh burner a red glow from the burner surface is normal.

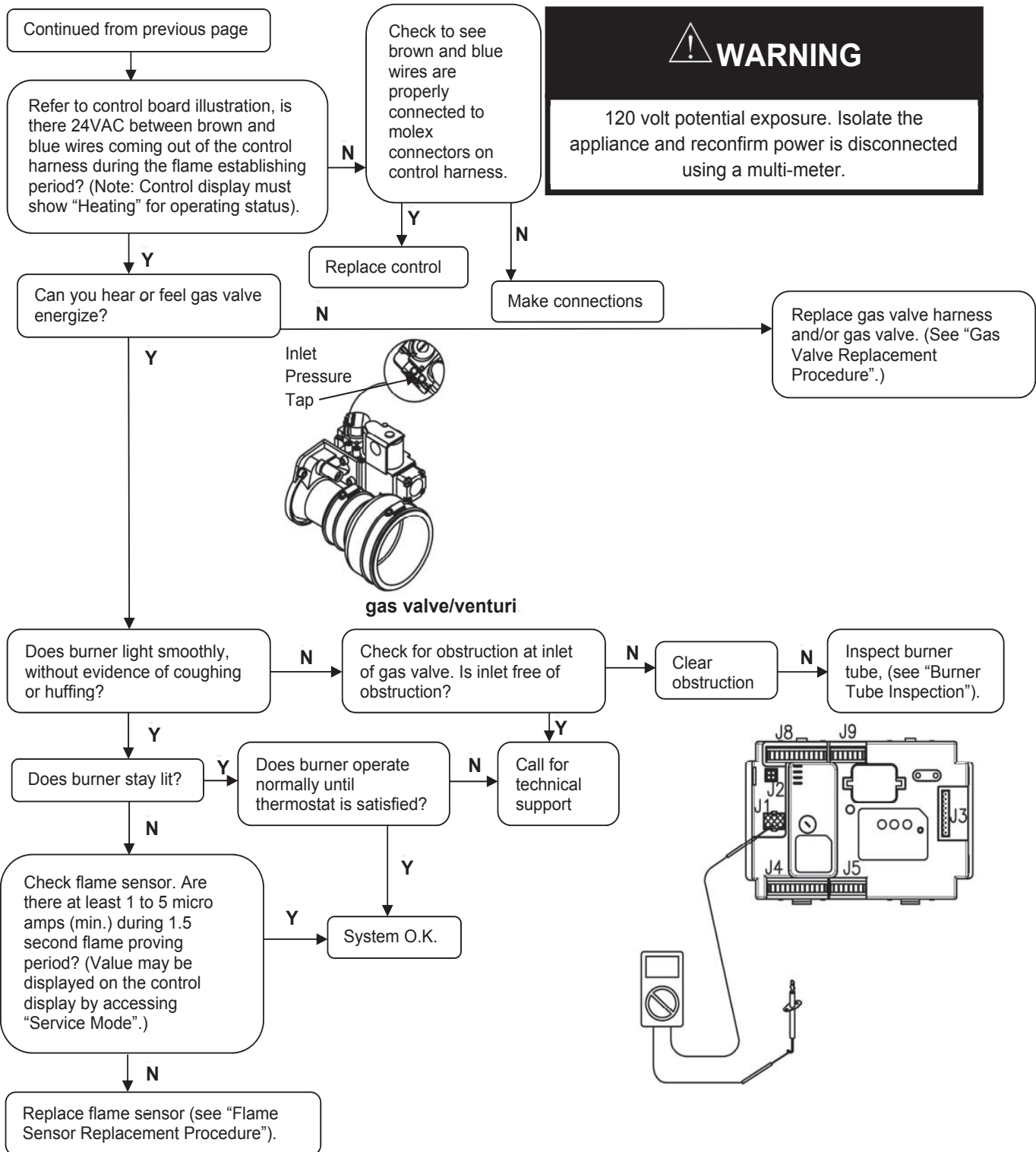

Service Procedure II: Combustion System Testing and Replacement

WARNING

Heater components may be HOT when performing the following steps in this procedure. Take necessary precaution to prevent personal injury.

Combustion System Removal Procedure

- Step 1. Position main power switch to "OFF".
- Step 2. Disconnect (unplug) water heater from 120 volt power source.
- Step 3. Turn off gas supply to water heater.
- Step 4. Un-latch and remove surround cover from top of heater.
- Step 5. From the gas valve, disconnect the gas connection, PVC intake venting, Silicone tubing and wire harness.
- Step 6. Disconnect wire harnesses flame sensor, gas valve, and blower. Disconnect high voltage cable from spark rod connection.
- Step 7. Remove the 5 bolts ($\frac{1}{2}$ " socket) holding the burner mounting insert in place.
- Step 8. Carefully remove combustion assembly with gasket from water heater.
- Step 9. See next page for combustion system installation procedure.

WARNING

120 volt potential exposure. Isolate the appliance and reconfirm power is disconnected using a multi-meter.

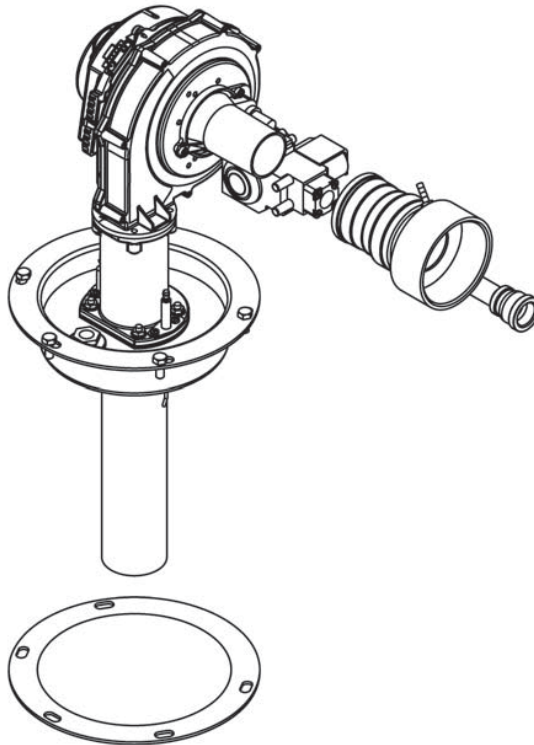

Service Procedure II: Combustion System Testing and Replacement

Combustion System Replacement Procedure

- Step 1. Fully inspect burner mounting insert gasket for the following:
- a) Tears
 - b) Missing material
 - c) Cracks
 - d) Dirt or debris
 - e) Other imperfections that would inhibit proper seal

If gasket is NOT affected by any of the above, gasket replacement is not required.

- Step 2. Install combustion assembly using new gasket or fully inspected gasket from step 1. Secure combustion assembly at the burner mounting insert using screws from step 7 on previous page. Tighten screws evenly.
- Step 3. Reconnect high voltage cable to spark rod, flame sensor, blower and gas valve.
- Step 4. Reconnect PVC intake venting, gas supply and silicone tubing to gas valve. Turn on gas supply to heater and check for gas leaks, repair any gas leaks found.
- Step 5. Restore 120 volt power supply to water heater and confirm proper operation following the lighting instructions on the lighting instruction label or the lighting instruction located in the installation and operating instruction manual.
- Step 6. Replace surround cover on top of water heater.

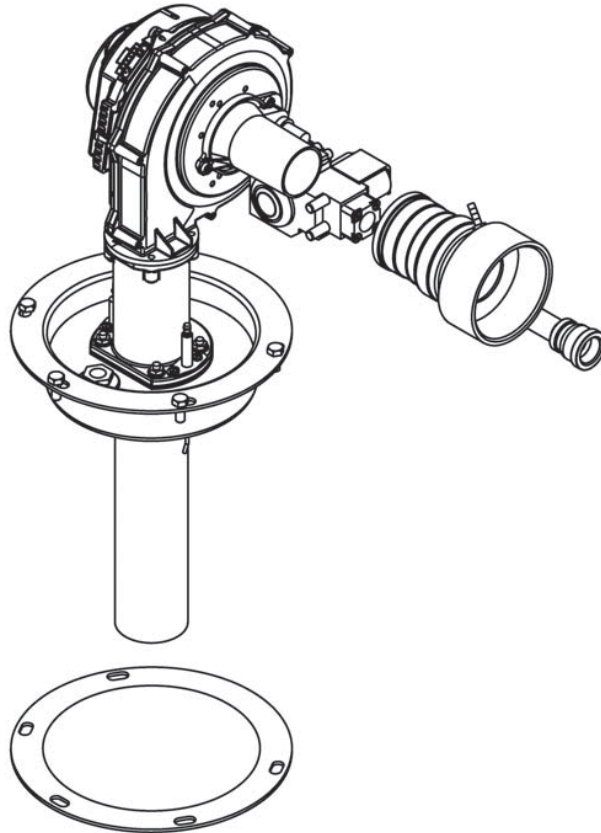

Service Procedure III: Burner Tube Inspection and Replacement

WARNING

Heater components may be HOT when performing the following steps in this procedure. Take necessary precaution to prevent personal injury.

Burner Tube Removal Procedure

- Step 1. Position main power switch to "OFF".
- Step 2. Disconnect (unplug) water heater from 120 volt power source.
- Step 3. Turn off gas supply to water heater.
- Step 4. Un-latch & remove surround cover from top of heater.
- Step 5. From the gas valve, disconnect the gas connection, PVC intake venting, wire harness and silicone tubing.
- Step 6. Disconnect wire harness from blower assembly.
- Step 7. Remove the two screws holding each the spark rod and flame sensor in place (long reach magnetic Phillips screw driver). Carefully remove spark rod and flame sensor from combustion assembly.
- Step 8. Remove the 4 nuts (7/16" wrench) holding the burner transition in place. Lift the blower/gas valve transition assembly from burner mounting insert, remove gasket and set aside.
- Step 9. Remove burner tube from burner mounting insert. See next page for burner tube inspection procedure.

WARNING

120 volt potential exposure. Isolate the appliance and reconfirm power is disconnected using a multi-meter.

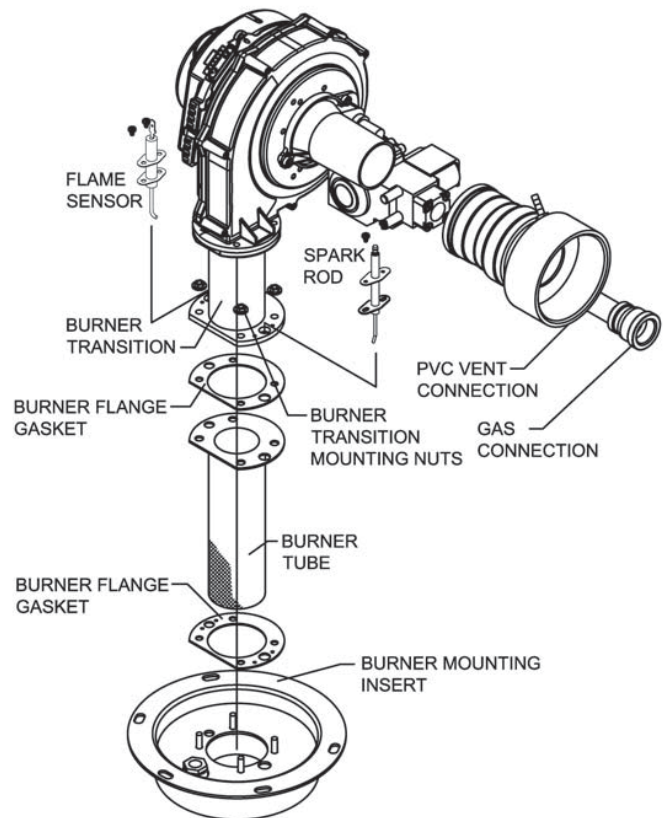

Service Procedure III: Burner Tube Inspection and Replacement



Heater components may be HOT when performing the following steps in this procedure. Take necessary precaution to prevent personal injury.

Burner Tube Inspection

- Step 1. **Inspect burner tube as follows (Acotech metal fiber mesh burner).**
- Outer fiber mesh should be uniform with no tears or deterioration.
 - Gently squeeze burner tube, Burner tube should feel firm without any soft areas around the sides or at the bottom.
 - Visually inspect inside burner tube, Burner tube should be intact with no areas of deterioration. Ports should be free of any debris.
- Step 2. If burner tube is affected by any of the above, replacement is required. Refer to burner tube replacement procedure below.

Burner Tube Replacement Procedure

Note: Provide the model and serial number for the correct replacement burner.

- Step 1. Fully inspect burner flange gaskets, igniter and flame sensor gaskets for the following:
- Tears
 - Missing material
 - Cracks
 - Dirt or debris
 - Other imperfections that would inhibit proper seal
- If gaskets are NOT affected by any of the above, gasket replacement is not required.
- Step 2. Install burner tube with gaskets into burner mounting insert. Be sure gasket surfaces are free of debris.
- Step 3. Reconnect the blower/gas valve/transition assembly to burner mounting insert. Secure using nuts from step 8 on previous page.
- Step 4. Carefully reinstall flame sensor with gasket and spark rod with gasket and secure with screws from step 7 on previous page. Reconnect wire harnesses to sensor and igniter.
- Step 5. Reconnect wire harnesses to blower motor and to gas valve.
- Step 6. Reconnect PVC intake venting, gas supply and silicone tubing to gas valve. Turn on gas to heater and check for gas leaks, repair any gas leaks found.
- Step 7. Restore 120 volt power supply to water heater and confirm proper operation following the lighting instructions on the lighting instruction label or the lighting instruction located in the installation and operating instruction manual.
- Step 8. Replace surround cover on top of water heater.

Service Procedure IV: Gas Valve Replacement

Gas Valve Replacement Procedure

- Step 1. Position main power switch to "OFF".
- Step 2. Disconnect (unplug) water heater from 120 volt power source.
- Step 3. Turn off gas supply to water heater.
- Step 4. Un-latch & remove surround cover from top of heater.
- Step 5. From the gas valve, disconnect the gas connection, PVC venting, wire harness and silicone tubing.
- Step 6. Remove the 2 to 3 gas valve mounting screws (Torx bit) located as shown below on the venturi mounting flange and remove gas valve from water heater.
- Step 7. Remove any residual gasket material from blower and venturi mounting flange.
- Step 8. Install new gas valve with new gasket provided. Secure gas valve in place using screws from step 6.
- Step 9. Reconnect PVC intake venting, gas supply, silicone tubing & wire harness to gas valve. Turn on gas supply to heater and check for gas leaks, repair any gas leaks found.
- Step 10. Restore 120 volt power supply to water heater and confirm proper operation following the lighting instructions on the lighting instruction label or the lighting instruction located in the installation and operating instruction manual.
- Step 11. Replace surround cover on top of water heater.



120 volt potential exposure. Isolate the appliance and reconfirm power is disconnected using a multi-meter.

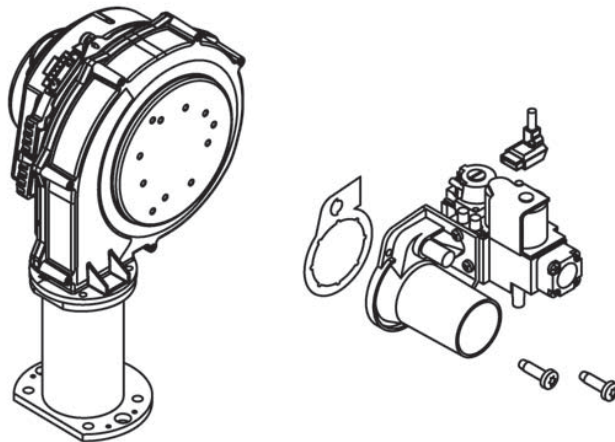

Service Procedure V: Blower Testing and Replacement

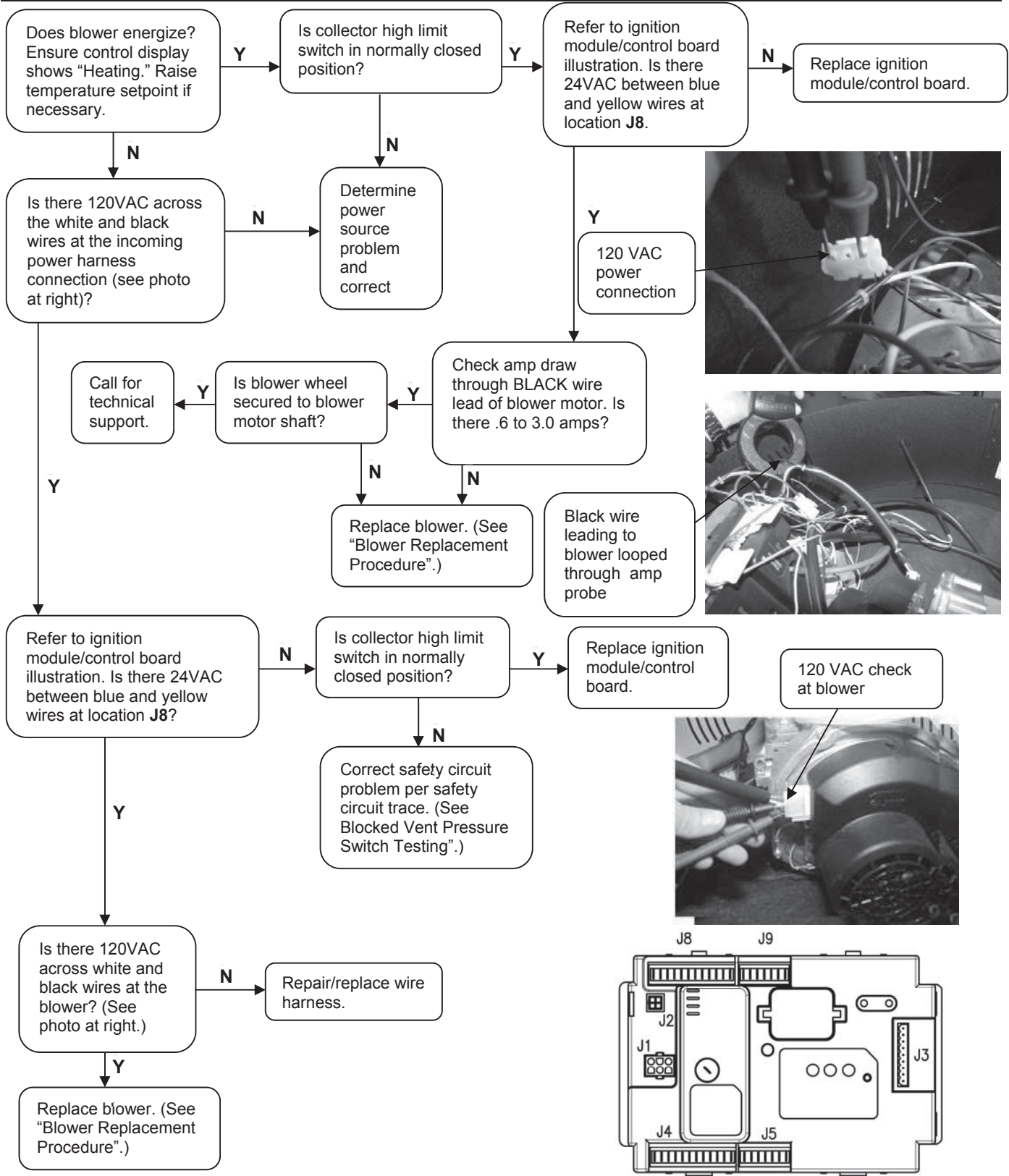

Service Procedure V: Blower Testing and Replacement

Blower Replacement Procedure

- Step 1. Position main power switch to "OFF".
- Step 2. Disconnect (unplug) water heater from 120 volt power source.
- Step 3. Turn off gas supply to water heater.
- Step 4. Un-latch & remove surround cover from top of heater.
- Step 5. Disconnect the 2 wire harnesses from blower.
- Step 6. Disconnect intake vent and gas supply from gas valve assembly.
- Step 7. Remove the 2 to 3 gas valve mounting screws (Torx bit) located on the venturi mounting flange. (Refer to page 27 for more details.)
- Step 8. Remove The 4 blower flange mounting screws (5/32 Allen wrench) and remove blower from transition flange.
- Step 9. Remove any residual gasket material from venturi mounting flange and transition flange.
- Step 10. Install new blower with new gasket provided. Secure blower in place using screws from step 8.
- Step 11. Reconnect gas valve assembly to blower with new gasket provided. Secure gas valve in place using screws from step 7.
- Step 12. Reconnect intake vent and gas line to gas valve assembly and check for gas leaks repair any leaks found.
- Step 13. Reconnect the 2 wire harnesses to blower assembly, restore 120 volt power supply & gas supply to water heater and confirm proper operation following the lighting instructions on the lighting instruction label or the lighting instructions located in the installation and operating instruction manual.
- Step 14. Replace surround cover on top of water heater.



120 volt potential exposure. Isolate the appliance and reconfirm power is disconnected using a multi-meter.

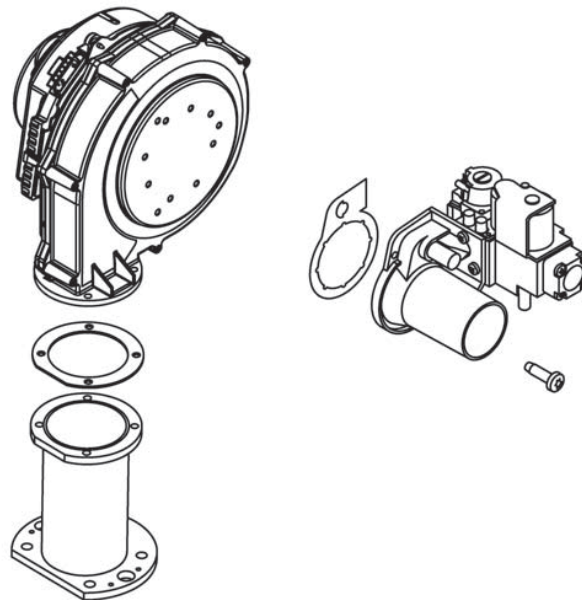

Service Procedure VI: Flame Sensor Testing and Replacement

Flame Sensor Testing Procedure

! WARNING

120 volt potential exposure. Use caution making voltage checks to avoid personal injury. Flame sensor may be too hot to handle, take necessary precautions.

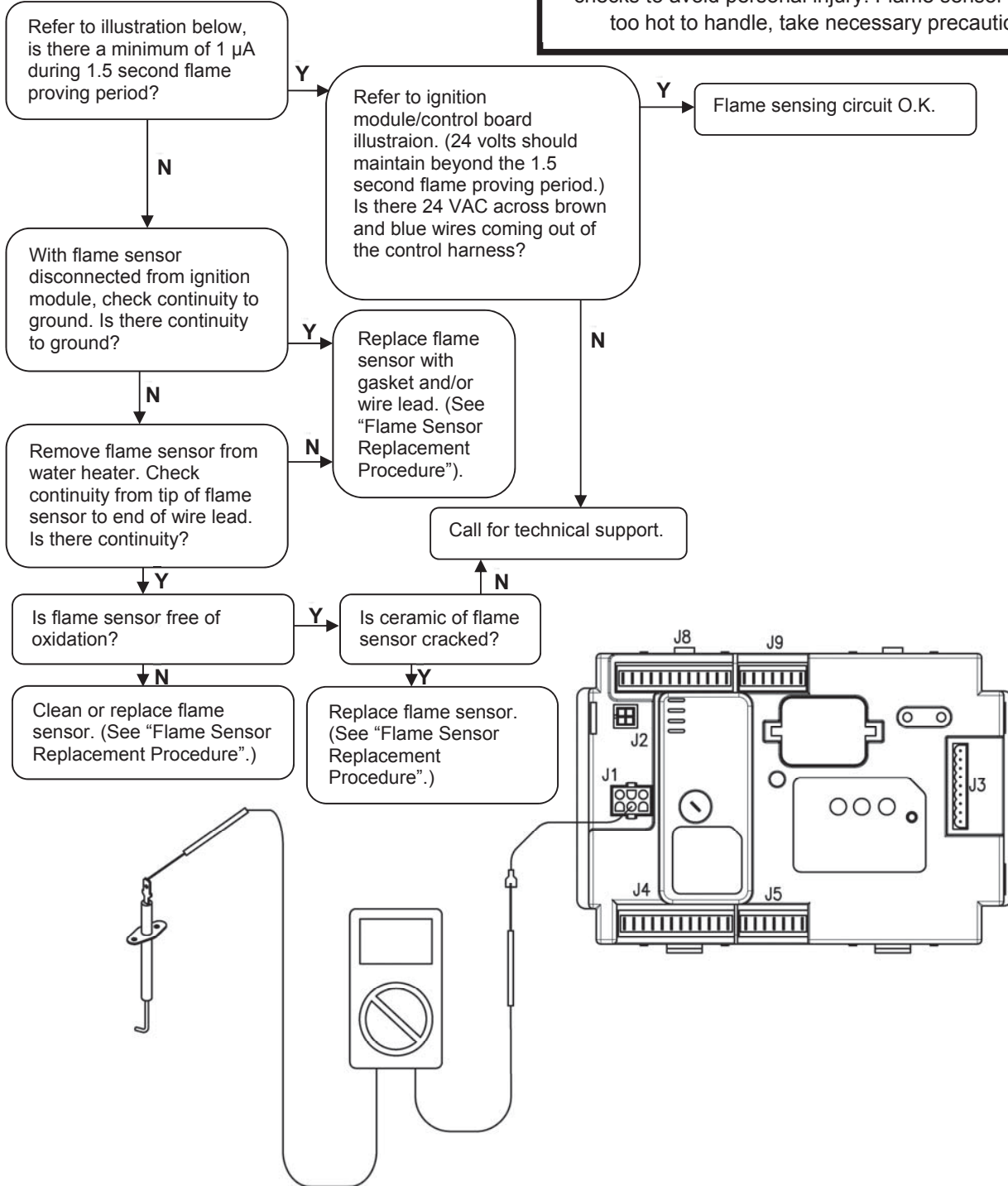

Service Procedure VI: Flame Sensor Testing and Replacement

Flame Sensor Replacement Procedure

- Step 1. Position main power switch to "OFF"
- Step 2. Disconnect (unplug) water heater from 120 volt power source.
- Step 3. Un-latch & remove surround cover from top of heater.
- Step 4. Disconnect wire lead from flame sensor.
- Step 5. Remove the 2 sensor mounting screws (magnetic tip, long reach Phillips screw driver) and remove flame sensor & gasket from transition base flange.
- Step 6. Remove any residual gasket material from transition base flange.
- Step 7. Install new flame sensor with new gasket provided using screws from step 6. Arrange flame sensor with hook towards burner.
- Step 8. Reconnect flame sensor wire.
- Step 9. Restore 120 volt power supply to water heater and confirm proper operation following the lighting instructions on the lighting instruction label or the lighting instructions located in the installation and operating instruction manual.
- Step 10. Replace surround cover on top of water heater.

 **WARNING**

120 volt potential exposure. Isolate the appliance and reconfirm power is disconnected using a multi-meter.

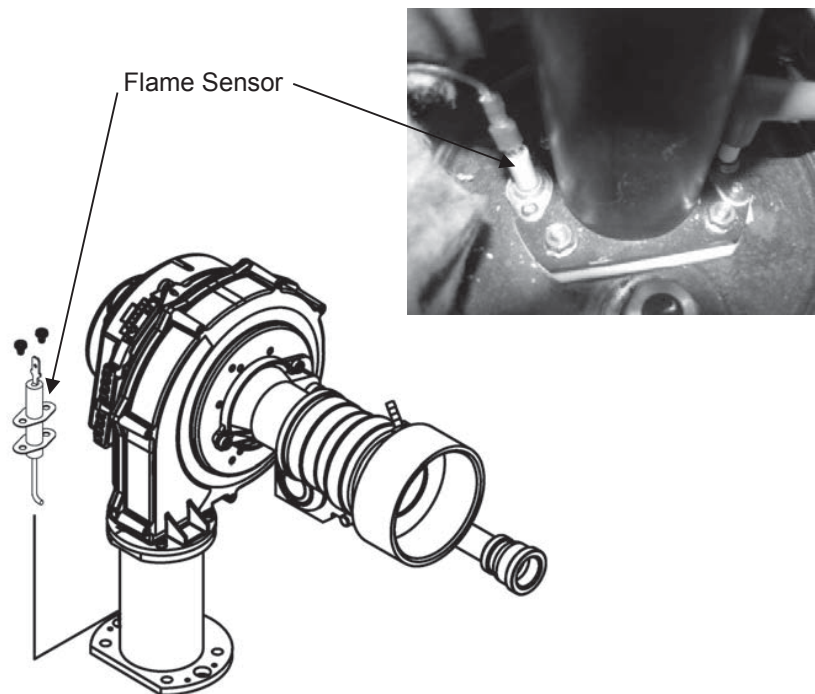

Service Procedure VII: Spark Rod Gap Adjustment and Replacement

Spark Rod Gap Inspection and Adjustment

- Step 1. Remove combustion system as described in "Combustion System Removal Procedure."
- Step 2. Measure spark gap between the spark rod and burner tube. Acceptable spark gap is from 3/16" to 1/4" (see photo below).
- Step 3. If spark gap is not between 3/16" to 1/4", the spark rod may be carefully bent by supporting the end near the ceramic insulator with pliers and bending the end near the burner tube with needle nose pliers (see photo below).
- Step 4. Re-measure and verify spark gap is between 3/16" to 1/4" after bending.
- Step 5. Verify the integrity of all gaskets and replace where required.
- Step 6. Reinstall the combustion system per "Combustion System Replacement Procedure" and check several ignitions to ensure the burner lights smoothly.

WARNING

Spark gap must be set from 3/16" to 1/4". Failure to set and verify proper spark gap may result in a delayed ignition resulting in damage to the water heater.

CAUTION

Use caution while performing these steps to prevent stressing or cracking the ceramic insulator.

Burner Tube Spark Rod

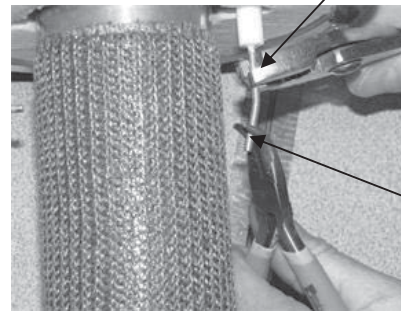
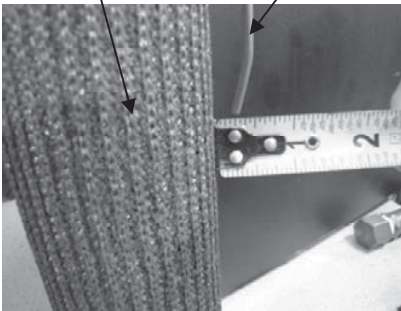

Hold spark rod near ceramic insulation.

Bend spark rod near burner tube.

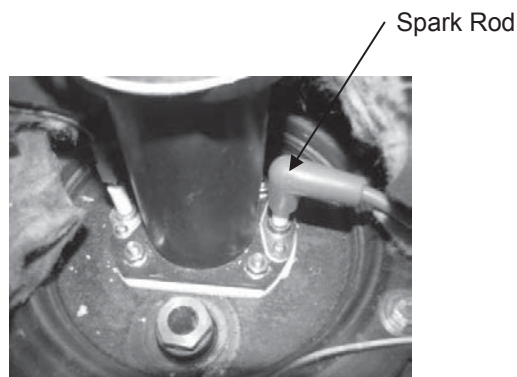

Service Procedure VII: Spark Rod Gap Adjustment and Replacement

Spark Rod Replacement Procedure

- Step 1. Position main power switch to "OFF"
- Step 2. Disconnect (unplug) water heater from 120 volt power source.
- Step 3. Un-latch & remove surround cover from top of heater.
- Step 4. Disconnect wire lead from spark rod.
- Step 5. Remove the 2 mounting screws (magnetic tip, long reach Phillips screw driver) and remove spark rod & gasket from transition base flange.
- Step 6. Remove any residual gasket material from transition base flange.
- Step 7. Install new spark rod with new gasket provided using screws from step 6. Arrange spark rod with hook towards burner (off-center mounting hole towards the front of the water heater).
- Step 8. Remove combustion system following "Combustion System Removal Procedure," and verify spark gap following "Spark Rod Gap Inspection and Adjustment." Reassemble combustion system following "Combustion System Replacement Procedure."
- Step 9. Restore 120 volt power supply to water heater and confirm proper operation following the lighting instructions on the lighting instruction label or the lighting instructions located in the installation and operating instruction manual.
- Step 10. Replace surround cover on top of water heater.

WARNING

120 volt potential exposure. Isolate the appliance and reconfirm power is disconnected using a multi-meter.

WARNING

If the spark rod is replaced for any reason, the combustion system **MUST** be removed and the spark gap to the burner measured and adjusted properly

WARNING

Spark gap must be set from 3/16" to 1/4". Failure to set and verify proper spark gap may result in a delayed ignition resulting in damage to the water heater

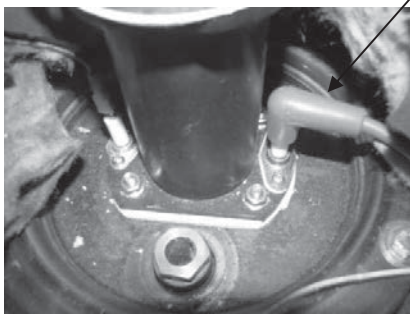

Spark Rod

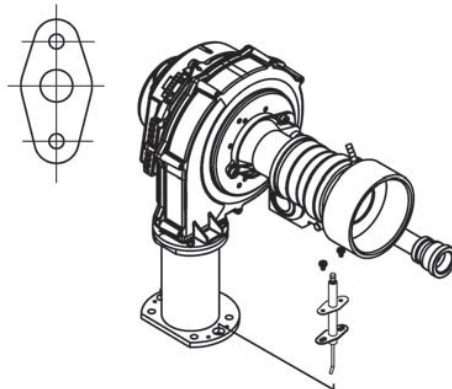

Service Procedure VIII: Ignition Module/Control Board Replacement

Control Board Replacement

- Step 1. Position main power switch to "OFF"
- Step 2. Disconnect (unplug) water heater from 120 volt power source.
- Step 3. Un-latch and remove top surround cover from top of water heater.
- Step 4. Locate control board.
- Step 5. Carefully disconnect all wire connections from control board.

Note: It may be necessary to identify wires for proper re-connection.

- Step 6. Depress the plastic tabs on the bottom side of the control board first.
- Step 7. Tilt the control panel and slide control hook tabs from slots in the control panel (see photo below).
- Step 8. Replace control board and all wire connections.
- Step 9. Restore 120 volt power supply to water heater and confirm proper operation following the lighting instructions on the lighting instruction label, or the lighting instruction located in the installation and operating instruction manual.
- Step 10. Replace surround cover on top of water heater.

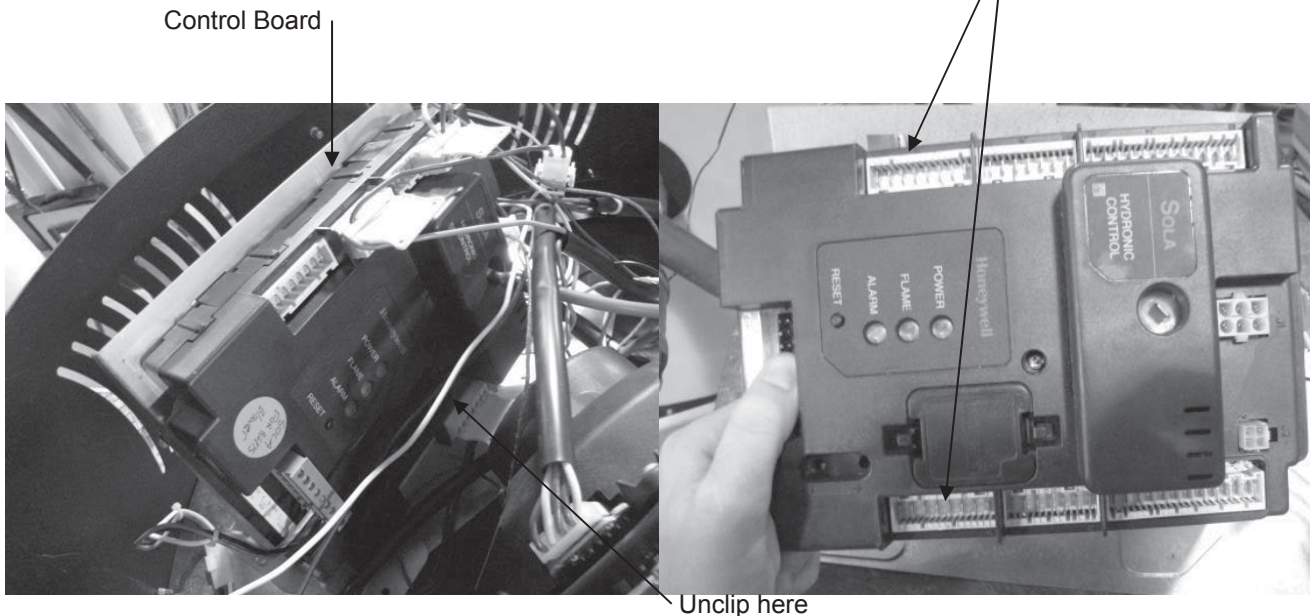

Service Procedure IX: Blocked Vent Switch Inspection and Replacement

Blocked Vent Switch Procedure

Step 1. First determine if the “Blocked Vent Switch” was installed correctly on the drafthood (see picture right).

Step 2. When Error Code 26 is present you first must determine if there is a blocked vent condition present. If so, clear the obstruction and reset the switch then continue with normal operation.

Step 3. If the switch is tripped and there is no obstruction in the venting there could have been an extended down draft that tripped the switch. The down draft could have been caused by damage vent termination. Contact your plumbing professional to correct this issue.

Step 4. When no blockage or downdraft issues are present check the continuity of the switch (see photo below). If there is no continuity present even when switch is reset the blocked vent switch assembly needs to be replaced.

Step 5. If blocked vent switch assembly is functioning correctly check to see if the wire harness has any signs of damage. Replace harness if any signs of damage exist.

Step 6. Restore water heater to use and confirm proper operation following the lighting instructions on the lighting instruction label or the lighting instruction located in the installation and operating instruction manual.

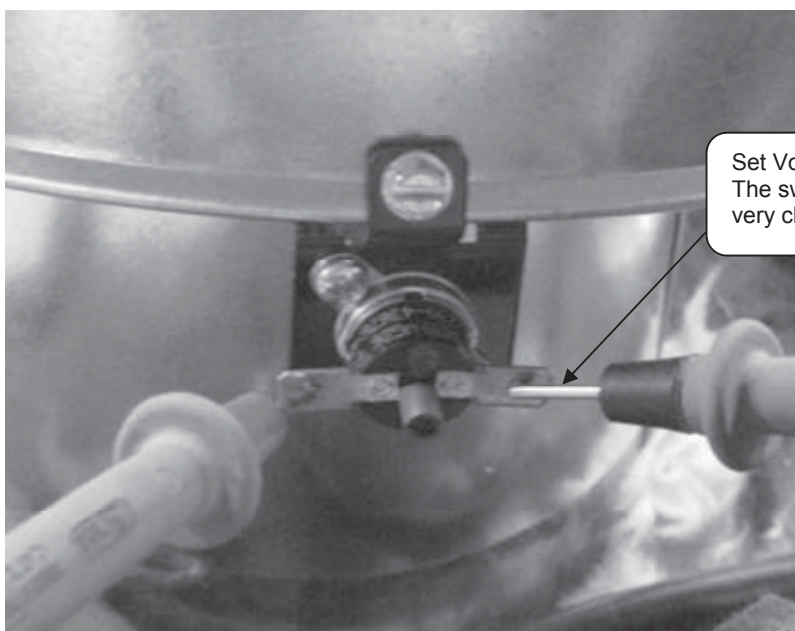
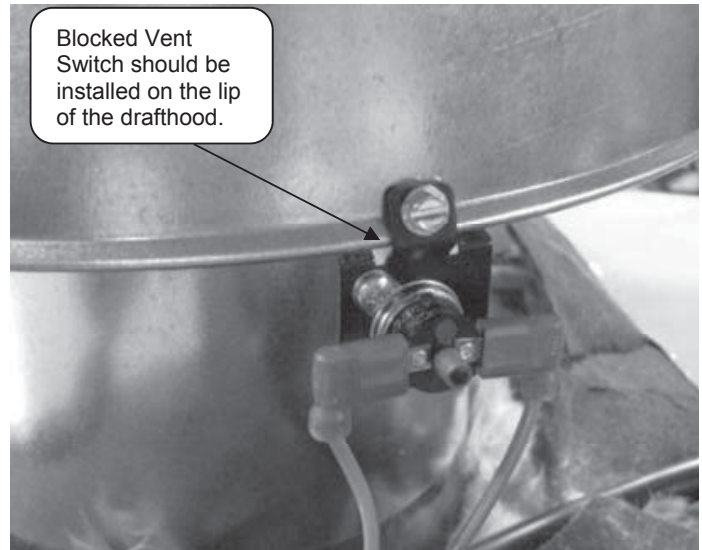

Service Procedure X: Anode Inspection and Replacement

Anode Replacement Procedure

- Step 1. Position main power switch to "OFF"
- Step 2. Disconnect (unplug) water heater from 120 volt power source.
- Step 3. Turn off water supply and drain water heater.
- Step 4. Locate (see photo below) and remove anode rods from heater (1-1/16 hex socket).
- Step 5. Visually inspect anode rod. Anode rod should show signs of depletion, this is normal. If the depletion is $\frac{1}{2}$ of the original diameter (approximately $\frac{3}{4}$ " diameter), replacement is recommended. If any of the steel core of the anode is exposed, replacement is recommended.
- Step 6. Upon completion of inspection or subsequent replacement, apply thread sealing tape or other thread compound to threads of anode and reinstall into heater. Restore water supply and check for and repair any leaks found.
- Step 7. Restore 120 volts to water heater and verify proper heater operation following the instructions on the lighting instruction label or the lighting instruction located in the installation and operating instruction manual.



Heater components and stored water may be HOT when performing the following steps in this procedure. Take necessary precaution to prevent personal injury.

Top of water heater.

Anodes located under plastic covers by inlet and outlet water connections.

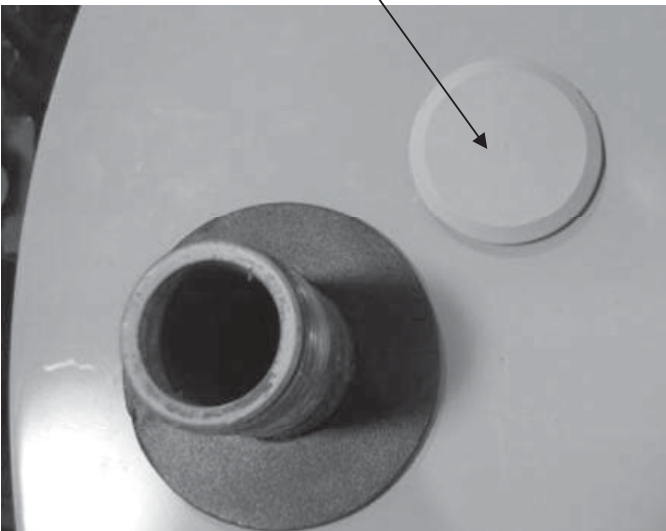

Cut access hole through insulation.

After removing insulation you will have access to the anodes.

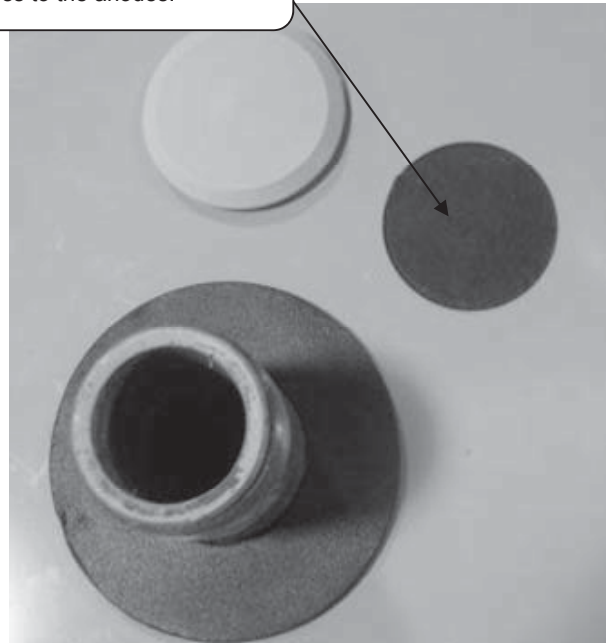

Service Procedure XI: Display Module Replacement

Display Module Replacement

- Step 1. Position main power switch to "OFF"
- Step 2. Disconnect (unplug) water heater from 120 volt power source.
- Step 3. Remove four screws that hold the display into the enclosure (shown on the right).
- Step 4. After removing the screw pull the display out of the enclosure.
- Step 5. Once the display is removed disconnect the two mating plugs.
- Step 6. Connect in new display and replace into the enclosure.
- Step 7. Use the four screws from step 3 and reinstall the display onto the enclosure.
- Step 8. Restore 120 volt power supply to water heater and confirm proper operation following the lighting instructions on the lighting instruction label or the lighting instruction located in the installation and operating instruction manual.

 **WARNING**

120 volt potential exposure. Isolate the appliance and reconfirm power is disconnected using a multi-meter.

Display and Enclosure



Disconnect

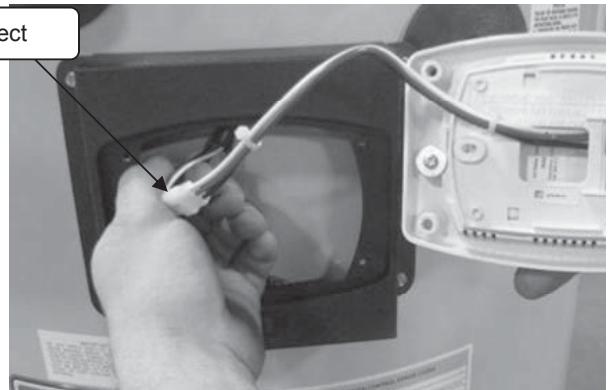

Service Procedure XII: Transformer Replacement

Transformer Replacement Procedure

- Step 1. Position main power switch to "OFF."
- Step 2. Disconnect (Unplug) water heater from 120 Volt power source.
- Step 3. Un-latch & remove surround cover from top of water heater.
- Step 4. Disconnect primary leads (black & white) and secondary leads (blue & yellow) from the transformer. (connections are different sizes to prevent interchanging)
- Step 5. Remove the 2 nuts (7/16 nut driver) holding the transformer in place and remove transformer from control panel. (see photo below)
- Step 6. Install new transformer and secure in place with screws from step 6.
- Step 7. Reconnect primary and secondary wires to transformer (leads are different sizes to prevent interchanging).
- Step 8. Restore 120 volt power supply to water heater and confirm proper operation following the lighting instructions on the lighting instruction label or the lighting instruction located in the installation and operating instruction manual.
- Step 9. Replace surround cover on top of water heater.

 **WARNING**

120 volt potential exposure. Isolate the appliance and reconfirm power is disconnected using a multi-meter.

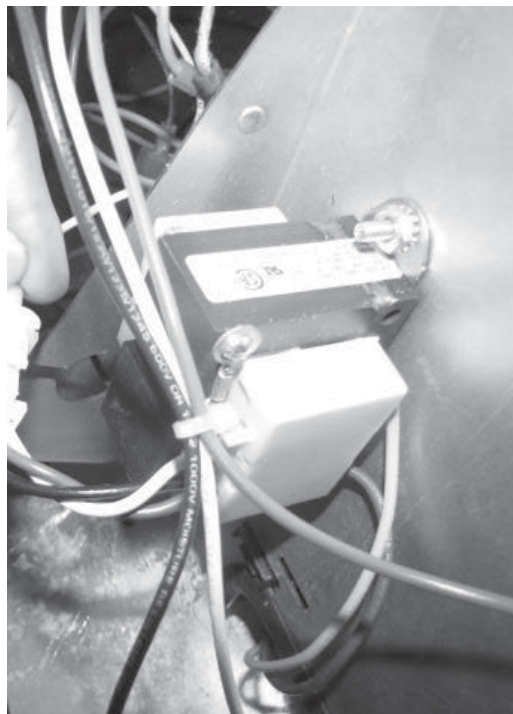

Water Heater Installation Check list

Product Handling - Carefully uncrate the heater. Move in place with a hand truck (Do not use the venting pipes for handles).

Electrical Requirements - Make sure there is 120 volts line voltage. Line voltage must be properly polarized. Adequate ground supplied to the heater.

Venting Requirements - All venting must stay within the required lengths and diameter (see table below). Proper support of the venting pipe is a MUST (every 5ft vertical and 3ft horizontal). Termination must be located to prevent re-circulation of flue gases.

Gas Requirements - Gas piping sized adequately, $\frac{3}{4}$ " . Install a properly sized regulator (if unknown, assure an adequate volume of gas is available). 7" W.C. is required when the unit is running. Gas pressure must stay below 14" W.C. static pressure. Pressure drops between static pressure and operating flow should be less than 3" W.C.

Service/Mechanical Room - Provide adequate space for servicing heater. Leave enough overhead room to remove the anode rods for servicing (18" min.).

Vent Tables (Intake Only)

<i>Model Number</i>	<i>Max Intake Vent Length (feet) 3"</i>	<i>Max Intake Vent Length (feet) 4"</i>
UCG100H399	25	50
UCG80H399	25	50

WARNING! The UCG(80,100)H399 model is not approved for 2 inch diameter intake vent pipe. Venting with 2 inch pipe may result in damage to the water heater or cause an unsafe condition. **DO NOT** use 2 inch Vent or Air Intake Pipe!

Determining required intake vent length

1. Determine the total length of straight vent pipe (in feet) required for the intake.
2. Add 5 feet of venting for every 90° elbow.
3. Add 2 ½ feet of venting for every 45° elbow.
4. **Total intake vent length cannot exceed "Max Intake Vent Length" on the venting table shown above.**

Example of Total Intake Vent Length for UCG100H399 installation:

A 3" venting system has a total of two 90-degree elbows and a total straight pipe length of 10 feet.

Equivalent vent length for elbows: 2 x 5 feet = 10 feet.

Total equivalent intake vent distance = 10 feet + 10 feet = 20 feet total equivalent vent length. This is below the maximum allowed distance of 25 feet for this model using 3" vent.

The "metal/atmospheric" exhaust system of this unit must follow the National Fuel Gas code.

Water Heater Service Report

Date _____

Service Provider _____

Phone Number _____

Model Number _____

Serial Number _____

Intake Venting (PVC, CPVC):

Intake Vent size 3", 4" _____

Intake 45° Elbows (qty) _____

Length of Straight Pipe
(Intake) _____

Intake 90° Elbows (qty) _____

Exhaust Vent Size 6",7",8" _____

Gas Line:

Size & Material _____

Distance from Meter to Water
Heater _____

Gas Pressure:

Static _____

Running Inlet _____

Manifold _____

Venturi:

Setting from Bottom in Turns

Electrical:

Line Voltage _____

Low Voltage _____

Polarity _____

Flame Sense (μ A) _____

Spark Gap _____

Error Codes on Control Display _____

Combustion:

CO₂ _____

CO _____

Installation Site Name & Address:

Installation Site Contact Name & Phone Number

Parts List

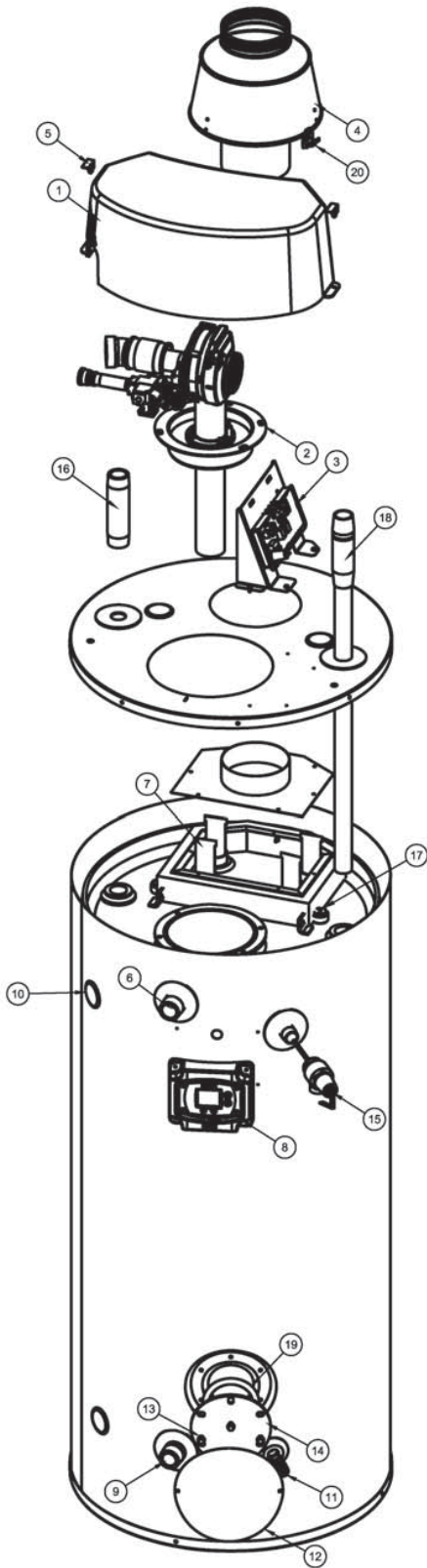

Water Heater Full Assembly

1	Surround Assembly
2	Combustion Assembly (specify model)
3	Ignition Control Assembly
4	Draft Hood (specify model)
5	Swell Latch
6	Front Hot Water Outlet
7	Baffle 2" Flue (Specify Model)
8	Control Display
9	Front Cold Water Inlet
10	Plastic Hole Closure
11	No Handle Brass Drain Valve
12	Cleanout Access Cover
13	Screw 5/16-18 x 3/4" HH Grade
14	Cleanout Cover
15	T & P (specify model)
16	Hot Water Outlet Plastisert Nipple
17	Anode
18	Cold Water Inlet (Hydrojet) Assembly
19	Cleanout Gasket
20	Blocked Vent Switch

Customer must specify complete model number and serial number when ordering service parts.

Parts List

2 Combustion Assembly

1	Combustion Ass'y (Specify model)	13	Sesnor – Flame Sense
2	Blower/Gas Valve Assembly (specify model)	14	Igniter – Direct Spark
3	Burner Assembly (specify model)	15	Blower/Burner Mounting Plate
4	Blower (specify model)	16	Gasket Burner (specify model)
5	Gasket & Screw	17	Burner (specify model)
6	Transistion Tube	18	Burner Mount Assembly
7	Gasket Blower Transition	19	Sight Glass Assembly
8	Gasket Transition Tube	20	Gasket Sight Glass
9	1/4 – 20 Nut	21	Reducer 3/4 x 1/2 NPT
10	Screw 8-32 x 1/4" RHCR	22	Nipple 1/2 NPT x 3"
11	Gasket Flame Sense	23	Gas Valve
12	Gasket Igniter	24	Venturi

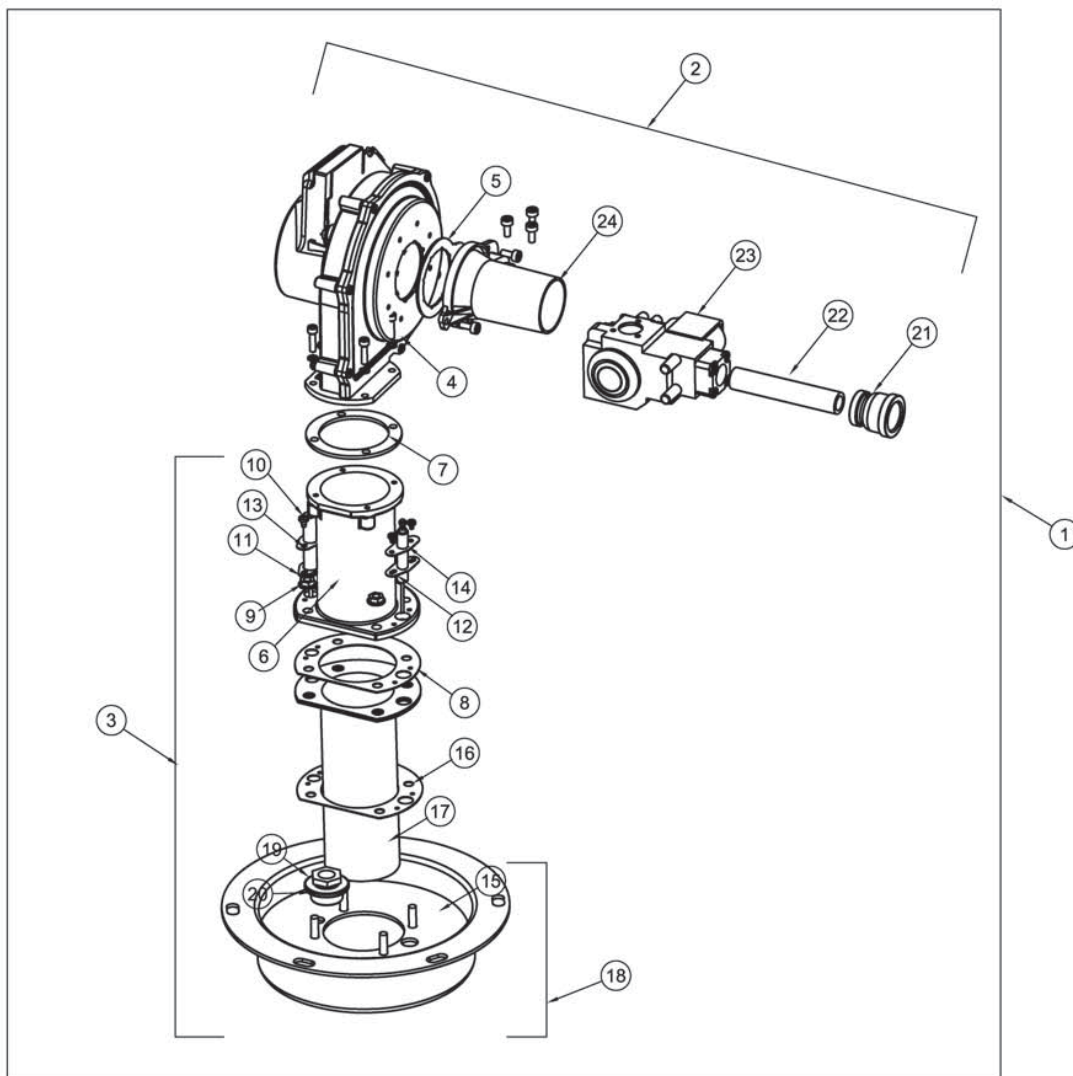

Customer must specify complete model number and serial number when ordering service parts.

Parts List

3 Ignition Control Assembly			
1	Control Panel	9	Hex Nut
2	Control	10	Ground Wire
3	Transformer	11	Power Cord Harness
4	Display Surround	12	Controller Harness
5	Screw	13	High Voltage Spark Cable
6	Switch Main Power	14	Gas Valve Harness
7	Control Display	15	Blower Modulation Harness
8	Weld Stud	16	Flame Sense Harness

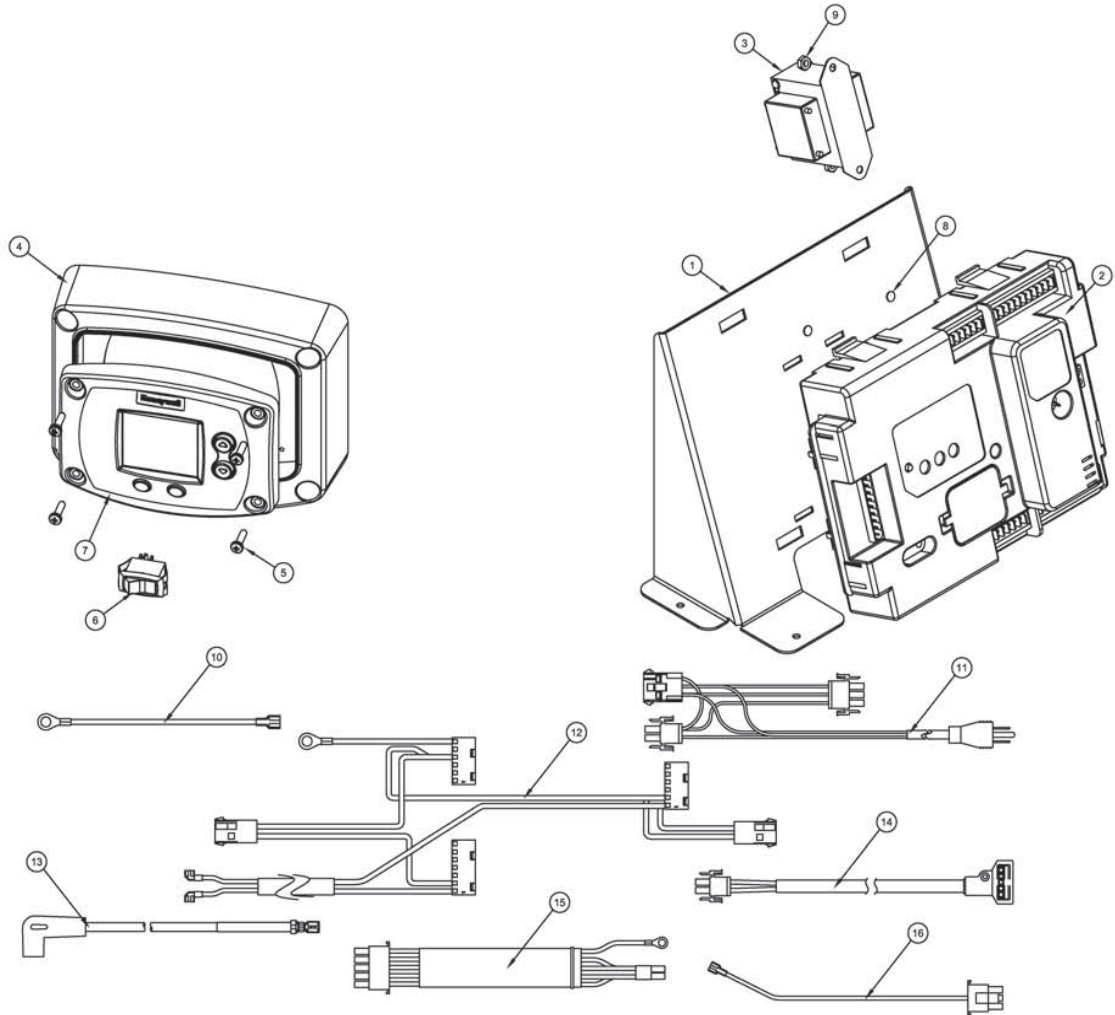

Customer must specify complete model number and serial number when ordering service parts.

Manufactured under one or more of the following U.S. Patents: 5,277,171; 5,341,770; 5,372,185; 5,485,879; 5,574,822; 5,596,952; 5,660,165; 5,682,666; 5,761,379; 5,943,984; 5,954,492; 5,988,117; 6,056,542; 6,142,216; 6,442,178; 6,684,821; 6,935,280; 7,063,132; 7,063,133; 7,007,748; 7,270,087; 7,334,419; 7,337,517; 7,409,925; 7,458,341; 7,559,293; 7,621,238; 7,634,976; 7,650,859; 7,665,210; 7,665,211; 7,699,026; 7,866,168; 7,900,589; 7,971,560; 7,992,526 8,082,888; 8,146,772; Other U.S. and Foreign patent applications pending. Current Canadian Patents: 2,092,105; 2,107,012; 2,108,186; 2,112,515; 2,143,031; 2,239,007; 2,262,174; 2,314,845; 2,409,271; 2,476,685; 2,504,824; 2,548,958

Glossary of Terms

AC	Alternating Current
BTU/H	British Thermal Units
CO	Carbon Monoxide
CO ₂	Carbon Dioxide
DC	Direct Current
DSI	Direct Spark Ignition
ECO	Energy Cut Off
GFI	Ground fault interrupt
GPM	Gallons per Minute
Hz	Hertz
LED	Light Emitting Diode
NO _x	Oxides of Nitrogen
NPT	National Pipe Thread
PSI	Pounds per Square Inch
RPM	Revolutions per Minute
VA	Volt Amps
VAC	Volts Alternating Current
W.C.	Inches of Water Column
°C	Degrees Centigrade
°F	Degrees Fahrenheit
μA	Micro Amp



United States

Sales 800-523-2931

Technical Support 800-334-3393

Email techserv@bradfordwhite.com

Warranty 800-531-2111

Email warranty@bradfordwhite.com

Service Parts 800-538-2020

Email parts@bradfordwhite.com

Canada

Sales & Technical Support 866-690-0961 905-03-0600

Fax 905-636-0666

Warranty bwccwarranty@bradfordwhite.com

Technical Support bwccotech@bradfordwhite.com

Service Parts orders@bradfordwhitecanada.com

Orders ca.orders@bradfordwhite.com

For U.S. and Canada field service,
contact your professional installer or
local Bradford White sales representative.

International

General Contact international@bradfordwhite.com