

Model 500XL3

Pressure Reducing Valve

(2 1/2" & 3")

*This product contains a weighted average lead content less than 0.25% for wetted surfaces.

*Meets the requirements of NSF/ANSI/CAN 61 & 372

LEAD-FREE*



□ Installation □ Testing □ Maintenance Instructions

INSTALLATION INSTRUCTIONS

Before installing reducing valve, flush out line to remove loose dirt and scale which might damage seal ring and seat. Install valve in line with arrow on valve body pointing in direction of flow.

All valves will be furnished with stock settings to reduce to 50 psi. To readjust reduced pressure, loosen outer locknut and turn adjustment bolt clockwise (into bell housing) to raise reduced pressure, or counterclockwise (out of bell housing) to lower reduced pressure.

CAUTION: Anytime a reducing valve is adjusted, a pressure gauge must be used downstream to verify correct pressure setting. Do not bottom out adjustment bolt on bell housing. Valve may be installed in any position.

NOTICE: Annual inspection and maintenance is required of all plumbing system components. To ensure proper performance and maximum life, this product must be subject to regular inspection, testing and cleaning. The valve shall be installed in an accessible location. Also, it is recommended that a suitable strainer be installed upstream of the valve.

Due to highly efficient flow performance, it is not recommended to use a 1" or 1-1/4" 500XL3 as a standalone low flow bypass valve in parallel. Instead, it is recommended that a 2-1/2" or 3" 500XL3FBP be paired with a 1-500XL3BPK and used as a low flow/high flow parallel PRV configuration. This configuration can be used in high flow, high pressure drop applications that also will see low flow usage. Unlike the standard 500XL3, this 1-500XL3BPK can be used as a bypass valve due to a restricting tailpiece included in this bypass configuration.

Regulators in series: Where the desired pressure reduction is more than a 3 to 1 ratio (i.e. 150psi to 50psi), multiple regulators in series should be installed. The first regulator should be set to drop the pressure halfway to the desired outlet pressure. High range valves are available with 75-125psi outlet pressure range.

Troubleshooting

Pipe lines in a water supply system must be of sufficient carrying capacity to maintain adequate pressure at the most remote or highest fixture. Under the maximum probable fixture use, minimum adequate pressure is generally 8 to 15 psi but may be more, depending on the equipment being supplied. Relatively high service pressures which can create high water velocities in pipe lines would allow use of smaller pipes to satisfy fixture use. However, high velocity tends to cause whistling and humming. Reduction of pressure by the use of a pressure reducing valve, in an attempt to eliminate such a condition, may reduce pipe line capacities below that which is adequate for maximum probable use. When high service pressures are in effect, either continuously or periodically, the application of a pressure reducing valve will be successful only when the installed pipe line is of adequate size to satisfy the system demand at the lower pressure. When actual water demands are unknown, the valve size should be no less than the existing pipe size.

PROBLEM

1. **Pressure creeps or builds up in system above the setting of pressure reducing valve.**

POSSIBLE CAUSE OR CAUSES

- A. Thermal expansion of water as it is being heated.
- B. Foreign matter on seating face of seal ring.
- C. Cut, worn or chipped seal ring.
- D. Cut or worn stem o-ring or worn o-ring groove.

SOLUTION

- a. This is a natural occurrence. It may happen each time that the heater runs. A pressure relief valve or expansion tank must be installed. This will not prevent pressure rise but should limit it to a safe level.
- b. Flush the reducing valve by opening one or two fixture outlets wide open. If this does not correct the problem, wipe off the exposed surface of the seal ring with a rag.
- c. Install a new cartridge assembly.
- d. Install a new cartridge assembly.

2. **Pressure and fixture flow is unsteady.**

- A. Low water supply pressure in mains caused possibly by high area demand during certain periods of the day.
- B. Heavy periodic demands by appliances in the building.

SOLUTION

- a. This is a water department problem. It is due to the mains being inadequate for the demands made on them.
- b. Building service lines may at times be inadequate for the load. Size of some pipelines may need to be increased, or pressure setting of reducing valve may be too low. Try increasing pressure before changing pipelines.

3. **Small, inadequate flow from fixtures.**

- A. Pipelines to fixtures may be too small or building main supply may be inadequate for normal fixture demand.
- B. Heavy periodic demands by appliances in the building.
- C. An upstream screen in a y-strainer may be clogged.

⚠ **WARNING:** Cancer and Reproductive Harm - www.P65Warnings.ca.gov
⚠ **ADVERTENCIA:** Cáncer y daño reproductivo - www.P65Warnings.ca.gov
⚠ **AVERTISSEMENT:** Cancer et néfastes sur la reproduction - www.P65Warnings.ca.gov



- SOLUTION
- It may be necessary to increase pipe sizes only in some sections of the system leading to the offending appliances or fixtures. Increasing the building service mains might be necessary if small supply is general at all fixtures.
 - Raise pressure gradually by readjusting valve until this point is determined.
 - Clean strainer.

4. Valve appears to be noisy; hums, whistles or chatters.

- Hum or whistle is usually caused by a high velocity of flow in pipelines causing vibration.
- Chatter usually originates with worn seal ring.
- Pressure reduction ratio from inlet to outlet is too high, above 3:1.

- SOLUTION
- Pipelines could be small or too light. Reducing valves could be too small. Pipes and valves being small would accentuate this condition.
 - Inspect seal ring. If a deep channel appears on seal ring face, replace the cartridge assembly.
 - Adjust downstream pressure in small increments until the noise stops. Alternatively, install two valves in series for large pressure reduction, or install a 3/4" 20XL bypass valve to handle low flows and high inlet to outlet pressure ratios.

Maintenance Instructions

REPAIR KIT INSTRUCTIONS

HOW TO MAKE REPAIRS:

(Shut off service before starting disassembly)

- Open faucet on dwelling to remove line pressure.
- Note the distance that adjustment bolt protrudes from bell housing. Loosen locknut on adjustment bolt, then turn adjustment bolt out of bell housing to remove spring tension.
- Unscrew all bell bolts counterclockwise and remove spring, and spring disc.
- Remove cartridge from body by inserting a flat head screwdriver under the diaphragm disc and lifting upwards.
- Ensure upper and lower cartridge o-rings are removed from the body.
- Guide pins do not need to be removed unless the guide pin o-rings are leaking.
- While disassembled, open inlet of water service to flush out valve body and service line of debris. Clean and inspect the two grooves where the cartridge o-rings sit.

TO REASSEMBLE:

- Replace old cartridge assembly with new cartridge assembly. Ensure top and lower o-rings are seated on the cartridge. Use supplied NSF approved silicone grease to lubricate the o-rings.
- Align the two holes in the bottom of the plunger with the guide pins in the bottom of the body. Push the cartridge into bore in body making sure o-rings seal tight against both the cartridge and the body.
- Replace spring, spring disc and bell. Insert and tighten all bell bolts onto body by threading clockwise until hand tight. See Table 1 for torque specifications.
- Turn adjustment bolt into bell housing to old setting.
- Enter dwelling and turn on several faucets.
- Turn on water service. Let water run for several seconds then turn off faucets in dwelling.
- Adjust regulator to desired pressure by turning adjustment bolt clockwise (into bell housing) to raise pressure or counterclockwise (out of bell housing) to lower pressure. A pressure gauge should be used to verify proper setting.
NOTE: When reducing pressure open a downstream faucet to relieve pressure.
- Tighten locknut when desired pressure is achieved.

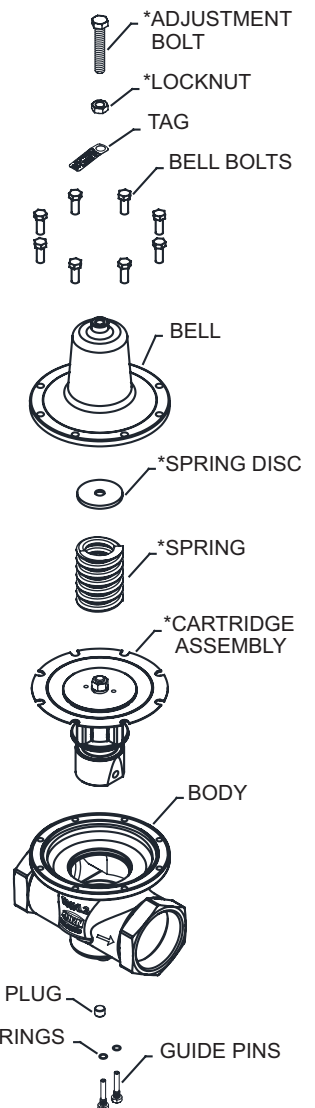

**TABLE 1.
VALVE TORQUE SETTINGS**

| VALVE SIZE (in) | BELL BOLTS (ft - lbs) |
|-----------------|-----------------------|
| 2-1/2" | 30 |
| 3" | 30 |

*** INDICATES PARTS SUPPLIED IN REPAIR KITS**

WARRANTY: ZURN WILKINS Valves are guaranteed against defects of material or workmanship when used for the services recommended. If in any recommended service, a defect develops due to material or workmanship, and the device is returned, freight prepaid, to ZURN WILKINS within 12 months from date of purchase, it will be repaired or replaced free of charge. ZURN WILKINS' liability shall be limited to our agreement to repair or replace the valve only.