

RECTORSEAL

A CSW Industrials Company

INSTALLATION INSTRUCTIONS

RSH™50 VRM KIT

120/240 single Phase, 60 Amp Double Pole Capacity Relays (handles loads 15 to 60 Amps)

PRODUCT CODE **96421**



Installation Instructions

1. Device must be installed in an enclosure suitable for the application and environment for which it is being used. Connected load shall not exceed 60 amps.
2. Confirm power is OFF prior to performing the installation.
3. Use the appropriate wire size and type based on the connected load and torque to the specified ratings.
4. Connect input and output connections, replace finger guard covers and then restore power.
5. Confirm power LED is illuminated and proceed to programming functions.
6. Optional mounting feet included to secure enclosure to wall or structure.

Programming Instructions

Start Up: At power up, load will remain disconnected for 4 minutes. This delay is not adjustable. To view event logs, press UP button. **E1** - Over voltage events, **E2** - Under voltage events, **E3** - Outages

To enter program mode - Press and hold MODE button for 2 seconds

Mode U0 - Utility over-voltage set point. Use the UP & DOWN buttons to set the desired over-voltage cut off point between 85-300 vac Press MODE button to advance to next setting.

Mode UL - Utility under-voltage set point. Use the UP & DOWN buttons to set the desired under-voltage cut off point between 85-300 vac. Press MODE button to advance to next setting.

Mode S0.5 - Over/under delay. Use the UP & DOWN buttons to adjust the delay time between .5 and 60 seconds before the load is disconnected when an under or over voltage condition is present. Press MODE button to advance to next setting.

Mode SP - Load restore delay. Use the UP & DOWN buttons to adjust the delay time between 1 and 600 seconds before the load is restored after normal power levels have returned.

Mode EC - Event-log clear. To retain stored events, set to **1**. To clear ALL stored events, set to **0**. Press and hold the MODE button for 2 seconds to save changes and exit.

Diagram

Main Terminals
CU7 Copper Conductors Only
10-14 AWG 35 IN. LBS.
8 AWG 40 IN. LBS.
4-6 AWG 45 IN. LBS.
2-3 AWG 50 IN. LBS

Auxiliary Terminals
CU7 Copper Conductors Only
12-16 AWG 20 IN. LBS.

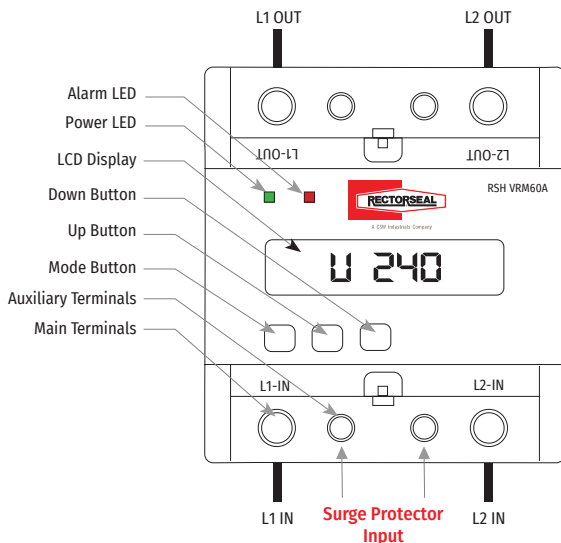

Para instrucciones en español visite www.rectorseal.com

Technical Support Call 1-866-280-8810

All surge protection devices require a good ground connection for effective operation



120/240 single Phase, 60 Amp Double Pole Capacity Relays (handles loads 15 to 60 Amps)

WARRANTY INFORMATION & SAFETY NOTICE

Coverage for the RSH-VRM Voltage Range Monitoring Device

2-Year Limited Product Warranty

PSP Products, Inc. ("Manufacturer") warrants this product to be free from defects in material or workmanship for a period of two (2) years following the date of purchase.

The warranty does not cover defects or malfunction caused by misuse, abuse or improper maintenance, failure to follow operating instructions, improper installation or application, acts of God, or normal wear and tear. Also, the warranty will not apply to damage caused by unauthorized alteration, modification, or repair of the product.

Manufacturer shall not be liable for any costs of removal or installation. Manufacturer's sole and exclusive obligation under this warranty shall be limited to repair or replacement of the defective item.

This limited warranty gives you specific legal rights, and you also may have other rights that vary from state to state or country to country. The laws of certain jurisdictions do not allow limitations on implied warranties or the exclusion or limitation of certain damages, so some or all the above disclaimers, exclusions or limitations may not apply or apply fully to you.

Coverage for the RSH-50 Surge Protective Device (SPD) for Single-Phase System

Lifetime Product Warranty

PSP Products, Inc. ("Manufacturer") will, at its sole discretion, repair or replace any RSH-50 Surge Protection Device (SPD) that is defective or is damaged by an electrical surge (including those caused by lightning) for the lifetime of the product from the date of installation by the original owner or owner of record of the premises (User) at no cost to the User.

Connected Equipment Warranty

Manufacturer will, at its sole discretion, repair or replace heating, ventilation and air conditioning equipment that is damaged as a result of SPD failure during a surge event. Coverage is applicable only if the SPD (1) was fully functional immediately prior to the claim event; (2) was properly installed per the installation instructions; and (3) sustained surge damage as a result of the claim event.

Damage claims must be made within 14 days of the occurrence and the SPD returned to Manufacturer within 30 days of the occurrence with the original purchase receipts of the SPD. Returned SPDs require an RMA (Return Materials Authorization) number and a completed Warranty Claim Form (contact Warranty Assistance for details), and the SPD must be determined to have failed based on Manufacturer's test procedures.

This coverage is secondary to any applicable warranties, service contracts and all other insurance. If the claim is found to be valid, Manufacturer will pay up to the deductible amount of the homeowner's insurance or the cost of the damage, whichever is less, subject to a \$5000.00 limit per occurrence. All the above items must be met in order to have a valid claim.

The above coverage applies to the User only and is the exclusive remedy under this warranty, whether based on contract, tort, including negligence, or otherwise. Manufacturer reserves the right to audit the damages, site and/or cost of repairs and may require a notarized proof of loss. This warranty does not cover damage associated with sustained over voltages, vandalism, theft, normal wear and tear, obsolescence, abuse, unauthorized modification or alteration, misuse, improper installation or catastrophic events including direct lightning hit.

Except as expressly provided by this warranty, Manufacturer disclaims liability for any incidental, indirect, special or consequential damages arising out of the sale or use of SPDs (including without limitation: lost business profits, loss of data and all freight, mileage, travel time and insurance charges associated with warranty coverage claims). Some states do not allow the exclusion or limitation of incidental or consequential damages, so the above limitation or exclusion may not apply to you. This warranty gives you specific legal rights and you may have other rights which vary from state to state. *This warranty is valid in the United States and Canada only.*

Caution: Effective surge suppression requires correct wiring and all SPDs must be properly grounded for this warranty to be honored.

For Warranty Assistance call 866-280-8810 • PO Box 4108, Manassas, VA 20110



Voltage or current hazard, follow these instructions or it could result in serious bodily injury or death.

Most electric product-related incidents are caused by failure to observe basic safety rules or precautions. Rectorseal cannot anticipate every possible circumstance that might involve a potential hazard.

Requirement

Installation MUST be completed by a qualified licensed tradesman in the field of electrical installation. This would include a thorough understanding of the requirements of NFPA 70: National Electrical Code® and all local codes.

Installation Process

The Installation must conform to these instructions and the local code authority having jurisdiction and the requirements of the power company. In the absence of code requirements follow NFPA 70 (latest edition) National Electric Code.

The Code which may be ordered from: National Fire Protection Association, 1 Batterymarch Park, Quincy, MA 02269.

