

#18, 3 COND. SJT0W CORD 105°C +3.000
 TO EXTEND BEYOND MOTOR 15.000 -.000
 (BLACK, WHITE & GREEN)

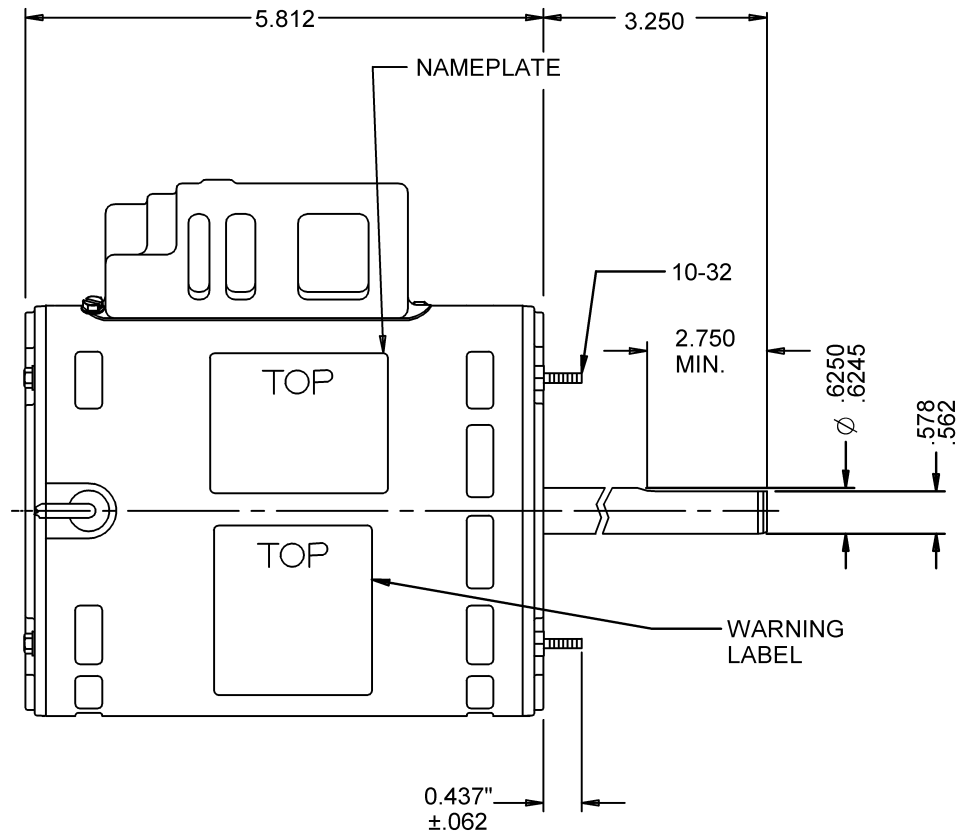
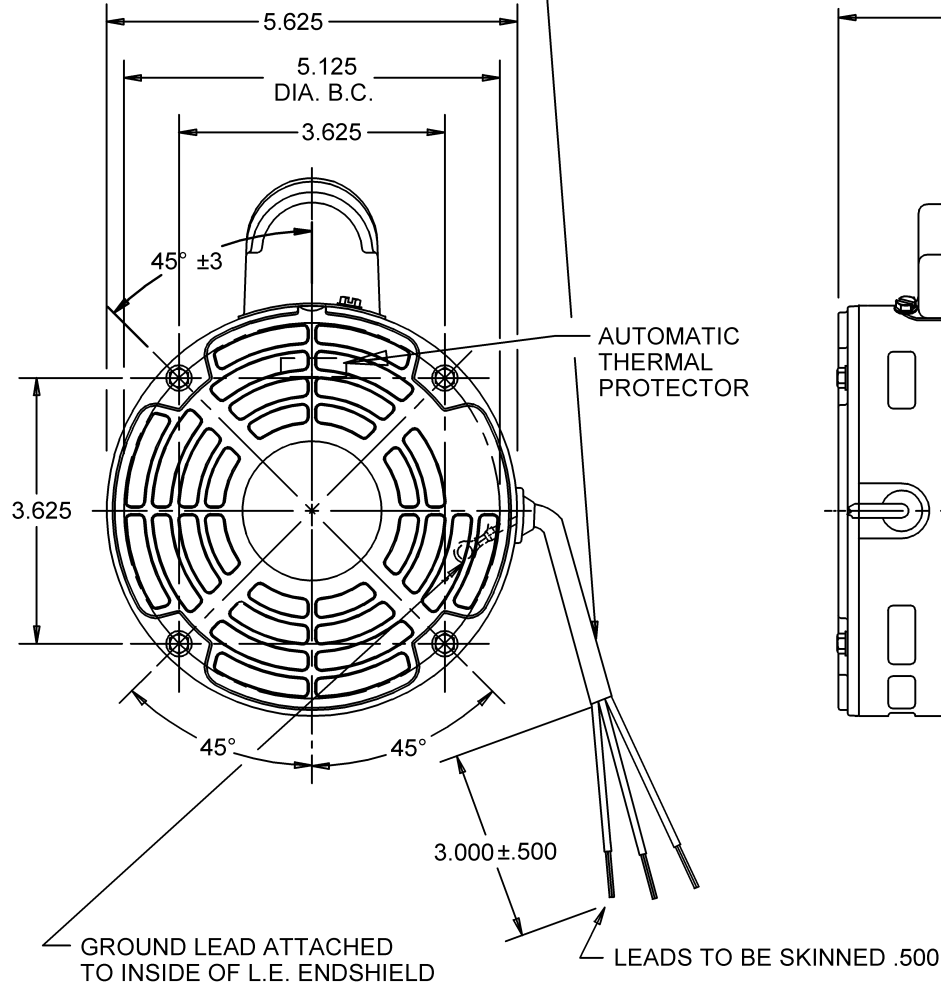

CONNECTIONS
 HIGH - BLACK
 COMMON - WHITE
 GROUND - GREEN

NIDEC MOTOR CORPORATION 15-Nov-12

MODEL	REF	CUSTOMER	HP	VOLTS	AMPS	HZ	RPM	ROTATION	CUSTOMER PN
K55HXEZW-7591		STANDARD	1/3	115	4.4	60	1100	CW LEAD END	4746

SHEET NUMBER	REV	REVISION RECORD FOR: C6402-02	
1 OF 1	G	UPDATED ENGINEER APPROVED TO B.GAITAN	
REVISION DATE			
15-NOV-12			

INFORMATION DISCLOSED ON THIS DOCUMENT IS CONSIDERED PROPRIETARY AND SHALL NOT BE REPRODUCED OR DISCLOSED WITHOUT WRITTEN CONSENT OF NIDEC MOTOR CORPORATION

NIDEC MOTOR CORPORATION

ISSUED BY	REVIEWED BY	ENGINEER APPROVED	REV
R. MORALES	M. LARGENT	B. GAITAN	G

TITLE		CODE	ITEM NO.	SIZE
ASSEMBLED VIEW		V01	753973	A