

EFFECTIVE:
16-APR-19

SUPERSEDES:
22-JAN-19

DIMENSION PRINT
WORLD MOTOR HOSTILE DUTY WITH CAST IRON OUTLET BOX
FRAME: 143T, 145T
BASIC TYPE: CT

PRINT:
08-1055-01

SHEET:
1 OF 1

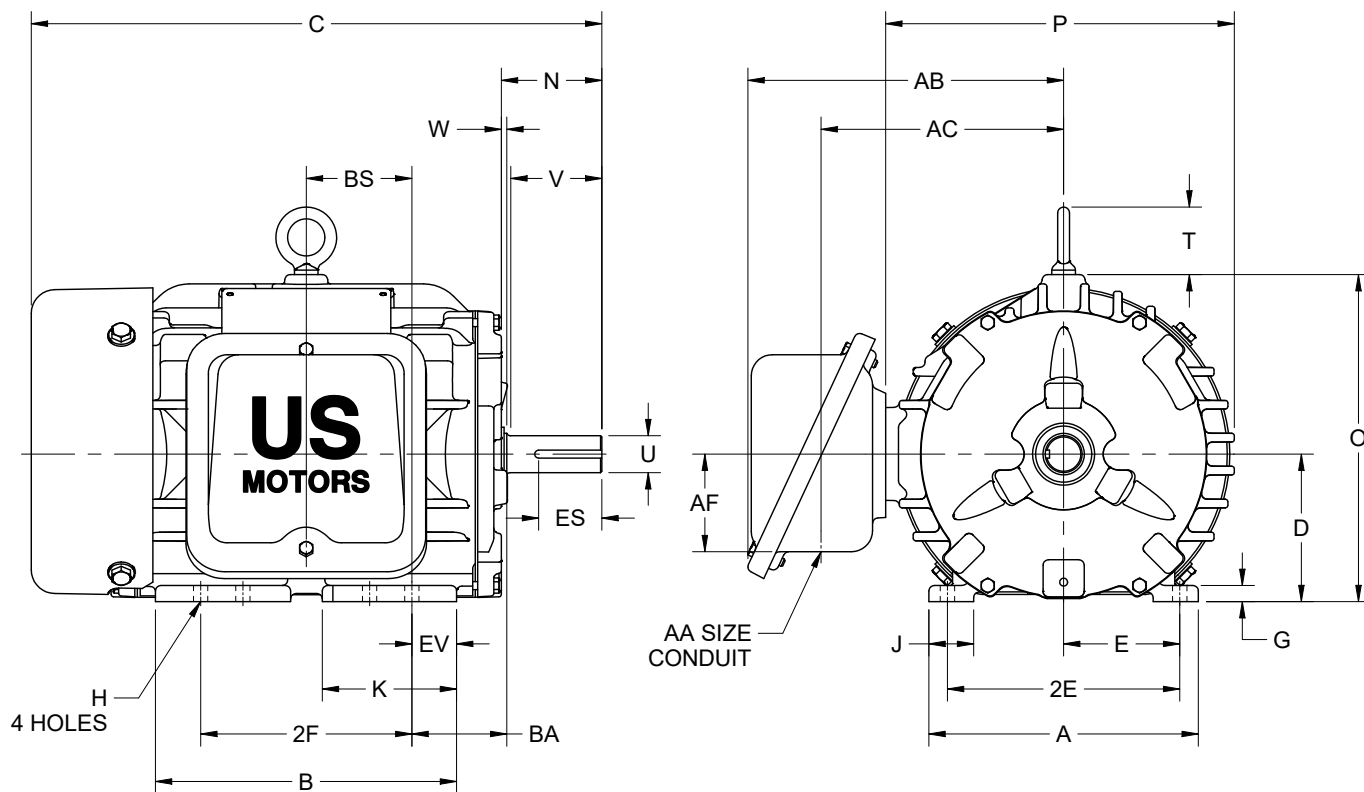

ALL DIMENSIONS ARE IN INCHES AND MILLIMETERS

UNITS	A	B	C	D -.06	E	2E ±.03	G	H +.05	J	K	N	O	P ²
IN	6.38	7.13	13.50	3.50	2.75	5.50	.38	.34	1.06	3.19	2.38	7.75	8.47
MM	162	181	343	89	70	140	10	9	27	81	60	197	215

UNITS	T	U -.0005	V MIN	W	AA	AB	AC	AF	BA	BS	EV	ES MIN	SQ KEY
IN	1.63	.8750	2.00	.13	3/4 NPT	7.50	5.75	2.31	2.25	2.50	1.06	1.41	.188
MM	17	22.225	51	3		191	146	59	57	64	27	36	4.78

FRAME	UNITS	2F ±.03
143T	IN	4.00
	MM	102
145T	IN	5.00
	MM	127

1. DIMENSIONS MAY VARY .25" DUE TO CASTING AND/OR FABRICATION VARIATIONS
2. LARGEST MOTOR WIDTH
3. STANDARD ASSEMBLY POSITION F-1 IS SHOWN. F-2 IS PROVIDED WHEN SPECIFIED. CONDUIT OPENING MAY BE LOCATED IN STEPS OF 90° REGARDLESS OF THE LOCATION
4. TOLERANCES ARE SHOWN IN INCHES ONLY

08-1055-01/B

Nidec Motor Corporation
St. Louis, Missouri

INFORMATION DISCLOSED ON THIS DOCUMENT IS CONSIDERED PROPRIETARY AND SHALL NOT BE REPRODUCED OR DISCLOSED WITHOUT WRITTEN CONSENT OF NIDEC MOTOR CORPORATION



ISSUED BY
I. GONZALEZ
APPROVED BY
R. TIMMERMANN

IHP_DP_NMCA (MAR-2011) SOLIDEDGE