

EFFECTIVE:
23-MAY-17

SUPERSEDES:
NEW

DIMENSION PRINT
WORLD MOTOR HOSTILE DUTY WITH CAST IRON OUTLET BOX
FRAME: 182T, 184T
BASIC TYPE: CT

PRINT:
08-1048-01

SHEET:
1 OF 1

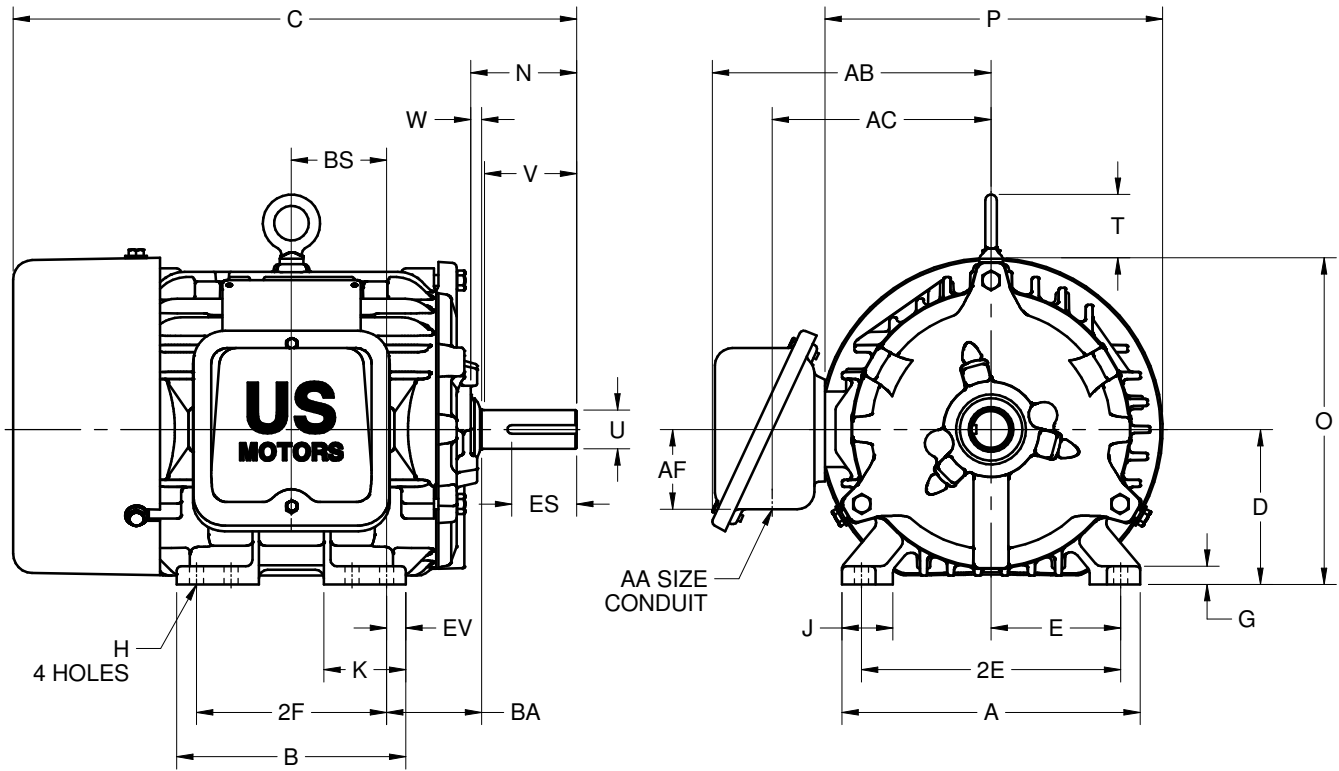

ALL DIMENSIONS ARE IN INCHES AND MILLIMETERS

UNITS	A	B	C	D -.06	E	2E ±.03	G	H +.05	J	K	N	O	P ²
IN	8.63	6.63	16.31	4.50	3.75	7.50	.53	.41	1.47	2.38	3.06	9.44	10.00
MM	219	168	414	114	95	191	13	10	37	60	78	240	254

UNITS	T	U -.001	V MIN	W	AA	AB	AC	AF	BA	BS	EV	ES MIN	SQ KEY
IN	1.84	1.1250	2.50	.31	3/4 NPT	8.06	6.34	2.31	2.75	2.75	.56	1.78	.250
MM	47	28.575	64	8		205	161	59	70	70	14	45	6.35

FRAME	UNITS	2F ±.03
182T	IN	4.50
	MM	114
184T	IN	5.50
	MM	140

1. DIMENSIONS MAY VARY .25" DUE TO CASTING AND/OR FABRICATION VARIATIONS
2. LARGEST MOTOR WIDTH
3. STANDARD ASSEMBLY POSITION F-1 IS SHOWN. F-2 IS PROVIDED WHEN SPECIFIED. CONDUIT OPENING MAY BE LOCATED IN STEPS OF 90° REGARDLESS OF THE LOCATION
4. TOLERANCES ARE SHOWN IN INCHES ONLY

08-1048-01/-

Nidec Motor Corporation
St. Louis, Missouri

INFORMATION DISCLOSED ON THIS DOCUMENT IS CONSIDERED PROPRIETARY AND SHALL NOT BE REPRODUCED OR DISCLOSED WITHOUT WRITTEN CONSENT OF NIDEC MOTOR CORPORATION



ISSUED BY
R. TIMMERMANN
 APPROVED BY
M. CULLEN

IHP_DP_NMCA (MAR-2011) SOLIDEDGE