

MODEL	REF	CUSTOMER	HP	VOLTS	AMPS	HZ	RPM	ROTATION	CATALOG NO.	DESCRIPTION / REMARKS
KA55ZZSKK-1152		STANDARD	1/5	230	1.4	60	1075/3 SPD	C.C.W. LEAD END	1152	

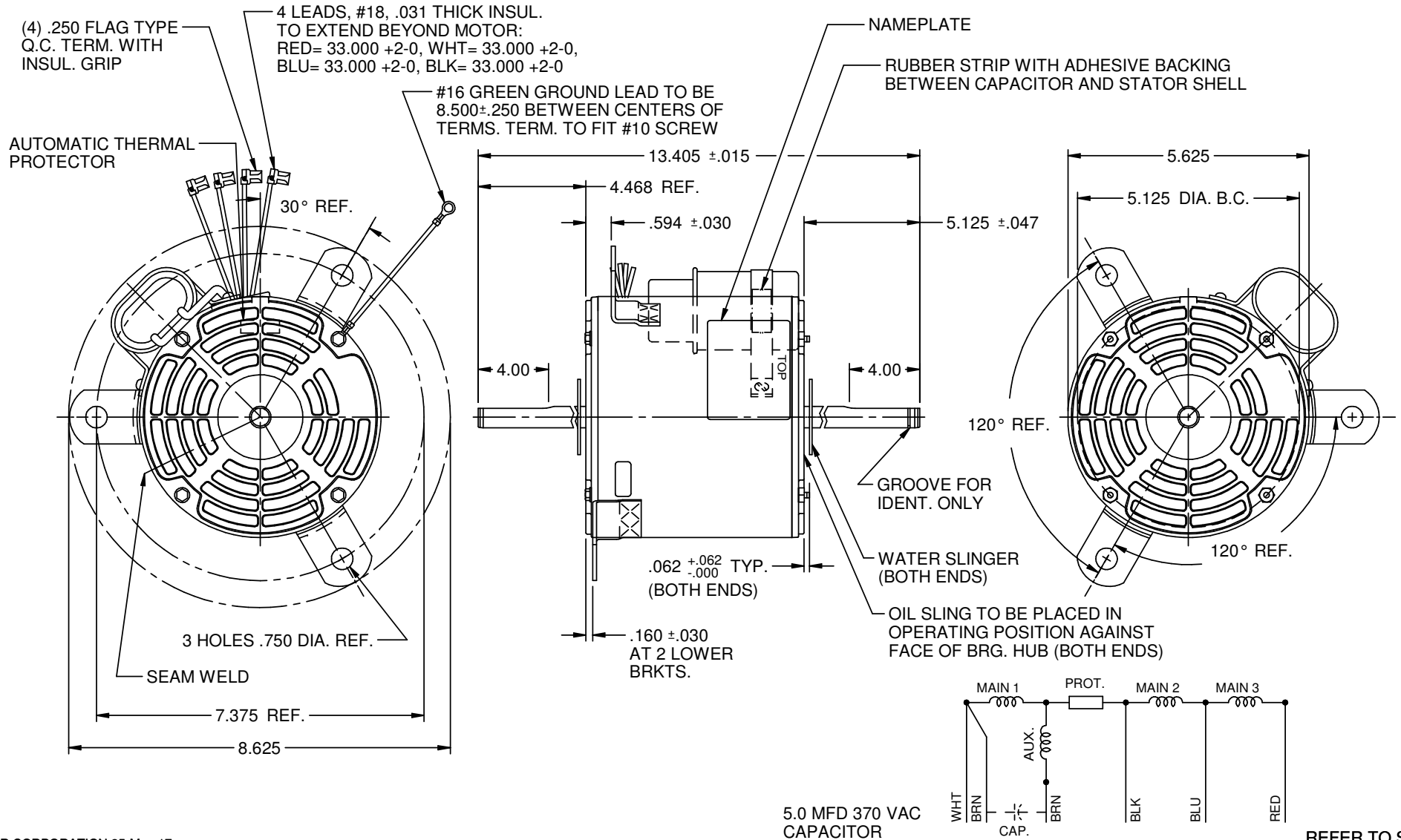

NIDEC MOTOR CORPORATION 25-May-17

REFER TO S.E.I.M. 24-1

REVISION RECORD FOR: E28700	
CREATED DRAWING:	
ISSUED BY: G. MEDINA	ENGINEER APPROVED: H. NAVARRO

DIMENSIONS ARE FOR REFERENCE ONLY
UNLESS TOLERANCE IS SPECIFIED

NIDEC MOTOR CORPORATION			
INFORMATION DISCLOSED ON THIS DOCUMENT IS CONSIDERED PROPRIETARY AND SHALL NOT BE REPRODUCED OR DISCLOSED WITHOUT WRITTEN CONSENT OF NIDEC MOTOR CORPORATION			
TITLE		CODE	ITEM NO.
CUSTOMER DETAIL DRAWING		V02	815753
		REV	SHEET NUMBER
		-	1 OF 3
		REVISION DATE: 23-MAY-17	
		DWG SIZE	B