



Product Catalog

# Packaged Rooftop Air Conditioners Precedent™ — Heat Pump

3 to 10 Tons — 60 Hz





# Introduction

## Packaged Heat Pumps

Trane® customers demand products that provide exceptional reliability, meet stringent performance requirements, and are competitively priced.

Precedent™ features cutting edge technologies: reliable compressors, Trane® engineered ReliaTel™ controls, computer-aided run testing, and Integrated Comfort™ Systems. So, whether you're the contractor, the engineer, or the owner you can be certain Precedent™ Products are built to meet your needs.

Through the years, Trane® has designed and developed the most complete line of Packaged Rooftop products available in the market today. Trane® was the first to introduce the Micro—microelectronic unit controls—and has continued to improve and revolutionize this design concept.

The ReliaTel™ control platform offers the same great features and functionality as the original Micro, with additional benefits for greater application flexibility.

With its sleek, compact cabinet, Precedent™ continues to provide the highest standards in quality and reliability, comfort, ease of service, and the performance of Trane® light commercial products.

## Copyright

This document and the information in it are the property of Trane, and may not be used or reproduced in whole or in part without written permission. Trane reserves the right to revise this publication at any time, and to make changes to its content without obligation to notify any person of such revision or change.

## Trademarks

All trademarks referenced in this document are the trademarks of their respective owners.

## Revision History

- Added EER2/SEER2, Low/High temp COP2 and HSPF2 data and footnote in the General Data chapter.
- Updated the Roof Curb values in Factory installed options table in the Weights chapter.



# Table of Contents

Introduction	2
Packaged Heat Pumps	2
Features and Benefits	5
Other Benefits	7
Standard Features	7
Factory Installed Options	10
Factory or Field Installed Options	14
Field Installed Options	15
Other Benefits	16
Application Considerations	19
Auxiliary Gas Heating Operation	19
Barometric Relief	19
Black Epoxy Coil	19
Clearance Requirements	19
Condensate Trap	19
Low Ambient Cooling	20
Optional Stainless Steel Heat Exchanger	20
Unit Pitch	20
Selection Procedure	21
Cooling Capacity	21
Heating Capacity	22
Air Delivery Selection	22
Model Number Descriptions	23
General Data	25
Gross Cooling Capacities	35
Evaporator Fan Performance	58
Fan Performance	100
Heating Performance Data	104
Controls	120
ReliaTel™	120
Economizer Controls	120
Differential Pressure Switches	122
RA Remote Sensor	122
Room Remote Sensor	122



## Table of Contents

---

Communication Interfaces .....	122
Electrical Data .....	124
Jobsite Connections .....	135
Dimensional Data .....	136
Weights .....	150
Mechanical Specifications .....	152
Standard .....	152
Factory Installed Options .....	153
Factory or Field Installed Options .....	156
Field Installed Options .....	158



# Features and Benefits

**Table 1. Precedent™ options — standard and optional**

	Standard Features	Options <sup>(a)</sup>		
		Factory Installed	Factory or Field Installed	Field Installed
1-year Limited Parts Warranty	X			
2" MERV 8 Filters or 2" MERV 13 Filters with Filter Removal Tool		X		
5-year Limited Compressor Warranty	X			
5-year Limited Heat Exchanger Warranty	X			
Anti-Short Cycle Timer (Standard with ReliaTel™)	X			
Auxiliary Gas Heat (High Efficiency Models Only)		X		
Barometric Relief			X	
Black Epoxy Pre-Coated Coils		X		
CO <sub>2</sub> Sensor Only Kit / CO <sub>2</sub> Sensor and Wiring Kit				X
CO <sub>2</sub> Sensor (Wiring Only)		X		
Clogged Filter/Fan Failure Switch			X	
Colored and Numbered Wiring	X			
Condensate Overflow Switch		X		
Convertible Airflow	X			
Crankcase Heaters	X			
Direct Drive Variable Speed Motors	X			
Discharge Air Temperature Sensing Kit			X	
Easy Access Low Voltage Terminal Board (LTB)	X			
Economizer: Low Leak				X
Economizer: Standard and Low Leak			X	
Electric Heaters			X	
Fault Detection and Diagnostics (FDD); Meets CA Title 24 Requirements		X		
Filters are Standard on all Units	X			
Foil-Faced and Edge Captured Insulation	X			
Frostat™			X	
Hail Guards			X	
Heat Exchanger	X			
High Altitude Kit				X
High Pressure Control	X			
High Static Motor			X	
Hinged Access Doors		X		
IAQ Dual Sloped, Plastic, Removable, Reversible Drain Pan	X			
Liquid Line Refrigerant Drier	X			
Low Ambient Cooling to 0°F	X			
Low Pressure Control	X			
Manual Outside Air Damper				X
Motorized Outside Air Dampers				X
Multispeed Direct Drive Motors on Select Models	X			
Multispeed Indoor Fan System		X		
Operating Charge of R-410A	X			
Outside Air Measuring/Monitoring Control (Traq Dampers)				X
Patent-Pending Hybrid Condenser Coil for easy cleaning	X			



## Features and Benefits

**Table 1. Precedent™ options — standard and optional (continued)**

	Standard Features	Options <sup>(a)</sup>		
		Factory Installed	Factory or Field Installed	Field Installed
Phase Loss Protection	X			
Phase Monitor	X			
Phase Reversal Protection	X			
Phase Balance Protection	X			
Plenum Fan on Select Models	X			
Powered Exhaust				X
Powered or Unpowered Convenience Outlet		X		
Provisions for Through-the-Base Condensate Drain Connections	X			
Quick Access Panels	X			
Quick Adapt Curbs				X
Quick Start Kit				X
Reference or Comparative Enthalpy			X	
Remote Potentiometer				X
Roof Curb				X
Single Point Power	X			
Single Side Service	X			
Single Zone Variable Air Volume (SZVAV)		X		
Stainless Steel Drain Pan		X		
Stainless Steel Heat Exchanger		X		
Standardized Components	X			
Supply, Return or Plenum Air Smoke Detector		X		
Thermal Expansion Valve	X			
Through-the-Base Electrical Access		X		
Through-the-Base Electrical with Circuit Breaker		X		
Through-the-Base Electrical with Disconnect Switch		X		
Touch Safe Control Box	X			
Ventilation Override Accessory				X

(a) Refer to model number description for option availability

**Table 2. Precedent™ control options — standard and optional**

	Standard Features	Options <sup>(a)</sup>		
		Factory Installed	Factory or Field Installed	Field Installed
BACnet® Communications Interface (BCI)			X	
Dual Thermistor Remote Zone Sensor				X
Human Interface		X		
LonTalk® Communications Interface (LCI)			X	
ReliaTel™ Microprocessor Controls	X			
Thermostat				X
Trane® Air-Fi® Wireless Communication Interface		X		
Trane® Communications Interface (TCI)			X	
Zone Sensor				X

(a) Refer to model number description for option availability.

## Other Benefits

- Cabinet design ensures water integrity
- Ease of Service, Installation and Maintenance
- Mixed model build enables “fastest in the industry” ship cycle times
- Outstanding Airflow Distribution
- ReliaTel™ Controls

## Standard Features

### Anti-Short Cycle Timer

Provides a 3 minute minimum “ON” time and 3 minute “OFF” time for compressors to enhance compressor reliability by assuring proper oil return.

### Colored And Numbered Wiring

Save time and money tracing wires and diagnosing the unit.

### Compressors

Precedent™ contains the best compressor technology available to achieve the highest possible performance.

Multi-stage compressors provide optimal performance during light load conditions.

### Condenser Coil



Precedent™ boasts a patent-pending 1+1+1 condenser coil, permanently gapped for easy cleaning.

### Controls – ReliaTel™

ReliaTel™ microprocessor controls provide unit control for heating, cooling and ventilating utilizing input from sensors that measure indoor and outdoor temperature and other zone sensors. ReliaTel™ also provides outputs for building automation systems and expanded diagnostics. For a complete list of ReliaTel™ offerings, refer to the “Other Benefits” section within the Features and Benefits section of this catalog.



## Features and Benefits

### Convertible Units



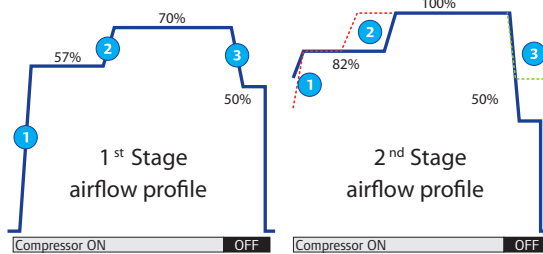
The units ship in a downflow configuration. They can be easily converted to horizontal by simply moving two panels.

Units come complete with horizontal duct flanges so the contractor doesn't have to field fabricate them. These duct flanges are a time and cost saver.

### Crankcase Heaters

These band heaters provide improved compressor reliability by warming the oil to prevent migration during off-cycles or low ambient conditions.

### Direct Drive Variable Speed Motors



Direct drive motor shall be variable speed with constant airflow settings. Motor will be ECM (Electronically Commutated Motor) as standard pre-programmed with enhanced airflow capabilities.

**Note:** Available on indoor motors for high efficiency 3 to 5 tons units only.

### Drain Pan



Every Precedent™ unit has a plastic, removable, dual-sloped drain pan that's easy to clean and reversible to allow installation of drain trap on either side of the unit.

### Dual Fuel

In heating mode, the unit control operates the heat pump in 1st stage heating. If the call for heat is not satisfied, heat pump 2nd stage is activated. If ambient is below lockout set point, the controller will activate auxiliary gas heat 1st stage, and heat pump operation will be terminated. A continued call for heat will cause the controller to activate auxiliary gas heat 2nd stage.

The indoor fan will continue to run and will switch to 100% during transition from heat pump to gas heat. If the controller initiates gas heat as the first heat source during a call for heat in constant volume, the blower is delayed 45 seconds to allow heat up of the gas heat exchanger.

If continuous fan operation is available and selected from the thermostat, the controller automatically adjusts fan speed for heat pump and gas heat operation.

During defrost mode, the controller will activate auxiliary gas heat to maintain comfort.



## Easy Access Low Voltage Terminal Board

Precedent's™ low voltage terminal board is external to the electrical control cabinet. It is extremely easy to locate and attach the thermostat wire and test operation of all unit functions. This is another cost and time saving installation feature.

## Foil Faced and Edge Captured Insulation

All panels in the evaporator section of the unit have cleanable foil-faced insulation. All edges are either captured or sealed to ensure no insulation fibers get into the airstream.

## Heat Exchanger

The compact cabinet features a progressive tubular heat exchanger in low, medium and high heat capacities. The heat exchanger is fabricated using stainless steel burners and corrosion-resistant aluminized steel tubes as standard on all models. It has an induced draft blower to pull the gas mixture through the burner tubes. The heater has a direct spark ignition system which doubles as a safety device to prove the flame.

## Low Ambient Cooling

All Precedent™ microprocessor units have cooling capabilities down to 0°F as standard.

## Low Voltage Connections

The wiring of the low voltage connections to the unit and the zone sensors is as simple as 1-1, 2-2, and 3-3. This simplified system makes it easy for the installer to wire.

## Phase Monitoring Protection

Precedent™ units with 3-phase power are equipped with phase monitoring protection as standard. These devices protect motors and compressors against problems caused by phase loss, phase imbalance and phase reversal indication.

## Plenum Fan

Select 6 to 10 tons models are equipped with a direct drive plenum fan design. Plenum fan design shall include a backward-curved fan wheel along with an external rotor direct drive variable speed indoor motor. All plenum fan designs will have a variable speed adjustment potentiometer located in the control box.

## Quick-Access Panels

Remove two screws for access to the standard internal components and wiring.

## Single Point Power

A single electrical connection powers the unit.

## Standardized Components

Components are placed in the same location on all Precedent™ units. Due to standardized components throughout the Precedent™ line, contractors/owners can stock fewer parts.

## Through-the-Base Condensate

Every unit includes provisions for through-the-base condensate drain connections. This allows the drain to be connected through the roof curb instead of a roof penetration.

## Touch Safe Control Box

On 3 to 5 tons modes, low voltage and high voltage components are separated within the control box. High voltage components are located behind a door to provide an additional layer of safety.

### Factory Installed Options

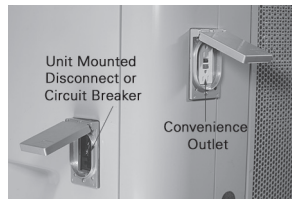
#### Black Epoxy Pre-Coated Coils

The pre-coated coils are an economical option for protection in mildly corrosive environments.

#### Circuit Breaker

This option is a factory installed thermal magnetic, molded case, HACR circuit breaker with provisions for through-the-base electrical connections.

**Note:** Available on units equipped with through-the-base electrical.



#### CO<sub>2</sub> Sensor Wiring

Factory-installed CO<sub>2</sub> sensor wiring saves time and ensures proper unit connections for the field installed CO<sub>2</sub> sensor kits.

#### Condensate Overflow Switch

A condensate overflow switch is available to shut the unit down in the event that the condensate drain line becomes clogged. This option protects the unit from water overflowing from the drain pan and entering the base of the unit.

#### Convenience Outlet



This option is a GFCI, 120V/15amp, 2 plug, convenience outlet, either powered or unpowered. This option can only be ordered when through-the-base electrical with either the disconnect switch or circuit breaker option is ordered.

**Note:** Not available on 10 tons, 575V units.

#### Disconnect Switch

Factory installed 3-pole, molded case, disconnect switch with provisions for through-the-base electrical connections are available.

Codes require a method of assured unit shutdown for servicing. Field-installed disconnects sometimes interfere with service access. Factory installation of unit disconnects reduces costs, assures proper mounting and provides the opportunity to upgrade to unit circuit breaker protection.

**Note:** Available on units equipped with through-the-base electrical.

### Fault Detection and Diagnostics (FDD)

This offering meets the mandatory requirement of CA Title 24 of fully configurable diagnostics allowing fault history and reading fault codes at the unit. This option provides detection of the following faults: Air temperature sensor failure/fault and notification of acceptable economizer mode. The FDD system shall be certified by the Energy Commission as meeting the requirements.

### High Efficiency Filtration

Precedent™ units offer a variety of high efficiency filtration options. MERV 8 and MERV 13 filters provide additional filtration beyond the capabilities of typical 2-inch throwaway filters. Also, when MERV 8 or MERV 13 filters are ordered, units come equipped with a filter removal tool.

### High Static Motor

Oversized motor for applications where higher external static pressure capability is required. Direct drive constant torque motors on 3 to 5 tons standard efficiency. Direct drive constant CFM motors on 3 to 5 tons high efficiency. A belt driven high static kit is available on standard efficiency 6 to 8.5 tons units.

### Hinged Access Doors

These doors permit easy access to the filter, fan/heat and compressor/control sections. They reduce the potential roof damage from screws or sharp access door corners.

**Note:** A compressor isolation panel is available for 3 to 5 tons units to ease commissioning and servicing of units.



### Human Interface - 5 Inch Color Touchscreen





## Features and Benefits

---

The 5 inch Color Touchscreen Human Interface provides an intuitive user interface to the rooftop unit that speeds up unit commissioning, shortens unit troubleshooting times, and enhances preventative maintenance measures. The human interface includes several features such as:

- Data trending capabilities by means of time series graphs
- Historical alarm messages
- Real-time sensor measurements
- On board system setpoints
- USB port that enables the downloading of component runtime information as well as trended historical sensor data
- Customized reports

**Note:** Refer to RT-SVX49\*-EN for additional information.

### Multi-Speed Indoor Fan System

Multi-speed indoor fan system is designed for use in applications for meeting the minimum requirement of CA Title 24.

This system incorporates a multi-speed fan control to change the speed of the fan to 66% of full airflow based off of compressor stages.

### Multiple-Zone VAV Control

A multiple-zone VAV (MZVAV) system consists of a packaged rooftop unit that serves several individually controlled zones. Each zone is equipped with a VAV terminal unit that varies the quantity of air delivered to maintain the desired temperature in that zone. The rooftop unit controller varies the speed of the indoor fan to maintain the static pressure in the supply ductwork at a setpoint, ensuring that all zones receive the necessary quantity of air. In addition, cooling capacity is cycled to maintain the supply air temperature at the desired setpoint.

For decades, Trane has been an industry leader in rooftop VAV systems. Now multiple-zone VAV control is available in high efficiency packaged heat pumps.

### Single Zone VAV (SZVAV)

Single zone variable air volume is designed for use in single zone applications like gymnasiums, auditoriums, manufacturing facilities, retail box stores, and any large open spaces, where there is a lot of diversity in the load profile. SZVAV is an ideal replacement to “yesterday’s” constant volume (CV) systems, by reducing operating costs while improving occupant comfort. SZVAV systems combine Trane® application, control and system integration knowledge to exactly match fan speed with cooling and heating loads, regardless of the operating condition. Trane® algorithms meet/exceed ASHRAE 90.1- 2010, SZVAV energy-saving recommendations, and those of CA Title 24. The result is an optimized balance between zone temperature control and system energy savings. Depending on your specific application, energy savings can be as much as 20+%.

**Note:** Building system modeling in energy simulation software like TRACE is recommended to evaluate performance improvements for your application.

Single zone variable air volume is fully integrated into the ReliaTel™ control system and is available today. It provides the simplest and fastest commissioning in the industry through proven factory-installed, wired, and tested system controllers. All control modules, logic and sensors are factory installed, and tested to assure the highest quality and most reliable system available. This means no special programming of algorithms, or hunting at the jobsite for sensors, boards, etc. that need to be installed in the field. SZVAV is a quick and simple solution for many applications and is available from your most trusted rooftop VAV system solution provider - Trane®.

### Stainless Steel Drain Pan

For excellent corrosion and oxidation resistance, the optional stainless steel drain pan provides a cleanable surface that complement other IAQ solutions such as high efficiency filtration (MERV 8 or 13) and demand control ventilation (CO<sub>2</sub>).

### Stainless Steel Heat Exchanger

The optional stainless steel heat exchanger is constructed of 409 stainless steel. It is resistant to corrosion and oxidation and easy to clean. The high strength to weight ratio allows for high ventilation rates with gas units. It is an excellent option to complement the dehumidification option as a high outside air ventilation unit. With this option, a 10-year stainless steel heat exchanger warranty is standard.

### Supply, Return, and Plenum Air Smoke Detector

With this option installed, if smoke is detected, all unit operation will be shut down. Reset will be manual at the unit. In order for the supply air smoke detector or return air smoke detector to properly sense smoke in the supply air stream or the return air stream, the air velocity entering the smoke detector unit must be between 500 - 4000 feet per minute. Equipment covered in this manual will develop an airflow velocity that falls within these limits over the entire airflow range specified in the evaporator fan performance table. Supply and/or return smoke detectors may not be used with the plenum smoke detector.

**Note:** *Plenum smoke detectors have no auxiliary contacts for external connections.*

**Figure 1. Supply/Return air smoke detector    Figure 2. Plenum air smoke detector**



### Through-the-Base Electrical Utility Access

An electrical service entrance shall be provided allowing electrical access for both control and main power connections inside the curb and through-the-base of the unit. Option will allow for field installation of liquid-tight conduit and an external field installed disconnect switch.

Factory provided through-the-base openings simplify wiring and piping. Because these utility openings frequently minimize the number of roof penetrations, the integrity of roofing materials is enhanced.



## Features and Benefits

---

### Through-the-Base Gas Access

Factory provided through-the-base openings simplify wiring and piping. Because these utility openings frequently minimize the number of roof penetrations, the integrity of roofing materials is enhanced.



## Factory or Field Installed Options

### Barometric Relief

Designed to be used on downflow units, barometric relief is an unpowered means of relieving excess building pressure.

### Clogged Filter/Fan Failure Switch

A dedicated differential pressure switch is available to achieve active fan failure indication and/or clogged filter indication.

These sensors allow a zone sensor service light to indicate a dirty filter or a fan that's not working. The field installation charges for these valuable feedback devices often eliminate them from consideration. Factory installation can make such features a good investment.

### Discharge Air Temperature Sensing Kit

Provides true discharge air temperature sensing in heating models. The kit is functional only with the ReliaTel™ options module.

### Economizer (Standard)

This accessory shall be available with or without barometric relief. The assembly includes fully modulating 0-100 percent motor and dampers, minimum position setting, preset linkage, wiring harness with plug, spring return actuator and fixed dry bulb control. The barometric relief shall provide a pressure operated damper that shall be gravity closing and shall prohibit entrance of outside air during the equipment "off" cycle. Optional solid state or differential enthalpy control shall be available for either factory or field installation. The economizer arrives in the shipping position and shall be moved to the operating position by the installing contractor.

### Electric Heaters

Electric heat modules are available within the basic unit. If ordering the through-the-base electrical option with an electrical heater, the heater must be factory installed.

### Fresh Air Options – Dampers and Economizer

0 to 25% manual or 0 to 50% motorized outside air hoods are available.

Economizers are equipped with either dry bulb or reference or comparative enthalpy sensing. These economizers provide free cooling as the outdoor temperature and/or humidity decreases. Correctly installed, they offer a valuable energy savings. Factory-installed economizers save time and ensure proper installation.

Due to varying supply fan speed 0 to 50% motorized damper is not available with multi-speed or SZVAV applications.

The economizers come with three control options — dry bulb is standard, enthalpy and differential enthalpy are optional.

### **Frostat™**

This capillary bulb embedded in the face of the evaporator coil monitors coil temperature to prevent evaporator icing and protect the compressor. Recommended for applications with low leaving air temperatures, low airflow and or high latent load applications.

### **Hail Guards**

Hail protection quality coil guards protects the condenser coil from vandalism and/or hail damage.

### **Low Leak Economizer**

This accessory meets low leak requirements for ASHRAE 90.1, IECC, and CA Title 24 standards (4 cfm/ft<sup>2</sup>@1" wg exterior air/return air). This option allows 100% outdoor air supply from 0 to 100% modulating dampers and is standard with barometric relief. It can be paired with powered exhaust for additional building pressure relief. This option can be paired with or without Fault Detection and Diagnostics (FDD) to meet current mandatory CA Title 24 requirements.

*Note: Available on downflow units only.*

### **Reference or Comparative Enthalpy**

Measures and communicates humidity while maximizing comfort control.

## **Field Installed Options**

### **CO<sub>2</sub> Sensing Kits**

Two field installed kits are offered: CO<sub>2</sub> sensor and wiring or CO<sub>2</sub> sensor only. The CO<sub>2</sub> sensor only kit should be ordered with factory installed CO<sub>2</sub> sensor wiring. Factory installed CO<sub>2</sub> sensor wiring saves set-up time and ensures proper unit connections for the CO<sub>2</sub> sensor.

The CO<sub>2</sub> sensor has the ability to monitor space occupancy levels within the building by measuring the parts per million of CO<sub>2</sub> (Carbon Dioxide) in the air. As the CO<sub>2</sub> levels increase, the outside air damper modulates to meet the CO<sub>2</sub> space ventilation requirements.

### **High Altitude Kit**

While recommended for units applied above 2000 feet, domestic contractors should consult with local authority on best practice. High altitude kits contain gas orifices that derate the gas input rate (Btu/hr) by 10%.

### **Low Leak Economizer - Field Installed**

This accessory meets low leak requirements for ASHRAE 90.1, IECC, and CA Title 24 standards (4 cfm/ft<sup>2</sup>@1" wg exterior air/return air). This option allows 100% outdoor air supply from 0-100% modulating dampers and is standard with barometric relief. It can be paired with powered exhaust for additional building pressure relief.

*Note: Available on downflow units only.*

### **Outside Air Measuring/Monitoring Control (TraQ Dampers)**

Quantity of fresh air entering the unit will be measured and monitored via Trane UC400 controller and series of pressure sensing rings mounted at the outside air intake.

### **Quick Adapt Curbs**

Enables easy conversion of existing Voyager™ 3 to 10 tons units to Precedent™ units on replacement jobs.



## Features and Benefits

---

### Roof Curbs

Available for downflow units. Only three roof curbs for the entire line simplifies curb selection.

### Remote Potentiometer

When properly installed in the economizer control circuitry, this accessory provides a remote variable resistance to enable the operator to adjust the minimum damper position.

### Ventilation Override Accessory

With the ventilation override accessory installed, the unit can be set to transition to up to 3 different pre-programmed sequences for smoke purge, pressurization, and exhaust. The transition occurs when a binary input on the RTOM is closed (shorted). This would typically be a hard wired relay output from a smoke detector or fire control panel. The ventilation override kit is available as a field installed accessory.

## Other Benefits

### Airflow Distribution

Airflow is outstanding. Precedent™ can replace an older machine with old ductwork and, in many cases, improve the comfort through better air distribution.

### Cabinet Integrity

For added water integrity, Precedent™ has a raised 1 1/8-inch lip around the supply and return of the downflow units to prevent water from blowing into the ductwork.

The compact cabinet with rounded corners takes up less room. The beveled and ribbed top is aesthetically pleasing and designed to prevent water from pooling.



### Easy to Install, Service and Maintain

Because today's owners are very cost-conscious when it comes to service and maintenance, the Precedent™ unit was designed with direct input from service contractors. This valuable information helped to design a product that would get the service person off the job quicker and save the owner money. Precedent™ offers outstanding standard features enhanced by a variety of factory and field installed options, multiple control options, rigorously tested proven designs and superior product and technical support.

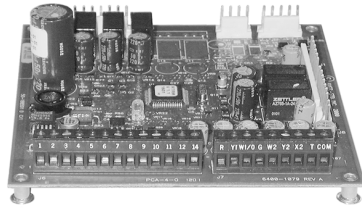
### Flexibility

Precedent™ offers ultimate flexibility. Units are built to order in our standard "shortest in the industry" ship cycle time.



## ReliaTel™ Controls

**Figure 3. ReliaTel board**



ReliaTel controls provide unit control for heating, cooling, and ventilating, utilizing input from sensors that measure outdoor and indoor temperature. ReliaTel also provides outputs for building automation systems and expanded diagnostics. Quality and reliability are enhanced through ReliaTel control and logic:

- Prevents the unit from short cycling, considerably improving compressor life.
- Ensures the compressor will run for a specific amount of time which allows oil to return for better lubrication, enhancing the reliability of the compressor.
- Reduces the number of components required to operate the unit, reducing possibilities for component failure.

### **ReliaTel Makes Installing and Servicing Easy**

ReliaTel eliminates the need for field-installed, anti-short cycle timer and time delay relays. The wiring of the low voltage connections to the unit and the zone sensors is as easy as 1-1, 2-2, and 3-3. This simplified system makes wiring easier for the installer.

### **ReliaTel Makes Testing Easy**

ReliaTel requires no special tools to run the unit through its paces. Simply place a jumper between Test 1 and Test 2 terminals on the Low Voltage Terminal Board and the unit will walk through its operational steps automatically. The unit automatically returns control to the zone sensor after stepping through the test mode a single time, even if the jumper is left on the unit. As long as the unit has power and the “system on” LED is lit, ReliaTel is operational. The light indicates that the controls are functioning properly. ReliaTel features expanded diagnostic capabilities when utilized with Trane Integrated Comfort™ Systems. Some zone sensor options have central control panel lights which indicate the mode the unit is in and possible diagnostic information (dirty filters for example).

### **ReliaTel Has Other Benefits**

- The ReliaTel built-in anti-shortcycle timer, time delay relay and minimum “on” time control functions are factory tested to assure proper operation.
- ReliaTel softens electrical “spikes” by staging on fans, compressors and heaters.
- Intelligent Fallback is a benefit to the building occupant. If a component goes astray, the unit will continue to operate at predetermined temperature setpoint.
- Intelligent Anticipation is a standard feature. It functions continuously as ReliaTel and zone sensor(s) work together in harmony to provide much tighter comfort control than conventional electromechanical thermostats.
- The ReliaTel design is standardized across the board, ensuring a lower cost to owners.



## Features and Benefits

---

### Rigorous Testing

All of Precedent's™ designs were rigorously rain tested at the factory to ensure water integrity.

Actual shipping tests were performed to determine packaging requirements. Units were test shipped around the country to determine the best packaging. Factory shake and drop tests were used as part of the package design process to help assure that the unit arrives at the job site in top condition.

Rigging tests include lifting a unit into the air and letting it drop one foot, assuring that the lifting lugs and rails hold up under stress.

We perform a 100% coil leak test at the factory. The evaporator and condenser coils are leak tested at 600 psig. The assembled unit is leak tested to 465 psig.

All parts are inspected at the point of final assembly. Sub-standard parts are identified and rejected immediately.

Every unit receives a 100% unit run test before leaving the production line to make sure it meets rigorous requirements.



# Application Considerations

Application of this product should be within the cataloged airflow and cooling considerations.

## Auxiliary Gas Heating Operation

The heat exchanger is manufactured with aluminized steel. To prevent condensation within the heat exchanger, do not exceed 50% outside air or a minimum mixed air temperature of 40°F.

## Barometric Relief

This product line offers an optional barometric relief damper for use in conjunction with economizer option. This accessory consists of gravity dampers which open with increased pressure. As the building air pressure increases, the pressure in the unit return air section also increases, opening the dampers and relieving the conditioned space.

**Note:** *The effectiveness of barometric relief damper during economizing operation is limited, depending on the pressure drop of the return-air path. For some applications, powered exhaust may be better suited for preventing over-pressurization when economizing.*

## Black Epoxy Coil

The coils are manufactured with a thermoset, vinyl coating that is bonded to the aluminum fin stock prior to the fin stamping process. These coils are an economical option for protection in mildly corrosive environments.

**Note:** *Not to be used where seacoast applications exist.*

## Clearance Requirements

The recommended clearances identified with unit dimensions should be maintained to assure adequate service maximum capacity and peak operating efficiency. Actual clearances which appear inadequate should be reviewed with the local Trane® sales personnel.

Model Number	Clearance required from duct to combustible surfaces (inches)
WSC036H	0
WSC048H	0
WSC060H	0
WSC092H	1
WSC102H	1
WSC120H	1
D/WHC036H	0
D/WHC048H	0
D/WHC060H	0
D/WHC074H	1
D/WHC092H	1
D/WHC102H	1
D/WHC120H	1

## Condensate Trap

The evaporator is a draw-thru configuration. A trap must be field provided prior to start-up on the cooling cycle.



## Application Considerations

---

### Low Ambient Cooling

The Precedent™ line features, with ReliaTel™ microprocessor controls, low ambient cooling down to 0°F. The following features or options need to be included/considered when low ambient applications are required: continuous fan operation, crankcase heaters, thermal expansion valves, froststat.

Contact a local Trane® representative for more assistance with low ambient cooling applications.

### Optional Stainless Steel Heat Exchanger

The optional stainless steel heat exchanger is manufactured with 409 stainless steel. To prevent corrosion and prolong heat exchanger reliability, the minimum mixed air temperature allowed across the heat exchanger is 20°F.

The stainless steel heat exchanger option is an excellent option that compliments the dehumidification package. Whenever high outside air or outside applications exist, these options should be utilized.

### Unit Pitch

The unit has a reversible sloped condensate drain pans. The unit must be installed level. Any unit slope must be toward the side of unit where condensate drain is connected.



# Selection Procedure

## Cooling Capacity

1. Calculate the building's total and sensible cooling loads at design conditions. Use the Trane® calculation methods or any other standard accepted method.

Factors used in unit selection:

- Total Cooling Load: 58 MBh
- Sensible Cooling Load: 37 MBh
- Airflow: 2000 cfm
- Electrical Characteristics: 460/60/3
- Summer Design Conditions: Entering
- Evaporator Coil: 80 DB, 67 WB Outdoor Ambient: 95
- External Static Pressure: 0.47 in. wg
- Downflow Configuration
- Economizer

2. As a starting point, a rough determination must be made of the size of the unit. The final selection will be made after examining the performance at the given conditions. Divide the total cooling load by nominal BTUH per ton (12 MBh per ton); then round up to the nearest unit size.

$$58 \text{ MBh} / 12 \text{ MBh} = \text{approx. } 5 \text{ tons}$$

3. [Table 12, p. 37](#) shows that a WSC060H4 has a **gross** cooling capacity of 61.0 MBh and 48.8 MBh sensible capacity at 2000 cfm and 95 DB outdoor ambient with 80 DB, 67 WB air entering the evaporator.

### To Find Capacity at Intermediate Conditions not in the table

When the design conditions are between two numbers that are in the capacity table, interpolation is required to approximate the capacity.

**Note:** *Extrapolation outside of the table conditions is not recommended.*

4. In order to select the correct unit which meets the building's requirements, the fan motor heat must be deducted from the gross cooling capacity. The amount of heat that the fan motor generates is dependent on the effort by the motor - cfm and static pressure. To determine the total unit static pressure:

External Static Duct System	0.52 wg
Economizer from <a href="#">Table 83, p. 102</a> (100% Outside Air)	0.11 wg
Electric Heater Size 9 kW from <a href="#">Table 83, p. 102</a>	0.02 wg
Total Static Pressure	0.65 wg

**Note:** Refer "[Heating Capacity](#)," [p. 22](#) section on this page for determination of heater size.

With 2000 cfm and 0.65 wg, [Table 35, p. 59](#) shows 0.44 bhp for this unit. Note below the table gives a formula to calculate Fan Motor Heat,

$$2.87 \times \text{bhp} + 0.15 = \text{MBh}$$

$$2.87 \times 0.44 + 0.15 = 1.41 \text{ MBh}$$

Now subtract the fan motor heat from the gross cooling capacity of the unit:

$$\begin{aligned} \text{Net Total Cooling Capacity} \\ = 61.0 \text{ MBh} - 1.41 = 59.59 \text{ MBh} \end{aligned}$$

$$\begin{aligned} \text{Net Sensible Cooling Capacity} \\ = 48.8 \text{ MBh} - 1.41 = 47.39 \text{ MBh} \end{aligned}$$



## Selection Procedure

---

5. Compare results to original load requirements. If the performance will not meet the required total or sensible cooling load, try a selection at the next higher size unit.

## Heating Capacity

1. Calculate the building heating load using the Trane® calculation form or other standard accepted method.

2. Size the equipment using [Table 86, p. 106](#) to match the heating loads at design conditions.

Total heating load of 53 MBh

Outdoor Ambient (Winter): 17 DB

Indoor Return Temperature: 60 DB

Airflow: 2000 cfm

Use the integrated portion of [Table 86, p. 106](#) for WSC060 to determine capacity at winter design conditions. The mechanical heating portion of the heat pump will provide 36.2 MBh.

3. Because 36.2 is less than the building's required heating capacity at winter design conditions, a supplementary heater must be selected.

$53 \text{ MBh} - 36.2 \text{ MBh} = 16.8 \text{ MBh}$

The auxiliary electric heat capacities are listed in [Table 104, p. 117](#). From the table, a 6 kW heater will deliver 20.48 MBh at 480 volts. In order to determine capacity at 460 volts, the heater voltage correction factor from [Table 106, p. 118](#) must be used. Therefore,  $20.48 \text{ MBh} \times .918$  (voltage correction factor) = 18.8 MBh. A 6 kW heater should be selected.

## Air Delivery Selection

External static pressure drop through the air distribution system has been calculated to be 0.65 inches of water. Enter [Table 35, p. 59](#) for a WSC060H4 at 2000 cfm and 0.65 static pressure. The belt drive motor will give the desired airflow at a rated bhp of 0.44 and 766 rpm.



# Model Number Descriptions

## Digit 1 - Unit Type

- W = Packaged Heat Pump<sup>2</sup>
- D = Dual Fuel Heat Pump<sup>2</sup>

## Digit 2 - Efficiency

- S = Standard Efficiency
- H = High Efficiency

## Digit 3 - Airflow

- C = Convertible

## Digit 4,5,6 - Nominal Gross Cooling Capacity (MBh)

- 036 = 3 Ton
- 048 = 4 Ton
- 060 = 5 Ton
- 074 = 6 Ton
- 092 = 7.5 Ton
- 102 = 8.5 Ton
- 120 = 10 Ton

## Digit 7 - Major Design Sequence

### Digit 8 - Voltage Selection

- 3 = 208-230/60/3
- 4 = 460/60/3
- W = 575/60/3

### Digit 9 - Unit Controls

- R = ReliaTel™ Microprocessor

### Digit 10 - Heating Capacity

**Note:** *Applicable to Digit 1, W models only.*

- 0 = No Electric Heat
- B = 6 kW
- C = 9 kW
- E = 12 kW
- G = 18 kW
- J = 23 kW
- K = 27 kW
- N = 36 kW
- P = 54 kW

**Note:** *Applicable to Digit 1, D models only*

- L = Low Heat
- M = Medium Heat
- H = High Heat
- X = Low Heat, Stainless Steel Heat Exchanger
- Y = Medium Heat, Stainless Steel Heat Exchanger
- Z = High Heat, Stainless Steel Heat Exchanger

### Digit 11 - Minor Design Sequence

### Digit 12,13 - Service Sequence

\*\* Factory Assigned

### Digit 14 - Fresh Air Selection

- 0 = No Fresh Air
- A = Manual Outside Air Damper 0-50%<sup>1</sup>
- B = Motorized Outside Air Damper 0-50%<sup>10</sup>
- C = Economizer, Dry Bulb 0-100% without Barometric Relief<sup>4</sup>
- D = Economizer, Dry Bulb 0-100% with Barometric Relief<sup>4</sup>

- E = Economizer, Reference Enthalpy 0-100% without Barometric Relief<sup>4</sup>

- F = Economizer, Reference Enthalpy 0-100% with Barometric Relief<sup>4</sup>

- G = Economizer, Comparative Enthalpy 0-100% without Barometric Relief<sup>4</sup>

- H = Economizer, Comparative Enthalpy 0-100% with Barometric Relief<sup>4</sup>

- K = Low Leak Economizer with Barometric Relief

- M = Low Leak Economizer with Reference Enthalpy with Barometric Relief

- P = Low Leak Economizer with Comparative Enthalpy with Barometric Relief

### Digit 15 - Supply Fan/Drive Type/Motor

- 0 = Standard Drive<sup>3</sup>
- 1 = Oversized Motor<sup>3</sup>
- 2 = Optional Belt Drive Motor
- 6 = Single Zone Variable Air Volume (SZVAV)<sup>14</sup>
- 7 = Multi-Speed Indoor Fan<sup>12</sup>
- 8 = Single Zone Variable Air Volume (SZVAV) w/Oversized Motor<sup>14</sup>
- E = Multi-Zone Variable Air Volume (MZVAV)<sup>14</sup>
- F = Multi-Zone Variable Air Volume (MZVAV) w/Oversized Motor<sup>14</sup>

### Digit 16 - Hinged Service Access/ Filters

- 0 = Standard Panels/Standard Filters
- A = Hinged Access Panels/Standard Filters
- B = Standard Panels/2" MERV 8 Filters
- C = Hinged Access Panels/2" MERV 8 Filters
- D = Standard Panels/2" MERV 13 Filters
- E = Hinged Access Panels/2" MERV 13 Filters

### Digit 17 - Condenser Coil Protection

- 0 = Standard Coil
- 1 = Standard Coil with Hail Guard
- 2 = Black Epoxy Pre-Coated Condenser Coil
- 3 = Black Epoxy Pre-Coated Condenser Coil with Hail Guard

### Digit 18 - Through-the-Base Provisions

- 0 = No Through-the-Base Provisions
- A = Through-the-Base Electric<sup>5</sup>
- B = Through-the-Base Gas Piping<sup>17</sup>
- C = Through-the-Base Electric and Gas Piping<sup>17</sup>

### Digit 19 - Disconnect/Circuit Breaker (three-phase only)

- 0 = No Disconnect/No Circuit Breaker
- 1 = Unit Mounted Non-Fused Disconnect<sup>5</sup>
- 2 = Unit Mounted Circuit Breaker<sup>5</sup>

### Digit 20 - Convenience Outlet

- 0 = No Convenience Outlet
- A = Unpowered Convenience Outlet
- B = Powered Convenience Outlet (three-phase only)<sup>6</sup>

### Digit 21 - Communications Options

- 0 = No Communications Interface
- 1 = Trane® Communications Interface
- 2 = LonTalk® Communications Interface
- 6 = BACnet® Communications Interface
- 7 = Air-Fi® Wireless Communications<sup>15</sup>

### Digit 22 - Refrigeration System Option

- 0 = Standard Refrigeration System<sup>7</sup>

### Digit 23 - Refrigeration Controls

- 0 = No Refrigeration Control<sup>2</sup>
- 1 = Froststat™<sup>11</sup>
- 2 = Crankcase Heater<sup>16</sup>
- 3 = Froststat and Crankcase Heater<sup>11,16</sup>

### Digit 24 - Smoke Detector

- 0 = No Smoke Detector
- A = Return Air Smoke Detector<sup>8</sup>
- B = Supply Air Smoke Detector
- C = Supply and Return Air Smoke Detectors<sup>8</sup>
- D = Plenum Smoke Detector

### Digit 25 - System Monitoring Controls

- 0 = No Monitoring Control
- 1 = Clogged Filter Switch
- 2 = Fan Failure Switch
- 3 = Discharge Air Sensing Tube
- 4 = Clogged Filter Switch and Fan Fail Switch
- 5 = Clogged Filter Switch and Discharge Air Sensing Tube
- 6 = Fan Fail Switch and Discharge Air Sensing Tube
- 7 = Clogged Filter and Fan Fail Switches and Discharge Air Sensing Tube
- A = Condensate Drain Pan Overflow Switch
- B = Clogged Filter Switch and Condensate Drain Pan Overflow Switch
- C = Fan Failure Switch and Condensate Drain Pan Overflow Switch
- D = Discharge Air Sensing and Condensate Drain Pan Overflow



## Model Number Descriptions

---

- E = Switch  
Clogged Filter Switch, Fan Failure Switch and Condensate Drain Pan Overflow Switch
- F = Clogged Filter Switch, Discharge Air Sensing Tube and Condensate Drain Pan Overflow Switch
- G = Fan Failure Switch, Discharge Air Sensing Tube and Condensate Drain Pan Overflow Switch
- H = Clogged Filter Switch, Fan Failure Switch, Discharge Air Sensing and Condensate Drain Pan Overflow Switch

### Digit 26 - System Monitoring Controls

- 0 = No Monitoring Controls
- A = Demand Control Ventilation (CO<sub>2</sub>)<sup>13</sup>
- B = Low Leak Economizer with FDD (Fault Detection and Diagnostics)
- C = FDD (Fault Detection and Diagnostics) with DCV (Demand Control Ventilation)

### Digit 27 - Unit Hardware Enhancements

- 0 = No Enhancements
- 1 = Stainless Steel Drain Pan

### Digit 31 - Advanced Unit Controls

- 0 = Standard Unit Controls
- 1 = Human Interface

## Model Number Notes

1. Manual outside air damper will ship factory supplied within the unit, but must be field installed.
2. High pressure control is standard on all units.
3. Multi-stage, direct drive standard on 3 to 5 tons models. Belt drive standard on 6 to 8.5 tons standard efficiency models. Variable speed direct drive standard on 10 tons models and 6 to 8.5 tons high efficiency models.
4. Economizer with barometric relief is for downflow configured units only. Order economizer without barometric relief for horizontal configuration. Barometric relief for horizontal configured units must be ordered as field installed accessory.
5. Through-the-base electric required when ordering disconnect/circuit breaker options.
6. Requires use of disconnect or circuit breaker.
7. Standard metering devices are TXVs.
8. The return air smoke detector may not fit up or work properly on the Precedent™ units when used in conjunction with 3rd party accessories such as bolt on heat wheels, economizers and power exhaust. Do not order the return air smoke detectors when using this type of accessory.
9. Requires hinged access panels.
10. Motorized outside air damper is not available on Multi-Speed or SZVAV (Single Zone Variable Air Volume) or MZVAV (Multi Zone Variable Air Volume) products.
11. Froststat™ standard on 6 to 10 tons high efficiency heat pump, multi-speed and SZVAV (single zone variable air volume) products.
12. Multi-speed indoor fan available on 6, 7.5, 8.5 and 10 tons products.
13. Demand control ventilation option includes wiring only. The CO<sub>2</sub> sensor is a field-installed only option.
14. SZVAV/MZVAV is available on all high efficiency models. SZVAV is also available on 7.5 to 10 tons standard efficiency models.
15. Must be used with BACnet® open protocol.
16. Crankcase heater is standard on all 3 to 10 tons heat pumps.
17. Includes gas piping and shutoff (field assembly required).





# General Data

**Table 3. General data - 3 to 5 tons - standard efficiency**

	<b>3 Tons</b>	<b>4 Tons</b>	<b>5 Tons</b>
	<b>WSC036H3,4,W</b>	<b>WSC048H3,4,W</b>	<b>WSC060H3,4,W</b>
<b>Cooling Performance<sup>(a)</sup></b>			
Gross Cooling Capacity	39,500	50,000	61,000
EER/SEER <sup>(b)</sup>	3,4 = 12.1/14.3 W = 12.0/14.3	3,4 = 12.3/14.3 W = 12.2/14.3	3,4 = 12.3/14.3 W = 12.2/14.3
EER2/SEER2 <sup>(c)</sup>	10.6/13.4	10.6/13.4	10.6/13.4
Nominal cfm/AHRI Rated cfm	1,200/1,200	1,600/1,600	2,000/2,000
AHRI Net Cooling Capacity	39,000	49,000	60,000
System Power (kW)	3.22	3.98	4.88
<b>Heating Performance<sup>(d)</sup></b>			
High Temp. Btuh Rating	36,000	47,500	59,000
System Power kW/COP	3.01/3.50	3.98/3.50	4.94/3.50
System Power kW/COP2	3.22/3.40	3.92/3.50	4.86/3.50
Low Temp. Btuh Rating	20,600	26,000	35,000
System Power kW/COP	2.74/2.20	3.31/2.30	4.46/2.30
System Power kW/COP2	2.71/2.20	3.57/2.30	4.35/2.30
HSPF (Btu/Watts-hr)	8.00	8.20	8.20
HSPF2	7.20	7.20	7.20
<b>Compressor</b>			
Number/Type	1/Scroll	1/Scroll	1/Scroll
<b>Sound</b>			
Outdoor Sound Rating (dB) <sup>(e)</sup>	81	82	87
<b>Outdoor Coil</b>			
Type	Lanced	Lanced	Lanced
Tube Size (in.)	0.3125	0.3125	0.3125
Face Area (sq. ft.)	12.33	12.33	17.00
Rows/FPI	2/16	3/16	3/16
Refrigerant Control	Thermal Expansion Valve	Thermal Expansion Valve	Thermal Expansion Valve
<b>Indoor Coil</b>			
Type	Lanced	Lanced	Lanced
Tube Size (in.)	0.3125	0.3125	0.3125
Face Area (sq. ft.)	8.74	8.74	9.27
Rows/FPI	3/16	3/16	3/16
Refrigerant Control	Thermal Expansion Valve	Thermal Expansion Valve	Thermal Expansion Valve
Drain Connection Number/Size (in.)	1¼ NPT	1¼ NPT	1¼ NPT
<b>Outdoor Fan</b>			
Type	Propeller	Propeller	Propeller
Number Used/Diameter (in.)	1/22	1/22	1/26
Drive Type/No. Speeds	Direct/1	Direct/1	Direct/1
cfm	3,600	4,050	5,130
Motor hp	0.25	0.33	0.40
Motor rpm	1,100	1,100	1,100



## General Data

**Table 3. General data - 3 to 5 tons - standard efficiency (continued)**

	3 Tons	4 Tons	5 Tons
	WSC036H3,4,W	WSC048H3,4,W	WSC060H3,4,W
<b>Indoor Fan</b>			
Type (Standard)	FC Centrifugal	FC Centrifugal	FC Centrifugal
Number Used/Diameter (in.)/Width (in.)	1/11x11	1/11x11	1/11x11
Drive Type/No. Speeds/rpm	Direct/5 <sup>(f)</sup>	Direct/5 <sup>(f)</sup>	Direct/5 <sup>(f)</sup>
Motor hp (standard/oversized)	0.75/1.5	1.0/1.5	1.0/1.5
Motor Frame Size (standard/oversized)	48/48	48/48	48/48
<b>Filters<sup>(g)</sup></b>			
Type Furnished	Throwaway	Throwaway	Throwaway
Number Size Recommended	(2) 20x35x2	(2) 20x35x2	(4) 16x25x2
<b>Refrigerant Charge<sup>(h)</sup></b>			
Pounds of R-410A	7.7	9.3	11.5

- (a) Cooling performance is rated at 95°F ambient, 80°F entering dry bulb, 67°F entering wet bulb. Gross capacity does not include the effect of fan motor heat. AHRI capacity is net and includes the effect of fan motor heat. Units are suitable for operation to ±20% of nominal cfm. Units are certified in accordance with the Unitary Air-Conditioner Equipment certification program, which is based on AHRI Standard 210/240.
- (b) EER and/or SEER are rated at AHRI conditions and in accordance with DOE test procedures.
- (c) EER2 and SEER2 is rated at AHRI conditions and calculated in accordance with AHRI Standard 210/240-2023. Airflow and net cooling capacity not shown.
- (d) Heating performance is rated at 47°F ambient with 43°F wet bulb, 70°F entering dry bulb, 60°F entering wet bulb. High temp. Btuh rating includes the effect of fan motor heat. Units are suitable for operation to ±20% of nominal cfm. Units are certified in accordance with the Unitary Air-Conditioner Equipment certification program, which is based on AHRI Standard 210/240.
- (e) Outdoor sound rating shown is tested in accordance with AHRI Standard 270. For additional information reference the outdoor sound power level data in the performance section.
- (f) For multispeed direct drive rpm values, reference the direct drive, evaporator fan performance table.
- (g) Optional 2" MERV 8 and MERV 13 filters also available.
- (h) Refrigerant charge is an approximate value. For a more precise value, see unit nameplate and service instructions.

**Table 4. General data - 6 to 10 tons - standard efficiency**

	7.5 Tons	8.5 Tons	10 Tons
	WSC092H3,4,W	WSC102H3,4,W	WSC120H3,4,W
<b>Cooling Performance<sup>(a)</sup></b>			
Gross Cooling Capacity	95,300	103,200	118,100
EER <sup>(b)</sup>	11.3	11.0	11.0
Nominal cfm/AHRI Rated cfm	3,000/3,000	3,400/3,315	4,000/4,000
AHRI Net Cooling Capacity	93,000	100,000	115,000
IEER <sup>(c)</sup>	14.1 <sup>(d)</sup>	14.1 <sup>(d)</sup>	14.1 <sup>(d)</sup>
System Power (kW)	8.23	9.09	10.45
<b>Heating Performance<sup>(e)</sup></b>			
High Temp. Btuh Rating	88,000 <sup>(f)</sup>	92,000 <sup>(f)</sup>	106,000
System Power kW/COP	7.59/3.40	7.93/3.40	9.14/3.40
Low Temp. Btuh Rating	48,000	48,500	58,500
System Power kW/COP	6.25/2.25	6.77/2.10	7.62/2.25
<b>Compressor</b>			
Number/Type	1/Scroll (2 Stage)	1/Scroll (2 Stage)	1/Scroll (2 Stage)
<b>Sound</b>			
Outdoor Sound Rating (dB) <sup>(g)</sup>	86	85	86

**Table 4. General data - 6 to 10 tons - standard efficiency (continued)**

	7.5 Tons	8.5 Tons	10 Tons
	WSC092H3,4,W	WSC102H3,4,W	WSC120H3,4,W
<b>Outdoor Coil</b>			
Type	Lanced	Lanced	Lanced
Configuration	Full Face	Full Face	Full Face
Tube Size (in.)	0.3125	0.3125	0.3125
Face Area (sq. ft.)	19.83	23.34	23.34
Rows/FPI	3/16	3/16	3/16
Refrigerant Control	Thermal Expansion Valve	Thermal Expansion Valve	Thermal Expansion Valve
<b>Indoor Coil</b>			
Type	Lanced	Lanced	Lanced
Configuration	Full Face	Full Face	Full Face
Tube Size (in.)	0.3125	0.3125	0.3125
Face Area (sq. ft.)	12.36	12.36	12.36
Rows/FPI	3/16	4/16	4/16
Refrigerant Control	Thermal Expansion Valve	Thermal Expansion Valve	Thermal Expansion Valve
Drain Connection Number/Size (in.)	1¼ NPT	1¼ NPT	1¼ NPT
<b>Outdoor Fan</b>			
Type	Propeller	Propeller	Propeller
Number Used/Diameter (in.)	1/26	1/26	1/26
Drive Type/No. Speeds	Direct/1	Direct/1	Direct/1
cfm	6,200	6,200	6,200
Motor hp	0.70	0.70	0.70
Motor rpm	1,100	1,100	1,100
<b>Indoor Fan</b>			
Type	FC Centrifugal <sup>(h)</sup>	FC Centrifugal <sup>(h)</sup>	BC Plenum
Number Used/Diameter (in.)/Width (in.)	1/15 x 15 <sup>(i)</sup>	1/15 x 15 <sup>(i)</sup>	1/19.7x15
Drive Type/No. Speeds/rpm	Belt/ Variable/1,750 <sup>(j)</sup>	Belt/ Variable/1,750 <sup>(j)</sup>	Direct/Variable <sup>(k)</sup>
Motor hp (Standard/Oversized)	1.0/3.0 <sup>(l)</sup>	2.0/3.0 <sup>(l)</sup>	2.75/—
Motor Frame Size (Standard/Oversized)	56/56	56/56	—/—
<b>Filters<sup>(m)</sup></b>			
Type Furnished	Throwaway	Throwaway	Throwaway
Number Size Recommended	(4) 20x25x2	(4) 20x25x2	(4) 20x25x2
<b>Refrigerant Charge<sup>(n)</sup></b>			
Pounds of R-410A	14.6	18.0	16.3

- (a) Cooling performance is rated at 95°F ambient, 80°F entering dry bulb, 67°F entering wet bulb. Gross capacity does not include the effect of fan motor heat. AHRI capacity is net and includes the effect of fan motor heat. Units are suitable for operation to ±20% of nominal cfm. Units are certified in accordance with the Unitary Air-Conditioner Equipment certification program, which is based on ARI Standard 340/360.
- (b) EER and/or SEER are rated at AHRI conditions and in accordance with DOE test procedures.
- (c) Integrated Efficiency Ratio (IEER) is rated in accordance with AHRI Standard 340/360. The IEER rating requires that the unit efficiency be determined at 100%, 75%, 50% and 25% load (net capacity) at the specified in AHRI Standard.
- (d) 14.6 IEER for SZVAV and Title 24 2-speed fan option.
- (e) Heating performance is rated at 47°F ambient with 43°F wet bulb, 70°F entering dry bulb, 60°F entering wet bulb. High temp. Btu/h Rating includes the effect of fan motor heat. Units are suitable for operation to ±20% of nominal cfm. Units are certified in accordance with the Unitary Air-Conditioner Equipment certification program, which is based on AHRI Standard 340/360.
- (f) For SZVAV/Title 24 option, 8.5 tons high temp. Btu/h rating = 89,000, 7.5 Tons high temp. Btu/h rating = 87,000.
- (g) Outdoor sound rating shown is tested in accordance with AHRI Standard 270-2015. For additional information reference the outdoor sound power level data in the performance section.
- (h) For SZVAV/Title 24 option, backward airfoil plenum.
- (i) For SZVAV/Title 24 option, 1/19.7X15.
- (j) For SZVAV/Title 24 option, direct/variable.
- (k) For multispeed direct drive rpm values, reference the direct drive, evaporator fan performance table.
- (l) For SZVAV/Title 24 option, 2.75.



## General Data

(m) Optional 2" MERV 8 and MERV 13 filters also available.

(n) Refrigerant charge is an approximate value. For a more precise value, see unit nameplate and service instructions.

**Table 5. General data - 3 to 5 tons - high efficiency**

	<b>3 Tons</b>	<b>4 Tons</b>	<b>5 Tons</b>
	<b>WHC036H3,4,W</b>	<b>WHC048H3,4,W</b>	<b>WHC060H3,4,W</b>
<b>Cooling Performance<sup>(a)</sup></b>			
Gross Cooling Capacity-High Stage	36,400	48,750	61,000
EER/SEER <sup>(b)</sup>	12.5/16.0	13.0/16.5	3=13.0/16.4 4,W=12.9/16.2
EER2/SEER2 <sup>(c)</sup>	12.5/15.6	12.5/16.1	12.5/16.1
Nominal cfm-High Stage/AHRI Rated cfm	1,200/1,200	1,600/1,680	2,000/2,000
Nominal cfm-Low Stage/AHRI Rated cfm	840	1,120	1,400
AHRI Net Cooling Capacity-High Stage	36,000	48,000	60,000
System Power-High Stage (kW)	2.88	3.69	4.62
<b>Heating Performance<sup>(d)</sup></b>			
High Temp. Btuh Rating-High Stage	32,200	44,000	57,000
System Power kW/COP-High Stage	2.62/3.60	3.58/3.60	4.64/3.60
System Power kW/COP2	2.71/3.50	3.53/3.60	4.41/3.60
Low Temp. Btuh Rating-High Stage	21,400	24,000	34,400
System Power kW/COP-High Stage	2.73/2.30	3.06/2.30	4.38/2.30
System Power kW/COP2	2.45/2.10	3.18/2.30	3.98/2.30
HSPF (Btu/Watts-hr)	8.80	8.80	9.00
HSPF2	8.00	8.40	8.50
<b>Compressor</b>			
Number/Type	1/Scroll (2-stage)	1/Scroll (2-stage)	1/Scroll (2-stage)
<b>Sound</b>			
Outdoor Sound Rating (dB) <sup>(e)</sup>	81	87	87
<b>Outdoor Coil</b>			
Type	Lanced	Lanced	Lanced
Tube Size (in.)	0.3125	0.3125	0.3125
Face Area (sq. ft.)	12.33	17.00	17.00
Rows/FPI	3/16	3/16	3/16
Refrigerant Control	Thermal Expansion Valve	Thermal Expansion Valve	Thermal Expansion Valve
<b>Indoor Coil</b>			
Type	Lanced	Lanced	Lanced
Tube Size (in.)	0.3125	0.3125	0.3125
Face Area (sq. ft.)	8.74	9.27	9.27
Rows/FPI	3/16	3/16	3/16
Refrigerant Control	Thermal Expansion Valve	Thermal Expansion Valve	Thermal Expansion Valve
Drain Connection Number/Size (in.)	1¼ NPT	1¼ NPT	1¼ NPT
<b>Outdoor Fan</b>			
Type	Propeller	Propeller	Propeller
Number Used/Diameter (in.)	1/22	1/26	1/26
Drive Type/No. Speeds	Direct/1	Direct/1	Direct/1
cfm	3,600	5,130	5,130
Motor hp	0.25	0.40	0.40
Motor rpm	1,100	1,100	1,100

**Table 5. General data - 3 to 5 tons - high efficiency (continued)**

	3 Tons	4 Tons	5 Tons
	WHC036H3,4,W	WHC048H3,4,W	WHC060H3,4,W
<b>Indoor Fan</b>			
Type (Standard)	FC Centrifugal	FC Centrifugal	FC Centrifugal
Number Used/Diameter (in.)/Width (in.)	1/11x11	1/11x11	1/11x11
Drive Type/No. Speeds/rpm	Direct/Variable	Direct/Variable	Direct/Variable
Motor hp (standard/oversized)	0.75/1.5	1.0/1.5	1.0/1.5
Motor Frame Size (standard/oversized)	48/48	48/48	48/48
<b>Filters<sup>(f)</sup></b>			
Type Furnished	Throwaway	Throwaway	Throwaway
Number Size Recommended	(2) 20x35x2	(4) 16x25x2	(4) 16x25x2
<b>Refrigerant Charge<sup>(g)</sup></b>			
Pounds of R-410A	8.8	10.8	10.8

- (a) Cooling performance is rated at 95°F ambient, 80°F entering dry bulb, 67°F entering wet bulb. Gross capacity does not include the effect of fan motor heat. AHRI capacity is net and includes the effect of fan motor heat. Units are suitable for operation to ±20% of nominal cfm. Units are certified in accordance with the Unitary Air-Conditioner Equipment certification program, which is based on AHRI Standard 210/240.
- (b) EER and/or SEER are rated at AHRI conditions and in accordance with DOE test procedures.
- (c) EER2 and SEER2 is rated at AHRI conditions and calculated in accordance with AHRI Standard 210/240-2023. Airflow and net cooling capacity not shown.
- (d) Heating performance is rated at 47°F ambient with 43°F wet bulb, 70°F entering dry bulb, 60°F entering wet bulb. High temp. Btuh rating includes the effect of fan motor heat. Units are suitable for operation to ±20% of nominal cfm. Units are certified in accordance with the Unitary Air-Conditioner Equipment certification program, which is based on AHRI Standard 210/240.
- (e) Outdoor sound rating shown is tested in accordance with AHRI Standard 270. For additional information reference the outdoor sound power level data in the performance section.
- (f) Optional 2" MERV 8 and MERV 13 filters also available.
- (g) Refrigerant charge is an approximate value. For a more precise value, see unit nameplate and service instructions.

**Table 6. General data - 6 to 10 tons - high efficiency**

	6 Tons	7.5 Tons	8.5 Tons	10 Tons
	WHC074H3,4,W	WHC092H3,4,W	WHC102H3,4,W	WHC120H3,4,W
<b>Cooling Performance<sup>(a)</sup></b>				
Gross Cooling Capacity - High Stage	78,900	96,200	105,900	123,600
EER <sup>(b)</sup>	12.1	11.8	3,4 = 12.0 / W = 11.8	11.5
Nominal CFM-High Stage / ARI Rated CFM	2,400 / 2,400	3,000 / 3,000	3,400 / 3,400	4,000 / 4,000
Nominal CFM-Low Stage / ARI Rated CFM	1,560	1,950	2,210	2,600
ARI Net Cooling Capacity - High Stage	78,000	95,000	104,000	121,000
IEER <sup>(c)</sup>	15.5 <sup>(d)</sup>	15.5 <sup>(d)</sup>	15.5 <sup>(d)</sup>	15.5 <sup>(d)</sup>
System Power - High Stage (kW)	6.45	8.05	8.67	10.52
<b>Heating Performance<sup>(e)</sup></b>				
High Temp. Btuh Rating - High Stage	75,000	87,000	93,000	118,000
System Power kW/COP - High Stage	6.28 / 3,4 = 3.50 6.32 / W = 3.48	7.29 / 3,4 = 3.50 7.33 / W = 3.48	7.51 / 3,4 = 3.63 7.55 / W = 3.61	9.53 / 3,4 = 3.63 9.58 / W = 3.61
Low Temp. Btuh Rating - High Stage	40,000	49,000	57,000	61,000
System Power kW/COP - High Stage	5.21 / 2.25	6.38 / 2.25	7.42 / 2.25	7.95 / 2.25
<b>Compressor</b>				
Number/Type	2 / Scroll	2 / Scroll	2 / Scroll	2 / Scroll
<b>Sound</b>				
Outdoor Sound Rating (dB) <sup>(f)</sup>	86	86	85	85



## General Data

**Table 6. General data - 6 to 10 tons - high efficiency (continued)**

	6 Tons	7.5 Tons	8.5 Tons	10 Tons
	WHC074H3,4,W	WHC092H3,4,W	WHC102H3,4,W	WHC120H3,4,W
<b>Outdoor Coil</b>				
Type	Lanced	Lanced	Lanced	Lanced
Configuration	Full Face	Full Face	Full Face	Full Face
Tube Size (in.)	0.3125	0.3125	0.3125	0.3125
Face Area (sq. ft.)	19.83	19.83	23.34	25.56
Rows/FPI	3 / 16	3 / 16	3 / 16	4 / 16
Refrigerant Control	Thermal Expansion Valve	Thermal Expansion Valve	Thermal Expansion Valve	Thermal Expansion Valve
<b>Indoor Coil</b>				
Type	Lanced	Lanced	Lanced	Lanced
Configuration	Full Face	Full Face	Full Face	Full Face
Tube Size (in.)	0.3125	0.3125	0.3125	0.3125
Face Area (sq. ft.)	12.36	12.36	12.36	16.59
Rows/FPI	3 / 16	3 / 16	4 / 16	4 / 16
Refrigerant Control	Thermal Expansion Valve	Thermal Expansion Valve	Thermal Expansion Valve	Thermal Expansion Valve
Drain Connection Number/Size (in.)	1¼ NPT	1¼ NPT	1¼ NPT	1¼ NPT
<b>Outdoor Fan</b>				
Type	Propeller	Propeller	Propeller	Propeller
Number Used/Diameter (in.)	1 / 26	1 / 26	1 / 26	1 / 30
Drive Type/No. Speeds	Direct / 1	Direct / 1	Direct / 1	Direct / 1
cfm	6200	6200	6200	6900
Motor hp	0.70	0.70	0.70	0.75
Motor rpm	1,100	1,100	1,100	1,100
<b>Indoor Fan</b>				
Type (Standard)	BC Plenum	BC Plenum	BC Plenum	BC Plenum
Number Used/Diameter (in.)/Width (in.)	1 / 19.7x15	1 / 19.7x15	1 / 19.7x15	1 / 19.7x15
Drive Type/No. Speeds/rpm	Direct/Variable <sup>(g)</sup>	Direct/Variable <sup>(g)</sup>	Direct/Variable <sup>(g)</sup>	Direct/Variable <sup>(g)</sup>
Motor hp (Standard/Oversized)	2.75 / -	2.75 / -	2.75 / -	2.75 / -
Motor Frame Size (Standard/Oversized)	- / -	- / -	- / -	- / -
<b>Filters<sup>(h)</sup></b>				
Type Furnished	Throwaway	Throwaway	Throwaway	Throwaway
Number Size Recommended	(4) 20x25x2	(4) 20x25x2	(4) 20x25x2	(3) 20x25x2 (2) 20x30x2
<b>Refrigerant Charge<sup>(i)</sup></b>				
Pounds of R-410A	14.5	14.2	17.0	23.9

(a) Cooling performance is rated at 95°F ambient, 80°F entering dry bulb, 67°F entering wet bulb. Gross capacity does not include the effect of fan motor heat. AHRI capacity is net and includes the effect of fan motor heat. Units are suitable for operation to ±20% of nominal cfm. Units are certified in accordance with the Unitary Air-Conditioner Equipment certification program, which is based on ARI Standard 340/360.

(b) EER and/or SEER are rated at AHRI conditions and in accordance with DOE test procedures.

(c) Integrated Efficiency Ratio (IEER) is rated in accordance with AHRI Standard 340/360. The IEER rating requires that the unit efficiency be determined at 100%, 75%, 50% and 25% load (net capacity) at the specified in AHRI Standard.

(d) 16.5 IEER for SZ/MZVAV option, 16.0 IEER for Title24 2 speed fan option.

(e) Heating performance is rated at 47°F ambient with 43°F wet bulb, 70°F entering dry bulb, 60°F entering wet bulb. High temp. Btu/h Rating includes the effect of fan motor heat. Units are suitable for operation to ±20% of nominal cfm. Units are certified in accordance with the Unitary Air-Conditioner Equipment certification program, which is based on AHRI Standard 340/360.

(f) Outdoor sound rating shown is tested in accordance with AHRI Standard 270-2015. For additional information reference the outdoor sound power level data in the performance section.

(g) For multispeed direct drive rpm values, reference the direct drive, evaporator fan performance tables.

(h) Optional 2" MERV 8 and MERV 13 filters also available.

(i) Refrigerant charge is an approximate value. For a more precise value, see unit nameplate and service instructions.

**Table 7. General data - 3 to 5 tons - dual fuel efficiency**

	<b>3 Tons</b>	<b>4 Tons</b>	<b>5 Tons</b>
	<b>DHC036H3,4,W</b>	<b>DHC048H3,4,W</b>	<b>DHC060H3,4,W</b>
<b>Cooling Performance<sup>(a)</sup></b>			
Gross Cooling Capacity-High Stage	36,400	48,750	61,000
EER/SEER <sup>(b)</sup>	3=12.5/15.7 4,W=12.5/15.6	13.0/16.5	3=12.8/16.2 4,W=12.8/16.0
Nominal cfm-High Stage/AHRI Rated cfm	1,200/1,200	1,600/1,680	2,000/2,000
Nominal cfm-Low Stage/AHRI Rated cfm	840	1,120	1,400
AHRI Net Cooling Capacity-High Stage	36,000	48,000	60,000
System Power-High Stage (kW)	2.88	3.69	4.69
<b>Heating Performance<sup>(c)</sup></b>			
High Temp. Btuh Rating-High Stage	32,200	44,000	57,000
System Power kW/COP-High Stage	2.62/3.60	3.58/3.60	4.64/3.60
Low Temp. Btuh Rating-High Stage	21,400	24,000	34,400
System Power kW/COP-High Stage	2.73/2.30	3.06/2.30	4.38/2.30
HSPF (Btu/Watts-hr)	8.80	8.80	8.90
<b>Compressor</b>			
Number/Type	1/Scroll (2-stage)	1/Scroll (2-stage)	1/Scroll (2-stage)
<b>Sound</b>			
Outdoor Sound Rating (dB) <sup>(d)</sup>	81	87	87
<b>Outdoor Coil</b>			
Type	Lanced	Lanced	Lanced
Tube Size (in.)	0.3125	0.3125	0.3125
Face Area (sq. ft.)	12.33	17.00	17.00
Rows/FPI	3/16	3/16	3/16
Refrigerant Control	Thermal Expansion Valve	Thermal Expansion Valve	Thermal Expansion Valve
<b>Indoor Coil</b>			
Type	Lanced	Lanced	Lanced
Tube Size (in.)	0.3125	0.3125	0.3125
Face Area (sq. ft.)	8.74	9.27	9.27
Rows/FPI	3/16	3/16	3/16
Refrigerant Control	Thermal Expansion Valve	Thermal Expansion Valve	Thermal Expansion Valve
Drain Connection Number/Size (in.)	1½ NPT	1½ NPT	1½ NPT
<b>Outdoor Fan</b>			
Type	Propeller	Propeller	Propeller
Number Used/Diameter (in.)	1/22	1/26	1/26
Drive Type/No. Speeds	Direct/1	Direct/1	Direct/1
cfm	3,600	5,130	5,130
Motor hp	0.25	0.40	0.40
Motor rpm	1,100	1,100	1,100
<b>Indoor Fan</b>			
Type (Standard)	FC Centrifugal	FC Centrifugal	FC Centrifugal
Number Used/Diameter (in.)/Width (in.)	1/11x11	1/11x11	1/11x11
Drive Type/No. Speeds/rpm	Direct/Variable	Direct/Variable	Direct/Variable
Motor hp (standard)	0.75	1.0	1.0
Motor Frame Size (standard)	48	48	48



## General Data

**Table 7. General data - 3 to 5 tons - dual fuel efficiency (continued)**

	3 Tons	4 Tons	5 Tons
	DHC036H3,4,W	DHC048H3,4,W	DHC060H3,4,W
<b>Filters<sup>(e)</sup></b>			
Type Furnished	Throwaway	Throwaway	Throwaway
Number Size Recommended	(2) 20x35x2	(4) 16x25x2	(4) 16x25x2
<b>Refrigerant Charge<sup>(f)</sup></b>			
Pounds of R-410A	8.8	10.8	10.8
<b>Gas Heating Performance (Dual Fuel Only)<sup>(g)</sup></b>			
<b>Gas Heating Input (2nd stage/1st stage)</b>			
Low Heat Input (Btu)	60,000/42,000	60,000/42,000	60,000/42,000
Mid Heat Input (Btu)	80,000/56,000	100,000/70,000	100,000/72,000
High Heat Input (Btu)	100,000/70,000	130,000/91,000	150,000/105,000
<b>Gas Heating Output (2nd stage/1st stage)</b>			
Low Heat Output (Btu)	48,600/34,020	48,600/34,020	48,600/34,020
Mid Heat Output (Btu)	64,800/45,360	81,000/56,700	81,000/58,320
High Heat Output (Btu)	81,000/56,700	105,300/73,710	121,500/85,050
<b>Steady State Efficiency %</b>	81%	81%	81%
<b>No. Burners</b>			
Low Heat Output (Btu)	2	2	2
Mid Heat Output (Btu)	2	3	3
High Heat Output (Btu)	3	3	4
<b>No. Stages</b>			
Low Heat Input (Btu)	2	2	2
Mid Heat Input (Btu)	2	2	2
High Heat Input (Btu)	2	2	2
<b>Gas Supply Line Pressure</b>			
Natural (minimum/maximum)	4.5/14.0	4.5/14.0	4.5/14.0
LP (minimum/maximum)	N/A	N/A	N/A
<b>Gas Connection Pipe Size (in.)</b>			
Low Heat	1/2	1/2	1/2
Mid Heat	1/2	1/2	1/2
High Heat	1/2	3/4	3/4

- (a) Cooling performance is rated at 95°F ambient, 80°F entering dry bulb, 67°F entering wet bulb. Gross capacity does not include the effect of fan motor heat. AHRI capacity is net and includes the effect of fan motor heat. Units are suitable for operation to ±20% of nominal cfm. Units are certified in accordance with the Unitary Air-Conditioner Equipment certification program, which is based on AHRI Standard 210/240.
- (b) EER and/or SEER are rated at AHRI conditions and in accordance with DOE test procedures.
- (c) Heating performance is rated at 47°F ambient with 43°F wet bulb, 70°F entering dry bulb, 60°F entering wet bulb. High temp. Btuh rating includes the effect of fan motor heat. Units are suitable for operation to ±20% of nominal cfm. Units are certified in accordance with the Unitary Air-Conditioner Equipment certification program, which is based on AHRI Standard 210/240.
- (d) Outdoor sound rating shown is tested in accordance with AHRI Standard 270. For additional information reference the outdoor sound power level data in the performance section.
- (e) Optional 2" MERV 8 and MERV 13 filters also available.
- (f) Refrigerant charge is an approximate value. For a more precise value, see unit nameplate and service instructions.
- (g) Heating performance limit settings and rating data were established and approved under laboratory test conditions using American National Standards Institute standards. Ratings shown are for elevations up to 2000 feet. For elevations above 2000 feet, ratings should be reduced at the rate of 4% for each 1000 feet above sea level. Applicable to dual fuel units only.



**Table 8. General data - 6 to 10 tons - dual fuel efficiency**

	<b>6 Tons</b>	<b>7.5 Tons</b>	<b>8.5 Tons</b>	<b>10 Tons</b>
	<b>DHC074H3,4,W</b>	<b>DHC092H3,4,W</b>	<b>DHC102H3,4,W</b>	<b>DHC120H3,4,W</b>
<b>Cooling Performance<sup>(a)</sup></b>				
Gross Cooling Capacity - High Stage	78,900	96,200	105,900	123,600
EER <sup>(b)</sup>	12.1	11.8	3,4 = 12.0 / W = 11.8	11.5
Nominal CFM-High Stage / ARI Rated CFM	2,400 / 2,400	3,000 / 3,000	3,400 / 3,400	4,000 / 4,000
Nominal CFM-Low Stage / ARI Rated CFM	1,560	1,950	2,210	2,600
ARI Net Cooling Capacity - High Stage	78,000	95,000	104,000	121,000
IEER <sup>(c)</sup>	15.5 <sup>(d)</sup>	15.5 <sup>(d)</sup>	15.5 <sup>(d)</sup>	15.5 <sup>(d)</sup>
System Power - High Stage (kW)	6.45	8.05	8.67	10.52
<b>Heating Performance<sup>(e)</sup></b>				
High Temp. Btuh Rating - High Stage	75,000	87,000	93,000	118,000
System Power kW/COP - High Stage	6.28 / 3,4 = 3.50 6.32 / W = 3.48	7.29 / 3,4 = 3.50 7.33 / W = 3.48	7.51 / 3,4 = 3.63 7.55 / W = 3.61	9.53 / 3,4 = 3.63 9.58 / W = 3.61
Low Temp. Btuh Rating - High Stage	40,000	49,000	57,000	61,000
System Power kW/COP - High Stage	5.21 / 2.25	6.38 / 2.25	7.42 / 2.25	7.95 / 2.25
<b>Compressor</b>				
Number/Type	2 / Scroll	2 / Scroll	2 / Scroll	2 / Scroll
<b>Sound</b>				
Outdoor Sound Rating (dB) <sup>(f)</sup>	86	86	85	85
<b>Outdoor Coil</b>				
Type	Lanced	Lanced	Lanced	Lanced
Configuration	Full Face	Full Face	Full Face	Full Face
Tube Size (in.)	0.3125	0.3125	0.3125	0.3125
Face Area (sq. ft.)	19.83	19.83	23.34	25.56
Rows/FPI	3 / 16	3 / 16	3 / 16	4 / 16
Refrigerant Control	Thermal Expansion Valve	Thermal Expansion Valve	Thermal Expansion Valve	Thermal Expansion Valve
<b>Indoor Coil</b>				
Type	Lanced	Lanced	Lanced	Lanced
Configuration	Full Face	Full Face	Full Face	Full Face
Tube Size (in.)	0.3125	0.3125	0.3125	0.3125
Face Area (sq. ft.)	12.36	12.36	12.36	16.59
Rows/FPI	3 / 16	3 / 16	4 / 16	4 / 16
Refrigerant Control	Thermal Expansion Valve	Thermal Expansion Valve	Thermal Expansion Valve	Thermal Expansion Valve
Drain Connection Number/Size (in.)	1¼ NPT	1¼ NPT	1¼ NPT	1¼ NPT
<b>Outdoor Fan</b>				
Type	Propeller	Propeller	Propeller	Propeller
Number Used/Diameter (in.)	1 / 26	1 / 26	1 / 26	1 / 30
Drive Type/No. Speeds	Direct / 1	Direct / 1	Direct / 1	Direct / 1
cfm	6200	6200	6200	6900
Motor hp	0.70	0.70	0.70	0.75
Motor rpm	1,100	1,100	1,100	1,100



## General Data

**Table 8. General data - 6 to 10 tons - dual fuel efficiency (continued)**

	6 Tons			7.5 Tons			8.5 Tons			10 Tons		
	DHC074H3,4,W			DHC092H3,4,W			DHC102H3,4,W			DHC120H3,4,W		
<b>Indoor Fan</b>												
Type (Standard)	BC Plenum			BC Plenum			BC Plenum			BC Plenum		
Number Used/Diameter (in.)/Width (in.)	1 / 19.7x15			1 / 19.7x15			1 / 19.7x15			1 / 19.7x15		
Drive Type/No. Speeds/rpm	Direct/Variable <sup>(g)</sup>			Direct/Variable <sup>(g)</sup>			Direct/Variable <sup>(g)</sup>			Direct/Variable <sup>(g)</sup>		
Motor hp (Standard/Oversized)	2.75 / -			2.75 / -			2.75 / -			2.75 / -		
Motor Frame Size (Standard/Oversized)	- / -			- / -			- / -			- / -		
<b>Filters<sup>(h)</sup></b>												
Type Furnished	Throwaway			Throwaway			Throwaway			Throwaway		
Number Size Recommended	(4) 20x25x2			(4) 20x25x2			(4) 20x25x2			(3) 20x25x2 (2) 20x30x2		
<b>Refrigerant Charge<sup>(i)</sup></b>												
Pounds of R-410A	14.5			14.2			17.0			23.9		

- (a) Cooling performance is rated at 95°F ambient, 80°F entering dry bulb, 67°F entering wet bulb. Gross capacity does not include the effect of fan motor heat. AHRI capacity is net and includes the effect of fan motor heat. Units are suitable for operation to ±20% of nominal cfm. Units are certified in accordance with the Unitary Air-Conditioner Equipment certification program, which is based on ARI Standard 340/360.
- (b) EER and/or SEER are rated at AHRI conditions and in accordance with DOE test procedures.
- (c) Integrated Efficiency Ratio (IEER) is rated in accordance with AHRI Standard 340/360. The IEER rating requires that the unit efficiency be determined at 100%, 75%, 50% and 25% load (net capacity) at the specified in AHRI Standard.
- (d) 16.5 IEER for SZ/MZVAV option, 16.0 IEER for Title24 2 speed fan option.
- (e) Heating performance is rated at 47°F ambient with 43°F wet bulb, 70°F entering dry bulb, 60°F entering wet bulb. High temp. Btu/h Rating includes the effect of fan motor heat. Units are suitable for operation to ±20% of nominal cfm. Units are certified in accordance with the Unitary Air-Conditioner Equipment certification program, which is based on AHRI Standard 340/360.
- (f) Outdoor sound rating shown is tested in accordance with AHRI Standard 270-2015. For additional information reference the outdoor sound power level data in the performance section.
- (g) For multispeed direct drive rpm values, reference the direct drive, evaporator fan performance tables.
- (h) Optional 2" MERV 8 and MERV 13 filters also available.
- (i) Refrigerant charge is an approximate value. For a more precise value, see unit nameplate and service instructions.

**Table 9. Heating Performance - 6 to 10 tons - dual fuel efficiency (gas/electric only)**

	6 Tons			7.5 Tons			8.5 Tons			10 Tons		
	DHC074H3,4,W			DHC092H3,4,W			DHC102H3,4,W			DHC120H3,4,W		
Heating Models	Low	Medium	High	Low	Medium	High	Low	Medium	High	Low	Medium	High
Heating Input (Btu)	80,000	120,000	150,000 / 105,000	120,000	150,000 / 105,000	200,000 / 140,000	120,000	150,000 / 105,000	200,000 / 140,000	150,000 / 105,000	200,000 / 140,000	250,000 / 175,000
Heating Output (Btu)	64,800	97,200	121,500 / 85,050	97,200	121,500 / 85,050	162,000 / 113,400	97,200	121,500 / 85,050	162,000 / 113,400	121,500 / 85,050	162,000 / 113,400	202,500 / 141,750
Steady State Efficiency %	81			81			81			81		
No. Burners	3	3	3	3	3	5	3	3	5	3	4	5
No. Stages	1	1	2	1	2	2	1	2	2	2	2	2
Gas Supply Line Pressure												
Natural (minimum/maximum) "w.c.	4.5 / 14.0			4.5 / 14.0			4.5 / 14.0			4.5 / 14.0		
LP (minimum/maximum) "w.c.	11.0 / 14.0			11.0 / 14.0			11.0 / 14.0			11.0 / 14.0		
Gas Connection Pipe Size (in)	1/2	1/2	3/4	1/2	3/4	3/4	1/2	3/4	3/4	3/4	3/4	3/4

**Note:** Heating performance limit settings and rating data were established and approved under laboratory test conditions using American National Standards Institute standards. Ratings shown are for elevations up to 2000 feet. For elevations above 2000 feet, ratings should be reduced at the rate of 4% for each 1000 feet above sea level. Applicable to Gas/Electric units only.



# Gross Cooling Capacities

Table 10. Gross cooling capacities 3 tons standard efficiency - three phase WSC036H3,4,W

cfm	Ent DB (°F)	Ambient Temperature (°F)						Ambient Temperature (°F)						Ambient Temperature (°F)					
		85						95						105					
		Entering Wet Bulb (°F)						Entering Wet Bulb (°F)						Entering Wet Bulb (°F)					
		61		67		73		61		67		73		61		67		73	
		MBh	SHC	MBh	SHC	MBh	SHC	MBh	SHC	MBh	SHC	MBh	SHC	MBh	SHC	MBh	SHC	MBh	SHC
960	75	36.0	28.2	40.5	22.2	45.2	15.9	33.6	26.8	37.8	20.9	42.3	14.7	31.0	25.4	35.1	19.5	39.3	13.3
960	80	36.0	33.2	40.6	27.3	45.3	21.1	33.6	31.7	38.0	26.0	42.4	19.8	31.1	30.3	35.2	24.7	39.4	18.5
960	85	36.2	36.2	40.7	32.4	45.4	26.3	34.1	34.1	38.0	31.1	42.5	25.0	32.1	32.1	35.3	29.7	39.5	23.6
960	90	38.2	38.2	40.7	37.4	45.5	31.4	36.2	36.2	38.1	36.1	42.6	30.1	34.1	34.1	35.4	34.6	39.6	28.8
1080	75	36.8	30.0	41.4	23.3	46.1	16.2	34.3	28.6	38.6	21.9	43.0	14.9	31.6	27.2	35.7	20.5	39.8	13.5
1080	80	36.9	35.5	41.5	29.0	46.2	22.0	34.4	34.1	38.7	27.7	43.1	20.7	31.8	31.8	35.8	26.3	40.0	19.4
1080	85	37.8	37.8	41.6	34.8	46.3	27.8	35.7	35.7	38.8	33.4	43.3	26.5	33.5	33.5	35.9	32.0	40.1	25.1
1080	90	40.1	40.1	41.7	40.3	46.4	33.6	38.0	38.0	39.0	38.9	43.4	32.3	35.7	35.7	36.2	36.2	40.2	30.9
1200	75	37.5	31.9	42.1	24.3	46.8	16.5	34.8	30.4	39.2	22.9	43.6	15.1	32.1	28.8	36.1	21.5	40.3	13.7
1200	80	37.7	37.7	42.2	30.7	46.9	23.0	35.1	35.1	39.3	29.3	43.7	21.6	32.5	32.5	36.3	27.9	40.4	20.2
1200	85	39.4	39.4	42.3	37.1	47.0	29.4	37.1	37.1	39.5	35.7	43.9	28.0	34.8	34.8	36.5	34.3	40.6	26.6
1200	90	41.8	41.8	42.6	42.6	47.1	35.8	39.5	39.5	39.8	39.8	44.0	34.4	37.1	37.1	37.1	37.1	40.7	33.0
1320	75	38.1	33.7	42.7	25.4	47.3	16.8	35.3	32.2	39.6	23.9	44.0	15.4	32.4	30.4	36.5	22.5	40.6	13.9
1320	80	38.5	38.5	42.8	32.4	47.4	23.9	35.9	35.9	39.8	31.0	44.1	22.5	33.5	33.5	36.7	29.5	40.8	21.0
1320	85	40.8	40.8	43.0	39.4	47.6	30.9	38.4	38.4	40.0	37.7	44.3	29.5	35.9	35.9	36.9	36.2	40.9	28.1
1320	90	43.3	43.3	43.5	43.5	47.7	38.0	40.8	40.8	40.9	40.9	44.5	36.6	38.2	38.2	38.3	38.3	41.1	35.1
1440	75	38.6	35.5	43.1	26.4	47.8	17.0	35.7	33.7	40.0	24.9	44.3	15.6	32.8	32.1	36.8	23.4	40.8	14.1
1440	80	39.3	39.3	43.3	34.1	47.9	24.7	36.9	36.9	40.2	32.6	44.5	23.3	34.4	34.4	37.0	31.1	41.0	21.8
1440	85	42.0	42.0	43.5	41.5	48.1	32.5	39.5	39.5	40.5	40.0	44.7	31.0	36.8	36.8	37.4	37.4	41.2	29.6
1440	90	44.5	44.5	44.6	44.6	48.2	40.1	41.9	41.9	42.0	42.0	44.9	38.7	39.2	39.2	39.3	39.3	41.4	37.3
cfm	Ent DB (°F)	Ambient Temperature (°F)						Ambient Temperature (°F)											
		115						125											
		Entering Wet Bulb (°F)						Entering Wet Bulb (°F)											
		61		67		73		61		67		73							
		MBh	SHC	MBh	SHC	MBh	SHC	MBh	SHC	MBh	SHC	MBh	SHC						
960	75	28.4	24.0	32.2	18.2	36.1	12.0	25.7	22.6	29.3	16.8	32.8	10.6						
960	80	28.5	28.5	32.4	23.3	36.2	17.2	25.8	25.8	29.4	21.9	33.0	15.8						
960	85	29.9	29.9	32.4	28.4	36.4	22.3	27.7	27.7	29.5	26.9	33.1	20.9						
960	90	31.9	31.9	32.6	32.6	36.5	27.4	29.6	29.6	29.7	29.7	33.2	26.0						
1080	75	28.8	25.8	32.7	19.1	36.6	12.2	26.0	24.1	29.6	17.7	33.1	10.8						
1080	80	29.2	29.2	32.9	24.9	36.7	18.0	26.8	26.8	29.7	23.4	33.3	16.6						
1080	85	31.2	31.2	33.0	30.6	36.8	23.8	28.8	28.8	29.9	28.9	33.4	22.3						
1080	90	33.3	33.3	33.4	33.4	37.0	29.5	30.8	30.8	30.9	30.9	33.6	28.1						
1200	75	29.2	27.2	33.0	20.1	36.9	12.3	26.3	25.7	29.8	18.6	33.3	10.9						
1200	80	30.2	30.2	33.2	26.5	37.0	18.8	27.7	27.7	30.0	25.0	33.5	17.3						
1200	85	32.3	32.3	33.4	32.5	37.2	25.2	29.8	29.8	30.3	30.3	33.6	23.7						
1200	90	34.5	34.5	34.6	34.6	37.3	31.6	31.8	31.8	31.9	31.9	33.8	30.1						
1320	75	29.5	28.9	33.3	21.0	37.1	12.5	26.5	26.5	29.9	19.5	33.4	11.0						
1320	80	31.0	31.0	33.5	28.0	37.3	19.6	28.4	28.4	30.1	26.5	33.6	18.1						
1320	85	33.3	33.3	33.8	33.8	37.4	26.6	30.5	30.5	30.6	30.6	33.8	25.1						
1320	90	35.5	35.5	35.6	35.6	37.6	33.7	32.7	32.7	32.7	32.7	34.0	31.8						
1440	75	29.8	29.8	33.5	21.9	37.2	12.6	26.8	26.8	30.0	20.4	33.4	11.1						
1440	80	31.7	31.7	33.7	29.6	37.4	20.4	28.9	28.9	30.2	27.7	33.7	18.8						
1440	85	34.1	34.1	34.2	34.2	37.6	28.1	31.2	31.2	31.2	31.2	33.9	26.5						
1440	90	36.4	36.4	36.4	36.4	37.9	35.4	33.3	33.3	33.4	33.4	34.2	33.8						

**Notes:**

1. All capacities shown are gross and have not considered indoor fan heat. To obtain **NET** cooling capacity subtract indoor fan heat. For indoor fan heat formula, refer to appropriate airflow table notes.
2. MBh = Total Gross Capacity
3. SHC = Sensible Heat Capacity



## Gross Cooling Capacities

**Table 11. Gross cooling capacities 4 tons standard efficiency - three phase WSC048H3,4,W**

cfm	Ent DB (°F)	Ambient Temperature (°F)						Ambient Temperature (°F)						Ambient Temperature (°F)					
		85						95						105					
		Entering Wet Bulb (°F)						Entering Wet Bulb (°F)						Entering Wet Bulb (°F)					
		61		67		73		61		67		73		61		67		73	
		MBh	SHC	MBh	SHC	MBh	SHC	MBh	SHC	MBh	SHC	MBh	SHC	MBh	SHC	MBh	SHC		
1280	75	45.5	36.5	50.8	28.3	56.4	19.8	42.8	35.0	47.9	26.8	53.1	18.3	40.0	33.5	44.8	25.3	49.7	16.8
1280	80	45.9	43.3	51.0	35.2	56.6	26.8	43.3	41.7	48.1	33.7	53.3	25.3	40.6	40.2	45.0	32.2	49.9	23.8
1280	85	47.4	47.4	51.2	42.1	56.7	33.7	45.1	45.1	48.3	40.6	53.5	32.2	42.7	42.7	45.3	39.1	50.1	30.7
1280	90	50.1	50.1	51.7	48.8	56.9	40.6	47.8	47.8	48.9	47.3	53.7	39.1	45.3	45.3	45.9	45.7	50.4	37.6
1440	75	46.6	39.1	51.8	29.8	57.4	20.2	43.8	37.6	48.7	28.3	54.0	18.7	40.9	36.0	45.5	26.7	50.4	17.2
1440	80	47.3	46.7	52.0	37.5	57.5	28.0	44.6	44.6	49.0	36.0	54.2	26.5	41.8	41.8	45.8	34.5	50.7	25.0
1440	85	49.5	49.5	52.4	45.3	57.7	35.8	47.1	47.1	49.4	43.8	54.4	34.3	44.5	44.5	46.3	42.3	50.9	32.8
1440	90	52.4	52.4	53.2	52.9	58.0	43.6	49.9	49.9	50.3	50.3	54.7	42.1	47.2	47.2	47.3	47.3	51.2	40.5
1600	75	47.5	41.6	52.6	31.2	58.1	20.6	44.6	40.1	49.4	29.7	54.7	19.0	41.6	38.1	46.1	28.1	51.0	17.5
1600	80	48.5	48.5	52.9	39.8	58.3	29.2	45.8	45.8	49.8	38.3	54.9	27.7	43.2	43.2	46.5	36.7	51.3	26.2
1600	85	51.4	51.4	53.4	48.5	58.5	37.9	48.8	48.8	50.3	46.7	55.1	36.4	46.0	46.0	47.1	45.0	51.5	34.8
1600	90	54.4	54.4	54.6	54.6	58.9	46.6	51.7	51.7	51.8	51.8	55.6	45.1	48.9	48.9	49.0	49.0	52.0	43.5
1720	75	48.3	44.1	53.2	32.6	58.8	20.9	45.4	42.2	50.0	31.0	55.2	19.4	42.3	40.4	46.6	29.4	51.4	17.8
1720	80	49.8	49.8	53.6	42.1	59.0	30.5	47.2	47.2	50.4	40.6	55.5	28.9	44.4	44.4	47.0	39.0	51.7	27.3
1720	85	53.0	53.0	54.4	51.4	59.3	40.0	50.2	50.2	51.3	49.7	55.8	38.4	47.4	47.4	48.0	48.0	52.1	36.9
1720	90	56.1	56.1	56.2	56.2	59.8	49.6	53.3	53.3	53.4	53.4	56.3	48.0	50.3	50.3	50.4	50.4	52.7	46.4
1920	75	49.0	46.2	53.7	34.0	59.3	21.3	46.1	44.5	50.4	32.4	55.6	19.7	42.9	42.8	46.9	30.8	51.8	18.1
1920	80	51.1	51.1	54.3	44.4	59.5	31.7	48.4	48.4	51.0	42.8	55.9	30.1	45.5	45.5	47.5	41.2	52.1	28.5
1920	85	54.4	54.4	55.3	54.4	59.9	42.1	51.5	51.5	52.1	52.1	56.3	40.5	48.5	48.5	48.7	48.7	52.5	38.9
1920	90	57.6	57.6	57.7	57.7	60.5	52.5	54.7	54.7	54.8	54.8	57.0	51.0	51.5	51.5	51.6	51.6	53.2	48.9
cfm	Ent DB (°F)	Ambient Temperature (°F)						Ambient Temperature (°F)											
		115						125											
		Entering Wet Bulb (°F)						Entering Wet Bulb (°F)											
		61		67		73		61		67		73							
		MBh	SHC	MBh	SHC	MBh	SHC	MBh	SHC	MBh	SHC	MBh	SHC						
1280	75	37.0	31.9	41.5	23.7	46.1	15.4	33.9	30.2	38.0	22.0	42.2	13.6						
1280	80	37.8	37.8	41.7	30.6	46.4	22.2	34.9	34.9	38.2	28.9	42.5	20.6						
1280	85	40.1	40.1	42.1	37.5	46.6	29.1	37.3	37.3	38.6	35.5	42.7	27.5						
1280	90	42.6	42.6	42.9	42.9	46.8	36.0	39.7	39.7	39.8	39.8	43.0	34.4						
1440	75	37.8	34.0	42.1	25.1	46.7	15.6	34.5	32.3	38.5	23.4	42.7	13.9						
1440	80	39.1	39.1	42.4	32.8	47.0	23.4	36.2	36.2	38.8	31.1	43.0	21.7						
1440	85	41.7	41.7	42.9	40.3	47.2	31.2	38.7	38.7	39.4	38.5	43.2	29.5						
1440	90	44.4	44.4	44.5	44.5	47.6	39.0	41.3	41.3	41.3	41.3	43.6	37.3						
1600	75	38.5	36.4	42.6	26.4	47.2	15.9	35.2	34.5	38.9	24.7	43.0	14.2						
1600	80	40.4	40.4	43.0	35.1	47.5	24.5	37.3	37.3	39.3	33.3	43.4	22.8						
1600	85	43.1	43.1	43.8	43.3	47.7	33.2	39.9	39.9	40.2	40.2	43.7	31.5						
1600	90	45.9	45.9	45.9	45.9	48.2	41.9	42.6	42.6	42.6	42.6	44.2	40.2						
1720	75	39.1	38.7	43.0	27.8	47.5	16.2	35.7	35.7	39.2	26.0	43.3	14.4						
1720	80	41.4	41.4	43.5	37.3	47.8	25.7	38.2	38.2	39.7	35.1	43.6	24.0						
1720	85	44.3	44.3	44.5	44.5	48.2	35.2	41.0	41.0	41.0	41.0	44.0	33.5						
1720	90	47.1	47.1	47.2	47.2	48.8	44.8	43.6	43.6	43.7	43.7	44.7	42.4						
1920	75	39.7	39.7	43.3	29.1	47.8	16.4	36.2	36.2	39.4	27.3	43.5	14.7						
1920	80	42.4	42.4	43.9	39.0	48.1	26.8	39.0	39.0	40.1	37.1	43.8	25.1						
1920	85	45.3	45.3	45.4	45.4	48.6	37.3	41.8	41.8	41.9	41.9	44.3	35.5						
1920	90	48.2	48.2	48.3	48.3	49.4	47.1	44.5	44.5	44.6	44.6	45.2	45.2						

**Notes:**

1. All capacities shown are gross and have not considered indoor fan heat. To obtain **NET** cooling capacity subtract indoor fan heat. For indoor fan heat formula, refer to appropriate airflow table notes.
2. MBh = Total Gross Capacity
3. SHC = Sensible Heat Capacity

## Gross Cooling Capacities

**Table 12. Gross cooling capacities 5 tons standard efficiency - three phase WSC060H3,4,W**

cfm	Ent DB (°F)	Ambient Temperature (°F)						Ambient Temperature (°F)						Ambient Temperature (°F)					
		85						95						105					
		Entering Wet Bulb (°F)						Entering Wet Bulb (°F)						Entering Wet Bulb (°F)					
		61		67		73		61		67		73		61		67		73	
		MBh	SHC	MBh	SHC	MBh	SHC	MBh	SHC	MBh	SHC	MBh	SHC	MBh	SHC	MBh	SHC		
1600	75	56.3	46.5	63.0	35.9	70.1	24.9	52.8	44.7	59.1	34.1	65.7	23.1	49.0	42.7	54.9	32.2	61.2	21.2
1600	80	56.6	55.4	63.1	44.8	70.2	33.9	53.1	53.1	59.2	43.0	65.9	32.1	49.4	49.4	55.1	41.1	61.3	30.2
1600	85	58.0	58.0	63.3	53.7	70.3	42.9	55.0	55.0	59.4	51.9	66.0	41.1	51.9	51.9	55.3	50.0	61.5	39.2
1600	90	61.3	61.3	63.5	62.6	70.4	51.8	58.3	58.3	59.8	59.8	66.2	50.0	55.0	55.0	55.8	55.8	61.7	48.1
1800	75	57.5	49.7	64.2	37.8	71.3	25.4	53.7	47.8	60.0	35.9	66.7	23.5	49.8	45.8	55.7	33.9	61.9	21.6
1800	80	58.0	58.0	64.3	47.8	71.4	35.5	54.4	54.4	60.2	45.9	66.9	33.7	50.6	50.6	55.9	43.9	62.1	31.7
1800	85	60.5	60.5	64.5	57.8	71.5	45.6	57.3	57.3	60.5	55.9	67.1	43.8	53.9	53.9	56.2	54.0	62.3	41.8
1800	90	64.0	64.0	65.1	65.1	71.7	55.6	60.7	60.7	61.3	61.3	67.3	53.8	57.2	57.2	57.2	57.2	62.5	51.9
2000	75	58.4	52.9	65.1	39.6	72.2	25.9	54.5	50.9	60.8	37.6	67.5	24.0	50.5	48.6	56.3	35.6	62.5	22.0
2000	80	59.3	59.3	65.3	50.7	72.4	37.1	55.6	55.6	61.0	48.8	67.7	35.2	52.2	52.2	56.5	46.7	62.7	33.2
2000	85	62.6	62.6	65.6	61.8	72.5	48.3	59.2	59.2	61.4	59.9	67.9	46.4	55.6	55.6	57.0	57.0	62.9	44.4
2000	90	66.3	66.3	66.6	66.6	72.7	59.5	62.8	62.8	62.8	62.8	68.1	57.6	59.0	59.0	59.1	59.1	63.2	55.6
2200	75	59.2	56.0	65.9	41.4	73.0	26.3	55.2	54.0	61.4	39.3	68.1	24.3	51.0	51.0	56.7	37.3	63.0	22.3
2200	80	60.6	60.6	66.1	53.6	73.2	38.7	57.2	57.2	61.7	51.6	68.3	36.7	53.5	53.5	57.0	49.5	63.2	34.7
2200	85	64.5	64.5	66.5	65.9	73.4	51.0	60.9	60.9	62.3	62.3	68.6	49.0	57.1	57.1	57.8	57.8	63.4	47.0
2200	90	68.3	68.3	68.2	68.2	73.6	63.3	64.6	64.6	64.7	64.7	68.8	61.3	60.6	60.6	60.7	60.7	63.8	59.3
2400	75	59.9	59.2	66.5	43.1	73.7	26.8	55.8	55.8	61.9	41.1	68.6	24.7	51.5	51.5	57.1	38.9	63.4	22.6
2400	80	62.2	62.2	66.8	56.5	73.9	40.3	58.5	58.5	62.2	54.5	68.8	38.2	54.6	54.6	57.4	52.3	63.6	36.1
2400	85	66.2	66.2	67.4	67.4	74.1	53.7	62.4	62.4	63.1	63.1	69.1	51.7	58.3	58.3	58.5	58.5	63.8	49.6
2400	90	70.1	70.1	70.2	70.2	74.3	67.1	66.2	66.2	66.3	66.3	69.5	65.1	62.0	62.0	62.1	62.1	64.3	63.1

cfm	Ent DB (°F)	Ambient Temperature (°F)						Ambient Temperature (°F)					
		115						125					
		Entering Wet Bulb (°F)						Entering Wet Bulb (°F)					
		61		67		73		61		67		73	
		MBh	SHC	MBh	SHC	MBh	SHC	MBh	SHC	MBh	SHC		
1600	75	45.0	40.7	50.5	30.2	56.3	19.3	40.8	38.7	45.8	28.1	51.1	17.2
1600	80	45.6	45.6	50.7	39.1	56.5	28.3	41.9	41.9	46.0	37.0	51.3	26.2
1600	85	48.5	48.5	51.0	48.0	56.7	37.3	44.8	44.8	46.3	46.0	51.5	35.2
1600	90	51.5	51.5	51.7	51.7	56.8	46.2	47.7	47.7	47.8	47.8	51.7	44.2
1800	75	45.6	43.8	51.1	31.8	56.9	19.6	41.2	41.2	46.2	29.7	51.5	17.5
1800	80	47.1	47.1	51.3	41.9	57.1	29.7	43.3	43.3	46.4	39.8	51.7	27.6
1800	85	50.3	50.3	51.7	51.7	57.3	39.8	46.3	46.3	47.0	47.0	51.9	37.7
1800	90	53.4	53.4	53.5	53.5	57.5	49.9	49.3	49.3	49.4	49.4	52.2	47.8
2000	75	46.1	46.1	51.5	33.5	57.3	19.9	41.7	41.7	46.5	31.3	51.7	17.7
2000	80	48.4	48.4	51.8	44.7	57.5	31.2	44.4	44.4	46.7	42.5	51.9	29.0
2000	85	51.7	51.7	52.5	52.5	57.7	42.4	47.5	47.5	47.7	47.7	52.2	40.2
2000	90	55.0	55.0	55.1	55.1	58.0	53.6	50.7	50.7	50.7	50.7	52.6	51.4
2200	75	46.7	46.7	51.8	35.1	57.6	20.2	42.1	42.1	46.6	32.9	51.8	18.0
2200	80	49.5	49.5	52.1	47.4	57.8	32.6	45.3	45.3	47.0	45.2	52.1	30.4
2200	85	53.0	53.0	53.2	53.2	58.1	44.9	48.5	48.5	48.6	48.6	52.3	42.7
2200	90	56.4	56.4	56.5	56.5	58.5	57.3	51.8	51.8	51.8	51.8	52.9	52.9
2400	75	47.1	47.1	52.0	36.7	57.8	20.5	42.5	42.5	46.7	34.5	51.9	18.2
2400	80	50.5	50.5	52.4	50.2	58.1	34.0	46.0	46.0	47.2	47.2	52.2	31.7
2400	85	54.0	54.0	53.9	53.9	58.3	47.4	49.4	49.4	49.4	49.4	52.4	45.2
2400	90	57.5	57.5	57.6	57.6	59.0	59.0	52.7	52.7	52.7	52.7	53.3	53.3

**Notes:**

1. All capacities shown are gross and have not considered indoor fan heat. To obtain **NET** cooling capacity subtract indoor fan heat. For indoor fan heat formula, refer to appropriate airflow table notes.
2. MBh = Total Gross Capacity
3. SHC = Sensible Heat Capacity



## Gross Cooling Capacities

**Table 13. Gross cooling capacities 7.5 tons standard efficiency - three phase WSC092H3,4,W**

cfm	Ent DB (°F)	Ambient Temperature (°F)						Ambient Temperature (°F)						Ambient Temperature (°F)					
		85						95						105					
		Entering Wet Bulb (°F)						Entering Wet Bulb (°F)						Entering Wet Bulb (°F)					
		61		67		73		61		67		73		61		67		73	
		MBh	SHC	MBh	SHC	MBh	SHC	MBh	SHC	MBh	SHC	MBh	SHC	MBh	SHC	MBh	SHC		
2400	75	87.1	70.9	97.1	55.2	107.9	39.0	82.3	68.1	91.7	52.8	101.8	36.6	77.2	65.5	86.0	50.3	95.4	34.1
2400	80	88.0	83.4	97.4	68.3	108.1	52.2	83.3	81.0	92.0	65.9	102.1	49.8	78.4	78.4	86.4	63.4	95.8	47.3
2400	85	91.3	91.3	97.8	81.4	108.4	65.3	87.2	87.2	92.5	78.5	102.4	62.9	82.8	82.8	86.9	75.9	96.1	60.4
2400	90	96.5	96.5	98.8	93.9	108.6	78.4	92.3	92.2	93.6	91.4	102.7	76.0	87.7	87.7	88.2	88.2	96.4	73.5
2700	75	89.2	75.2	99.1	58.0	109.8	39.8	84.2	72.7	93.4	55.5	103.5	37.3	78.8	70.0	87.5	53.0	96.8	34.8
2700	80	90.5	89.8	99.4	72.7	110.1	54.6	85.7	85.7	93.8	70.3	103.8	52.1	81.1	81.1	87.9	67.7	97.2	49.6
2700	85	95.3	95.3	100.1	86.9	110.4	69.4	90.9	90.9	94.6	84.3	104.2	66.9	86.2	86.2	88.8	81.6	97.6	64.4
2700	90	100.8	100.8	101.6	101.5	110.8	84.1	96.2	96.2	96.4	96.4	104.6	81.7	91.3	91.3	91.5	91.5	98.1	79.2
3000	75	90.9	79.8	100.7	60.7	111.3	40.5	85.7	77.2	94.8	58.2	104.8	38.0	80.2	74.4	88.7	55.6	97.9	35.4
3000	80	93.0	93.0	101.1	77.1	111.7	57.0	88.5	88.5	95.3	74.6	105.2	54.5	83.7	83.7	89.2	71.3	98.4	51.9
3000	85	98.7	98.7	102.1	92.7	112.1	73.4	94.1	94.1	96.4	90.1	105.6	70.9	89.0	89.0	90.4	87.4	98.8	68.3
3000	90	104.5	104.5	104.6	104.6	112.6	89.8	99.6	99.6	99.8	99.8	106.3	86.6	94.4	94.4	94.5	94.5	99.6	83.9
3300	75	92.4	84.3	102.0	63.4	112.6	41.2	87.1	81.6	96.0	60.9	105.9	38.6	81.5	78.8	89.6	58.2	98.8	36.0
3300	80	95.8	95.8	102.5	81.4	113.1	59.3	91.1	91.1	96.6	78.1	106.4	56.8	86.0	86.0	90.3	75.3	99.4	54.2
3300	85	101.8	101.8	103.8	98.5	113.5	77.3	96.8	96.8	98.0	95.8	106.8	74.8	91.5	91.5	92.0	92.0	99.9	72.2
3300	90	107.7	107.7	107.9	107.9	114.2	94.6	102.6	102.6	102.7	102.7	107.7	91.9	97.0	97.0	97.2	97.2	100.8	89.2
3600	75	93.8	88.8	103.1	66.1	113.7	41.8	88.4	86.0	96.9	63.5	106.8	39.3	82.7	82.7	90.4	60.8	99.5	36.6
3600	80	98.3	98.3	103.8	84.9	114.2	61.6	93.3	93.3	97.7	82.2	107.4	59.1	88.0	88.0	91.3	79.3	100.2	56.4
3600	85	104.4	104.4	105.5	104.3	114.6	81.3	99.2	99.2	99.6	99.6	107.8	78.8	93.7	93.7	93.7	93.7	100.7	76.1
3600	90	110.6	110.6	110.7	110.7	115.6	99.9	105.1	105.1	105.3	105.3	108.9	97.2	99.3	99.3	99.5	99.5	101.9	94.4
cfm	Ent DB (°F)	Ambient Temperature (°F)						Ambient Temperature (°F)											
		115						125											
		Entering Wet Bulb (°F)						Entering Wet Bulb (°F)											
		61		67		73		61		67		73							
		MBh	SHC	MBh	SHC	MBh	SHC	MBh	SHC	MBh	SHC	MBh	SHC						
2400	75	71.8	62.7	80.0	47.7	88.7	31.5	66.2	59.9	73.6	44.9	81.4	28.8						
2400	80	73.5	73.5	80.4	60.8	89.1	44.7	68.6	68.6	74.0	58.0	81.9	42.0						
2400	85	78.1	78.1	81.0	73.2	89.4	57.9	73.0	73.0	74.8	70.3	82.3	55.1						
2400	90	82.8	82.8	83.0	83.0	89.8	71.0	77.5	77.5	77.7	77.7	82.7	67.6						
2700	75	73.3	67.2	81.2	50.3	89.8	32.1	67.4	64.2	74.6	47.5	82.4	29.4						
2700	80	76.2	76.2	81.7	64.5	90.3	47.0	71.0	71.0	75.1	61.5	82.9	44.2						
2700	85	81.1	81.1	82.7	78.9	90.7	61.8	75.7	75.7	76.3	76.0	83.3	59.0						
2700	90	86.1	86.1	86.2	86.2	91.3	75.8	80.4	80.4	80.5	80.5	84.0	72.8						
3000	75	74.5	71.5	82.2	52.9	90.7	32.7	68.5	68.5	75.3	50.1	83.0	29.9						
3000	80	78.6	78.6	82.8	68.4	91.3	49.2	73.0	73.0	76.0	65.4	83.6	46.4						
3000	85	83.7	83.7	84.3	84.3	91.7	65.7	77.9	77.9	78.0	78.0	84.1	62.9						
3000	90	88.8	88.8	88.9	88.9	92.5	81.0	82.7	82.7	82.8	82.8	85.0	78.0						
3300	75	75.7	75.7	82.9	55.5	91.4	33.3	69.7	69.7	75.9	52.6	83.6	30.5						
3300	80	80.6	80.6	83.8	72.4	92.1	51.5	74.8	74.8	76.8	69.3	84.2	48.6						
3300	85	85.9	85.9	85.9	85.9	92.6	69.5	79.7	79.7	79.8	79.8	84.8	65.6						
3300	90	91.1	91.1	91.3	91.3	93.6	86.3	84.7	84.7	84.8	84.8	86.0	83.2						
3600	75	76.9	76.9	83.6	58.0	92.0	33.9	71.1	71.1	76.3	55.1	84.0	31.0						
3600	80	82.3	82.3	84.6	76.3	92.7	53.7	76.2	76.2	77.5	73.2	84.7	50.8						
3600	85	87.7	87.7	87.9	87.9	93.3	72.3	81.3	81.3	81.4	81.4	85.4	69.1						
3600	90	93.1	93.1	93.2	93.2	94.6	91.5	86.4	86.4	86.5	86.5	86.9	86.9						

**Notes:**

1. All capacities shown are gross and have not considered indoor fan heat. To obtain **NET** cooling capacity subtract indoor fan heat. For indoor fan heat formula, refer to appropriate airflow table notes.
2. MBh = Total Gross Capacity
3. SHC = Sensible Heat Capacity

## Gross Cooling Capacities

**Table 14. Gross cooling capacities 8.5 tons standard efficiency - three phase WSC102H3,4,W**

cfm	Ent DB (°F)	Ambient Temperature (°F)						Ambient Temperature (°F)						Ambient Temperature (°F)					
		85						95						105					
		Entering Wet Bulb (°F)						Entering Wet Bulb (°F)						Entering Wet Bulb (°F)					
		61		67		73		61		67		73		61		67		73	
		MBh	SHC	MBh	SHC	MBh	SHC	MBh	SHC	MBh	SHC	MBh	SHC	MBh	SHC	MBh	SHC	MBh	SHC
2720	75	94.0	78.7	104.8	60.7	116.6	42.1	89.2	76.4	99.5	58.3	110.6	39.7	84.1	73.8	93.9	55.8	104.2	37.2
2720	80	94.4	92.8	105.2	75.8	116.8	57.3	89.8	89.8	99.8	73.4	110.8	54.9	85.0	85.0	94.2	70.9	104.5	52.4
2720	85	97.5	97.5	105.4	90.8	117.1	72.4	93.5	93.5	100.1	88.4	111.1	70.0	89.2	89.2	94.5	85.9	104.9	67.6
2720	90	103.0	103.0	106.0	104.8	117.4	87.6	98.8	98.8	100.9	100.9	111.4	85.2	94.4	94.4	95.5	95.5	105.2	82.7
3060	75	96.0	84.3	106.9	63.9	118.7	43.0	90.9	81.8	101.3	61.4	112.4	40.5	85.7	79.2	95.4	58.9	105.7	37.9
3060	80	96.9	96.9	107.3	80.9	118.9	60.1	92.1	92.1	101.7	78.4	112.6	57.6	87.2	87.2	95.8	75.9	106.1	55.0
3060	85	101.6	101.6	107.6	97.8	119.3	77.1	97.3	97.3	102.1	95.3	113.1	74.7	92.7	92.7	96.3	91.5	106.5	72.1
3060	90	107.4	107.4	108.7	108.7	119.6	94.1	102.9	102.9	103.5	103.5	113.4	91.7	98.1	98.1	98.1	98.1	106.9	89.1
3400	75	97.6	89.7	108.6	67.1	120.4	43.8	92.3	85.9	102.8	64.5	113.8	41.3	87.0	83.2	96.7	61.9	106.9	38.6
3400	80	99.2	99.2	109.0	85.9	120.7	62.8	94.5	94.5	103.2	83.4	114.2	60.3	90.0	90.0	97.2	80.8	107.4	57.7
3400	85	105.1	105.1	109.4	103.4	121.1	81.8	100.5	100.5	103.8	100.7	114.6	79.3	95.6	95.6	97.8	97.8	107.9	76.7
3400	90	111.2	111.2	111.3	111.3	121.5	100.7	106.4	106.4	106.3	106.3	115.0	98.2	101.3	101.3	101.5	101.5	108.3	95.5
3740	75	99.0	93.7	110.1	70.2	121.8	44.6	93.7	91.0	104.0	67.6	115.0	42.0	88.1	88.1	97.7	64.9	107.9	39.3
3740	80	101.7	101.7	110.5	91.0	122.2	65.6	97.3	97.3	104.5	88.3	115.5	63.0	92.3	92.3	98.2	85.7	108.5	60.3
3740	85	108.2	108.2	111.1	110.0	122.6	86.4	103.3	103.3	105.3	105.3	116.0	83.8	98.2	98.2	99.3	99.3	109.0	81.2
3740	90	114.5	114.5	114.7	114.7	123.0	107.2	109.4	109.4	109.6	109.6	116.4	104.6	104.1	104.1	104.2	104.2	109.4	101.9
4080	75	100.3	98.8	111.3	73.3	122.9	45.4	94.9	94.9	105.1	70.6	115.9	42.7	89.2	89.2	98.6	67.9	108.6	40.0
4080	80	104.5	104.5	111.8	95.9	123.4	68.3	99.5	99.5	105.6	93.3	116.5	65.6	94.3	94.3	99.1	90.5	109.4	62.9
4080	85	110.9	110.9	112.7	112.7	123.9	91.0	105.8	105.8	106.8	106.8	117.1	88.4	100.4	100.4	100.7	100.7	109.9	85.7
4080	90	117.4	117.4	117.6	117.6	124.3	113.7	112.1	112.1	112.2	112.2	117.5	109.0	106.4	106.4	106.6	106.6	110.4	106.1
cfm	Ent DB (°F)	Ambient Temperature (°F)						Ambient Temperature (°F)											
		115						125											
		Entering Wet Bulb (°F)						Entering Wet Bulb (°F)											
		61		67		73		61		67		73							
		MBh	SHC	MBh	SHC	MBh	SHC	MBh	SHC	MBh	SHC	MBh	SHC						
2720	75	78.8	71.2	87.9	53.2	97.5	34.6	73.1	67.4	81.6	50.5	90.3	31.8						
2720	80	79.9	79.9	88.3	68.3	97.9	49.8	74.9	74.9	82.0	65.6	90.8	47.1						
2720	85	84.6	84.6	88.7	82.2	98.3	65.0	79.7	79.7	82.5	79.3	91.2	62.3						
2720	90	89.7	89.7	90.0	90.0	98.6	80.1	84.5	84.5	84.6	84.6	91.6	77.4						
3060	75	80.1	75.3	89.3	56.2	98.8	35.3	74.3	72.4	82.7	53.4	91.3	32.5						
3060	80	82.5	82.5	89.7	73.2	99.2	52.4	77.4	77.4	83.1	70.4	91.9	49.6						
3060	85	87.8	87.8	90.3	88.7	99.7	69.5	82.5	82.5	83.9	83.9	92.3	66.7						
3060	90	93.0	93.0	93.2	93.2	100.0	86.5	87.5	87.5	87.6	87.6	92.7	83.7						
3400	75	81.3	80.3	90.3	59.2	99.7	35.9	75.3	75.3	83.5	56.3	92.0	33.1						
3400	80	85.0	85.0	90.8	78.1	100.3	55.0	79.6	79.6	84.0	75.2	92.7	52.2						
3400	85	90.4	90.4	91.7	91.7	100.8	74.0	84.8	84.8	85.2	85.2	93.2	71.1						
3400	90	95.9	95.9	96.0	96.0	101.2	92.9	90.0	90.0	90.1	90.1	93.7	88.1						
3740	75	82.4	82.4	91.2	62.1	100.4	36.6	76.3	76.3	84.1	59.2	92.6	33.7						
3740	80	87.0	87.0	91.6	82.9	101.2	57.6	81.4	81.4	84.6	78.1	93.4	54.7						
3740	85	92.7	92.7	93.0	93.0	101.7	78.4	86.7	86.7	86.6	86.6	93.9	75.6						
3740	90	98.3	98.3	98.4	98.4	102.2	97.1	92.1	92.1	92.1	92.1	94.5	94.0						
4080	75	83.3	83.3	91.8	65.0	101.1	37.2	77.2	77.2	84.6	62.1	93.0	34.3						
4080	80	88.8	88.8	92.4	85.7	101.9	60.1	82.9	82.9	85.2	82.5	93.9	57.2						
4080	85	94.6	94.6	94.4	94.4	102.4	82.9	88.4	88.4	88.5	88.5	94.4	79.9						
4080	90	100.4	100.4	100.5	100.5	103.1	103.1	93.8	93.8	93.9	93.9	95.3	95.3						

**Notes:**

1. All capacities shown are gross and have not considered indoor fan heat. To obtain **NET** cooling capacity subtract indoor fan heat. For indoor fan heat formula, refer to appropriate airflow table notes.
2. MBh = Total Gross Capacity
3. SHC = Sensible Heat Capacity



## Gross Cooling Capacities

**Table 15. Gross cooling capacities 10 tons standard efficiency - three phase WSC120H3,4,W**

cfm	Ent DB (°F)	Ambient Temperature (°F)						Ambient Temperature (°F)						Ambient Temperature (°F)					
		85						95						105					
		Entering Wet Bulb (°F)						Entering Wet Bulb (°F)						Entering Wet Bulb (°F)					
		61		67		73		61		67		73		61		67		73	
	MBh	SHC	MBh	SHC	MBh	SHC	MBh	SHC	MBh	SHC	MBh	SHC	MBh	SHC	MBh	SHC	MBh	SHC	
3200	75	109.4	92.2	121.1	70.6	133.2	48.3	103.1	89.2	114.2	67.6	125.6	45.3	96.4	85.9	106.7	64.4	117.3	42.2
3200	80	110.5	108.9	121.4	88.4	133.6	66.2	104.6	104.6	114.6	85.4	126.0	63.2	98.2	98.2	107.1	82.1	117.9	60.1
3200	85	115.3	115.3	121.9	106.0	134.0	84.0	110.0	110.0	115.1	102.0	126.5	81.0	104.1	104.1	107.8	98.7	118.3	77.9
3200	90	121.6	121.6	123.2	122.6	134.3	101.7	116.0	116.0	116.7	116.7	126.8	98.8	109.9	109.9	110.0	110.0	118.7	95.7
3600	75	111.6	98.7	123.2	74.3	135.2	49.2	105.1	94.4	116.1	71.3	127.3	46.2	98.2	90.9	108.3	68.0	118.7	43.0
3600	80	113.5	113.5	123.6	94.3	135.7	69.3	107.6	107.6	116.5	91.2	127.9	66.4	101.6	101.6	108.8	87.9	119.4	63.2
3600	85	119.8	119.8	124.3	113.0	136.2	89.4	114.1	114.1	117.4	109.7	128.4	86.4	107.8	107.8	109.9	106.3	119.9	83.2
3600	90	126.3	126.3	126.5	126.5	136.5	109.3	120.4	120.4	120.6	120.6	128.8	106.4	113.9	113.9	114.0	114.0	120.5	103.2
4000	75	113.5	103.7	124.9	78.0	136.8	50.1	106.9	100.3	117.6	74.8	128.7	47.1	99.8	96.7	109.6	71.5	119.9	43.8
4000	80	116.8	116.8	125.4	100.1	137.4	72.5	111.0	111.0	118.1	97.0	129.4	69.5	104.5	104.5	110.1	93.7	120.7	66.2
4000	85	123.6	123.6	126.5	120.7	137.9	94.7	117.5	117.5	119.4	117.4	129.9	91.7	110.9	110.9	111.7	111.7	121.2	88.5
4000	90	130.3	130.3	130.5	130.5	138.4	116.9	124.1	124.1	124.2	124.2	130.5	113.9	117.2	117.2	117.3	117.3	121.9	108.9
4400	75	115.2	109.7	126.4	81.6	138.1	51.0	108.4	106.2	118.8	78.4	129.8	47.9	101.2	101.2	110.6	75.0	120.8	44.6
4400	80	119.9	119.9	126.9	105.9	138.9	75.6	113.7	113.7	119.4	102.8	130.6	72.6	107.0	107.0	111.3	97.5	121.7	69.3
4400	85	126.8	126.8	128.4	128.4	139.4	100.1	120.5	120.5	121.2	121.2	131.2	97.0	113.5	113.5	113.6	113.6	122.3	93.8
4400	90	133.8	133.8	134.0	134.0	140.0	122.7	127.2	127.2	127.4	127.4	132.0	119.5	120.0	120.0	120.1	120.1	123.3	115.9
4800	75	116.7	115.6	127.6	85.1	139.3	51.9	109.9	109.9	119.8	81.9	130.7	48.8	102.5	102.5	111.5	78.5	121.5	45.4
4800	80	122.5	122.5	128.2	110.0	140.1	78.7	116.1	116.1	120.5	106.5	131.7	75.6	109.1	109.1	112.3	102.8	122.6	72.3
4800	85	129.7	129.7	130.3	130.3	140.6	105.4	123.0	123.0	123.1	123.1	132.2	102.3	115.8	115.8	115.9	115.9	123.1	99.0
4800	90	136.8	136.8	137.0	137.0	141.5	129.9	129.9	129.9	130.1	130.1	133.3	126.5	122.4	122.4	122.5	122.5	124.5	122.9

cfm	Ent DB (°F)	Ambient Temperature (°F)						Ambient Temperature (°F)					
		115						125					
		Entering Wet Bulb (°F)						Entering Wet Bulb (°F)					
		61		67		73		61		67		73	
	MBh	SHC	MBh	SHC	MBh	SHC	MBh	SHC	MBh	SHC	MBh	SHC	
3200	75	89.4	81.4	98.9	61.1	108.5	38.9	82.3	77.8	90.7	57.7	99.2	35.5
3200	80	92.2	92.2	99.3	78.8	109.2	56.9	85.8	85.8	91.1	75.4	100.0	53.5
3200	85	97.8	97.8	100.2	95.2	109.7	74.7	91.1	91.1	92.2	91.5	100.5	71.3
3200	90	103.4	103.4	103.6	103.6	110.1	92.4	96.3	96.3	96.5	96.5	101.0	87.6
3600	75	91.0	87.2	100.2	64.6	109.6	39.7	83.6	83.5	91.7	61.2	100.1	36.3
3600	80	95.2	95.2	100.7	84.6	110.5	59.9	88.4	88.4	92.3	79.5	101.0	56.5
3600	85	101.1	101.1	102.0	102.0	111.0	79.9	93.9	93.9	94.0	94.0	101.5	76.5
3600	90	106.9	106.9	107.0	107.0	111.6	98.3	99.3	99.3	99.4	99.4	102.3	94.5
4000	75	92.4	92.4	101.2	68.1	110.5	40.5	85.0	85.0	92.5	64.6	100.7	37.0
4000	80	97.7	97.7	101.9	88.5	111.5	62.9	90.5	90.5	93.2	84.7	101.7	59.4
4000	85	103.8	103.8	103.9	103.9	112.0	85.2	96.2	96.2	96.3	96.3	102.3	81.7
4000	90	109.7	109.7	109.9	109.9	112.9	105.2	101.7	101.7	101.8	101.8	103.4	101.4
4400	75	93.8	93.8	102.0	71.5	111.3	41.2	86.5	86.5	93.1	68.0	101.2	37.7
4400	80	99.9	99.9	102.9	93.7	112.3	65.9	92.3	92.3	94.1	89.8	102.3	62.4
4400	85	106.1	106.1	106.2	106.2	112.9	90.4	98.0	98.0	98.1	98.1	102.9	84.5
4400	90	112.2	112.2	112.3	112.3	114.1	112.2	103.7	103.7	103.8	103.8	104.4	104.4
4800	75	95.2	95.2	102.7	75.0	111.8	42.0	87.9	87.9	93.5	71.3	101.6	38.4
4800	80	101.7	101.7	103.7	98.9	112.9	68.9	93.8	93.8	94.8	94.8	102.8	65.3
4800	85	108.0	108.0	108.1	108.1	113.5	93.2	99.6	99.6	99.7	99.7	103.5	89.1
4800	90	114.2	114.2	114.3	114.3	115.2	115.2	105.4	105.4	105.5	105.5	105.5	105.5

**Notes:**

1. All capacities shown are gross and have not considered indoor fan heat. To obtain **NET** cooling capacity subtract indoor fan heat. For indoor fan heat formula, refer to appropriate airflow table notes.
2. MBh = Total Gross Capacity
3. SHC = Sensible Heat Capacity



## Gross Cooling Capacities

**Table 16. Gross cooling capacities 3 tons - high efficiency high stage - three phase W/DHC036H3,4,W**

cfm	Ent DB (°F)	Ambient Temperature (°F)						Ambient Temperature (°F)						Ambient Temperature (°F)					
		85						95						105					
		Entering Wet Bulb (°F)						Entering Wet Bulb (°F)						Entering Wet Bulb (°F)					
		61		67		73		61		67		73		61		67		73	
		MBh	SHC	MBh	SHC	MBh	SHC	MBh	SHC	MBh	SHC	MBh	SHC	MBh	SHC	MBh	SHC		
960	75	33.4	26.8	37.6	20.7	42.1	14.4	31.0	25.4	35.1	19.4	39.3	13.1	28.6	24.0	32.4	18.0	36.4	11.7
960	80	33.5	31.8	37.7	25.9	42.2	19.7	31.2	30.4	35.2	24.6	39.4	18.3	28.8	28.8	32.6	23.2	36.5	17.0
960	85	34.5	34.5	37.8	31.1	42.3	24.9	32.6	32.6	35.3	29.8	39.6	23.6	30.5	30.5	32.6	28.4	36.7	22.2
960	90	36.6	36.6	37.9	36.1	42.4	30.2	34.7	34.7	35.5	34.7	39.7	28.8	32.5	32.5	32.9	32.9	36.8	27.4
1080	75	34.1	28.7	38.4	21.8	42.8	14.7	31.7	27.3	35.7	20.4	39.9	13.3	29.1	25.6	33.0	19.0	36.9	11.9
1080	80	34.4	34.3	38.5	27.7	43.0	20.6	32.0	32.0	35.9	26.3	40.1	19.3	29.8	29.8	33.1	24.9	37.1	17.9
1080	85	36.2	36.2	38.6	33.5	43.1	26.6	34.1	34.1	36.0	31.9	40.3	25.2	31.9	31.9	33.3	30.5	37.3	23.8
1080	90	38.4	38.4	38.9	38.9	43.2	32.4	36.3	36.3	36.4	36.4	40.4	31.1	34.0	34.0	34.1	34.1	37.4	29.6
1200	75	34.7	30.4	39.0	22.9	43.5	15.0	32.2	28.9	36.2	21.5	40.4	13.6	29.6	27.4	33.4	20.0	37.3	12.1
1200	80	35.2	35.2	39.1	29.4	43.6	21.6	33.1	33.1	36.4	28.0	40.6	20.2	30.8	30.8	33.5	26.5	37.5	18.7
1200	85	37.6	37.6	39.3	35.7	43.8	28.2	35.4	35.4	36.6	34.2	40.8	26.8	33.0	33.0	33.8	32.7	37.7	25.3
1200	90	40.0	40.0	40.1	40.1	43.9	34.7	37.7	37.7	37.8	37.8	41.0	33.3	35.3	35.3	35.3	35.3	37.9	31.8
1320	75	35.3	32.1	39.5	24.0	43.9	15.3	32.7	30.6	36.7	22.5	40.8	13.8	30.0	29.1	33.7	21.0	37.6	12.3
1320	80	36.4	36.4	39.7	31.2	44.2	22.5	34.1	34.1	36.8	29.7	41.1	21.1	31.7	31.7	33.9	28.2	37.8	19.6
1320	85	38.9	38.9	40.0	38.0	44.4	29.8	36.5	36.5	37.2	36.5	41.3	28.3	34.0	34.0	34.3	34.3	38.0	26.8
1320	90	41.3	41.3	41.4	41.4	44.5	36.9	38.9	38.9	39.0	39.0	41.5	35.5	36.4	36.4	36.4	36.4	38.3	33.7
1440	75	35.7	33.9	39.9	25.0	44.4	15.5	33.1	32.4	37.0	23.5	41.2	14.1	30.3	30.3	33.9	22.0	37.8	12.6
1440	80	37.4	37.4	40.1	32.9	44.6	23.5	35.0	35.0	37.2	31.4	41.4	22.0	32.5	32.5	34.2	29.5	38.1	20.5
1440	85	40.0	40.0	40.6	40.3	44.8	31.3	37.5	37.5	37.7	37.7	41.6	29.9	34.9	34.9	34.9	34.9	38.3	28.3
1440	90	42.6	42.6	42.6	42.6	45.0	39.2	40.0	40.0	40.1	40.1	41.9	37.3	37.3	37.4	37.4	37.4	38.6	35.8

cfm	Ent DB (°F)	Ambient Temperature (°F)						Ambient Temperature (°F)					
		115						125					
		Entering Wet Bulb (°F)						Entering Wet Bulb (°F)					
		61		67		73		61		67		73	
		MBh	SHC	MBh	SHC	MBh	SHC	MBh	SHC	MBh	SHC	MBh	SHC
960	75	26.1	22.6	29.6	16.5	33.3	10.3	23.4	20.9	26.7	15.1	30.1	8.8
960	80	26.3	26.3	29.8	21.8	33.5	15.5	24.1	24.1	26.8	20.3	30.3	14.1
960	85	28.3	28.3	29.9	26.7	33.7	20.8	26.0	26.0	27.0	25.2	30.4	19.3
960	90	30.3	30.3	30.4	30.4	33.8	26.0	27.9	27.9	27.9	27.9	30.6	24.5
1080	75	26.5	24.1	30.1	17.5	33.7	10.5	23.7	22.5	27.0	16.0	30.4	9.0
1080	80	27.5	27.5	30.2	23.4	33.9	16.4	25.1	25.1	27.2	21.9	30.6	14.9
1080	85	29.5	29.5	30.4	29.0	34.1	22.3	27.0	27.0	27.4	27.4	30.8	20.8
1080	90	31.6	31.6	31.7	31.7	34.2	28.2	29.0	29.0	29.1	29.1	30.9	26.4
1200	75	26.9	25.8	30.4	18.5	34.0	10.7	24.0	24.0	27.2	16.9	30.5	9.1
1200	80	28.4	28.4	30.5	25.0	34.3	17.3	25.8	25.8	27.4	23.1	30.8	15.7
1200	85	30.6	30.6	30.9	30.9	34.5	23.8	27.9	27.9	27.9	27.9	31.0	22.3
1200	90	32.7	32.7	32.8	32.8	34.6	30.0	30.0	30.0	30.0	30.0	31.2	28.4
1320	75	27.2	27.2	30.6	19.5	34.2	10.8	24.3	24.3	27.3	17.9	30.6	9.3
1320	80	29.2	29.2	30.8	26.3	34.5	18.1	26.5	26.5	27.6	24.6	30.9	16.5
1320	85	31.4	31.4	31.5	31.5	34.7	25.3	28.6	28.6	28.7	28.7	31.1	23.7
1320	90	33.7	33.7	33.7	33.7	35.0	32.1	30.7	30.7	30.8	30.8	31.5	30.4
1440	75	27.5	27.5	30.7	20.4	34.4	11.0	24.8	24.8	27.4	18.8	30.7	9.4
1440	80	29.8	29.8	31.0	27.8	34.7	18.9	27.0	27.0	27.7	26.1	31.0	17.3
1440	85	32.2	32.2	32.2	32.2	34.9	26.8	29.2	29.2	29.3	29.3	31.3	24.7
1440	90	34.5	34.5	34.5	34.5	35.3	34.1	31.4	31.4	31.5	31.5	31.7	31.7

**Notes:**

1. All capacities shown are gross and have not considered indoor fan heat. To obtain **NET** cooling capacity subtract indoor fan heat. For indoor fan heat formula, refer to appropriate airflow table notes.
2. MBh = Total Gross Capacity
3. SHC = Sensible Heat Capacity



## Gross Cooling Capacities

**Table 17. Gross cooling capacities 3 tons - high efficiency low stage - three phase W/DHC036H3,4,W**

cfm	Ent DB (°F)	Ambient Temperature (°F)						Ambient Temperature (°F)					
		85						95					
		Entering Wet Bulb (°F)						Entering Wet Bulb (°F)					
		61		67		73		61		67		73	
		MBh	SHC	MBh	SHC	MBh	SHC	MBh	SHC	MBh	SHC	MBh	SHC
600	75	22.7	17.5	25.9	13.7	29.3	9.9	21.0	16.4	24.0	12.7	27.2	8.8
600	80	22.7	20.6	25.9	17.1	29.3	13.2	21.0	19.6	24.1	16.0	27.3	12.2
600	85	22.9	22.9	26.0	20.4	29.4	16.6	21.5	21.5	24.1	19.3	27.4	15.5
600	90	24.4	24.4	25.9	23.5	29.4	19.9	23.0	23.0	24.1	22.5	27.5	18.8
720	75	23.6	19.5	26.9	14.9	30.3	10.2	21.8	18.3	24.9	13.9	28.1	9.2
720	80	23.7	23.2	27.0	18.9	30.4	14.3	21.9	21.9	25.0	17.8	28.2	13.2
720	85	24.8	24.8	27.0	22.9	30.5	18.3	23.3	23.3	25.0	21.7	28.3	17.2
720	90	26.5	26.5	27.1	26.7	30.5	22.3	24.9	24.9	25.1	25.1	28.4	21.2
840	75	24.3	21.3	27.6	16.1	31.0	10.6	22.4	20.1	25.5	15.0	28.7	9.5
840	80	24.7	24.7	27.7	20.7	31.2	15.3	23.0	23.0	25.6	19.6	28.9	14.2
840	85	26.4	26.4	27.8	25.2	31.3	20.0	24.8	24.8	25.7	24.0	29.0	18.8
840	90	28.2	28.2	28.3	28.3	31.3	24.6	26.5	26.5	26.6	26.6	29.1	23.5
960	75	24.9	23.1	28.1	17.2	31.5	10.9	22.8	21.9	25.9	16.0	29.1	9.7
960	80	25.9	25.9	28.3	22.5	31.7	16.2	24.1	24.1	26.0	21.1	29.3	15.1
960	85	27.8	27.8	28.5	27.6	31.9	21.6	26.0	26.0	26.3	26.3	29.5	20.4
960	90	29.7	29.7	29.8	29.8	32.0	26.7	27.8	27.8	27.9	27.9	29.6	25.5

**Notes:**

1. All capacities shown are gross and have not considered indoor fan heat. To obtain **NET** cooling capacity subtract indoor fan heat. For indoor fan heat formula, refer to appropriate airflow table notes.
2. MBh = Total Gross Capacity
3. SHC = Sensible Heat Capacity

## Gross Cooling Capacities

**Table 18. Gross cooling capacities 4 tons - high stage - three phase W/DHC048H3,4,W**

cfm	Ent DB (°F)	Ambient Temperature (°F)						Ambient Temperature (°F)						Ambient Temperature (°F)					
		85						95						105					
		Entering Wet Bulb (°F)						Entering Wet Bulb (°F)						Entering Wet Bulb (°F)					
		61		67		73		61		67		73		61		67		73	
		MBh	SHC	MBh	SHC	MBh	SHC	MBh	SHC	MBh	SHC	MBh	SHC	MBh	SHC	MBh	SHC		
1280	75	45.0	37.2	50.3	28.7	55.8	19.9	42.1	35.7	47.0	27.2	52.2	18.4	38.9	34.1	43.6	25.6	48.3	16.8
1280	80	45.2	43.9	50.5	35.9	56.0	27.2	42.3	42.3	47.3	34.4	52.4	25.6	39.3	39.3	43.9	32.8	48.6	24.1
1280	85	46.3	46.3	50.7	43.1	56.2	34.4	43.9	43.9	47.5	41.6	52.7	32.9	41.3	41.3	44.1	40.0	48.9	31.3
1280	90	49.1	49.1	50.9	49.6	56.4	41.6	46.6	46.6	47.8	47.8	53.0	40.1	43.9	43.9	44.5	44.5	49.2	38.5
1440	75	45.9	39.8	51.2	30.2	56.7	20.3	42.8	38.2	47.8	28.7	52.9	18.7	39.5	36.6	44.2	27.0	48.8	17.1
1440	80	46.3	46.3	51.5	38.3	57.0	28.4	43.3	43.3	48.1	36.7	53.2	26.9	40.2	40.2	44.5	35.1	49.3	25.3
1440	85	48.4	48.4	51.7	46.4	57.2	36.6	45.8	45.8	48.3	44.2	53.5	35.0	43.0	43.0	44.8	42.5	49.6	33.4
1440	90	51.3	51.3	52.1	52.1	57.5	44.7	48.6	48.6	48.9	48.9	53.8	43.1	45.7	45.7	45.7	45.7	49.8	41.5
1600	75	46.7	42.4	52.0	31.7	57.4	20.6	43.4	40.7	48.4	30.1	53.4	19.0	40.1	38.1	44.7	28.4	49.3	17.4
1600	80	47.3	47.3	52.3	40.7	57.7	29.7	44.4	44.4	48.8	39.1	53.9	28.1	41.5	41.5	45.0	37.4	49.7	26.5
1600	85	50.2	50.2	52.5	49.0	58.0	38.7	47.4	47.4	49.1	47.3	54.2	37.2	44.4	44.4	45.4	45.4	50.1	35.5
1600	90	53.2	53.2	53.3	53.3	58.3	47.7	50.3	50.3	50.4	50.4	54.5	46.2	47.2	47.2	47.2	47.2	50.4	44.5
1760	75	47.3	44.9	52.6	33.1	57.9	21.0	44.0	42.4	48.9	31.5	53.9	19.4	40.5	40.5	45.1	29.8	49.6	17.7
1760	80	48.6	48.6	52.9	43.0	58.4	31.0	45.7	45.7	49.3	41.4	54.4	29.4	42.6	42.6	45.4	39.6	50.1	27.7
1760	85	51.7	51.7	53.3	52.1	58.7	40.9	48.7	48.7	49.8	49.8	54.7	39.3	45.5	45.5	46.0	46.0	50.5	37.6
1760	90	54.9	54.8	54.9	54.9	59.0	50.8	51.8	51.8	51.8	51.8	55.1	49.2	48.4	48.4	48.5	48.5	50.8	46.5
1920	75	47.9	46.6	53.1	34.6	58.4	21.3	44.5	44.5	49.3	32.9	54.2	19.7	40.9	40.9	45.3	31.1	49.8	17.9
1920	80	49.8	49.8	53.5	45.3	58.9	32.2	46.8	46.8	49.7	43.6	54.8	30.6	43.6	43.6	45.7	40.9	50.4	28.8
1920	85	53.1	53.1	54.0	54.0	59.3	43.1	49.9	49.9	50.4	50.4	55.2	41.4	46.6	46.6	46.6	46.6	50.8	39.7
1920	90	56.3	56.3	56.4	56.4	59.6	53.8	53.0	53.0	53.1	53.1	55.5	51.2	49.5	49.5	49.6	49.6	51.2	49.3
cfm	Ent DB (°F)	Ambient Temperature (°F)						Ambient Temperature (°F)											
		115						125											
		Entering Wet Bulb (°F)						Entering Wet Bulb (°F)											
		61		67		73		61		67		73							
		MBh	SHC	MBh	SHC	MBh	SHC	MBh	SHC	MBh	SHC	MBh	SHC						
1280	75	35.6	31.9	40.0	24.0	44.2	15.2	32.1	30.1	36.1	22.3	39.9	13.5						
1280	80	36.1	36.1	40.3	31.2	44.6	22.5	33.2	33.2	36.4	29.5	40.3	20.8						
1280	85	38.5	38.5	40.5	37.7	44.9	29.7	35.5	35.5	36.7	35.9	40.6	28.0						
1280	90	41.0	41.0	41.0	41.0	45.2	36.9	37.8	37.8	37.9	37.9	40.9	35.2						
1440	75	36.1	34.2	40.4	25.3	44.6	15.4	32.5	32.3	36.4	23.6	40.1	13.7						
1440	80	37.4	37.4	40.8	33.4	45.1	23.6	34.2	34.2	36.7	31.7	40.6	21.9						
1440	85	40.0	40.0	41.1	40.7	45.4	31.8	36.7	36.7	37.2	37.2	40.9	30.0						
1440	90	42.5	42.5	42.6	42.6	45.7	39.9	39.1	39.1	39.2	39.2	41.2	37.2						
1600	75	36.6	36.4	40.8	26.7	44.9	15.7	32.9	32.9	36.6	24.9	40.2	13.9						
1600	80	38.4	38.4	41.1	35.7	45.4	24.8	35.1	35.1	36.9	32.9	40.8	23.0						
1600	85	41.1	41.1	41.6	41.6	45.8	33.8	37.6	37.6	37.7	37.7	41.1	32.0						
1600	90	43.8	43.8	43.9	43.9	46.1	41.9	40.1	40.1	40.2	40.2	41.5	39.9						
1760	75	36.9	36.9	41.0	28.0	45.1	15.9	33.2	33.2	36.7	26.1	40.3	14.1						
1760	80	39.4	39.4	41.3	36.9	45.7	25.9	35.8	35.8	37.1	34.9	40.9	24.1						
1760	85	42.1	42.1	42.2	42.2	46.0	35.9	38.4	38.4	38.5	38.5	41.2	34.0						
1760	90	44.9	44.9	44.9	44.9	46.4	44.6	41.0	41.0	41.0	41.0	41.7	41.7						
1920	75	37.3	37.3	41.1	29.3	45.2	16.1	33.7	33.7	36.7	27.4	40.3	14.3						
1920	80	40.1	40.1	41.6	39.0	45.8	27.1	36.4	36.4	37.2	36.8	40.9	25.2						
1920	85	43.0	43.0	43.0	43.0	46.2	37.9	39.0	39.0	39.1	39.1	41.3	34.8						
1920	90	45.8	45.8	45.8	45.8	46.7	46.7	41.6	41.6	41.7	41.7	42.0	42.0						

**Notes:**

1. All capacities shown are gross and have not considered indoor fan heat. To obtain **NET** cooling capacity subtract indoor fan heat. For indoor fan heat formula, refer to appropriate airflow table notes.
2. MBh = Total Gross Capacity
3. SHC = Sensible Heat Capacity



## Gross Cooling Capacities

**Table 19. Gross cooling capacities 4 tons - low stage - three phase W/DHC048H3,4,W**

cfm	Ent DB (°F)	Ambient Temperature (°F)						Ambient Temperature (°F)					
		85						95					
		Entering Wet Bulb (°F)						Entering Wet Bulb (°F)					
		61		67		73		61		67		73	
		MBh	SHC	MBh	SHC	MBh	SHC	MBh	SHC	MBh	SHC	MBh	SHC
800	75	30.3	23.9	34.3	18.9	38.5	13.6	30.3	23.9	34.3	18.9	38.5	13.6
800	80	30.3	28.0	34.5	23.3	38.7	18.1	30.3	28.0	34.5	23.3	38.7	18.1
800	85	30.3	30.3	34.6	27.7	38.9	22.5	30.3	30.3	34.6	27.7	38.9	22.5
800	90	32.3	32.3	34.6	31.8	39.0	27.0	32.3	32.3	34.6	31.8	39.0	27.0
960	75	31.4	26.5	35.5	20.4	39.7	14.0	31.4	26.5	35.5	20.4	39.7	14.0
960	80	31.5	31.4	35.7	25.7	39.9	19.4	31.5	31.4	35.7	25.7	39.9	19.4
960	85	32.8	32.8	35.8	31.0	40.1	24.8	32.8	32.8	35.8	31.0	40.1	24.8
960	90	34.9	34.9	35.9	35.9	40.3	30.1	34.9	34.9	35.9	35.9	40.3	30.1
1120	75	32.2	28.6	36.3	21.8	40.4	14.4	32.2	28.6	36.3	21.8	40.4	14.4
1120	80	32.5	32.5	36.6	28.1	40.8	20.7	32.5	32.5	36.6	28.1	40.8	20.7
1120	85	34.8	34.8	36.8	33.8	41.1	26.9	34.8	34.8	36.8	33.8	41.1	26.9
1120	90	37.1	37.1	37.1	37.1	41.3	33.2	37.1	37.1	37.1	37.1	41.3	33.2
1280	75	32.9	31.0	37.0	23.3	41.0	14.7	32.9	31.0	37.0	23.3	41.0	14.7
1280	80	34.0	34.0	37.3	30.4	41.5	21.9	34.0	34.0	37.3	30.4	41.5	21.9
1280	85	36.4	36.4	37.5	36.9	41.8	29.1	36.4	36.4	37.5	36.9	41.8	29.1
1280	90	38.9	38.9	38.9	38.9	42.0	36.2	38.9	38.9	38.9	38.9	42.0	36.2

**Notes:**

1. All capacities shown are gross and have not considered indoor fan heat. To obtain **NET** cooling capacity subtract indoor fan heat. For indoor fan heat formula, refer to appropriate airflow table notes.
2. MBh = Total Gross Capacity
3. SHC = Sensible Heat Capacity

## Gross Cooling Capacities

**Table 20. Gross cooling capacities 5 tons - high stage - three phase W/DHC060H3,4,W**

cfm	Ent DB (°F)	Ambient Temperature (°F)						Ambient Temperature (°F)						Ambient Temperature (°F)					
		85						95						105					
		Entering Wet Bulb (°F)						Entering Wet Bulb (°F)						Entering Wet Bulb (°F)					
		61		67		73		61		67		73		61		67		73	
		MBh	SHC	MBh	SHC	MBh	SHC	MBh	SHC	MBh	SHC	MBh	SHC	MBh	SHC	MBh	SHC		
1600	75	56.2	46.7	62.8	36.0	69.9	25.0	52.7	44.9	59.0	34.2	65.6	23.2	49.1	43.0	54.9	32.3	61.0	21.3
1600	80	56.6	55.2	63.1	45.0	70.1	34.0	53.2	53.2	59.2	43.2	65.8	32.3	49.7	49.7	55.2	41.4	61.3	30.4
1600	85	58.5	58.5	63.2	54.0	70.3	43.1	55.6	55.6	59.5	52.2	66.0	41.3	52.5	52.5	55.4	50.4	61.5	39.5
1600	90	61.9	61.9	63.7	62.5	70.4	52.1	58.9	58.9	60.0	60.0	66.3	50.3	55.7	55.7	56.2	56.2	61.8	48.5
1800	75	57.3	49.9	64.0	37.9	71.1	25.5	53.7	48.1	60.0	36.0	66.6	23.6	49.9	46.2	55.7	34.1	61.8	21.7
1800	80	58.1	58.1	64.3	48.0	71.3	35.7	54.6	54.6	60.2	46.2	66.8	33.8	51.0	51.0	56.0	44.2	62.1	31.9
1800	85	61.0	61.0	64.5	58.1	71.5	45.8	57.9	57.9	60.6	56.3	67.1	44.0	54.5	54.5	56.4	53.8	62.3	42.1
1800	90	64.6	64.6	65.3	65.3	71.7	56.0	61.4	61.4	61.6	61.6	67.3	54.2	57.9	57.9	58.0	58.0	62.6	52.3
2000	75	58.3	53.1	64.9	39.7	72.0	25.9	54.5	51.2	60.7	37.8	67.3	24.0	50.6	48.4	56.3	35.8	62.3	22.0
2000	80	59.5	59.5	65.2	51.0	72.3	37.3	56.2	56.2	61.0	49.1	67.6	35.4	52.7	52.7	56.6	47.1	62.7	33.4
2000	85	63.2	63.2	65.7	62.2	72.5	48.6	59.8	59.8	61.6	59.7	67.9	46.7	56.2	56.2	57.3	57.3	63.0	44.7
2000	90	67.0	67.0	67.0	67.0	72.8	59.8	63.5	63.5	63.6	63.6	68.2	58.0	59.7	59.7	59.8	59.8	63.4	56.0
2200	75	59.2	56.3	65.7	41.5	72.8	26.4	55.3	53.7	61.4	39.6	67.9	24.4	51.2	51.2	56.8	37.5	62.8	22.4
2200	80	61.2	61.2	66.0	53.9	73.1	38.9	57.7	57.7	61.7	52.0	68.3	36.9	54.0	54.0	57.1	50.0	63.2	34.9
2200	85	65.1	65.1	66.7	65.6	73.4	51.3	61.5	61.5	62.5	62.5	68.6	49.4	57.7	57.7	58.1	58.1	63.5	47.4
2200	90	69.0	69.0	69.1	69.1	73.7	63.7	65.3	65.3	65.4	65.4	69.0	61.8	61.3	61.3	61.4	61.4	64.0	59.8
2400	75	59.9	58.8	66.4	43.3	73.4	26.8	56.0	56.0	61.9	41.3	68.4	24.8	51.8	51.8	57.1	39.2	63.1	22.7
2400	80	62.7	62.7	66.7	56.8	73.8	40.4	59.1	59.1	62.3	54.8	68.8	38.4	55.2	55.2	57.6	52.8	63.6	36.4
2400	85	66.7	66.7	67.7	67.7	74.1	54.0	63.0	63.0	63.4	63.4	69.1	52.0	58.9	58.9	59.0	59.0	63.9	50.0
2400	90	70.8	70.8	70.9	70.9	74.5	67.5	66.9	66.9	67.0	67.0	69.7	65.6	62.7	62.7	62.8	62.8	64.5	62.6
cfm	Ent DB (°F)	Ambient Temperature (°F)						Ambient Temperature (°F)											
		115						125											
		Entering Wet Bulb (°F)						Entering Wet Bulb (°F)											
		61		67		73		61		67		73							
		MBh	SHC	MBh	SHC	MBh	SHC	MBh	SHC	MBh	SHC								
1600	75	45.2	41.1	50.6	30.4	56.2	19.4	41.1	38.5	46.0	28.4	51.0	17.4						
1600	80	46.0	46.0	50.9	39.4	56.5	28.5	42.6	42.6	46.3	37.4	51.3	26.5						
1600	85	49.1	49.1	51.2	48.5	56.8	37.5	45.5	45.5	46.7	45.8	51.6	35.5						
1600	90	52.2	52.2	52.3	52.3	57.0	46.6	48.4	48.4	48.5	48.5	51.9	44.6						
1800	75	45.8	43.6	51.2	32.1	56.7	19.7	41.6	41.4	46.4	30.0	51.4	17.6						
1800	80	47.7	47.7	51.5	42.3	57.1	30.0	43.9	43.9	46.7	40.2	51.7	27.9						
1800	85	50.9	50.9	52.0	51.7	57.4	40.1	47.0	47.0	47.4	47.4	52.1	38.1						
1800	90	54.1	54.1	54.2	54.2	57.7	50.3	50.0	50.0	50.1	50.1	52.4	48.3						
2000	75	46.5	46.5	51.6	33.8	57.1	20.0	42.1	42.1	46.7	31.7	51.6	17.9						
2000	80	49.0	49.0	52.0	45.1	57.5	31.4	45.0	45.0	47.1	43.0	52.0	29.3						
2000	85	52.4	52.4	52.8	52.8	57.9	42.7	48.2	48.2	48.2	48.2	52.3	40.6						
2000	90	55.7	55.7	55.8	55.8	58.3	54.0	51.3	51.3	51.4	51.4	52.8	51.0						
2200	75	47.0	47.0	52.0	35.5	57.4	20.3	42.6	42.6	46.8	33.3	51.7	18.2						
2200	80	50.2	50.2	52.4	47.9	57.9	32.9	45.9	45.9	47.3	44.8	52.2	30.7						
2200	85	53.6	53.6	53.6	53.6	58.2	45.3	49.2	49.2	49.2	49.2	52.5	43.2						
2200	90	57.1	57.1	57.1	57.1	58.8	56.8	52.4	52.4	52.4	52.4	53.3	53.3						
2400	75	47.5	47.5	52.2	37.1	57.6	20.6	43.3	43.3	46.9	34.9	51.8	18.4						
2400	80	51.1	51.1	52.7	49.7	58.1	34.3	46.7	46.7	47.6	47.3	52.3	32.1						
2400	85	54.7	54.7	54.7	54.7	58.5	47.9	50.0	50.0	50.1	50.1	52.7	45.7						
2400	90	58.2	58.2	58.3	58.3	59.3	59.3	53.3	53.3	53.3	53.3	53.6	53.6						

**Notes:**

1. All capacities shown are gross and have not considered indoor fan heat. To obtain **NET** cooling capacity subtract indoor fan heat. For indoor fan heat formula, refer to appropriate airflow table notes.
2. MBh = Total Gross Capacity
3. SHC = Sensible Heat Capacity



## Gross Cooling Capacities

**Table 21. Gross cooling capacities 5 tons - low stage - three phase W/DHC060H3,4,W**

cfm	Ent DB (°F)	Ambient Temperature (°F)						Ambient Temperature (°F)					
		85						95					
		Entering Wet Bulb (°F)						Entering Wet Bulb (°F)					
		61		67		73		61		67		73	
		MBh	SHC	MBh	SHC	MBh	SHC	MBh	SHC	MBh	SHC	MBh	SHC
1000	75	37.3	29.7	42.3	23.4	47.8	16.9	34.8	28.4	39.6	22.1	44.7	15.6
1000	80	37.3	35.2	42.4	29.0	47.9	22.5	34.8	33.6	39.7	27.7	44.8	21.1
1000	85	37.3	37.3	42.6	34.5	48.0	28.0	35.3	35.3	39.9	33.2	45.0	26.7
1000	90	39.6	39.6	42.5	39.9	48.1	33.6	37.6	37.6	39.9	38.6	45.1	32.3
1200	75	38.7	33.0	43.8	25.4	49.3	17.4	36.0	31.6	40.8	23.9	46.0	16.0
1200	80	38.8	38.8	44.0	32.0	49.4	24.2	36.1	36.1	41.0	30.6	46.1	22.7
1200	85	40.3	40.3	44.1	38.6	49.6	30.8	38.1	38.1	41.2	37.2	46.3	29.4
1200	90	42.9	42.9	44.2	44.2	49.7	37.5	40.6	40.6	41.4	41.4	46.5	36.1
1400	75	39.6	36.2	44.8	27.2	50.4	17.9	36.7	34.7	41.7	25.7	46.8	16.5
1400	80	40.1	40.1	45.1	35.0	50.6	25.8	37.6	37.6	41.9	33.5	47.1	24.3
1400	85	42.7	42.7	45.2	42.7	50.8	33.6	40.3	40.3	42.1	40.8	47.3	32.1
1400	90	45.5	45.5	45.8	45.8	51.0	41.4	43.0	43.0	43.1	43.1	47.5	39.9
1600	75	40.4	39.3	45.6	29.0	51.2	18.4	37.4	37.2	42.3	27.5	47.4	16.9
1600	80	41.8	41.8	45.9	37.9	51.4	27.4	39.2	39.2	42.6	36.3	47.7	25.8
1600	85	44.8	44.8	46.2	46.2	51.7	36.3	42.1	42.1	43.0	43.0	48.0	34.7
1600	90	47.8	47.8	47.9	47.9	51.9	45.2	45.0	45.0	45.1	45.1	48.3	43.6

**Notes:**

1. All capacities shown are gross and have not considered indoor fan heat. To obtain **NET** cooling capacity subtract indoor fan heat. For indoor fan heat formula, refer to appropriate airflow table notes.
2. MBh = Total Gross Capacity
3. SHC = Sensible Heat Capacity

**Table 22. Gross cooling capacities 6 tons high efficiency - stage 1 - three phase W/DHC074H3,4,W**

cfm	Ent DB (°F)	Ambient Temperature (°F)						Ambient Temperature (°F)					
		85						95					
		Entering Wet Bulb (°F)						Entering Wet Bulb (°F)					
		61		67		73		61		67		73	
		MBh	SHC	MBh	SHC	MBh	SHC	MBh	SHC	MBh	SHC	MBh	SHC
960	75	29.6	25.5	33.6	19.8	37.7	13.5	27.6	24.4	31.4	18.8	35.3	12.4
960	80	29.7	29.7	33.7	25.1	37.9	18.9	27.8	27.8	31.6	23.8	35.6	17.8
960	85	31.4	31.4	33.8	29.9	38.1	24.2	29.8	29.8	31.6	28.9	35.8	23.2
960	90	33.5	33.5	33.8	33.8	38.2	29.2	31.8	31.8	31.9	31.9	35.9	28.1
1200	75	30.8	29.1	34.8	22.0	38.8	14.1	28.7	28.0	32.4	21.0	36.2	13.0
1200	80	31.9	31.9	35.0	28.2	39.2	20.8	30.1	30.1	32.6	27.0	36.7	19.8
1200	85	34.2	34.2	35.1	34.6	39.4	27.5	32.4	32.4	32.9	32.9	36.9	26.5
1200	90	36.5	36.5	36.6	36.6	39.6	33.5	34.6	34.6	34.7	34.7	37.1	32.4
1440	75	31.7	31.7	35.5	24.2	39.5	14.6	29.5	29.5	33.1	22.5	36.8	13.5
1440	80	33.9	33.9	35.8	31.4	40.0	22.7	31.9	31.9	33.4	30.2	37.4	21.6
1440	85	36.4	36.4	36.4	36.4	40.3	30.1	34.3	34.3	34.4	34.4	37.7	28.9
1440	90	38.9	38.9	38.9	38.9	40.6	37.9	36.8	36.8	36.9	36.9	38.0	36.7
1680	75	32.8	32.8	36.1	25.6	40.0	15.1	30.7	30.7	33.5	24.3	37.1	14.0
1680	80	35.4	35.4	36.5	34.7	40.6	24.6	33.3	33.3	34.0	33.4	37.9	23.5
1680	85	38.1	38.1	38.1	38.1	41.0	33.0	35.9	35.9	35.9	35.9	38.3	31.8
1680	90	40.8	40.8	40.8	40.8	41.4	41.4	38.5	38.5	38.5	38.5	38.8	38.8
1920	75	33.9	33.9	36.5	27.4	40.3	15.6	31.7	31.7	33.9	26.1	37.3	14.4
1920	80	36.7	36.7	37.1	37.1	41.0	25.5	34.4	34.4	34.6	34.6	38.2	24.2
1920	85	39.5	39.5	39.5	39.5	41.5	36.0	37.1	37.1	37.1	37.1	38.7	34.7
1920	90	42.3	42.3	42.3	42.3	42.3	42.3	39.9	39.9	39.9	39.9	40.0	40.0
2100	75	34.6	34.6	36.8	28.8	40.5	16.0	32.3	32.3	34.1	27.4	37.4	14.8
2100	80	37.5	37.5	37.6	37.6	41.3	27.8	35.1	35.1	35.1	35.1	38.4	25.3
2100	85	40.3	40.3	40.4	40.4	41.8	38.1	37.9	37.9	37.9	37.9	39.0	36.8
2100	90	43.2	43.2	43.3	43.3	43.3	43.3	40.7	40.7	40.8	40.8	40.8	40.8

**Notes:**

1. All capacities shown are gross and have not considered indoor fan heat. To obtain **NET** cooling capacity subtract indoor fan heat. For indoor fan heat formula, refer to appropriate airflow table notes.
2. MBh = Total Gross Capacity
3. SHC = Sensible Heat Capacity



## Gross Cooling Capacities

**Table 23. Gross cooling capacities 6 tons high efficiency - stage 2 - three phase W/DHC074H3,4,W**

cfm	Ent DB (°F)	Ambient Temperature (°F)						Ambient Temperature (°F)					
		85						95					
		Entering Wet Bulb (°F)						Entering Wet Bulb (°F)					
		61		67		73		61		67		73	
		MBh	SHC	MBh	SHC	MBh	SHC	MBh	SHC	MBh	SHC	MBh	SHC
960	75	38.1	29.8	42.9	23.6	48.0	17.1	35.8	28.5	40.4	22.3	45.2	15.9
	80	38.0	34.7	43.0	28.9	48.1	22.5	35.8	33.4	40.5	27.7	45.2	21.2
	85	37.8	37.8	43.0	34.1	48.1	27.8	36.1	36.1	40.5	32.9	45.4	26.6
	90	40.0	40.0	43.0	39.0	48.2	33.1	38.2	38.2	40.5	37.8	45.5	31.9
1200	75	39.8	33.4	44.7	25.9	49.8	17.8	37.3	32.1	42.0	24.6	46.7	16.5
	80	39.9	39.8	44.9	32.5	49.9	24.5	37.5	37.5	42.1	31.2	46.9	23.2
	85	41.5	41.5	44.9	38.8	50.0	31.1	39.5	39.5	42.2	37.4	47.0	29.9
	90	44.0	44.0	45.0	45.0	50.2	37.8	41.9	41.9	42.4	42.4	47.1	36.5
1440	75	41.1	37.1	46.0	28.1	50.9	18.3	38.4	35.7	43.0	26.8	47.7	17.0
	80	41.7	41.7	46.1	36.1	51.1	26.4	39.5	39.5	43.2	34.3	48.0	25.1
	85	44.4	44.4	46.3	43.5	51.3	34.4	42.1	42.1	43.4	42.1	48.2	33.1
	90	47.1	47.1	47.2	47.2	51.4	41.9	44.7	44.7	44.8	44.8	48.3	40.5
1680	75	42.1	40.7	46.9	30.3	51.7	18.9	39.3	39.2	43.8	28.9	48.4	17.5
	80	43.8	43.8	47.1	39.1	52.0	28.3	41.4	41.4	44.0	37.6	48.7	26.9
	85	46.7	46.7	47.4	47.4	52.2	37.6	44.1	44.1	44.5	44.5	48.9	36.3
	90	49.5	49.5	49.6	49.6	52.4	46.2	46.9	46.9	47.0	47.0	49.2	44.8
1920	75	42.9	42.9	47.5	32.4	52.4	19.4	40.1	40.1	44.3	31.0	48.9	18.0
	80	45.5	45.5	47.8	42.3	52.7	30.1	42.9	42.9	44.6	40.8	49.3	28.7
	85	48.5	48.5	48.6	48.6	52.9	40.2	45.8	45.8	45.9	45.9	49.5	38.7
	90	51.5	51.5	51.6	51.6	53.3	50.6	48.7	48.7	48.8	48.8	49.9	49.1
2100	75	43.6	43.6	47.9	34.0	52.7	19.8	40.9	40.9	44.6	32.5	49.2	18.4
	80	46.6	46.6	48.3	44.8	53.1	31.5	43.9	43.9	45.0	43.2	49.6	30.1
	85	49.7	49.7	49.8	49.8	53.4	42.4	46.9	46.9	46.9	46.9	49.9	40.9
	90	52.8	52.8	52.8	52.8	53.8	53.8	49.9	49.9	49.9	49.9	50.5	50.5

**Notes:**

1. All capacities shown are gross and have not considered indoor fan heat. To obtain **NET** cooling capacity subtract indoor fan heat. For indoor fan heat formula, refer to appropriate airflow table notes.
2. MBh = Total Gross Capacity
3. SHC = Sensible Heat Capacity



## Gross Cooling Capacities

**Table 24. Gross cooling capacities 6 tons - full load - three phase W/DHC074H3,4,W**

cfm	Ent DB (°F)	Ambient Temperature (°F)						Ambient Temperature (°F)						Ambient Temperature (°F)					
		85						95						105					
		Entering Wet Bulb (°F)						Entering Wet Bulb (°F)						Entering Wet Bulb (°F)					
		61		67		73		61		67		73		61		67		73	
	MBh	SHC	MBh	SHC	MBh	SHC	MBh	SHC	MBh	SHC	MBh	SHC	MBh	SHC	MBh	SHC	MBh	SHC	
1920	75	72.1	56.8	80.7	44.8	89.7	32.2	68.0	54.7	76.0	42.6	84.5	30.0	63.6	52.4	71.2	40.4	79.0	27.8
	80	72.3	66.7	80.8	54.9	89.8	42.4	68.3	64.5	76.2	52.8	84.6	40.3	64.0	62.3	71.4	50.5	79.1	38.0
	85	73.6	73.6	80.9	65.0	89.9	52.6	70.2	70.2	76.4	62.9	84.7	50.4	66.6	66.6	71.5	60.6	79.3	48.2
	90	77.7	77.7	81.2	74.8	90.0	62.7	74.2	74.2	76.7	72.7	84.9	60.6	70.5	70.5	72.0	70.4	79.4	58.3
2160	75	73.8	60.6	82.4	47.0	91.4	32.8	69.5	58.4	77.5	44.7	85.9	30.6	64.9	56.1	72.4	42.4	80.2	28.3
	80	74.3	71.7	82.5	58.4	91.5	44.3	70.1	69.4	77.7	56.1	86.1	42.1	65.7	65.7	72.6	53.8	80.4	39.8
	85	77.0	77.0	82.7	69.7	91.6	55.7	73.3	73.3	78.0	67.5	86.2	53.5	69.4	69.4	72.9	64.9	80.5	51.2
	90	81.4	81.4	83.3	80.8	91.8	67.2	77.6	77.6	78.7	78.6	86.4	64.9	73.5	73.5	73.9	73.9	80.7	62.6
2400	75	75.2	64.3	83.8	49.1	92.8	33.3	70.7	62.0	78.7	46.8	87.1	31.1	66.0	59.3	73.4	44.5	81.2	28.7
	80	76.1	76.1	84.0	61.8	92.9	46.1	71.8	71.8	78.9	59.5	87.2	43.8	67.6	67.6	73.6	57.1	81.3	41.5
	85	80.0	80.0	84.3	74.1	93.1	58.8	76.0	76.0	79.3	71.8	87.4	56.6	71.8	71.8	74.1	69.4	81.5	54.2
	90	84.5	84.5	85.3	85.3	93.2	71.5	80.4	80.4	80.6	80.6	87.6	69.3	76.1	76.1	76.2	76.2	81.8	66.9
2640	75	76.4	67.6	84.9	51.2	93.9	33.9	71.8	65.2	79.7	48.8	88.0	31.5	66.9	62.7	74.2	46.4	81.9	29.2
	80	77.8	77.8	85.1	65.1	94.0	47.9	73.8	73.8	79.9	62.8	88.2	45.6	69.5	69.5	74.5	60.4	82.1	43.2
	85	82.5	82.5	85.7	78.7	94.2	61.9	78.4	78.4	80.6	76.3	88.4	59.6	73.9	73.9	75.2	73.8	82.3	57.2
	90	87.3	87.3	87.3	87.3	94.5	75.9	82.9	82.9	83.0	83.0	88.7	73.6	78.3	78.3	78.4	78.4	82.6	70.7
2880	75	77.5	71.1	85.9	53.2	94.8	34.4	72.7	68.7	80.5	50.8	88.8	32.0	67.7	66.2	74.8	48.4	82.5	29.6
	80	79.9	79.9	86.1	68.4	95.0	49.7	75.7	75.7	80.8	66.1	89.0	47.3	71.2	71.2	75.2	63.6	82.7	44.9
	85	84.8	84.8	86.9	83.2	95.2	65.0	80.4	80.4	81.7	80.8	89.2	62.6	75.7	75.7	76.2	76.2	82.9	60.2
	90	89.7	89.7	89.8	89.8	95.5	80.2	85.1	85.1	85.2	85.2	89.6	77.4	80.2	80.2	80.3	80.3	83.4	74.9
cfm	Ent DB (°F)	Ambient Temperature (°F)						Ambient Temperature (°F)											
		115						125											
		Entering Wet Bulb (°F)						Entering Wet Bulb (°F)											
		61		67		73		61		67		73							
	MBh	SHC	MBh	SHC	MBh	SHC	MBh	SHC	MBh	SHC	MBh	SHC							
1920	75	59.1	50.2	66.1	38.1	73.3	25.5	54.3	47.5	60.7	35.7	67.2	23.1						
	80	59.6	59.6	66.3	48.2	73.4	35.7	55.1	55.1	60.9	45.8	67.3	33.3						
	85	62.8	62.8	66.5	58.1	73.6	45.9	58.7	58.7	61.2	55.6	67.5	43.5						
	90	66.5	66.5	67.1	67.1	73.8	56.0	62.2	62.2	62.3	62.3	67.7	53.6						
2160	75	60.2	53.4	67.1	40.1	74.3	25.9	55.2	50.9	61.5	37.6	67.9	23.5						
	80	61.4	61.4	67.3	51.5	74.4	37.4	57.1	57.1	61.7	49.0	68.0	35.0						
	85	65.3	65.3	67.7	62.5	74.6	48.9	60.8	60.8	62.2	60.0	68.2	46.4						
	90	69.2	69.2	69.3	69.3	74.8	60.3	64.4	64.4	64.6	64.6	68.5	57.8						
2400	75	61.1	56.8	67.9	42.0	75.0	26.3	56.0	54.2	62.1	39.5	68.4	23.8						
	80	63.4	63.4	68.1	54.7	75.1	39.1	58.8	58.8	62.3	52.2	68.6	36.6						
	85	67.4	67.4	68.8	66.9	75.3	51.8	62.6	62.6	63.1	63.1	68.8	49.3						
	90	71.4	71.4	71.5	71.5	75.6	64.5	66.3	66.3	66.4	66.4	69.1	61.5						
2640	75	61.9	60.2	68.5	44.0	75.5	26.7	56.6	56.6	62.5	41.4	68.7	24.2						
	80	65.1	65.1	68.8	57.9	75.7	40.8	60.2	60.2	62.8	54.9	68.9	38.2						
	85	69.2	69.2	69.7	69.7	75.9	54.7	64.1	64.1	64.2	64.2	69.1	52.2						
	90	73.3	73.3	73.4	73.4	76.3	68.2	67.9	67.9	68.0	68.0	69.7	65.5						
2880	75	62.6	62.6	69.0	45.9	75.9	27.1	57.3	57.3	62.8	43.3	69.0	24.5						
	80	66.5	66.5	69.4	60.6	76.2	42.4	61.4	61.4	63.3	57.9	69.2	39.8						
	85	70.7	70.7	70.8	70.8	76.4	57.7	65.4	65.4	65.4	65.4	69.5	55.1						
	90	74.9	74.9	75.0	75.0	77.0	72.3	69.2	69.2	69.2	69.2	70.2	69.5						

**Notes:**

1. All capacities shown are gross and have not considered indoor fan heat. To obtain **NET** cooling capacity subtract indoor fan heat. For indoor fan heat formula, refer to appropriate airflow table notes.
2. MBh = Total Gross Capacity
3. SHC = Sensible Heat Capacity





## Gross Cooling Capacities

**Table 25. Gross cooling capacities 7.5 tons high efficiency - stage 1 - three phase W/DHC092H3,4,W**

cfm	Ent DB (°F)	Ambient Temperature (°F)						Ambient Temperature (°F)					
		85						95					
		Entering Wet Bulb (°F)						Entering Wet Bulb (°F)					
		61		67		73		61		67		73	
		MBh	SHC	MBh	SHC	MBh	SHC	MBh	SHC	MBh	SHC	MBh	SHC
1200	75	33.1	29.8	37.2	23.1	41.5	15.1	31.2	28.8	35.2	22.1	39.2	14.1
	80	32.9	32.9	37.5	29.7	42.0	21.8	31.0	31.0	35.5	27.8	39.8	20.9
	85	34.2	34.2	37.8	35.3	42.3	28.5	32.7	32.7	35.7	34.2	40.1	27.6
	90	36.5	36.5	37.5	37.5	42.6	34.2	34.9	34.9	35.5	35.5	40.4	33.1
1500	75	34.2	34.2	38.4	25.8	42.5	15.8	32.2	32.2	36.2	24.8	40.0	14.7
	80	34.8	34.8	38.8	32.9	43.3	24.3	33.1	33.1	36.6	31.8	40.9	23.2
	85	37.3	37.3	39.0	39.0	43.7	32.7	35.5	35.5	36.8	36.8	41.3	31.7
	90	39.8	39.8	39.8	39.8	44.0	39.5	38.0	38.0	38.1	38.1	41.7	38.4
1800	75	35.0	35.0	39.2	28.5	43.2	16.4	32.9	32.9	36.9	27.4	40.5	15.3
	80	36.9	36.9	39.7	36.8	44.2	26.6	35.0	35.0	37.4	35.6	41.6	25.6
	85	39.6	39.6	40.1	40.1	44.6	36.7	37.7	37.7	37.8	37.8	42.2	33.9
	90	42.3	42.3	42.4	42.4	45.0	44.8	40.3	40.3	40.4	40.4	42.6	42.6
2100	75	35.8	35.8	39.8	29.5	43.6	17.1	33.7	33.7	37.4	28.2	40.8	15.9
	80	38.5	38.5	40.4	40.4	44.8	29.0	36.5	36.5	38.0	38.0	42.2	27.9
	85	41.4	41.4	41.5	41.5	45.4	38.6	39.3	39.3	39.4	39.4	42.8	37.4
	90	44.3	44.3	44.4	44.4	45.8	45.8	42.2	42.2	42.2	42.2	43.3	43.3
2400	75	36.9	36.9	40.3	31.6	43.9	17.7	34.8	34.8	37.8	30.2	41.0	16.5
	80	39.9	39.9	41.0	41.0	45.3	31.3	37.7	37.7	38.5	38.5	42.6	30.2
	85	42.9	42.9	42.9	42.9	46.0	42.1	40.7	40.7	40.7	40.7	43.3	40.8
	90	46.0	46.0	46.0	46.0	46.5	46.5	43.7	43.7	43.7	43.7	43.9	43.9
2625	75	37.6	37.6	40.6	33.2	44.0	18.1	35.4	35.4	38.0	31.7	41.0	16.9
	80	40.7	40.7	41.3	41.3	45.6	33.1	38.4	38.4	38.8	38.8	42.8	31.9
	85	43.8	43.8	43.9	43.9	46.3	44.7	41.5	41.5	41.5	41.5	43.6	43.4
	90	47.0	47.0	47.0	47.0	47.1	47.1	44.6	44.6	44.6	44.6	44.5	44.5

**Notes:**

1. All capacities shown are gross and have not considered indoor fan heat. To obtain **NET** cooling capacity subtract indoor fan heat. For indoor fan heat formula, refer to appropriate airflow table notes.
2. MBh = Total Gross Capacity
3. SHC = Sensible Heat Capacity



## Gross Cooling Capacities

**Table 26. Gross cooling capacities 7.5 tons high efficiency - stage 2 - three phase W/DHC092H3,4,W**

cfm	Ent DB (°F)	Ambient Temperature (°F)						Ambient Temperature (°F)					
		85						95					
		Entering Wet Bulb (°F)						Entering Wet Bulb (°F)					
		61		67		73		61		67		73	
		MBh	SHC	MBh	SHC	MBh	SHC	MBh	SHC	MBh	SHC	MBh	SHC
1200	75	48.2	37.6	54.2	29.9	60.7	21.9	45.9	36.3	51.6	28.6	57.7	20.6
	80	48.4	43.7	54.5	36.6	61.0	28.6	46.0	42.4	51.9	35.3	58.1	27.3
	85	48.6	48.6	54.6	43.2	61.2	35.3	46.7	46.7	52.0	41.5	58.4	34.0
	90	51.5	51.5	54.7	49.2	61.4	42.0	49.5	49.5	52.2	47.9	58.6	40.7
1500	75	50.6	42.0	56.7	32.9	63.0	22.8	48.0	40.6	53.8	31.5	59.8	21.4
	80	51.0	50.1	57.0	41.2	63.6	31.2	48.5	48.5	54.1	39.8	60.4	29.9
	85	53.3	53.3	57.2	48.8	63.9	39.6	51.1	51.1	54.4	47.4	60.8	38.2
	90	56.6	56.6	57.7	56.9	64.2	47.9	54.3	54.3	55.0	55.0	61.0	46.0
1800	75	52.3	46.5	58.4	35.7	64.6	23.5	49.5	45.0	55.3	34.3	61.1	22.1
	80	53.4	53.4	58.7	44.9	65.4	33.7	51.1	51.1	55.7	43.4	62.0	32.3
	85	57.0	57.0	59.2	54.6	65.8	43.7	54.5	54.5	56.2	53.1	62.4	42.3
	90	60.6	60.6	60.7	60.7	66.1	52.8	58.1	58.1	58.2	58.2	62.8	51.3
2100	75	53.7	51.0	59.6	38.4	65.7	24.2	50.8	49.4	56.3	37.0	62.1	22.7
	80	56.2	56.2	60.1	49.0	66.7	36.1	54	53.6	56.9	47.4	63.1	34.6
	85	60.0	60.0	60.9	60.4	67.1	47.8	57.3	57.3	57.8	57.8	63.6	45.3
	90	63.8	63.8	63.9	63.9	67.7	58.2	61.1	61.1	61.2	61.2	64.2	56.6
2400	75	54.9	54.9	60.5	41.1	66.5	24.9	51.9	51.9	57.0	38.4	62.7	23.4
	80	58.4	58.4	61.2	53.0	67.7	38.4	55.6	55.6	57.9	51.3	63.9	36.9
	85	62.4	62.4	62.5	62.5	68.2	50.5	59.5	59.5	59.6	59.6	64.5	48.8
	90	66.5	66.5	66.6	66.6	69.0	63.5	63.5	63.5	63.6	63.6	65.4	61.8
2625	75	55.8	55.8	61.0	41.8	67.0	25.4	52.8	52.8	57.6	40.0	63.0	23.8
	80	59.8	59.8	61.9	55.9	68.3	40.2	56.9	56.9	58.5	54.2	64.4	38.6
	85	64.0	64.0	64.1	64.1	68.9	53.2	61.0	61.0	61.0	61.0	65.1	51.5
	90	68.3	68.3	68.3	68.3	69.8	67.4	65.1	65.1	65.2	65.2	66.1	65.8

**Notes:**

1. All capacities shown are gross and have not considered indoor fan heat. To obtain **NET** cooling capacity subtract indoor fan heat. For indoor fan heat formula, refer to appropriate airflow table notes.
2. MBh = Total Gross Capacity
3. SHC = Sensible Heat Capacity

## Gross Cooling Capacities

**Table 27. Gross cooling capacities 7.5 tons high efficiency - full load - three phase W/DHC092H3,4,W**

cfm	Ent DB (°F)	Ambient Temperature (°F)						Ambient Temperature (°F)						Ambient Temperature (°F)					
		85						95						105					
		Entering Wet Bulb (°F)						Entering Wet Bulb (°F)						Entering Wet Bulb (°F)					
		61		67		73		61		67		73		61		67		73	
	MBh	SHC	MBh	SHC	MBh	SHC	MBh	SHC	MBh	SHC	MBh	SHC	MBh	SHC	MBh	SHC	MBh	SHC	
2400	75	87.8	71.0	97.6	55.3	108.0	39.0	83.3	68.7	92.6	53.0	102.3	36.7	78.5	65.5	87.4	50.6	96.4	34.4
	80	88.4	83.0	98.0	68.4	108.3	52.2	84.0	80.6	93.0	66.1	102.8	49.9	79.5	78.1	87.8	63.7	97.0	47.6
	85	90.6	90.6	98.3	81.4	108.7	65.3	86.8	86.8	93.4	79.1	103.2	63.0	82.9	82.9	88.2	76.7	97.5	60.7
	90	95.6	95.6	99.0	93.3	109.1	78.4	91.7	91.7	94.2	90.9	103.6	76.1	87.6	87.6	89.2	88.4	97.8	73.8
2700	75	89.6	74.9	99.6	58.1	109.9	39.8	85.0	72.4	94.3	55.7	103.9	37.4	80.1	69.8	88.9	53.3	97.8	35.0
	80	90.7	89.2	100.0	72.8	110.3	54.6	86.2	86.2	94.8	70.4	104.5	52.2	81.5	81.5	89.4	68.0	98.5	49.8
	85	94.5	94.5	100.4	87.4	110.8	69.4	90.4	90.4	95.3	83.8	105.0	67.0	86.2	86.2	90.0	81.2	99.0	64.6
	90	99.8	99.8	101.5	100.7	111.2	84.1	95.6	95.6	96.6	96.6	105.4	81.7	91.2	91.2	91.5	91.5	99.4	79.3
3000	75	91.3	79.3	101.2	60.8	111.3	40.4	86.5	76.7	95.7	58.4	105.2	38.0	81.5	74.0	90.1	55.9	98.8	35.6
	80	92.8	92.8	101.7	77.1	112.0	56.9	88.3	88.3	96.2	74.7	105.9	54.5	83.8	83.8	90.6	72.2	99.7	52.1
	85	97.9	97.9	102.3	92.0	112.5	73.4	93.5	93.5	97.0	89.4	106.5	71.0	89.0	89.0	91.5	86.7	100.3	68.5
	90	103.4	103.4	104.0	104.0	112.9	89.7	98.9	98.9	99.0	99.0	106.9	87.3	94.2	94.2	94.3	94.3	100.7	83.2
3300	75	92.8	83.6	102.5	63.5	112.5	41.1	87.8	81.0	96.9	61.0	106.2	38.7	82.6	78.2	91.0	58.4	99.7	36.1
	80	95.0	95.0	103.0	81.4	113.3	59.3	90.7	90.7	97.4	78.9	107.1	56.8	86.0	86.0	91.6	74.8	100.6	54.3
	85	100.8	100.8	103.9	97.6	113.9	77.3	96.2	96.2	98.5	94.9	107.7	74.9	91.4	91.4	92.8	92.2	101.3	72.4
	90	106.6	106.6	106.5	106.5	114.4	93.7	101.8	101.8	101.9	101.9	108.2	91.1	96.8	96.8	96.9	96.9	101.9	88.3
3600	75	94.1	87.9	103.6	66.1	113.6	41.8	88.9	85.2	97.8	63.6	107.1	39.3	83.6	82.4	91.8	61.0	100.4	36.7
	80	97.5	97.5	104.2	84.2	114.5	61.6	92.8	92.8	98.4	81.4	108.1	59.1	88.0	88.0	92.5	78.6	101.4	56.5
	85	103.4	103.4	105.4	103.2	115.1	81.3	98.6	98.6	99.9	99.9	108.7	78.8	93.5	93.5	94.1	94.1	102.1	76.2
	90	109.3	109.3	109.5	109.5	115.7	98.9	104.3	104.3	104.4	104.4	109.4	96.2	99.0	99.0	99.1	99.1	102.9	93.4
cfm	Ent DB (°F)	Ambient Temperature (°F)						Ambient Temperature (°F)											
		115						125											
		Entering Wet Bulb (°F)						Entering Wet Bulb (°F)											
		61		67		73		61		67		73							
	MBh	SHC	MBh	SHC	MBh	SHC	MBh	SHC	MBh	SHC	MBh	SHC							
2400	75	73.7	62.9	81.9	48.2	90.2	31.9	68.5	60.1	76.1	45.6	83.6	29.4						
	80	74.7	74.7	82.4	61.3	90.9	45.1	69.8	69.8	76.6	58.7	84.4	42.6						
	85	78.7	78.7	82.9	73.1	91.4	58.3	74.1	74.1	77.2	70.3	84.9	55.7						
	90	83.3	83.3	84.0	84.0	91.8	71.3	78.5	78.5	78.6	78.6	85.2	68.8						
2700	75	75.1	67.1	83.2	50.8	91.3	32.5	69.7	64.2	77.1	48.2	84.5	29.9						
	80	76.8	76.8	83.7	65.5	92.1	47.4	72.1	72.1	77.6	61.5	85.3	44.7						
	85	81.6	81.6	84.4	78.5	92.7	62.1	76.7	76.7	78.5	75.7	85.9	59.5						
	90	86.4	86.4	86.6	86.6	93.1	75.4	81.3	81.3	81.4	81.4	86.4	72.6						
3000	75	76.2	71.2	84.2	53.3	92.2	33.0	70.7	68.3	77.9	50.6	85.1	30.4						
	80	79.2	79.2	84.7	68.2	93.1	49.6	74.2	74.2	78.5	65.2	86.1	46.9						
	85	84.2	84.2	85.7	84.0	93.7	66.0	78.9	78.9	79.7	79.7	86.7	63.3						
	90	89.1	89.1	89.3	89.3	94.3	80.5	83.6	83.6	83.7	83.7	87.3	77.5						
3300	75	77.2	75.4	84.9	55.8	92.9	33.6	71.5	71.5	78.5	53.1	85.6	30.8						
	80	81.1	81.1	85.6	71.9	93.9	51.7	75.9	75.9	79.2	68.9	86.6	49.0						
	85	86.3	86.3	87.0	87.0	94.5	69.8	80.7	80.7	80.9	80.9	87.2	65.1						
	90	91.4	91.4	91.5	91.5	95.2	85.5	85.5	85.5	85.6	85.6	88.1	82.4						
3600	75	78.1	78.1	85.6	58.3	93.4	34.1	72.4	72.4	78.9	55.5	85.9	31.3						
	80	82.8	82.8	86.3	75.6	94.5	53.9	77.3	77.3	79.8	72.5	87.1	51.1						
	85	88.1	88.1	88.2	88.2	95.1	71.6	82.3	82.3	82.4	82.4	87.7	68.4						
	90	93.3	93.3	93.5	93.5	96.1	90.4	87.2	87.2	87.3	87.3	88.8	87.3						

**Notes:**

1. All capacities shown are gross and have not considered indoor fan heat. To obtain **NET** cooling capacity subtract indoor fan heat. For indoor fan heat formula, refer to appropriate airflow table notes.
2. MBh = Total Gross Capacity
3. SHC = Sensible Heat Capacity



## Gross Cooling Capacities

**Table 28. Gross cooling capacities 8.5 tons high efficiency - stage 1 - three phase W/DHC102H3,4,W**

cfm	Ent DB (°F)	Ambient Temperature (°F)						Ambient Temperature (°F)					
		85						95					
		Entering Wet Bulb (°F)						Entering Wet Bulb (°F)					
		61		67		73		61		67		73	
		MBh	SHC	MBh	SHC	MBh	SHC	MBh	SHC	MBh	SHC	MBh	SHC
1360	75	40.9	36.2	46.2	27.7	52.0	18.7	38.0	34.7	43.2	26.3	48.7	17.3
	80	41.8	41.8	46.3	35.2	52.2	26.3	39.4	39.4	43.3	33.8	48.9	24.9
	85	44.6	44.6	46.5	42.4	52.3	33.8	42.3	42.3	43.5	41.0	49.0	32.5
	90	47.5	47.5	47.7	47.7	52.4	41.3	45.1	45.1	45.2	45.2	49.1	40.0
1700	75	42.6	41.5	47.8	30.8	53.6	19.5	39.6	39.6	44.5	29.4	50.0	18.1
	80	45.1	45.1	48.0	40.0	53.8	29.0	42.5	42.5	44.8	38.5	50.3	27.6
	85	48.3	48.3	48.6	48.6	54.0	38.5	45.7	45.7	45.8	45.8	50.5	37.1
	90	51.6	51.6	51.7	51.7	54.3	47.6	48.9	48.9	49.0	49.0	50.8	46.2
2040	75	44.3	44.3	48.8	33.9	54.6	20.3	41.5	41.5	45.4	32.4	50.9	18.9
	80	47.7	47.7	49.2	44.8	55.0	31.7	44.9	44.9	45.9	43.3	51.3	30.3
	85	51.2	51.2	51.3	51.3	55.2	43.1	48.3	48.3	48.4	48.4	51.5	41.2
	90	54.7	54.7	54.8	54.8	55.8	53.9	51.7	51.7	51.8	51.8	52.3	52.3
2380	75	46.1	46.1	49.6	36.9	55.4	21.1	43.2	43.2	46.0	34.9	51.5	19.6
	80	49.8	49.8	50.3	49.6	55.8	34.4	46.7	46.7	46.9	46.9	51.9	32.9
	85	53.5	53.5	53.5	53.5	56.1	47.1	50.3	50.3	50.4	50.4	52.4	45.6
	90	57.2	57.2	57.3	57.3	57.3	57.3	54.0	54.0	54.1	54.1	54.1	54.1
2720	75	47.6	47.6	50.2	39.4	55.9	21.8	44.4	44.4	46.5	37.7	52.0	20.3
	80	51.4	51.4	51.4	51.4	56.3	37.0	48.2	48.2	48.2	48.2	52.4	35.5
	85	55.3	55.3	55.3	55.3	56.9	51.5	52.0	52.0	52.0	52.0	53.1	49.9
	90	59.2	59.2	59.3	59.3	59.3	59.3	55.8	55.8	55.8	55.8	55.9	55.9
2975	75	48.5	48.5	50.5	41.5	56.3	22.4	45.2	45.2	46.8	39.8	52.2	20.8
	80	52.4	52.4	52.5	52.5	56.7	39.0	49.1	49.1	49.1	49.1	52.7	36.8
	85	56.4	56.4	56.5	56.5	57.4	54.7	53.0	53.0	53.0	53.0	53.6	53.1
	90	60.5	60.5	60.5	60.5	60.6	60.6	56.9	56.9	57.0	57.0	57.0	57.0

**Notes:**

1. All capacities shown are gross and have not considered indoor fan heat. To obtain **NET** cooling capacity subtract indoor fan heat. For indoor fan heat formula, refer to appropriate airflow table notes.
2. MBh = Total Gross Capacity
3. SHC = Sensible Heat Capacity

## Gross Cooling Capacities

**Table 29. Gross cooling capacities 8.5 tons high efficiency - stage 2 - three phase W/DHC102H3,4,W**

cfm	Ent DB (°F)	Ambient Temperature (°F)						Ambient Temperature (°F)					
		85						95					
		Entering Wet Bulb (°F)						Entering Wet Bulb (°F)					
		61		67		73		61		67		73	
		MBh	SHC	MBh	SHC	MBh	SHC	MBh	SHC	MBh	SHC	MBh	SHC
1360	75	50.6	40.8	57.2	32.0	64.2	22.9	47.7	39.2	53.9	30.5	60.6	21.4
	80	50.7	48.2	57.2	39.5	64.2	30.5	47.9	46.7	54.0	38.0	60.7	29.0
	85	52.4	52.4	57.2	47.0	64.2	38.0	50.1	50.1	54.0	45.5	60.7	36.6
	90	55.6	55.6	57.3	54.4	64.3	45.5	53.1	53.1	54.2	52.9	60.8	44.1
1700	75	52.9	46.3	59.5	35.3	66.6	23.9	49.7	44.8	56.0	33.7	62.8	22.3
	80	53.8	53.8	59.5	44.7	66.7	33.4	51.1	51.1	56.1	43.1	62.8	31.8
	85	57.2	57.2	59.7	54.0	66.7	42.8	54.5	54.5	56.3	52.4	62.9	41.2
	90	60.7	60.7	60.9	60.9	66.8	52.2	58.0	58.0	58.1	58.1	63.0	50.6
2040	75	54.6	51.7	61.1	38.4	68.2	24.7	51.3	50.1	57.4	36.8	64.2	23.1
	80	57.2	57.2	61.2	49.7	68.3	36.1	54.3	54.3	57.5	48.1	64.2	34.5
	85	61.0	61.0	61.8	61.0	68.4	47.4	58.0	58.0	58.3	58.3	64.4	45.8
	90	64.8	64.8	64.9	64.9	68.6	58.7	61.7	61.7	61.8	61.8	64.6	57.1
2380	75	56.1	56.1	62.2	41.5	69.4	25.5	52.9	52.9	58.3	39.8	65.1	23.9
	80	59.9	59.9	62.5	54.7	69.5	38.8	56.7	56.7	58.7	53.0	65.2	37.1
	85	64.0	64.0	63.8	63.8	69.6	52.0	60.7	60.7	60.8	60.8	65.4	50.3
	90	68.1	68.1	68.2	68.2	70.1	65.1	64.7	64.7	64.8	64.8	66.0	63.5
2720	75	57.9	57.9	63.0	44.5	70.3	26.3	54.7	54.7	59.0	42.8	65.9	24.6
	80	62.1	62.1	63.6	59.5	70.4	41.4	58.8	58.8	59.7	57.8	66.0	39.7
	85	66.4	66.4	66.1	66.1	70.6	56.5	62.9	62.9	63.0	63.0	66.3	54.8
	90	70.7	70.7	70.8	70.8	71.5	71.5	67.0	67.0	67.1	67.1	67.3	67.3
2975	75	59.2	59.2	63.6	46.8	70.8	26.8	55.8	55.8	59.4	45.0	66.3	25.1
	80	63.5	63.5	64.3	63.2	70.9	43.4	60.0	60.0	60.4	60.4	66.4	41.7
	85	68.0	68.0	68.0	68.0	71.3	60.0	64.3	64.3	64.3	64.3	66.8	58.2
	90	72.4	72.4	71.0	71.0	72.6	72.6	68.6	68.6	68.6	68.6	68.7	68.7

**Notes:**

1. All capacities shown are gross and have not considered indoor fan heat. To obtain **NET** cooling capacity subtract indoor fan heat. For indoor fan heat formula, refer to appropriate airflow table notes.
2. MBh = Total Gross Capacity
3. SHC = Sensible Heat Capacity



## Gross Cooling Capacities

**Table 30. Gross cooling capacities 8.5 tons high efficiency - full load - three phase W/DHC102H3,4,W**

cfm	Ent DB (°F)	Ambient Temperature (°F)						Ambient Temperature (°F)						Ambient Temperature (°F)					
		85						95						105					
		Entering Wet Bulb (°F)						Entering Wet Bulb (°F)						Entering Wet Bulb (°F)					
		61		67		73		61		67		73		61		67		73	
	MBh	SHC	MBh	SHC	MBh	SHC	MBh	SHC	MBh	SHC	MBh	SHC	MBh	SHC	MBh	SHC	MBh	SHC	
2720	75	97.4	79.6	108.2	61.7	119.6	43.1	92.1	76.9	102.3	59.0	113.0	40.5	86.5	74.2	96.1	56.3	106.2	37.8
	80	98.2	93.9	108.5	76.5	119.8	58.1	93.1	91.2	102.6	73.8	113.3	55.4	87.7	87.7	96.5	71.1	106.5	52.7
	85	101.7	101.7	108.8	91.3	120.1	72.9	97.2	97.2	103.0	88.6	113.6	70.3	92.4	92.4	97.0	85.9	106.8	67.6
	90	107.3	107.3	109.7	105.5	120.3	87.7	102.6	102.6	104.1	102.8	113.8	85.1	97.7	97.7	98.3	98.3	107.1	82.4
3060	75	99.5	85.0	110.2	64.8	121.6	43.9	94.0	82.3	104.1	62.1	114.8	41.2	88.2	79.5	97.7	59.3	107.6	38.5
	80	100.8	100.8	110.5	81.4	121.9	60.7	95.6	95.6	104.4	78.7	115.0	58.0	90.5	90.5	98.0	75.9	108.0	55.3
	85	105.9	105.9	111.1	98.1	122.2	77.5	101.1	101.1	105.1	94.7	115.4	74.8	96.0	96.0	98.8	91.8	108.3	72.0
	90	111.8	111.8	112.7	112.7	122.5	94.1	106.8	106.8	107.0	107.0	115.7	91.5	101.4	101.4	101.6	101.6	108.7	88.7
3400	75	101.3	90.4	111.9	67.8	123.2	44.7	95.6	86.8	105.5	65.1	116.1	42.0	89.6	83.8	98.9	62.2	108.7	39.2
	80	103.4	103.4	112.2	86.3	123.5	63.4	98.5	98.5	105.9	83.6	116.5	60.6	93.2	93.2	99.3	80.7	109.2	57.8
	85	109.5	109.5	113.1	104.1	123.9	81.9	104.4	104.4	106.9	101.2	116.8	79.2	98.9	98.9	100.5	98.3	109.5	76.4
	90	115.7	115.7	115.7	115.7	124.3	100.5	110.3	110.3	110.5	110.5	117.3	97.8	104.6	104.6	104.8	104.8	110.1	95.0
3740	75	102.8	94.8	113.3	70.9	124.5	45.4	97.0	91.8	106.7	68.0	117.2	42.7	90.9	88.7	99.8	65.1	109.6	39.8
	80	106.4	106.4	113.7	91.2	124.9	66.0	101.1	101.1	107.2	88.4	117.6	63.2	95.6	95.6	100.4	85.5	110.1	60.3
	85	112.7	112.7	114.9	110.6	125.3	86.4	107.2	107.2	108.6	107.7	118.0	83.6	101.5	101.5	102.1	102.1	110.5	80.8
	90	119.0	119.0	119.2	119.2	125.8	106.9	113.3	113.3	113.5	113.5	118.7	104.1	107.3	107.3	107.5	107.5	111.3	100.1
4080	75	104.3	99.8	114.4	73.8	125.6	46.2	98.3	96.8	107.6	70.9	118.1	43.3	92.1	92.1	100.6	68.0	110.3	40.4
	80	108.9	108.9	114.9	96.1	126.0	68.6	103.4	103.4	108.2	93.2	118.6	65.7	97.7	97.7	101.3	89.1	110.9	62.8
	85	115.4	115.4	116.6	116.6	126.4	90.9	109.7	109.7	110.2	110.2	119.0	88.0	103.7	103.7	103.7	103.7	111.3	85.1
	90	121.9	121.9	122.1	122.1	127.2	113.2	115.9	115.9	116.1	116.1	119.9	109.1	109.7	109.7	109.8	109.8	112.4	106.0
cfm	Ent DB (°F)	Ambient Temperature (°F)						Ambient Temperature (°F)											
		115						125											
		Entering Wet Bulb (°F)						Entering Wet Bulb (°F)											
		61		67		73		61		67		73							
	MBh	SHC	MBh	SHC	MBh	SHC	MBh	SHC	MBh	SHC	MBh	SHC							
2720	75	80.7	71.3	89.7	53.5	99.0	35.0	74.5	67.7	82.8	50.5	91.2	32.1						
	80	82.3	82.3	90.0	68.3	99.3	49.9	77.0	77.0	83.1	65.3	91.6	47.0						
	85	87.4	87.4	90.6	82.4	99.6	64.8	81.8	81.8	83.8	79.3	91.9	61.9						
	90	92.4	92.4	92.6	92.6	100.0	79.6	86.6	86.6	86.8	86.8	92.3	76.7						
3060	75	82.2	75.7	90.9	56.4	100.1	35.6	75.8	72.5	83.8	53.4	92.0	32.6						
	80	85.2	85.2	91.3	73.0	100.5	52.4	79.6	79.6	84.2	70.0	92.5	49.4						
	85	90.5	90.5	92.3	88.8	100.9	69.2	84.6	84.6	85.4	85.4	92.9	66.2						
	90	95.8	95.8	95.9	95.9	101.4	85.9	89.5	89.5	89.7	89.7	93.4	81.9						
3400	75	83.5	80.7	91.9	59.3	101.0	36.3	77.0	77.0	84.5	56.2	92.7	33.2						
	80	87.7	87.7	92.4	77.8	101.5	54.9	81.7	81.7	85.1	73.7	93.3	51.9						
	85	93.2	93.2	93.9	93.9	101.9	73.5	86.9	86.9	87.0	87.0	93.6	70.5						
	90	98.6	98.6	98.7	98.7	102.5	91.0	91.9	91.9	92.1	92.1	94.5	87.8						
3740	75	84.7	84.7	92.7	62.1	101.7	36.9	78.1	78.1	85.1	59.0	93.2	33.8						
	80	89.8	89.8	93.3	81.4	102.2	57.4	83.5	83.5	85.8	78.1	93.8	54.3						
	85	95.4	95.4	95.5	95.5	102.7	77.8	88.8	88.8	88.9	88.9	94.2	74.7						
	90	100.9	100.9	101.1	101.1	103.6	96.9	93.9	93.9	94.0	94.0	95.4	93.6						
4080	75	85.8	85.8	93.3	64.9	102.2	37.5	79.5	79.5	85.5	61.7	93.6	34.3						
	80	91.6	91.6	94.2	85.9	102.8	59.9	84.9	84.9	86.5	82.4	94.2	56.7						
	85	97.3	97.3	97.4	97.4	103.3	82.2	90.3	90.3	90.4	90.4	94.7	79.0						
	90	102.9	102.9	103.1	103.1	104.6	102.8	95.6	95.6	95.7	95.7	96.2	96.2						

**Notes:**

1. All capacities shown are gross and have not considered indoor fan heat. To obtain **NET** cooling capacity subtract indoor fan heat. For indoor fan heat formula, refer to appropriate airflow table notes.
2. MBh = Total Gross Capacity
3. SHC = Sensible Heat Capacity

## Gross Cooling Capacities

**Table 31. Gross cooling capacities 10 tons high efficiency - stage 1 - three phase W/DHC120H3,4,W**

cfm	Ent DB (°F)	Ambient Temperature (°F)						Ambient Temperature (°F)					
		85						95					
		Entering Wet Bulb (°F)						Entering Wet Bulb (°F)					
		61		67		73		61		67		73	
		MBh	SHC	MBh	SHC	MBh	SHC	MBh	SHC	MBh	SHC	MBh	SHC
3200	75	50.7	42.7	57.6	32.9	64.8	22.4	46.9	40.5	53.5	30.8	60.3	20.3
	80	51.0	51.0	57.8	41.7	65.2	31.4	47.6	47.6	53.7	39.6	60.8	29.3
	85	54.4	54.4	57.9	50.2	65.4	40.3	51.2	51.2	53.9	48.0	61.1	38.2
	90	58.0	58.0	58.3	58.3	65.5	49.1	54.7	54.7	54.9	54.9	61.2	47.0
3600	75	52.9	49.0	59.8	36.7	67.0	23.5	48.9	46.7	55.4	34.5	62.2	21.4
	80	55.3	55.3	60.0	47.4	67.6	34.7	51.8	51.8	55.7	45.1	62.9	32.6
	85	59.3	59.3	60.5	58.3	67.9	45.8	55.7	55.7	56.3	56.0	63.2	43.7
	90	63.4	63.4	63.5	63.5	68.1	56.5	59.7	59.7	59.9	59.9	63.5	54.2
4000	75	54.7	54.7	61.3	40.4	68.4	24.5	50.8	50.8	56.7	38.1	63.4	22.3
	80	58.8	58.8	61.7	53.0	69.2	38.0	55.0	55.0	57.2	50.7	64.2	35.8
	85	63.2	63.2	63.3	63.3	69.5	51.3	59.3	59.3	59.4	59.4	64.6	48.4
	90	67.6	67.6	67.7	67.7	70.0	63.9	63.6	63.6	63.7	63.7	65.3	61.6
4400	75	57.0	57.0	62.3	43.3	69.4	25.4	53.0	53.0	57.5	40.8	64.1	23.2
	80	61.6	61.6	63.1	58.6	70.3	41.1	57.5	57.5	58.4	56.1	65.2	38.9
	85	66.2	66.2	66.3	66.3	70.8	55.9	62.0	62.0	62.1	62.1	65.7	53.4
	90	70.9	70.9	71.0	71.0	71.7	71.3	66.6	66.6	66.7	66.7	66.9	66.9
	75	59.0	59.0	63.2	46.5	69.9	26.3	54.7	54.7	58.2	43.9	64.4	24.0
	80	63.8	63.8	64.3	64.1	71.1	44.3	59.5	59.5	59.6	59.6	65.8	41.9
	85	68.7	68.7	68.8	68.8	71.8	60.9	64.3	64.3	64.3	64.3	66.6	58.4
	90	73.7	73.7	73.8	73.8	73.9	73.9	69.1	69.1	69.2	69.2	69.3	69.3
	75	60.2	60.2	63.7	48.9	70.2	27.0	55.8	55.8	58.6	46.2	64.6	24.6
	80	65.2	65.2	65.2	65.2	71.6	45.4	60.7	60.7	60.8	60.8	66.2	42.7
	85	70.3	70.3	70.4	70.4	72.5	64.6	65.6	65.6	65.7	65.7	67.2	62.1
	90	75.4	75.4	75.5	75.5	75.6	75.6	70.6	70.6	70.7	70.7	70.8	70.8

**Notes:**

1. All capacities shown are gross and have not considered indoor fan heat. To obtain **NET** cooling capacity subtract indoor fan heat. For indoor fan heat formula, refer to appropriate airflow table notes.
2. MBh = Total Gross Capacity
3. SHC = Sensible Heat Capacity



## Gross Cooling Capacities

**Table 32. Gross cooling capacities 10 tons high efficiency - stage 2 - three phase W/DHC120H3,4,W**

cfm	Ent DB (°F)	Ambient Temperature (°F)						Ambient Temperature (°F)					
		85						95					
		Entering Wet Bulb (°F)						Entering Wet Bulb (°F)					
		61		67		73		61		67		73	
		MBh	SHC	MBh	SHC	MBh	SHC	MBh	SHC	MBh	SHC	MBh	SHC
1600	75	57.4	46.0	64.5	35.6	72.1	24.9	53.7	43.8	60.5	33.5	67.7	22.8
	80	57.6	54.5	64.7	44.5	72.3	33.8	53.9	52.3	60.7	42.3	67.9	31.7
	85	59.5	59.5	64.7	53.2	72.5	42.7	56.4	56.4	60.7	51.1	68.0	40.6
	90	63.1	63.1	64.9	61.7	72.5	51.5	59.9	59.9	61.0	59.6	68.2	49.4
2000	75	59.9	52.2	67.1	39.5	74.7	26.0	56.0	49.9	62.7	37.2	69.8	23.8
	80	61.0	61.0	67.3	50.5	75.0	37.2	57.5	57.5	62.9	48.3	70.2	35.0
	85	64.9	64.9	67.6	61.2	75.2	48.3	61.4	61.4	63.3	58.9	70.4	46.1
	90	68.9	68.9	69.0	69.0	75.3	59.3	65.3	65.3	65.4	65.4	70.6	57.1
2400	75	61.8	58.4	68.8	43.2	76.4	27.0	57.6	56.0	64.2	40.8	71.3	24.7
	80	64.8	64.8	69.1	56.4	76.8	40.4	61.0	61.0	64.5	53.7	71.7	38.1
	85	69.1	69.1	69.8	69.1	77.0	53.7	65.2	65.2	65.3	65.3	72.0	51.5
	90	73.4	73.4	73.5	73.5	77.4	66.6	69.4	69.4	69.5	69.5	72.4	64.2
2800	75	63.4	63.4	70.0	46.8	77.5	27.9	59.4	59.4	65.2	44.4	72.2	25.6
	80	67.8	67.8	70.5	61.7	78.1	43.6	63.7	63.7	65.7	59.2	72.8	41.2
	85	72.4	72.4	72.5	72.5	78.4	59.1	68.2	68.2	68.3	68.3	73.1	56.8
	90	77.0	77.0	77.1	77.1	79.0	74.0	72.6	72.6	72.7	72.7	73.9	71.5
3200	75	65.5	65.5	71.0	50.3	78.4	28.8	61.3	61.3	65.9	47.9	72.9	26.4
	80	70.2	70.2	71.7	67.2	79.0	46.7	65.9	65.9	66.8	64.7	73.5	44.3
	85	75.1	75.1	75.2	75.2	79.5	63.8	70.6	70.6	70.7	70.7	74.0	61.3
	90	79.9	79.9	80.1	80.1	80.5	80.5	75.2	75.2	75.3	75.3	75.4	75.4
3500	75	66.9	66.9	71.5	52.9	78.9	29.5	62.5	62.5	66.4	49.7	73.3	27.0
	80	71.8	71.8	72.5	71.4	79.6	49.0	67.3	67.3	67.5	67.5	74.0	46.6
	85	76.8	76.8	76.9	76.9	80.1	67.6	72.1	72.1	72.1	72.1	74.6	65.0
	90	81.8	81.8	81.9	81.9	82.0	82.0	76.9	76.9	77.0	77.0	77.1	77.1

**Notes:**

1. All capacities shown are gross and have not considered indoor fan heat. To obtain **NET** cooling capacity subtract indoor fan heat. For indoor fan heat formula, refer to appropriate airflow table notes.
2. MBh = Total Gross Capacity
3. SHC = Sensible Heat Capacity



## Gross Cooling Capacities

**Table 33. Gross cooling capacities 10 tons high efficiency - full load - three phase W/DHC120H3,4,W**

cfm	Ent DB (°F)	Ambient Temperature (°F)						Ambient Temperature (°F)						Ambient Temperature (°F)					
		85						95						105					
		Entering Wet Bulb (°F)						Entering Wet Bulb (°F)						Entering Wet Bulb (°F)					
		61		67		73		61		67		73		61		67		73	
	MBh	SHC	MBh	SHC	MBh	SHC	MBh	SHC	MBh	SHC	MBh	SHC	MBh	SHC	MBh	SHC	MBh	SHC	
3200	75	114.2	92.2	127.0	71.2	140.5	49.4	107.3	88.4	119.4	67.5	132.1	45.7	100.2	84.6	111.5	63.7	123.4	42.0
	80	114.9	109.0	127.3	88.5	140.7	66.9	108.2	105.2	119.7	84.8	132.3	63.3	101.2	101.2	111.9	81.1	123.7	59.5
	85	118.8	118.8	127.6	105.9	141.0	84.4	112.9	112.9	120.1	102.2	132.7	80.7	106.8	106.8	112.3	98.4	124.1	77.0
	90	125.4	125.4	128.4	122.7	141.2	101.7	119.3	119.3	121.1	118.9	132.9	98.1	112.9	112.9	113.6	113.6	124.4	94.4
3600	75	116.6	98.5	129.4	74.8	142.9	50.4	109.5	94.7	121.5	71.1	134.1	46.6	102.1	90.8	113.3	63.7	125.1	42.8
	80	117.9	117.5	129.8	94.4	143.2	70.1	111.1	111.1	121.9	90.6	134.5	66.3	104.5	104.5	113.7	86.7	125.5	62.6
	85	123.9	123.9	130.3	113.9	143.5	89.7	117.6	117.6	122.5	110.2	134.8	86.0	111.0	111.0	114.5	105.6	125.9	82.2
	90	130.8	130.8	131.8	131.8	143.8	109.3	124.3	124.3	124.5	124.5	135.2	105.6	117.5	117.5	117.7	117.7	126.3	101.8
4000	75	118.7	104.8	131.4	78.4	144.8	51.3	111.3	100.9	123.2	74.6	135.7	47.5	103.7	96.1	114.8	70.6	126.4	43.6
	80	121.0	121.0	131.8	100.1	145.1	73.2	114.6	114.6	123.6	96.3	136.1	69.4	107.9	107.9	115.2	92.4	126.9	65.5
	85	128.3	128.3	132.6	121.9	145.5	95.0	121.6	121.6	124.6	117.2	136.5	91.2	114.6	114.6	116.4	113.1	127.3	87.4
	90	135.5	135.5	135.7	135.7	145.9	116.8	128.6	128.6	128.8	128.8	137.1	113.0	121.3	121.3	121.5	121.5	127.9	109.2
4400	75	120.5	110.2	133.0	82.0	146.3	52.2	113.0	106.1	124.6	78.0	137.0	48.3	105.2	101.9	115.9	74.0	127.5	44.4
	80	124.6	124.6	133.5	105.9	146.8	76.3	117.8	117.8	125.1	101.9	137.5	72.4	110.7	110.7	116.5	98.0	128.0	68.5
	85	132.1	132.1	134.7	128.9	147.2	100.3	125.0	125.0	126.6	124.8	138.0	96.4	117.7	117.7	118.2	118.2	128.5	92.5
	90	139.6	139.6	139.8	139.8	147.8	124.2	132.2	132.2	132.4	132.4	138.7	120.4	124.6	124.6	124.8	124.8	129.3	115.4
4800	75	122.2	116.2	134.4	85.5	147.6	53.0	114.5	112.0	125.7	81.5	138.1	49.1	106.5	106.5	116.8	77.4	128.3	45.1
	80	127.7	127.7	135.0	111.6	148.1	79.3	120.6	120.6	126.4	107.6	138.7	75.4	113.2	113.2	117.5	102.5	128.9	71.4
	85	135.4	135.4	136.7	136.6	148.5	105.5	128.0	128.0	128.4	128.4	139.1	101.6	120.3	120.3	120.3	120.3	129.4	97.6
	90	143.1	143.1	143.3	143.3	149.4	131.7	135.4	135.4	135.6	135.6	140.1	126.6	127.4	127.4	127.6	127.6	130.6	122.5
cfm	Ent DB (°F)	Ambient Temperature (°F)						Ambient Temperature (°F)											
		115						125											
		Entering Wet Bulb (°F)						Entering Wet Bulb (°F)											
		61		67		73		61		67		73							
	MBh	SHC	MBh	SHC	MBh	SHC	MBh	SHC	MBh	SHC	MBh	SHC							
3200	75	92.7	80.7	103.3	59.8	114.3	38.2	84.7	76.0	94.5	55.7	104.5	34.2						
	80	94.2	94.2	103.7	77.2	114.7	55.7	87.4	87.4	94.9	73.1	104.9	51.7						
	85	100.2	100.2	104.2	93.9	115.0	73.2	93.1	93.1	95.5	89.7	105.3	69.1						
	90	106.2	106.2	106.4	106.4	115.4	90.6	98.8	98.8	99.0	99.0	105.7	86.5						
3600	75	94.3	86.1	104.8	63.2	115.6	38.9	86.2	81.7	95.7	59.1	105.5	34.8						
	80	97.8	97.8	105.2	82.8	116.1	58.7	90.5	90.5	96.1	78.6	106.1	54.6						
	85	104.0	104.0	106.1	101.5	116.5	78.3	96.4	96.4	97.2	97.1	106.5	74.2						
	90	110.2	110.2	110.4	110.4	117.0	97.9	102.3	102.3	102.4	102.4	107.0	93.8						
4000	75	95.8	91.9	105.9	66.6	116.7	39.7	87.4	87.4	96.5	62.4	106.3	35.5						
	80	100.7	100.7	106.5	88.3	117.3	61.6	93.0	93.0	97.1	83.2	106.9	57.4						
	85	107.2	107.2	107.9	107.9	117.7	83.4	99.1	99.1	99.3	99.3	107.3	79.2						
	90	113.6	113.6	113.8	113.8	118.4	104.2	105.2	105.2	105.3	105.3	108.2	99.8						
4400	75	97.1	97.1	106.8	69.9	117.5	40.4	88.7	88.7	97.2	65.6	106.8	36.2						
	80	103.2	103.2	107.5	92.9	118.1	64.5	95.1	95.1	98.0	88.3	107.5	60.2						
	85	109.9	109.9	109.9	109.9	118.6	88.5	101.4	101.4	101.5	101.5	108.0	84.2						
	90	116.5	116.5	116.6	116.6	119.6	111.2	107.6	107.6	107.7	107.7	109.2	106.7						
4800	75	98.4	98.4	107.5	73.2	118.1	41.1	90.4	90.4	97.6	68.9	107.2	36.8						
	80	105.3	105.3	108.4	98.1	118.8	67.4	96.9	96.9	98.7	93.4	108.0	63.1						
	85	112.1	112.1	112.3	112.3	119.4	93.5	103.3	103.3	103.4	103.4	108.6	89.3						
	90	118.9	118.9	119.1	119.1	120.7	118.2	109.6	109.6	109.8	109.8	110.2	110.2						

**Notes:**

1. All capacities shown are gross and have not considered indoor fan heat. To obtain **NET** cooling capacity subtract indoor fan heat. For indoor fan heat formula, refer to appropriate airflow table notes.
2. MBh = Total Gross Capacity
3. SHC = Sensible Heat Capacity



# Evaporator Fan Performance

**Table 34. Multispeed direct drive evaporator fan performance (standard motor) 3 to 5 tons - no electric heat WSC036/048/060H3,4,W**

Tons	Unit Model Number	cfm	External Static Pressure (in./water) and Motor Power (Bhp)														
			Speed Set 1			Speed Set 2			Speed Set 3			Speed Set 4			Speed Set 5		
			ESP	rpm	Bhp	ESP	rpm	Bhp	ESP	rpm	Bhp	ESP	rpm	Bhp	ESP	rpm	Bhp
3	WSC036H3,4,W Downflow Airflow	960	0.502	738	0.20	0.767	850	0.29	0.987	943	0.38	1.190	1029	0.47	-	-	-
		1020	0.419	717	0.19	0.683	829	0.28	0.904	923	0.37	1.107	1009	0.46	-	-	-
		1080	0.335	696	0.19	0.600	808	0.28	0.820	902	0.36	1.023	988	0.45	-	-	-
		1140	0.252	675	0.18	0.516	787	0.27	0.737	881	0.35	0.940	967	0.44	-	-	-
		1200	0.168	654	0.18	0.433	766	0.26	0.653	860	0.34	0.856	946	0.43	1.174	1080	0.58
		1260	0.084	633	0.17	0.349	746	0.25	0.570	839	0.34	0.773	925	0.42	1.090	1060	0.57
		1320	0.001	612.5	0.16	0.266	725	0.25	0.486	818	0.33	0.689	904	0.41	1.006	1039	0.56
		1440	-	-	-	0.182	704	0.24	0.403	797	0.32	0.605	883	0.40	0.923	1018	0.55
3	WSC036H3,4,WH horizontal Airflow	960	0.457	703	0.19	0.718	815	0.28	0.936	908	0.36	1.136	994	0.45	-	-	-
		1020	0.379	682	0.18	0.640	794	0.27	0.858	886	0.35	1.058	973	0.44	-	-	-
		1080	0.301	661	0.18	0.562	772	0.26	0.780	864	0.35	0.980	951	0.43	-	-	-
		1140	0.224	639	0.17	0.485	751	0.26	0.702	842	0.34	0.902	930	0.42	-	-	-
		1200	0.146	618	0.17	0.407	729	0.25	0.624	820	0.33	0.824	908	0.41	1.138	1042	0.56
		1260	0.068	596	0.16	0.329	708	0.24	0.546	798	0.32	0.746	887	0.40	1.060	1021	0.55
		1320	-	-	-	0.251	687	0.23	0.468	776	0.31	0.668	865	0.39	0.982	1000	0.54
		1440	-	-	-	0.173	665	0.23	0.390	754	0.30	0.591	844	0.38	0.904	978	0.53
4	WSC048H3,4,W Downflow Airflow	1280	0.72	918	0.38	0.96	1010	0.49	1.14	1077	0.58	-	-	-	-	-	-
		1360	0.57	885	0.37	0.82	977	0.47	1.00	1045	0.56	-	-	-	-	-	-
		1440	0.42	852	0.35	0.67	945	0.46	0.85	1012	0.54	-	-	-	-	-	-
		1520	0.27	819	0.34	0.52	912	0.44	0.70	979	0.52	1.13	1139	0.75	-	-	-
		1600	0.12	787	0.33	0.37	879	0.43	0.55	946	0.51	0.98	1106	0.72	1.19	1186	0.85
		1680	-	-	-	0.22	847	0.41	0.40	914	0.49	0.83	1073	0.70	1.05	1153	0.82
		1760	-	-	-	0.07	814	0.40	0.25	881	0.47	0.68	1040	0.68	0.90	1120	0.80
		1840	-	-	-	-	-	-	0.11	848	0.45	0.53	1008	0.66	0.75	1088	0.78
4	WSC048H3,4,WH horizontal Airflow	1280	0.68	881	0.37	0.90	972	0.47	1.06	1038	0.56	-	-	-	-	-	-
		1360	0.56	849	0.35	0.78	940	0.46	0.94	1006	0.54	-	-	-	-	-	-
		1440	0.44	817	0.34	0.66	908	0.44	0.82	974	0.52	-	-	-	-	-	-
		1520	0.33	785	0.33	0.55	876	0.43	0.71	942	0.50	1.09	1099	0.72	-	-	-
		1600	0.21	754	0.31	0.43	845	0.41	0.59	911	0.49	0.97	1067	0.70	1.16	1146	0.82
		1680	0.09	722	0.30	0.31	813	0.39	0.47	879	0.47	0.85	1036	0.68	1.04	1114	0.80
		1760	-	-	-	0.19	781	0.38	0.35	847	0.45	0.73	1004	0.66	0.92	1082	0.77
		1840	-	-	-	0.07	749	0.36	0.23	815	0.44	0.61	972	0.64	0.80	1051	0.75
5	WSC060H3,4,W Downflow Airflow	1600	0.87	830	0.46	1.00	909	0.53	1.20	996	0.64	-	-	-	-	-	-
		1700	0.73	795	0.44	0.86	873	0.51	1.05	960	0.62	-	-	-	-	-	-
		1800	0.59	759	0.42	0.72	837	0.49	0.91	924	0.59	1.12	1011	0.71	-	-	-
		1900	0.44	723	0.40	0.57	802	0.47	0.77	889	0.57	0.97	975	0.68	-	-	-
		2000	0.30	687	0.38	0.43	766	0.45	0.62	853	0.55	0.83	940	0.66	1.20	1086	0.88
		2100	0.16	651	0.36	0.29	730	0.43	0.48	817	0.52	0.69	904	0.63	1.05	1050	0.85
		2200	0.01	616	0.34	0.14	694	0.41	0.34	781	0.50	0.54	868	0.61	0.91	1014	0.82
		2300	-	-	-	0.00	658	0.39	0.19	745	0.48	0.40	832	0.58	0.77	979	0.79
5	WSC060H3,4,WH horizontal Airflow	1600	0.74	778	0.32	0.84	846	0.41	0.97	919	0.49	1.12	992	0.65	-	-	-
		1700	0.62	742	0.31	0.71	809	0.39	0.85	883	0.47	0.99	956	0.63	-	-	-
		1800	0.49	706	0.29	0.58	773	0.38	0.72	846	0.45	0.86	920	0.60	1.12	1042	0.84
		1900	0.36	669	0.28	0.45	737	0.36	0.59	810	0.43	0.74	883	0.58	0.99	1006	0.81
		2000	0.23	633	0.26	0.32	700	0.34	0.46	774	0.41	0.61	847	0.55	0.87	970	0.78
		2100	0.10	596	0.25	0.20	664	0.32	0.33	737	0.39	0.48	810	0.53	0.74	933	0.75
		2200	-	-	-	0.07	628	0.30	0.21	701	0.38	0.35	774	0.51	0.61	897	0.72
		2300	-	-	-	-	-	-	0.08	665	0.36	0.22	738	0.48	0.48	861	0.69
2400	-	-	-	-	-	-	-	-	-	0.10	701	0.46	0.35	824	0.66		

**Notes:**

- For 036 models, fan motor heat (MBh) = 2.72 x Fan Bhp + 0.16. For 048 and 060 models, fan motor heat (MBh) = 2.87 x Fan Bhp + 0.15.
- Factory supplied motors, in commercial equipment, are definite purpose motors, specifically designed and tested to operate reliably and continuously at all cataloged conditions. Using the full horsepower range of our fan motors as shown in our tabular data will not result in nuisance tripping or premature motor failure. Our product's warranty will not be affected.
- For electric heat applications minimum airflow is set to 320 cfm/ton, unless specified otherwise, values found in electric heat temp rise table.
- Data includes pressure drop due to wet coil and filters.

## Evaporator Fan Performance

**Table 35. Multispeed direct drive evaporator fan performance (oversized motor) 3 to 5 tons - no electric heat  
WSC036/048/060H3,4,W**

Tons	Unit Model Number	cfm	External Static Pressure (in./water) and Motor Power (Bhp)														
			Speed Set 1			Speed Set 2			Speed Set 3			Speed Set 4			Speed Set 5		
			ESP	rpm	Bhp	ESP	rpm	Bhp	ESP	rpm	Bhp	ESP	rpm	Bhp	ESP	rpm	Bhp
3	WSC036H3,4,W Downflow Airflow	960	1.15	963	0.44	-	-	-	-	-	-	-	-	-	-	-	-
		1020	1.06	942	0.43	-	-	-	-	-	-	-	-	-	-	-	-
		1080	0.97	921	0.42	1.51	1157	0.69	-	-	-	-	-	-	-	-	-
		1140	0.88	900	0.41	1.42	1133	0.67	-	-	-	-	-	-	-	-	-
		1200	0.79	879	0.40	1.33	1109	0.66	1.45	1155	0.73	-	-	-	-	-	-
		1260	0.70	859	0.39	1.24	1086	0.65	1.36	1131	0.71	-	-	-	-	-	-
		1320	0.61	838	0.38	1.15	1062	0.63	1.28	1107	0.70	1.49	1184	0.81	-	-	-
		1380	0.52	817	0.37	1.06	1038	0.62	1.19	1084	0.68	1.40	1160	0.79	1.51	1201	0.86
1440	0.43	796	0.36	0.97	1015	0.60	1.10	1060	0.67	1.31	1136	0.78	1.42	1177	0.84		
3	WSC036H3,4,WH horizontal Airflow	960	1.14	1111	0.50	1.50	1164	0.69	-	-	-	-	-	-	-	-	
		1020	1.06	1088	0.49	1.43	1141	0.68	-	-	-	-	-	-	-	-	
		1080	0.99	1065	0.48	1.35	1118	0.67	1.44	1131	0.71	-	-	-	-	-	
		1140	0.91	1042	0.47	1.28	1095	0.65	1.36	1108	0.70	1.50	1128	0.77	-	-	-
		1200	0.84	1019	0.46	1.20	1072	0.64	1.29	1085	0.68	1.43	1105	0.76	1.50	1117	0.80
		1260	0.76	996	0.45	1.13	1049	0.62	1.21	1062	0.67	1.35	1082	0.74	1.43	1093	0.78
		1320	0.69	973	0.44	1.05	1026	0.61	1.14	1038	0.65	1.28	1059	0.72	1.35	1070	0.76
		1380	0.61	950	0.43	0.98	1003	0.60	1.06	1015	0.64	1.20	1036	0.71	1.28	1047	0.75
1440	0.54	927	0.42	0.90	980	0.58	0.99	992	0.62	1.13	1013	0.69	1.20	1024	0.73		
4	WSC048H3,4,W Downflow Airflow	1280	1.12	1016	0.58	1.50	1159	0.78	-	-	-	-	-	-	-	-	
		1360	1.00	988	0.56	1.39	1131	0.76	-	-	-	-	-	-	-	-	
		1440	0.88	961	0.55	1.27	1104	0.74	-	-	-	-	-	-	-	-	
		1520	0.77	933	0.53	1.15	1076	0.73	-	-	-	-	-	-	-	-	
		1600	0.65	905	0.52	1.04	1048	0.71	1.50	1218	0.97	-	-	-	-	-	-
		1680	0.54	877	0.50	0.92	1020	0.69	1.38	1190	0.95	-	-	-	-	-	-
		1760	0.42	850	0.49	0.81	993	0.67	1.26	1162	0.93	-	-	-	-	-	-
		1840	0.30	822	0.47	0.69	965	0.65	1.15	1134	0.90	1.50	1266	1.13	-	-	-
1920	0.19	794	0.45	0.57	937	0.63	1.03	1107	0.88	1.39	1238	1.10	1.50	1279	1.18		
4	WSC048H3,4,WH horizontal Airflow	1280	1.04	1077	0.62	1.30	1121	0.76	-	-	-	-	-	-	-	-	
		1360	0.94	1047	0.60	1.20	1091	0.74	-	-	-	-	-	-	-	-	
		1440	0.84	1016	0.58	1.10	1061	0.72	1.41	1287	1.03	-	-	-	-	-	
		1520	0.74	986	0.56	1.00	1030	0.70	1.31	1257	1.00	-	-	-	-	-	
		1600	0.64	956	0.55	0.90	1000	0.67	1.21	1226	0.98	1.45	1340	1.20	-	-	-
		1680	0.54	925	0.53	0.80	970	0.65	1.11	1196	0.95	1.35	1310	1.17	1.43	1346	1.24
		1760	0.44	895	0.51	0.70	939	0.63	1.01	1166	0.93	1.25	1280	1.14	1.33	1315	1.21
		1840	0.34	865	0.49	0.60	909	0.61	0.91	1135	0.91	1.15	1249	1.11	1.23	1285	1.18
1920	0.24	834	0.48	0.50	879	0.59	0.81	1105	0.88	1.05	1219	1.09	1.13	1255	1.16		
5	WSC060H3,4,W Downflow Airflow	1600	1.23	905	0.52	1.50	1048	0.71	-	-	-	-	-	-	-	-	
		1700	1.08	870	0.50	1.35	1014	0.68	-	-	-	-	-	-	-	-	
		1800	0.94	836	0.48	1.21	979	0.66	-	-	-	-	-	-	-	-	
		1900	0.79	801	0.46	1.06	944	0.64	1.50	1113	0.89	-	-	-	-	-	-
		2000	0.65	766	0.44	0.92	909	0.61	1.35	1079	0.86	1.50	1210	1.08	-	-	-
		2100	0.50	732	0.42	0.77	875	0.59	1.21	1044	0.83	1.36	1176	1.05	-	-	-
		2200	0.36	697	0.40	0.63	840	0.57	1.06	1009	0.80	1.21	1141	1.02	1.50	1182	0.84
		2300	0.21	662	0.38	0.48	805	0.54	0.92	975	0.78	1.07	1106	0.99	1.36	1147	1.06
2400	0.07	628	0.36	0.34	771	0.52	0.77	940	0.75	0.92	1072	0.96	1.21	1113	1.03		
5	WSC060H3,4,WH horizontal Airflow	1600	1.03	1075	0.61	1.21	1119	0.75	1.51	1316	1.05	-	-	-	-	-	
		1700	0.91	1037	0.59	1.09	1081	0.73	1.38	1278	1.02	1.49	1350	1.20	-	-	-
		1800	0.78	999	0.57	0.96	1043	0.70	1.26	1240	0.99	1.36	1312	1.17	-	-	-
		1900	0.66	961	0.55	0.84	1005	0.68	1.13	1202	0.96	1.24	1274	1.14	1.43	1347	1.24
		2000	0.53	923	0.53	0.71	967	0.65	1.01	1164	0.93	1.11	1236	1.10	1.31	1309	1.21
		2100	0.41	885	0.51	0.59	929	0.63	0.88	1126	0.90	0.99	1198	1.07	1.18	1271	1.17
		2200	0.28	847	0.48	0.46	891	0.60	0.76	1088	0.87	0.86	1160	1.04	1.06	1233	1.14
		2300	0.16	809	0.46	0.34	853	0.58	0.63	1050	0.84	0.74	1122	1.00	0.93	1195	1.10
2400	0.03	771	0.44	0.21	816	0.55	0.51	1013	0.81	0.61	1084	0.97	0.81	1157	1.07		

**Notes:**

1. For 036 models, fan motor heat (MBh) = 2.72 x Fan Bhp + 0.16. For 048 and 060 models, fan motor heat (MBh) = 2.87 x Fan Bhp + 0.15.
2. Factory supplied motors, in commercial equipment, are definite purpose motors, specifically designed and tested to operate reliably and continuously at all cataloged conditions. Using the full horsepower range of our fan motors as shown in our tabular data will not result in nuisance tripping or premature motor failure. Our product's warranty will not be affected.
3. For electric heat applications minimum airflow is set to 320 cfm/ton, unless specified otherwise, values found in electric heat temp rise table.
4. Data includes pressure drop due to wet coil and filters.



## Evaporator Fan Performance

**Table 36. Belt drive evaporator fan performance - 7.5 tons standard efficiency - WSC092H3,H4,HW downflow airflow**

External Static Pressure (Inches of Water Gauge)																					
cfm	.10"		.20"		.30"		.40"		.50"		.60"		.70"		.80"		.90"		1.00"		
	rpm	bhp	rpm	bhp	rpm	bhp	rpm	bhp	rpm	bhp	rpm	bhp	rpm	bhp	rpm	bhp	rpm	bhp	rpm	bhp	
	1-hp Standard Motor and Field Supplied Low Static Drive <sup>(a)</sup>										1-hp Standard Motor and Drive										
2400	—	—	474	0.36	524	0.44	570	0.52	611	0.59	650	0.68	686	0.76	720	0.84	752	0.93	783	1.02	
2700	458	0.39	508	0.47	554	0.55	598	0.64	638	0.73	676	0.82	711	0.91	745	1.00	776	1.09	806	1.19	
3000	498	0.52	544	0.60	587	0.69	628	0.78	666	0.88	704	0.98	738	1.08	770	1.18	801	1.28	831	1.38	
3300	539	0.67	581	0.76	621	0.85	660	0.96	696	1.06	732	1.17	766	1.28	797	1.39	828	1.49	856	1.60	
3600	580	0.85	620	0.95	657	1.05	693	1.16	728	1.27	761	1.38	794	1.50	825	1.62	855	1.74	882	1.85	
											3-hp Oversized Motor and Drive <sup>(b)</sup>										
External Static Pressure (Inches of Water Gauge)																					
cfm	1.10"		1.20"		1.30"		1.40"		1.50"		1.60"		1.70"		1.80"		1.90"		2.00"		
	rpm	bhp	rpm	bhp	rpm	bhp	rpm	bhp	rpm	bhp	rpm	bhp	rpm	bhp	rpm	bhp	rpm	bhp	rpm	bhp	
	1-hp Standard Motor and Drive										3-hp Oversized Motor and Drive <sup>(b)</sup>										
2400	813	1.10	841	1.19	868	1.28	894	1.37	920	1.46	943	1.54	967	1.63	990	1.72	1012	1.81	1035	1.90	
2700	836	1.29	864	1.39	891	1.48	917	1.58	942	1.68	966	1.78	990	1.88	1012	1.97	1035	2.07	1056	2.17	
3000	860	1.49	887	1.60	914	1.70	940	1.81	964	1.92	988	2.03	1012	2.13	1035	2.24	1056	2.35	1079	2.46	
3300	885	1.72	911	1.83	938	1.94	963	2.06	988	2.18	1012	2.30	1035	2.42	1057	2.54	1079	2.65	1100	2.77	
3600	910	1.97	937	2.09	963	2.22	988	2.34	1012	2.46	1035	2.59	1059	2.72	1081	2.85	1104	2.98	1124	3.11	
											3-hp Oversized Motor and Drive and Field Supplied High Static Drive <sup>(c)</sup>										

**Notes:**

1. For standard evaporator fan speed (rpm), reference the standard motor and sheave/fan speed applicable table in the fan performance section.
2. Data includes pressure drop due to standard filters and wet coils. No accessories or options are included in pressure drop data.
3. To determine static pressure drop due to other options/accessories, refer to the applicable table in the fan performance section.
4. 1-hp fan motor heat (MBh) = 2.829 x fan bhp + .4024. 3-hp fan motor heat (MBh) = 2.900 x Fan bhp - .3800
5. Factory supplied motors, in commercial equipment, are definite purpose motors, specifically designed and tested to operate reliably and continuously at all cataloged conditions. Using the full horsepower range of our fan motors as shown in our tabular data will not result in nuisance tripping or premature motor failure. Our product's warranty will not be affected.

(a) BAYLSDR009A

(b) BAYHSMT400A

(c) Field Supplied AK56 x 1 in. fan sheave required.

## Evaporator Fan Performance

**Table 37. Belt drive evaporator fan performance - 7.5 tons standard efficiency - WSC092H3,H4,HW horizontal airflow**

External Static Pressure (Inches of Water Gauge)																						
cfm	.10"		.20"		.30"		.40"		.50"		.60"		.70"		.80"		.90"		1.00"			
	rpm	bhp	rpm	bhp	rpm	bhp	rpm	bhp	rpm	bhp	rpm	bhp	rpm	bhp	rpm	bhp	rpm	bhp	rpm	bhp		
	<b>1-hp Standard Motor and Field Supplied Low Static Drive<sup>(a)</sup></b>								<b>1-hp Standard Motor and Drive</b>													
2400	478	0.36	528	0.43	576	0.52	626	0.62	681	0.75	731	0.88	778	1.02	821	1.15	862	1.29	901	1.43		
2700	526	0.49	570	0.57	614	0.66	656	0.76	701	0.88	751	1.02	797	1.17	840	1.32	880	1.47	920	1.63		
3000	575	0.65	615	0.74	655	0.84	694	0.94	731	1.05	770	1.17	817	1.34	859	1.50	900	1.67	938	1.83		
3300	624	0.84	661	0.94	698	1.04	734	1.15	768	1.27	802	1.39	838	1.52	878	1.69	919	1.87	957	2.05		
3600	675	1.07	709	1.17	742	1.28	776	1.41	809	1.53	840	1.65	871	1.79	903	1.92	939	2.10	977	2.29		
	<b>3-hp Oversized Motor and Drive<sup>(b)</sup></b>																					
External Static Pressure (Inches of Water Gauge)																						
cfm	1.10"		1.20"		1.30"		1.40"		1.50"		1.60"		1.70"		1.80"		1.90"		2.00"			
	rpm	bhp	rpm	bhp	rpm	bhp	rpm	bhp	rpm	bhp	rpm	bhp	rpm	bhp	rpm	bhp	rpm	bhp	rpm	bhp		
	<b>3-hp Oversized Motor and Drive<sup>(b)</sup></b>																					
2400	938	1.57	973	1.71	1007	1.86	1038	1.99	1070	2.14	1101	2.29	1130	2.44	1159	2.59	1187	2.74	1214	2.89		
2700	956	1.78	991	1.93	1024	2.08	1057	2.25	1088	2.40	1119	2.56	1149	2.73	1177	2.89	1206	3.06	1233	3.22		
3000	975	2.00	1009	2.16	1044	2.34	1075	2.51	1108	2.69	1138	2.86	1167	3.03	1195	3.21	1222	3.38	—	—		
3300	994	2.24	1028	2.42	1063	2.61	1094	2.79	1126	2.98	1155	3.16	1185	3.35	—	—	—	—	—	—		
3600	1013	2.49	1048	2.69	1081	2.88	1114	3.09	1145	3.29	—	—	—	—	—	—	—	—	—	—		
	<b>3-hp Oversized Motor and Field Supplied High Static Drive<sup>(c)</sup></b>																					

**Notes:**

1. For standard evaporator fan speed (rpm), reference the standard motor and sheave/fan speed applicable table in the fan performance section.
2. Data includes pressure drop due to standard filters and wet coils. No accessories or options are included in pressure drop data.
3. To determine static pressure drop due to other options/accessories, refer to the applicable table in the fan performance section.
4. 1-hp fan motor heat (MBh) = 2.829 x fan bhp + 4024. 3-hp fan motor heat (MBh) = 2.900 x Fan bhp - 3800.
5. Factory supplied motors, in commercial equipment, are definite purpose motors, specifically designed and tested to operate reliably and continuously at all cataloged conditions. Using the full horsepower range of our fan motors as shown in our tabular data will not result in nuisance tripping or premature motor failure. Our product's warranty will not be affected.

(a) BAYLSDR009A

(b) BAYHSMT400A

(c) Field Supplied AK56 x 1 in. fan sheave required.



## Evaporator Fan Performance

**Table 38. Direct drive evaporator fan performance - 7.5 tons standard efficiency Title 24 single zone VAV - WSC092H3,H4,HW downflow airflow**

External Static Pressure (Inches of Water Gauge)																					
cfm	.10"		.20"		.30"		.40"		.50"		.60"		.70"		.80"		.90"		1.00"		
	rpm	bhp	rpm	bhp	rpm	bhp	rpm	bhp	rpm	bhp	rpm	bhp	rpm	bhp	rpm	bhp	rpm	bhp	rpm	bhp	
2400	713	0.21	763	0.26	807	0.32	851	0.39	892	0.45	924	0.50	957	0.56	991	0.62	1024	0.68	1054	0.74	
2700	792	0.28	834	0.34	880	0.41	914	0.47	955	0.54	992	0.62	1023	0.68	1051	0.74	1081	0.81	1112	0.88	
3000	871	0.36	908	0.43	949	0.51	987	0.58	1018	0.65	1054	0.73	1090	0.81	1120	0.89	1145	0.96	1171	1.02	
3300	950	0.47	985	0.54	1020	0.62	1058	0.71	1090	0.79	1118	0.86	1151	0.95	1184	1.04	1214	1.13	1240	1.21	
3600	1030	0.60	1062	0.67	1094	0.76	1128	0.84	1162	0.94	1191	1.03	1216	1.10	1245	1.20	1276	1.30	1305	1.40	
External Static Pressure (Inches of Water Gauge)																					
cfm	1.10"		1.20"		1.30"		1.40"		1.50"		1.60"		1.70"		1.80"		1.90"		2.00"		
	rpm	bhp	rpm	bhp	rpm	bhp	rpm	bhp	rpm	bhp	rpm	bhp	rpm	bhp	rpm	bhp	rpm	bhp	rpm	bhp	
2400	1084	0.79	1113	0.85	1141	0.90	1168	0.95	1194	1.00	1218	1.05	1243	1.10	1267	1.14	1290	1.19	1314	1.23	
2700	1140	0.94	1169	1.01	1195	1.07	1222	1.13	1248	1.20	1273	1.25	1296	1.31	1321	1.37	1343	1.43	1366	1.48	
3000	1198	1.10	1225	1.18	1252	1.25	1278	1.32	1303	1.40	1328	1.47	1351	1.54	1375	1.61	1398	1.67	1419	1.74	
3300	1262	1.28	1285	1.35	1309	1.43	1335	1.52	1360	1.60	1384	1.69	1407	1.77	1429	1.84	1452	1.92	1475	2.00	
3600	1331	1.49	1355	1.58	1375	1.65	1396	1.74	1418	1.82	1441	1.91	1464	2.01	1487	2.10	1509	2.19	1530	2.27	

**Notes:**

1. For direct drive fan speed (rpm), reference the applicable table in the fan performance section.
2. Data includes pressure drop due to standard filters and wet coils. No accessories or options are included in pressure drop data.
3. To determine static pressure drop due to other options/accessories, refer to the applicable table in the fan performance section.
4. Direct drive fan motor heat (MBh) = 2.7912 x fan bhp + 0.1388.
5. Factory supplied motors, in commercial equipment, are definite purpose motors, specifically designed and tested to operate reliably and continuously at all cataloged conditions. Using the full horsepower range of our fan motors as shown in our tabular data will not result in nuisance tripping or premature motor failure. Our product's warranty will not be affected.

## Evaporator Fan Performance

**Table 39. Direct drive evaporator fan performance - 7.5 tons standard efficiency Title 24 single zone VAV - WSC092H3,H4,HW horizontal airflow**

External Static Pressure (Inches of Water Gauge)																					
cfm	.10"		.20"		.30"		.40"		.50"		.60"		.70"		.80"		.90"		1.00"		
	rpm	bhp	rpm	bhp	rpm	bhp	rpm	bhp	rpm	bhp	rpm	bhp	rpm	bhp	rpm	bhp	rpm	bhp	rpm	bhp	
2400	720	0.21	769	0.27	817	0.33	856	0.39	894	0.44	929	0.50	964	0.56	997	0.62	1028	0.69	1060	0.75	
2700	800	0.29	841	0.34	888	0.42	927	0.48	962	0.55	995	0.61	1027	0.67	1058	0.74	1088	0.81	1118	0.88	
3000	880	0.38	917	0.44	956	0.51	999	0.59	1032	0.67	1063	0.74	1094	0.81	1123	0.88	1151	0.95	1178	1.02	
3300	961	0.49	994	0.55	1028	0.63	1067	0.72	1104	0.80	1133	0.88	1162	0.96	1190	1.04	1218	1.12	1243	1.19	
3600	1042	0.62	1073	0.69	1104	0.77	1136	0.85	1173	0.95	1205	1.05	1233	1.13	1259	1.22	1285	1.30	1310	1.39	
External Static Pressure (Inches of Water Gauge)																					
cfm	1.10"		1.20"		1.30"		1.40"		1.50"		1.60"		1.70"		1.80"		1.90"		2.00"		
	rpm	bhp	rpm	bhp	rpm	bhp	rpm	bhp	rpm	bhp	rpm	bhp	rpm	bhp	rpm	bhp	rpm	bhp	rpm	bhp	
2400	1090	0.82	1119	0.89	1147	0.96	1174	1.03	1200	1.10	1226	1.18	1251	1.25	1276	1.33	1299	1.41	1323	1.49	
2700	1147	0.95	1175	1.02	1202	1.10	1228	1.17	1254	1.25	1279	1.33	1304	1.41	1327	1.49	1350	1.57	1374	1.66	
3000	1206	1.10	1233	1.18	1259	1.26	1285	1.34	1309	1.42	1333	1.50	1359	1.59	1381	1.67	1405	1.76	1427	1.85	
3300	1269	1.27	1294	1.35	1320	1.44	1344	1.52	1367	1.61	1391	1.70	1414	1.78	1438	1.88	1460	1.97	1482	2.06	
3600	1335	1.48	1359	1.56	1382	1.64	1405	1.73	1428	1.82	1451	1.91	1473	2.01	1496	2.10	1518	2.20	1538	2.29	

**Notes:**

1. For direct drive evaporator fan speed (rpm), refer to the applicable table in the fan performance section.
2. Data includes pressure drop due to standard filters and wet coils.
3. To determine static pressure drop due to other options/accessories, refer to the applicable table in the fan performance section.
4. Direct drive fan motor heat (MBh) = 2.7912 x fan bhp + 0.1388.
5. Factory supplied motors, in commercial equipment, are definite purpose motors, specifically designed and tested to operate reliably and continuously at all cataloged conditions. Using the full horsepower range of our fan motors as shown in our tabular data will not result in nuisance tripping or premature motor failure. Our product's warranty will not be affected.



## Evaporator Fan Performance

**Table 40. Belt drive evaporator fan performance - 8.5 tons standard efficiency - WSC102H3,H4,HW downflow airflow**

External Static Pressure (Inches of Water)																					
cfm	.10"		.20"		.30"		.40"		.50"		.60"		.70"		.80"		.90"		1.00"		
	rpm	bhp	rpm	bhp	rpm	bhp	rpm	bhp	rpm	bhp	rpm	bhp	rpm	bhp	rpm	bhp	rpm	bhp	rpm	bhp	
<b>2-hp Standard Motor and Field Supplied Low Static Drive<sup>(a)</sup></b>																					
2720	-	-	519	0.43	563	0.50	603	0.57	644	0.65	681	0.73	716	0.81	749	0.88	780	0.96	809	1.03	
3060	513	0.48	558	0.56	604	0.65	640	0.73	676	0.81	713	0.90	747	0.99	779	1.07	810	1.16	840	1.25	
3400	558	0.63	600	0.72	643	0.82	681	0.92	714	1.00	745	1.09	779	1.19	811	1.29	841	1.39	870	1.49	
3740	605	0.82	645	0.92	683	1.02	722	1.13	754	1.24	783	1.33	811	1.42	842	1.53	872	1.64	901	1.75	
4080	654	1.04	691	1.16	724	1.26	760	1.38	795	1.50	824	1.61	851	1.71	876	1.81	904	1.92	932	2.04	
<b>2-hp Standard Motor and Drive</b>																					
External Static Pressure (Inches of Water)																					
cfm	1.10"		1.20"		1.30"		1.40"		1.50"		1.60"		1.70"		1.80"		1.90"		2.00"		
	rpm	bhp	rpm	bhp	rpm	bhp	rpm	bhp	rpm	bhp	rpm	bhp	rpm	bhp	rpm	bhp	rpm	bhp	rpm	bhp	
<b>2-hp Standard Motor and Drive</b>																					
2720	838	1.11	865	1.18	891	1.26	916	1.33	940	1.40	963	1.47	986	1.54	1008	1.61	1030	1.69	1051	1.76	
3060	867	1.33	893	1.41	919	1.50	945	1.59	968	1.66	992	1.75	1014	1.83	1037	1.91	1058	2.00	1079	2.08	
3400	897	1.58	923	1.68	949	1.77	974	1.87	997	1.96	1020	2.05	1044	2.15	1065	2.24	1087	2.33	1107	2.42	
3740	928	1.86	954	1.96	980	2.07	1003	2.18	1027	2.28	1050	2.39	1072	2.49	1094	2.59	1115	2.70	1136	2.80	
4080	959	2.16	985	2.29	1010	2.40	1034	2.52	1058	2.64	1079	2.75	1102	2.87	1124	2.98	1145	3.10	1165	3.21	
<b>3-hp Oversized Motor and Drive<sup>(b)</sup></b>																					

**Notes:**

- For standard evaporator fan speed (rpm), reference the standard motor and sheave/fan speed applicable table in the fan performance section.
- Data includes pressure drop due to standard filters and wet coils.
- To determine static pressure drop due to other options/accessories, refer to the applicable table in the fan performance section.
- 1-hp fan motor heat (MBh) = 2.829 x fan bhp + .4024. 2-hp fan motor heat (MBh) = 2.000 x fan bhp +.5000. 3-hp fan motor heat (MBh) = 2.900 x fan bhp + .4750
- Factory supplied motors, in commercial equipment, are definite purpose motors, specifically designed and tested to operate reliably and continuously at all cataloged conditions. Using the full horsepower range of our fan motors as shown in our tabular data will not result in nuisance tripping or premature motor failure. Our product's warranty will not be affected.
- For electric heat applications, minimum airflow is set to 320 cfm/ton, unless specified otherwise, values found in electric heat temperature rise table.

(a) BAYLSDR009A  
 (b) BAYHSMT097A



## Evaporator Fan Performance

**Table 41. Belt drive evaporator fan performance - 8.5 tons standard efficiency - WSC102H3,H4,HW horizontal airflow**

External Static Pressure (Inches of Water)																					
cfm	.10"		.20"		.30"		.40"		.50"		.60"		.70"		.80"		.90"		1.00"		
	rpm	bhp	rpm	bhp	rpm	bhp	rpm	bhp	rpm	bhp	rpm	bhp	rpm	bhp	rpm	bhp	rpm	bhp	rpm	bhp	
<b>2-hp Standard Motor and Field Supplied Low Static Drive Accessory Kit<sup>(a)</sup></b>																					
2720	523	0.43	571	0.50	619	0.59	676	0.69	721	0.80	759	0.90	795	1.00	830	1.10	862	1.20	893	1.30	
3060	578	0.59	625	0.68	659	0.75	706	0.86	757	0.98	800	1.10	834	1.21	866	1.33	899	1.44	929	1.55	
3400	633	0.79	673	0.88	710	0.97	744	1.07	788	1.19	833	1.32	874	1.46	907	1.58	937	1.71	967	1.84	
3740	690	1.03	723	1.12	764	1.24	791	1.33	825	1.44	864	1.57	907	1.72	945	1.87	979	2.02	1007	2.15	
4080	747	1.31	777	1.41	812	1.53	844	1.65	869	1.75	901	1.87	938	2.02	976	2.18	1013	2.35	1048	2.51	
<b>2-hp Standard Motor and Drive</b>																					
External Static Pressure (Inches of Water)																					
cfm	1.10"		1.20"		1.30"		1.40"		1.50"		1.60"		1.70"		1.80"		1.90"		2.00"		
	rpm	bhp	rpm	bhp	rpm	bhp	rpm	bhp	rpm	bhp	rpm	bhp	rpm	bhp	rpm	bhp	rpm	bhp	rpm	bhp	
<b>2-hp Standard Motor and Drive</b>																					
2720	924	1.40	952	1.50	980	1.60	1006	1.70	1032	1.81	1057	1.91	1081	2.01	1105	2.11	1127	2.21	1150	2.31	
3060	959	1.66	987	1.77	1014	1.89	1041	2.01	1066	2.11	1091	2.23	1115	2.34	1138	2.46	1161	2.57	1184	2.69	
3400	995	1.96	1024	2.09	1051	2.21	1077	2.34	1102	2.46	1126	2.59	1150	2.72	1173	2.84	1196	2.97	1217	3.09	
3740	1034	2.29	1060	2.43	1087	2.57	1113	2.71	1138	2.84	1162	2.98	1185	3.12	1208	3.25	1230	3.39	-	-	
4080	1076	2.66	1101	2.81	1126	2.96	1150	3.11	1175	3.26	1198	3.41	-	-	-	-	-	-	-	-	
<b>3-hp Oversized Motor and Drive<sup>(b)</sup></b>																					

**Notes:**

1. For standard evaporator fan speed (rpm), reference the standard motor and sheave/fan speed applicable table in the fan performance section.
2. Data includes pressure drop due to standard filters and wet coils.
3. To determine static pressure drop due to other options/accessories, refer to the applicable table in the fan performance section.
4. 1-hp fan motor heat (MBh) = 2.829 x fan bhp + .4024. 2-hp fan motor heat (MBh) = 2.000 x fan bhp +.5000. 3-hp fan motor heat (MBh) = 2.900 x fan bhp + .4750
5. Factory supplied motors, in commercial equipment, are definite purpose motors, specifically designed and tested to operate reliably and continuously at all cataloged conditions. Using the full horsepower range of our fan motors as shown in our tabular data will not result in nuisance tripping or premature motor failure. Our product's warranty will not be affected.
6. For electric heat applications, minimum airflow is set to 320 cfm/ton, unless specified otherwise, values found in electric heat temperature rise table.

(a) BAYLSDR009A  
(b) BAYHSMT097A



## Evaporator Fan Performance

**Table 42. Direct drive evaporator fan performance - 8.5 tons standard efficiency Title 24 single zone VAV - WSC102H3,H4,HW downflow airflow**

External Static Pressure (Inches of Water)																					
cfm	.10"		.20"		.30"		.40"		.50"		.60"		.70"		.80"		.90"		1.00"		
	rpm	bhp	rpm	bhp	rpm	bhp	rpm	bhp	rpm	bhp	rpm	bhp	rpm	bhp	rpm	bhp	rpm	bhp	rpm	bhp	
2720	812	0.31	857	0.37	899	0.44	935	0.50	976	0.58	1011	0.65	1040	0.72	1068	0.78	1099	0.85	1129	0.92	
3060	904	0.42	942	0.49	983	0.57	1017	0.64	1049	0.71	1086	0.80	1119	0.89	1149	0.96	1174	1.03	1197	1.10	
3400	997	0.55	1030	0.63	1066	0.71	1103	0.81	1132	0.89	1160	0.96	1193	1.06	1225	1.16	1254	1.25	1279	1.33	
3740	1090	0.72	1120	0.80	1152	0.89	1185	0.99	1218	1.09	1244	1.17	1269	1.25	1298	1.36	1329	1.47	1356	1.57	
4080	1183	0.92	1211	1.01	1240	1.10	1270	1.20	1301	1.31	1330	1.42	1354	1.51	1377	1.60	1402	1.70	1430	1.82	
External Static Pressure (Inches of Water)																					
cfm	1.10"		1.20"		1.30"		1.40"		1.50"		1.60"		1.70"		1.80"		1.90"		2.00"		
	rpm	bhp	rpm	bhp	rpm	bhp	rpm	bhp	rpm	bhp	rpm	bhp	rpm	bhp	rpm	bhp	rpm	bhp	rpm	bhp	
2720	1158	0.99	1186	1.05	1213	1.11	1238	1.18	1264	1.24	1289	1.30	1313	1.36	1336	1.42	1359	1.47	1382	1.53	
3060	1226	1.18	1253	1.26	1279	1.33	1305	1.41	1329	1.48	1353	1.55	1377	1.63	1400	1.70	1422	1.76	1444	1.83	
3400	1301	1.40	1323	1.48	1347	1.56	1372	1.65	1396	1.74	1421	1.83	1444	1.91	1465	1.99	1487	2.07	1509	2.15	
3740	1382	1.67	1406	1.76	1426	1.84	1445	1.92	1465	2.01	1489	2.11	1510	2.20	1533	2.30	1554	2.39	1576	2.49	
4080	1457	1.94	1482	2.05	1506	2.16	1527	2.26	1546	2.35	1565	2.44	1583	2.53	1602	2.63	1623	2.73	1643	2.84	

**Notes:**

1. For direct drive evaporator fan speed (rpm), refer to the applicable table in the fan performance section.
2. Data includes pressure drop due to standard filters and wet coils.
3. To determine static pressure drop due to other options/accessories, refer to the applicable table in the fan performance section.
4. Direct drive fan motor heat (MBh) = 2.7912 x fan bhp + 0.1388
5. Factory supplied motors, in commercial equipment, are definite purpose motors, specifically designed and tested to operate reliably and continuously at all cataloged conditions. Using the full horsepower range of our fan motors as shown in our tabular data will not result in nuisance tripping or premature motor failure. Our product's warranty will not be affected.

## Evaporator Fan Performance

**Table 43. Direct drive evaporator fan performance - 8.5 tons standard efficiency Title 24 single zone VAV - WSC102H3,H4,HW horizontal airflow**

External Static Pressure (Inches of Water)																					
cfm	.10"		.20"		.30"		.40"		.50"		.60"		.70"		.80"		.90"		1.00"		
	rpm	bhp	rpm	bhp	rpm	bhp	rpm	bhp	rpm	bhp	rpm	bhp	rpm	bhp	rpm	bhp	rpm	bhp	rpm	bhp	
2720	821	0.31	864	0.38	911	0.45	947	0.52	982	0.58	1015	0.65	1046	0.71	1077	0.78	1107	0.85	1137	0.93	
3060	914	0.43	951	0.50	993	0.58	1032	0.66	1063	0.73	1095	0.81	1125	0.88	1153	0.95	1181	1.03	1208	1.10	
3400	1008	0.57	1041	0.64	1076	0.73	1115	0.82	1148	0.91	1177	0.99	1204	1.07	1232	1.15	1259	1.24	1284	1.32	
3740	1103	0.75	1132	0.82	1163	0.91	1197	1.01	1232	1.11	1262	1.21	1288	1.30	1313	1.38	1339	1.47	1364	1.57	
4080	1198	0.95	1225	1.04	1253	1.13	1281	1.22	1314	1.33	1345	1.45	1372	1.55	1397	1.65	1420	1.75	1444	1.84	

External Static Pressure (Inches of Water)																					
cfm	1.10"		1.20"		1.30"		1.40"		1.50"		1.60"		1.70"		1.80"		1.90"		2.00"		
	rpm	bhp	rpm	bhp	rpm	bhp	rpm	bhp	rpm	bhp	rpm	bhp	rpm	bhp	rpm	bhp	rpm	bhp	rpm	bhp	
2720	1165	1.00	1193	1.07	1220	1.15	1245	1.22	1271	1.30	1296	1.38	1322	1.47	1344	1.55	1368	1.63	1391	1.72	
3060	1235	1.18	1261	1.26	1288	1.34	1313	1.43	1337	1.51	1361	1.59	1385	1.68	1408	1.77	1431	1.86	1453	1.95	
3400	1310	1.40	1334	1.48	1359	1.57	1382	1.66	1406	1.75	1430	1.84	1453	1.93	1474	2.02	1496	2.12	1518	2.21	
3740	1388	1.66	1411	1.75	1433	1.83	1456	1.93	1477	2.02	1500	2.11	1522	2.21	1544	2.31	1565	2.41	1586	2.51	
4080	1467	1.95	1489	2.04	1512	2.14	1533	2.24	1554	2.34	1575	2.43	1594	2.53	1616	2.64	1636	2.74	-	-	

**Notes:**

1. For direct drive evaporator fan speed (rpm), refer to the applicable table in the fan performance section.
2. Data includes pressure drop due to standard filters and wet coils.
3. To determine static pressure drop due to other options/accessories, refer to the applicable table in the fan performance section.
4. Direct drive fan motor heat (MBh) = 2.7912 x fan bhp + 0.1388
5. Factory supplied motors, in commercial equipment, are definite purpose motors, specifically designed and tested to operate reliably and continuously at all cataloged conditions. Using the full horsepower range of our fan motors as shown in our tabular data will not result in nuisance tripping or premature motor failure. Our product's warranty will not be affected.



## Evaporator Fan Performance

**Table 44. Direct drive evaporator fan performance - 10 tons standard efficiency - WSC120H3,H4,HW downflow airflow**

External Static Pressure (Inches of Water)																					
cfm	.10"		.20"		.30"		.40"		.50"		.60"		.70"		.80"		.90"		1.00"		
	rpm	bhp	rpm	bhp	rpm	bhp	rpm	bhp	rpm	bhp	rpm	bhp	rpm	bhp	rpm	bhp	rpm	bhp	rpm	bhp	
3200	942	0.47	978	0.54	1017	0.63	1053	0.71	1082	0.78	1116	0.87	1150	0.96	1181	1.04	1207	1.12	1231	1.19	
3600	1051	0.65	1083	0.73	1116	0.81	1152	0.91	1183	1.00	1209	1.08	1237	1.17	1268	1.27	1298	1.38	1325	1.47	
4000	1161	0.87	1190	0.96	1219	1.05	1249	1.15	1282	1.26	1310	1.36	1334	1.45	1357	1.54	1385	1.65	1412	1.76	
4400	1272	1.13	1298	1.23	1324	1.33	1351	1.44	1379	1.54	1409	1.67	1435	1.79	1457	1.88	1478	1.98	1501	2.08	
4800	1383	1.45	1407	1.56	1431	1.66	1455	1.78	1480	1.89	1506	2.01	1532	2.14	1558	2.28	1579	2.39	1599	2.49	
External Static Pressure (Inches of Water)																					
cfm	1.10"		1.20"		1.30"		1.40"		1.50"		1.60"		1.70"		1.80"		1.90"		2.00"		
	rpm	bhp	rpm	bhp	rpm	bhp	rpm	bhp	rpm	bhp	rpm	bhp	rpm	bhp	rpm	bhp	rpm	bhp	rpm	bhp	
3200	1254	1.26	1282	1.35	1307	1.43	1332	1.51	1357	1.59	1381	1.66	1404	1.74	1427	1.82	1449	1.89	1471	1.96	
3600	1350	1.56	1372	1.64	1392	1.72	1412	1.80	1437	1.90	1460	1.99	1483	2.08	1504	2.17	1526	2.26	1548	2.35	
4000	1440	1.88	1464	1.98	1488	2.08	1508	2.18	1527	2.26	1545	2.35	1564	2.44	1586	2.55	1606	2.65	1627	2.75	
4400	1526	2.20	1552	2.33	1576	2.46	1600	2.58	1621	2.69	1642	2.80	1660	2.90	-	-	-	-	-	-	
4800	1618	2.60	1639	2.71	1663	2.85	-	-	-	-	-	-	-	-	-	-	-	-	-	-	

**Notes:**

1. For direct drive evaporator fan speed (rpm), refer to the applicable table in the fan performance section.
2. Data includes pressure drop due to standard filters and wet coils.
3. To determine static pressure drop due to other options/accessories, refer to the applicable table in the fan performance section.
4. Direct drive fan motor heat (MBh) = 2.8623 x fan bhp + 0.1504
5. Factory supplied motors, in commercial equipment, are definite purpose motors, specifically designed and tested to operate reliably and continuously at all cataloged conditions. Using the full horsepower range of our fan motors as shown in our tabular data will not result in nuisance tripping or premature motor failure. Our product's warranty will not be affected.

## Evaporator Fan Performance

**Table 45. Direct drive evaporator fan performance - 10 tons standard efficiency - WSC120H3,H4,HW horizontal airflow**

External Static Pressure (Inches of Water)																					
		.10"		.20"		.30"		.40"		.50"		.60"		.70"		.80"		.90"		1.00"	
cfm		rpm	bhp	rpm	bhp	rpm	bhp	rpm	bhp	rpm	bhp	rpm	bhp	rpm	bhp	rpm	bhp	rpm	bhp	rpm	bhp
3200		953	0.48	988	0.55	1027	0.64	1067	0.73	1098	0.80	1128	0.88	1157	0.96	1186	1.03	1213	1.11	1239	1.19
3600		1064	0.67	1095	0.75	1126	0.83	1163	0.93	1198	1.03	1226	1.11	1253	1.20	1280	1.29	1306	1.37	1331	1.46
4000		1175	0.90	1203	0.98	1231	1.07	1260	1.17	1294	1.28	1327	1.39	1353	1.49	1377	1.58	1401	1.68	1425	1.78
4400		1288	1.18	1313	1.27	1338	1.36	1364	1.46	1392	1.57	1422	1.70	1452	1.82	1477	1.93	1500	2.04	1522	2.14
4800		1400	1.51	1423	1.61	1446	1.71	1470	1.82	1494	1.93	1519	2.05	1547	2.18	1575	2.32	1600	2.45	1622	2.56
External Static Pressure (Inches of Water)																					
		1.10"		1.20"		1.30"		1.40"		1.50"		1.60"		1.70"		1.80"		1.90"		2.00"	
cfm		rpm	bhp	rpm	bhp	rpm	bhp	rpm	bhp	rpm	bhp	rpm	bhp	rpm	bhp	rpm	bhp	rpm	bhp	rpm	bhp
3200		1265	1.27	1291	1.35	1316	1.43	1342	1.52	1365	1.60	1389	1.69	1412	1.78	1435	1.87	1458	1.96	1479	2.05
3600		1355	1.54	1378	1.63	1401	1.72	1425	1.81	1447	1.90	1471	2.00	1492	2.09	1515	2.19	1536	2.28	1557	2.38
4000		1448	1.87	1471	1.97	1494	2.07	1515	2.16	1536	2.26	1557	2.36	1578	2.46	1598	2.56	1619	2.66	1640	2.77
4400		1543	2.24	1565	2.35	1586	2.46	1607	2.56	1628	2.67	1647	2.77	1667	2.88	1686	2.98	-	-	-	-
4800		1642	2.68	1662	2.79	1682	2.91	1701	3.02	-	-	-	-	-	-	-	-	-	-	-	-

**Notes:**

1. For direct drive evaporator fan speed (rpm), refer to the applicable table in the fan performance section.
2. Data includes pressure drop due to standard filters and wet coils.
3. To determine static pressure drop due to other options/accessories, refer to the applicable table in the fan performance section.
4. Direct drive fan motor heat (MBh) = 2.8623 x fan bhp + 0.1504
5. Factory supplied motors, in commercial equipment, are definite purpose motors, specifically designed and tested to operate reliably and continuously at all cataloged conditions. Using the full horsepower range of our fan motors as shown in our tabular data will not result in nuisance tripping or premature motor failure. Our product's warranty will not be affected.



## Evaporator Fan Performance

**Table 46. Direct drive evaporator fan performance - 3 tons high efficiency - W/DHC036H3,H4,HW downflow airflow**

External Static Pressure (Inches of Water)																					
cfm	.10"		.20"		.30"		.40"		.50"		.60"		.70"		.80"		.90"		1.00"		
	rpm	bhp	rpm	bhp	rpm	bhp	rpm	bhp	rpm	bhp	rpm	bhp	rpm	bhp	rpm	bhp	rpm	bhp	rpm	bhp	
<b>Standard Static Motor</b>																					
960	539	0.11	585	0.15	632	0.18	679	0.22	725	0.26	772	0.29	819	0.33	865	0.37	912	0.41	927	0.44	
1080	566	0.16	613	0.20	659	0.24	706	0.27	753	0.31	800	0.35	846	0.38	893	0.42	940	0.46	948	0.49	
1200	594	0.21	640	0.25	687	0.29	734	0.32	780	0.36	827	0.40	874	0.43	920	0.47	930	0.51	968	0.54	
1320	621	0.26	668	0.30	714	0.34	761	0.37	808	0.41	854	0.45	901	0.49	948	0.52	950	0.56	988	0.60	
1440	648	0.31	695	0.35	742	0.39	789	0.43	835	0.46	882	0.50	929	0.54	932	0.57	971	0.61	1009	0.65	
<b>High Static Motor Option<sup>(a)</sup></b>																					
External Static Pressure (Inches of Water)																					
cfm	1.10"		1.20"		1.30"		1.40"		1.50"												
	rpm	bhp	rpm	bhp	rpm	bhp	rpm	bhp	rpm	bhp											
<b>High Static Motor Option<sup>(a)</sup></b>																					
960	965	0.48	1004	0.52	1042	0.55	1080	0.59	1118	0.63											
1080	986	0.53	1024	0.57	1062	0.60	1100	0.64	1139	0.67											
1200	1006	0.58	1044	0.62	1083	0.66	1121	0.70	1159	0.74											
1320	1027	0.63	1065	0.67	1103	0.70	1141	0.73	1179	0.76											
1440	1047	0.68	1085	0.70	1123	0.74	1162	0.77	1200	0.80											

**Notes:**

1. For constant cfm direct drive fan, refer to the voltage vs. cfm table in the fan performance section.
2. Data includes pressure drop due to standard filters and wet coils.
3. To determine static pressure drop due to other options/accessories, refer to the applicable table in the fan performance section.
4. Direct drive fan motor heat (MBh) = 2.9245 x fan bhp + 0.055
5. Factory supplied motors, in commercial equipment, are definite purpose motors, specifically designed and tested to operate reliably and continuously at all cataloged conditions. Using the full horsepower range of our fan motors as shown in our tabular data will not result in nuisance tripping or premature motor failure. Our product's warranty will not be affected.

(a) High Static Motor Option not available on DHC models.

## Evaporator Fan Performance

**Table 47. Direct drive evaporator fan performance - 3 tons high efficiency - W/DHC036H3,H4,HW horizontal airflow**

External Static Pressure (Inches of Water)																					
cfm	.10"		.20"		.30"		.40"		.50"		.60"		.70"		.80"		.90"		1.00"		
	rpm	bhp	rpm	bhp	rpm	bhp	rpm	bhp	rpm	bhp	rpm	bhp	rpm	bhp	rpm	bhp	rpm	bhp	rpm	bhp	
<b>Standard Static Motor</b>																					
960	-	-	515	0.15	565	0.18	614	0.22	663	0.26	713	0.29	762	0.33	812	0.37	861	0.41	921	0.44	
1080	-	-	541	0.20	590	0.24	640	0.27	689	0.31	738	0.35	788	0.38	837	0.42	887	0.46	940	0.49	
1200	517	0.21	566	0.25	616	0.29	665	0.32	715	0.36	764	0.40	813	0.43	863	0.47	921	0.51	959	0.54	
1320	543	0.26	592	0.30	641	0.34	691	0.37	740	0.41	790	0.45	839	0.49	888	0.52	940	0.56	978	0.60	
1440	568	0.31	618	0.35	667	0.39	716	0.43	766	0.46	815	0.50	865	0.54	922	0.57	960	0.61	997	0.65	
<b>High Static Motor Option<sup>(a)</sup></b>																					
External Static Pressure (Inches of Water)																					
cfm	1.10"		1.20"		1.30"		1.40"		1.50"												
	rpm	bhp	rpm	bhp	rpm	bhp	rpm	bhp	rpm	bhp											
<b>High Static Motor Option<sup>(a)</sup></b>																					
960	958	0.48	995	0.52	1033	0.55	1070	0.59	1108	0.63											
1080	977	0.53	1015	0.57	1052	0.60	1089	0.64	1127	0.67											
1200	996	0.58	1034	0.62	1071	0.66	1108	0.70	1146	0.74											
1320	1015	0.63	1053	0.67	1090	0.70	1127	0.73	1165	0.76											
1440	1034	0.68	1072	0.70	1109	0.74	1147	0.77	1184	0.80											

**Notes:**

1. For constant cfm direct drive fan, refer to the voltage vs. cfm table in the fan performance section.
2. Data includes pressure drop due to standard filters and wet coils.
3. To determine static pressure drop due to other options/accessories, refer to the applicable table in the fan performance section.
4. Direct drive fan motor heat (MBh) = 2.9245 x fan bhp + 0.055
5. Factory supplied motors, in commercial equipment, are definite purpose motors, specifically designed and tested to operate reliably and continuously at all cataloged conditions. Using the full horsepower range of our fan motors as shown in our tabular data will not result in nuisance tripping or premature motor failure. Our product's warranty will not be affected.

(a) High Static Motor Option not available on DHC models.



## Evaporator Fan Performance

**Table 48. Direct drive evaporator fan performance - 4 tons high efficiency - W/DHC048H3,H4,HW downflow airflow**

External Static Pressure (Inches of Water)																					
cfm	.10"		.20"		.30"		.40"		.50"		.60"		.70"		.80"		.90"		1.00"		
	rpm	bhp	rpm	bhp	rpm	bhp	rpm	bhp	rpm	bhp	rpm	bhp	rpm	bhp	rpm	bhp	rpm	bhp	rpm	bhp	
<b>Standard Static Motor</b>																					
1280	541	0.07	585	0.12	628	0.18	672	0.23	715	0.28	759	0.33	802	0.39	846	0.44	889	0.49	905	0.55	
1440	564	0.15	608	0.2	651	0.25	695	0.3	738	0.36	782	0.41	825	0.46	869	0.51	912	0.57	925	0.62	
1600	587	0.22	631	0.27	674	0.33	718	0.38	761	0.43	805	0.48	848	0.54	892	0.59	901	0.64	945	0.70	
1760	610	0.3	654	0.35	697	0.4	741	0.45	784	0.51	828	0.56	871	0.61	915	0.66	921	0.72	965	0.77	
1920	634	0.37	677	0.42	721	0.48	764	0.53	808	0.58	851	0.63	895	0.69	898	0.74	941	0.79	985	0.85	
<b>High Static Motor Option<sup>(a)</sup></b>																					
External Static Pressure (Inches of Water)																					
cfm	1.10"		1.20"		1.30"		1.40"		1.50"												
	rpm	bhp	rpm	bhp	rpm	bhp	rpm	bhp	rpm	bhp											
<b>High Static Motor Option<sup>(a)</sup></b>																					
1280	949	0.60	992	0.65	1036	0.70	1079	0.76	1123	0.81											
1440	969	0.67	1012	0.73	1056	0.78	1099	0.83	1143	0.88											
1600	989	0.75	1032	0.80	1076	0.85	1119	0.91	1163	0.96											
1760	1009	0.82	1052	0.88	1096	0.93	1139	0.98	1183	1.03											
1920	1029	0.90	1072	0.95	1116	1.00	1159	1.06	1203	1.11											

**Notes:**

1. For constant cfm direct drive fan, refer to the voltage vs. cfm table in the fan performance section.
2. Data includes pressure drop due to standard filters and wet coils.
3. To determine static pressure drop due to other options/accessories, refer to the applicable table in the fan performance section.
4. Direct drive fan motor heat (MBh) = 2.9245 x fan bhp + 0.055
5. Factory supplied motors, in commercial equipment, are definite purpose motors, specifically designed and tested to operate reliably and continuously at all cataloged conditions. Using the full horsepower range of our fan motors as shown in our tabular data will not result in nuisance tripping or premature motor failure. Our product's warranty will not be affected.

(a) High Static Motor Option not available on DHC models.



## Evaporator Fan Performance

**Table 49. Direct drive evaporator fan performance - 4 tons high efficiency - W/DHC048H3,H4,HW horizontal airflow**

External Static Pressure (Inches of Water)																					
cfm	.10"		.20"		.30"		.40"		.50"		.60"		.70"		.80"		.90"		1.00"		
	rpm	bhp	rpm	bhp	rpm	bhp	rpm	bhp	rpm	bhp	rpm	bhp	rpm	bhp	rpm	bhp	rpm	bhp	rpm	bhp	
<b>Standard Static Motor</b>																					
1280	591	0.07	632	0.12	674	0.18	715	0.23	756	0.28	798	0.33	839	0.39	880	0.44	922	0.49	968	0.55	
1440	621	0.15	663	0.2	704	0.25	745	0.3	787	0.36	828	0.41	869	0.46	911	0.51	952	0.57	1005	0.62	
1600	652	0.22	693	0.27	734	0.33	776	0.38	817	0.43	858	0.48	900	0.54	941	0.59	1008	0.64	1041	0.70	
1760	682	0.3	723	0.35	765	0.4	806	0.45	847	0.51	889	0.56	930	0.61	971	0.66	1045	0.72	1078	0.77	
1920	712	0.37	754	0.42	795	0.48	836	0.53	878	0.58	919	0.63	960	0.69	1048	0.74	1082	0.79	1115	0.85	
<b>High Static Motor Option<sup>(a)</sup></b>																					
External Static Pressure (Inches of Water)																					
cfm	1.10"		1.20"		1.30"		1.40"		1.50"												
	rpm	bhp	rpm	bhp	rpm	bhp	rpm	bhp	rpm	bhp											
<b>High Static Motor Option<sup>(a)</sup></b>																					
1280	1001	0.60	1034	0.65	1067	0.70	1101	0.76	1134	0.81											
1440	1038	0.67	1071	0.73	1104	0.78	1137	0.83	1170	0.88											
1600	1075	0.75	1108	0.80	1141	0.85	1174	0.91	1207	0.96											
1760	1111	0.82	1144	0.88	1177	0.93	1210	0.98	1244	1.03											
1920	1148	0.90	1181	0.95	1214	1.00	1247	1.06	1280	1.11											

**Notes:**

1. For constant cfm direct drive fan, refer to the voltage vs. cfm table in the fan performance section.
2. Data includes pressure drop due to standard filters and wet coils.
3. To determine static pressure drop due to other options/accessories, refer to the applicable table in the fan performance section.
4. Direct drive fan motor heat (MBh) = 2.9245 x fan bhp + 0.055
5. Factory supplied motors, in commercial equipment, are definite purpose motors, specifically designed and tested to operate reliably and continuously at all cataloged conditions. Using the full horsepower range of our fan motors as shown in our tabular data will not result in nuisance tripping or premature motor failure. Our product's warranty will not be affected.

(a) High Static Motor Option not available on DHC models.



## Evaporator Fan Performance

**Table 50. Direct drive evaporator fan performance - 5 tons high efficiency - W/DHC060H3,H4,HW downflow airflow**

External Static Pressure (Inches of Water)																					
cfm	.10"		.20"		.30"		.40"		.50"		.60"		.70"		.80"		.90"		1.00"		
	rpm	bhp	rpm	bhp	rpm	bhp	rpm	bhp	rpm	bhp	rpm	bhp	rpm	bhp	rpm	bhp	rpm	bhp	rpm	bhp	
<b>Standard Static Motor</b>																					
1600	618	0.13	656	0.18	693	0.23	731	0.28	769	0.33	806	0.38	844	0.43	881	0.48	919	0.53	932	0.58	
1800	651	0.24	689	0.29	727	0.34	764	0.39	802	0.44	839	0.49	877	0.54	915	0.59	957	0.64	961	0.69	
2000	685	0.35	722	0.4	760	0.45	798	0.5	835	0.55	873	0.6	910	0.65	948	0.7	952	0.75	991	0.80	
2200	718	0.46	756	0.51	793	0.56	831	0.61	869	0.66	906	0.71	944	0.76	981	0.81	981	0.86	1021	0.91	
2400	752	0.57	789	0.62	827	0.67	864	0.72	902	0.77	940	0.82	977	0.87	971	0.92	1011	0.97	1050	1.02	
<b>High Static Motor Option<sup>(a)</sup></b>																					
External Static Pressure (Inches of Water)																					
cfm	1.10"		1.20"		1.30"		1.40"		1.50"												
	rpm	bhp	rpm	bhp	rpm	bhp	rpm	bhp	rpm	bhp											
<b>High Static Motor Option<sup>(a)</sup></b>																					
1600	971	0.63	1011	0.68	1050	0.73	1089	0.79	1129	0.84											
1800	1001	0.74	1040	0.79	1080	0.84	1119	0.89	1158	0.92											
2000	1030	0.85	1070	0.90	1109	0.95	1149	0.99	1188	1.02											
2200	1060	0.96	1099	1.01	1139	1.04	1178	1.06	1218	1.09											
2400	1090	1.05	1129	1.07	1168	1.10	1208	1.13	1247	1.16											

**Notes:**

1. For constant cfm direct drive fan, refer to the voltage vs. cfm table in the fan performance section.
2. Data includes pressure drop due to standard filters and wet coils.
3. To determine static pressure drop due to other options/accessories, refer to the applicable table in the fan performance section.
4. Direct drive fan motor heat (MBh) = 2.9245 x fan bhp +0.055
5. Factory supplied motors, in commercial equipment, are definite purpose motors, specifically designed and tested to operate reliably and continuously at all cataloged conditions. Using the full horsepower range of our fan motors as shown in our tabular data will not result in nuisance tripping or premature motor failure. Our product's warranty will not be affected.

(a) High Static Motor Option not available on DHC models.

## Evaporator Fan Performance

**Table 51. Direct drive evaporator fan performance - 5 tons high efficiency - W/DHC060H3,H4,HW horizontal airflow**

External Static Pressure (Inches of Water)																					
cfm	.10"		.20"		.30"		.40"		.50"		.60"		.70"		.80"		.90"		1.00"		
	rpm	bhp	rpm	bhp	rpm	bhp	rpm	bhp	rpm	bhp	rpm	bhp	rpm	bhp	rpm	bhp	rpm	bhp	rpm	bhp	
<b>Standard Static Motor</b>																					
1600	680	0.14	717	0.19	753	0.25	790	0.31	827	0.36	864	0.42	901	0.47	937	0.48	974	0.53	1047	0.58	
1800	716	0.27	753	0.32	789	0.38	826	0.44	863	0.49	900	0.55	937	0.61	973	0.59	1010	0.64	1084	0.69	
2000	752	0.4	789	0.46	825	0.51	862	0.57	899	0.63	936	0.68	973	0.74	1009	0.7	1084	0.75	1120	0.80	
2200	788	0.53	825	0.59	861	0.65	898	0.7	935	0.76	972	0.82	1009	0.87	1045	0.81	1121	0.86	1156	0.91	
2400	824	0.67	861	0.72	897	0.78	934	0.84	971	0.89	1008	0.95	1045	1.01	1121	0.92	1157	0.97	1193	1.02	
<b>High Static Motor Option<sup>(a)</sup></b>																					
External Static Pressure (Inches of Water)																					
cfm	1.10"		1.20"		1.30"		1.40"		1.50"												
	rpm	bhp	rpm	bhp	rpm	bhp	rpm	bhp	rpm	bhp											
<b>High Static Motor Option<sup>(a)</sup></b>																					
1600	1083	0.63	1119	0.68	1155	0.73	1191	0.79	1227	0.84											
1800	1120	0.74	1155	0.79	1191	0.84	1227	0.89	1263	0.92											
2000	1156	0.85	1192	0.90	1228	0.95	1264	0.99	1300	1.02											
2200	1192	0.96	1228	1.01	1264	1.04	1300	1.06	1336	1.09											
2400	1229	1.05	1265	1.07	1301	1.10	1336	1.13	1372	1.16											

**Notes:**

1. For constant cfm direct drive fan, refer to the voltage vs. cfm table in the fan performance section.
2. Data includes pressure drop due to standard filters and wet coils.
3. To determine static pressure drop due to other options/accessories, refer to the applicable table in the fan performance section.
4. Direct drive fan motor heat (MBh) = 2.9245 x fan bhp + 0.055
5. Factory supplied motors, in commercial equipment, are definite purpose motors, specifically designed and tested to operate reliably and continuously at all cataloged conditions. Using the full horsepower range of our fan motors as shown in our tabular data will not result in nuisance tripping or premature motor failure. Our product's warranty will not be affected.

(a) High Static Motor Option not available on DHC models.



## Evaporator Fan Performance

**Table 52. Direct drive evaporator fan performance - 6 tons high efficiency - WHC074H3,4,W downflow airflow**

External Static Pressure (Inches of Water)																					
cfm	.10"		.20"		.30"		.40"		.50"		.60"		.70"		.80"		.90"		1.00"		
	rpm	bhp	rpm	bhp	rpm	bhp	rpm	bhp	rpm	bhp	rpm	bhp	rpm	bhp	rpm	bhp	rpm	bhp	rpm	bhp	
1920	598	0.10	649	0.14	695	0.18	736	0.23	773	0.27	808	0.32	841	0.37	872	0.41	901	0.46	930	0.52	
2160	660	0.14	707	0.18	750	0.23	789	0.27	825	0.32	859	0.37	891	0.42	921	0.47	950	0.53	977	0.58	
2400	722	0.18	767	0.23	807	0.27	844	0.32	879	0.38	912	0.43	943	0.48	972	0.54	1000	0.60	1027	0.66	
2640	785	0.23	827	0.28	865	0.33	900	0.38	934	0.44	965	0.50	995	0.56	1024	0.62	1051	0.68	1077	0.74	
2880	848	0.28	888	0.34	924	0.40	958	0.45	990	0.51	1020	0.58	1049	0.64	1077	0.70	1103	0.77	1129	0.83	
External Static Pressure (Inches of Water)																					
cfm	1.10"		1.20"		1.30"		1.40"		1.50"		1.60"		1.70"		1.80"		1.90"		2.00"		
	rpm	bhp	rpm	bhp	rpm	bhp	rpm	bhp	rpm	bhp	rpm	bhp	rpm	bhp	rpm	bhp	rpm	bhp	rpm	bhp	
1920	957	0.57	983	0.63	1009	0.68	1032	0.74	1056	0.8	1079	0.85	1101	0.92	1122	0.98	1143	1.04	1164	1.1	
2160	1004	0.64	1029	0.7	1055	0.76	1078	0.82	1101	0.88	1124	0.94	1146	1	1167	1.07	1188	1.13	1209	1.2	
2400	1053	0.72	1077	0.78	1102	0.84	1125	0.9	1148	0.97	1171	1.04	1192	1.1	1213	1.17	1234	1.24	1254	1.31	
2640	1103	0.8	1127	0.87	1151	0.93	1174	1	1196	1.07	1218	1.14	1239	1.21	1260	1.28	1280	1.35	1300	1.42	
2880	1154	0.9	1177	0.97	1201	1.04	1223	1.11	1245	1.18	1267	1.25	1287	1.32	1308	1.4	1328	1.47	1348	1.55	

**Notes:**

1. For direct drive evaporator fan speed (rpm), refer to the applicable table in the fan performance section.
2. Data includes pressure drop due to standard filters and wet coils.
3. To determine static pressure drop due to other options/accessories, refer to the applicable table in the fan performance section.
4. Direct drive fan motor heat (MBh) = 2.7912 x fan bhp + 0.1388
5. Factory supplied motors, in commercial equipment, are definite purpose motors, specifically designed and tested to operate reliably and continuously at all cataloged conditions. Using the full horsepower range of our fan motors as shown in our tabular data will not result in nuisance tripping or premature motor failure. Our product's warranty will not be affected.

## Evaporator Fan Performance

**Table 53. Direct drive evaporator fan performance - 6 tons high efficiency - WHC074H3,4,W horizontal airflow**

External Static Pressure (Inches of Water)																					
cfm	.10"		.20"		.30"		.40"		.50"		.60"		.70"		.80"		.90"		1.00"		
	rpm	bhp	rpm	bhp	rpm	bhp	rpm	bhp	rpm	bhp	rpm	bhp	rpm	bhp	rpm	bhp	rpm	bhp	rpm	bhp	
1920	583	0.07	638	0.10	686	0.12	729	0.15	768	0.18	805	0.21	839	0.24	871	0.27	902	0.30	931	0.33	
2160	642	0.09	693	0.12	739	0.15	780	0.18	818	0.21	853	0.24	887	0.28	918	0.31	948	0.34	977	0.38	
2400	702	0.11	750	0.15	793	0.19	832	0.22	869	0.25	903	0.29	935	0.32	966	0.35	996	0.39	1023	0.43	
2640	762	0.14	807	0.19	848	0.23	886	0.26	921	0.30	954	0.33	986	0.37	1015	0.41	1043	0.45	1071	0.48	
2880	823	0.17	865	0.22	904	0.27	940	0.31	974	0.35	1006	0.39	1037	0.43	1066	0.47	1094	0.51	1121	0.55	
External Static Pressure (Inches of Water)																					
cfm	1.10"		1.20"		1.30"		1.40"		1.50"		1.60"		1.70"		1.80"		1.90"		2.00"		
	rpm	bhp	rpm	bhp	rpm	bhp	rpm	bhp	rpm	bhp	rpm	bhp	rpm	bhp	rpm	bhp	rpm	bhp	rpm	bhp	
1920	960	0.36	986	0.40	1013	0.43	1038	0.46	1062	0.50	1085	0.54	1108	0.57	1131	0.61	1153	0.65	1175	0.69	
2160	1004	0.41	1031	0.45	1057	0.48	1082	0.52	1106	0.56	1129	0.59	1152	0.63	1173	0.67	1194	0.71	1216	0.75	
2400	1051	0.47	1077	0.50	1102	0.54	1126	0.58	1150	0.62	1173	0.66	1195	0.70	1217	0.74	1238	0.78	1259	0.83	
2640	1098	0.52	1123	0.56	1148	0.61	1172	0.65	1195	0.69	1218	0.73	1240	0.77	1261	0.82	1282	0.86	1303	0.91	
2880	1147	0.59	1171	0.63	1195	0.68	1219	0.72	1242	0.76	1264	0.81	1286	0.85	1307	0.9	1328	0.95	1348	0.99	

**Notes:**

1. For direct drive evaporator fan speed (rpm), refer to the applicable table in the fan performance section.
2. Data includes pressure drop due to standard filters and wet coils.
3. To determine static pressure drop due to other options/accessories, refer to the applicable table in the fan performance section.
4. Direct drive fan motor heat (MBh) = 2.7912 x fan bhp + 0.1388
5. Factory supplied motors, in commercial equipment, are definite purpose motors, specifically designed and tested to operate reliably and continuously at all cataloged conditions. Using the full horsepower range of our fan motors as shown in our tabular data will not result in nuisance tripping or premature motor failure. Our product's warranty will not be affected.



## Evaporator Fan Performance

**Table 54. Direct drive evaporator fan performance - 6 tons high efficiency dual fuel low/medium heat - DHC074H3,4,W downflow airflow**

External Static Pressure (Inches of Water)																					
cfm	.10"		.20"		.30"		.40"		.50"		.60"		.70"		.80"		.90"		1.00"		
	rpm	bhp	rpm	bhp	rpm	bhp	rpm	bhp	rpm	bhp	rpm	bhp	rpm	bhp	rpm	bhp	rpm	bhp	rpm	bhp	
1920	625	0.15	678	0.20	727	0.25	770	0.30	810	0.35	847	0.41	882	0.46	915	0.52	947	0.58	976	0.64	
2160	691	0.20	737	0.25	784	0.31	826	0.37	864	0.42	900	0.48	934	0.54	966	0.61	997	0.67	1026	0.73	
2400	757	0.26	799	0.32	842	0.38	882	0.44	919	0.51	955	0.57	987	0.64	1018	0.70	1049	0.77	1077	0.84	
2640	824	0.34	864	0.40	901	0.46	941	0.53	977	0.60	1010	0.67	1042	0.74	1073	0.81	1101	0.88	1129	0.96	
2880	892	0.42	929	0.49	963	0.55	999	0.63	1034	0.71	1067	0.78	1098	0.86	1127	0.94	1155	1.01	1183	1.09	
External Static Pressure (Inches of Water)																					
cfm	1.10"		1.20"		1.30"		1.40"		1.50"		1.60"		1.70"		1.80"		1.90"		2.00"		
	rpm	bhp	rpm	bhp	rpm	bhp	rpm	bhp	rpm	bhp	rpm	bhp	rpm	bhp	rpm	bhp	rpm	bhp	rpm	bhp	
1920	1005	0.70	1033	0.76	1060	0.83	1086	0.89	1111	0.96	1135	1.03	1158	1.09	1181	1.17	1203	1.23	1225	1.31	
2160	1054	0.80	1082	0.87	1107	0.93	1133	1.00	1158	1.08	1182	1.15	1205	1.22	1228	1.29	1250	1.37	1272	1.45	
2400	1105	0.91	1131	0.98	1157	1.05	1182	1.13	1206	1.20	1229	1.28	1252	1.35	1275	1.43	1297	1.51	1318	1.59	
2640	1156	1.03	1183	1.11	1208	1.19	1232	1.27	1255	1.34	1279	1.42	1302	1.51	1323	1.59	1344	1.67	1365	1.75	
2880	1209	1.17	1234	1.25	1259	1.34	1283	1.42	1306	1.50	1330	1.59	1351	1.67	1373	1.76	1394	1.84	1414	1.93	

**Notes:**

1. For direct drive evaporator fan speed (rpm), refer to the applicable table in the fan performance section.
2. Data includes pressure drop due to standard filters and wet coils.
3. To determine static pressure drop due to other options/accessories, refer to the applicable table in the fan performance section.
4. Direct drive fan motor heat (MBh) = 2.7912 x fan bhp + 0.1388
5. Factory supplied motors, in commercial equipment, are definite purpose motors, specifically designed and tested to operate reliably and continuously at all cataloged conditions. Using the full horsepower range of our fan motors as shown in our tabular data will not result in nuisance tripping or premature motor failure. Our product's warranty will not be affected.

## Evaporator Fan Performance

**Table 55. Direct drive evaporator fan performance - 6 tons high efficiency dual fuel low/medium heat - DHC074H3,4,W horizontal airflow**

External Static Pressure (Inches of Water)																					
cfm	.10"		.20"		.30"		.40"		.50"		.60"		.70"		.80"		.90"		1.00"		
	rpm	bhp	rpm	bhp	rpm	bhp	rpm	bhp	rpm	bhp	rpm	bhp	rpm	bhp	rpm	bhp	rpm	bhp	rpm	bhp	
1920	583	0.07	638	0.10	686	0.12	729	0.15	768	0.18	805	0.21	839	0.24	871	0.27	902	0.30	931	0.33	
2160	642	0.09	693	0.12	739	0.15	780	0.18	818	0.21	853	0.24	887	0.28	918	0.31	948	0.34	977	0.38	
2400	702	0.11	750	0.15	793	0.19	832	0.22	869	0.25	903	0.29	935	0.32	966	0.35	996	0.39	1023	0.43	
2640	762	0.14	807	0.19	848	0.23	886	0.26	921	0.30	954	0.33	986	0.37	1015	0.41	1043	0.45	1071	0.48	
2880	823	0.17	865	0.22	904	0.27	940	0.31	974	0.35	1006	0.39	1037	0.43	1066	0.47	1094	0.51	1121	0.55	
External Static Pressure (Inches of Water)																					
cfm	1.10"		1.20"		1.30"		1.40"		1.50"		1.60"		1.70"		1.80"		1.90"		2.00"		
	rpm	bhp	rpm	bhp	rpm	bhp	rpm	bhp	rpm	bhp	rpm	bhp	rpm	bhp	rpm	bhp	rpm	bhp	rpm	bhp	
1920	960	0.36	986	0.40	1013	0.43	1038	0.46	1062	0.50	1085	0.54	1108	0.57	1131	0.61	1153	0.65	1175	0.69	
2160	1004	0.41	1031	0.45	1057	0.48	1082	0.52	1106	0.56	1129	0.59	1152	0.63	1173	0.67	1194	0.71	1216	0.75	
2400	1051	0.47	1077	0.50	1102	0.54	1126	0.58	1150	0.62	1173	0.66	1195	0.70	1217	0.74	1238	0.78	1259	0.83	
2640	1098	0.52	1123	0.56	1148	0.61	1172	0.65	1195	0.69	1218	0.73	1240	0.77	1261	0.82	1282	0.86	1303	0.91	
2880	1147	0.59	1171	0.63	1195	0.68	1219	0.72	1242	0.76	1264	0.81	1286	0.85	1307	0.90	1328	0.95	1348	0.99	

**Notes:**

1. For direct drive evaporator fan speed (rpm), refer to the applicable table in the fan performance section.
2. Data includes pressure drop due to standard filters and wet coils.
3. To determine static pressure drop due to other options/accessories, refer to the applicable table in the fan performance section.
4. Direct drive fan motor heat (MBh) = 2.7912 x fan bhp + 0.1388
5. Factory supplied motors, in commercial equipment, are definite purpose motors, specifically designed and tested to operate reliably and continuously at all cataloged conditions. Using the full horsepower range of our fan motors as shown in our tabular data will not result in nuisance tripping or premature motor failure. Our product's warranty will not be affected.



## Evaporator Fan Performance

**Table 56. Direct drive evaporator fan performance - 6 tons high efficiency dual fuel high heat - DHC074H3,4,W downflow airflow**

External Static Pressure (Inches of Water)																					
cfm	.10"		.20"		.30"		.40"		.50"		.60"		.70"		.80"		.90"		1.00"		
	rpm	bhp	rpm	bhp	rpm	bhp	rpm	bhp	rpm	bhp	rpm	bhp	rpm	bhp	rpm	bhp	rpm	bhp	rpm	bhp	
1920	611	0.15	665	0.20	709	0.25	759	0.31	800	0.36	839	0.41	877	0.47	915	0.53	949	0.59	982	0.66	
2160	674	0.20	724	0.26	765	0.31	807	0.37	851	0.43	888	0.49	922	0.55	959	0.62	992	0.68	1025	0.75	
2400	739	0.26	783	0.32	826	0.39	860	0.44	899	0.51	938	0.58	974	0.65	1006	0.71	1037	0.78	1068	0.85	
2640	804	0.34	844	0.40	886	0.47	920	0.54	951	0.60	987	0.67	1024	0.75	1058	0.83	1087	0.90	1114	0.97	
2880	870	0.42	907	0.49	944	0.57	982	0.64	1011	0.71	1039	0.78	1073	0.86	1106	0.95	1138	1.04	1167	1.12	
External Static Pressure (Inches of Water)																					
cfm	1.10"		1.20"		1.30"		1.40"		1.50"		1.60"		1.70"		1.80"		1.90"		2.00"		
	rpm	bhp	rpm	bhp	rpm	bhp	rpm	bhp	rpm	bhp	rpm	bhp	rpm	bhp	rpm	bhp	rpm	bhp	rpm	bhp	
1920	1014	0.72	1044	0.78	1073	0.85	1101	0.91	1128	0.98	1155	1.05	1180	1.11	1205	1.18	1230	1.26	1253	1.33	
2160	1056	0.82	1085	0.89	1114	0.96	1142	1.03	1170	1.10	1195	1.17	1221	1.25	1246	1.32	1270	1.40	1293	1.47	
2400	1098	0.93	1128	1.00	1156	1.08	1184	1.15	1210	1.23	1237	1.31	1262	1.39	1287	1.47	1310	1.55	1334	1.63	
2640	1144	1.05	1173	1.13	1201	1.21	1228	1.29	1253	1.38	1279	1.46	1304	1.54	1329	1.63	1352	1.72	1375	1.80	
2880	1193	1.19	1219	1.27	1245	1.35	1272	1.44	1298	1.53	1322	1.62	1348	1.71	1372	1.80	1395	1.89	1418	1.99	

**Notes:**

1. For direct drive evaporator fan speed (rpm), refer to the applicable table in the fan performance section.
2. Data includes pressure drop due to standard filters and wet coils.
3. To determine static pressure drop due to other options/accessories, refer to the applicable table in the fan performance section.
4. Direct drive fan motor heat (MBh) = 2.7912 x fan bhp + 0.1388
5. Factory supplied motors, in commercial equipment, are definite purpose motors, specifically designed and tested to operate reliably and continuously at all cataloged conditions. Using the full horsepower range of our fan motors as shown in our tabular data will not result in nuisance tripping or premature motor failure. Our product's warranty will not be affected.



## Evaporator Fan Performance

**Table 57. Direct drive evaporator fan performance - 6 tons high efficiency dual fuel high heat - DHC074H3,4,W horizontal airflow**

External Static Pressure (Inches of Water)																					
cfm	.10"		.20"		.30"		.40"		.50"		.60"		.70"		.80"		.90"		1.00"		
	rpm	bhp	rpm	bhp	rpm	bhp	rpm	bhp	rpm	bhp	rpm	bhp	rpm	bhp	rpm	bhp	rpm	bhp	rpm	bhp	
1920	601	0.14	657	0.19	707	0.24	754	0.29	797	0.35	839	0.41	879	0.47	916	0.53	951	0.59	984	0.66	
2160	663	0.18	712	0.24	762	0.30	804	0.35	846	0.41	884	0.47	922	0.54	958	0.61	993	0.68	1026	0.74	
2400	725	0.24	770	0.29	816	0.36	858	0.43	896	0.49	933	0.55	969	0.62	1003	0.69	1036	0.76	1069	0.84	
2640	789	0.30	831	0.36	871	0.43	913	0.51	950	0.58	983	0.64	1018	0.72	1052	0.80	1082	0.87	1112	0.95	
2880	852	0.38	892	0.45	929	0.52	966	0.59	1004	0.68	1038	0.76	1069	0.83	1101	0.91	1131	0.99	1161	1.07	
External Static Pressure (Inches of Water)																					
cfm	1.10"		1.20"		1.30"		1.40"		1.50"		1.60"		1.70"		1.80"		1.90"		2.00"		
	rpm	bhp	rpm	bhp	rpm	bhp	rpm	bhp	rpm	bhp	rpm	bhp	rpm	bhp	rpm	bhp	rpm	bhp	rpm	bhp	
1920	1016	0.72	1047	0.79	1078	0.87	1106	0.94	1134	1.01	1162	1.09	1187	1.16	1213	1.24	1237	1.31	1261	1.39	
2160	1058	0.82	1089	0.89	1117	0.96	1146	1.04	1173	1.12	1201	1.20	1227	1.28	1252	1.36	1276	1.44	1300	1.52	
2400	1100	0.92	1130	0.99	1159	1.07	1187	1.15	1214	1.24	1241	1.32	1266	1.40	1292	1.49	1316	1.58	1339	1.66	
2640	1143	1.03	1173	1.11	1201	1.19	1230	1.28	1256	1.37	1282	1.45	1308	1.54	1332	1.63	1356	1.72	1379	1.81	
2880	1189	1.15	1216	1.24	1245	1.33	1271	1.41	1298	1.51	1324	1.60	1349	1.69	1374	1.79	1398	1.88	1421	1.98	

**Notes:**

1. For direct drive evaporator fan speed (rpm), refer to the applicable table in the fan performance section.
2. Data includes pressure drop due to standard filters and wet coils.
3. To determine static pressure drop due to other options/accessories, refer to the applicable table in the fan performance section.
4. Direct drive fan motor heat (MBh) = 2.7912 x fan bhp + 0.1388
5. Factory supplied motors, in commercial equipment, are definite purpose motors, specifically designed and tested to operate reliably and continuously at all cataloged conditions. Using the full horsepower range of our fan motors as shown in our tabular data will not result in nuisance tripping or premature motor failure. Our product's warranty will not be affected.



## Evaporator Fan Performance

**Table 58. Direct drive evaporator fan performance - 7.5 tons high efficiency - WHC092H3,4,W downflow airflow**

External Static Pressure (Inches of Water)																					
cfm	.10"		.20"		.30"		.40"		.50"		.60"		.70"		.80"		.90"		1.00"		
	rpm	bhp	rpm	bhp	rpm	bhp	rpm	bhp	rpm	bhp	rpm	bhp	rpm	bhp	rpm	bhp	rpm	bhp	rpm	bhp	
2400	706	0.17	752	0.21	792	0.26	830	0.31	865	0.36	897	0.41	928	0.47	958	0.52	987	0.58	1013	0.64	
2700	784	0.22	825	0.27	863	0.33	898	0.38	932	0.44	963	0.49	993	0.55	1021	0.61	1049	0.67	1075	0.74	
3000	862	0.29	900	0.35	936	0.41	969	0.46	1001	0.53	1031	0.59	1059	0.65	1086	0.72	1113	0.78	1138	0.85	
3300	941	0.37	975	0.44	1009	0.50	1040	0.56	1070	0.63	1099	0.70	1127	0.76	1153	0.83	1178	0.90	1203	0.97	
3600	1021	0.47	1052	0.54	1083	0.61	1113	0.68	1142	0.75	1169	0.82	1195	0.89	1221	0.97	1245	1.04	1268	1.12	
External Static Pressure (Inches of Water)																					
cfm	1.10"		1.20"		1.30"		1.40"		1.50"		1.60"		1.70"		1.80"		1.90"		2.00"		
	rpm	bhp	rpm	bhp	rpm	bhp	rpm	bhp	rpm	bhp	rpm	bhp	rpm	bhp	rpm	bhp	rpm	bhp	rpm	bhp	
2400	1039	0.70	1065	0.76	1089	0.82	1112	0.88	1135	0.95	1157	1.01	1178	1.08	1199	1.15	1221	1.22	1240	1.28	
2700	1100	0.80	1125	0.87	1148	0.93	1171	1.00	1193	1.07	1215	1.14	1236	1.21	1257	1.28	1276	1.35	1296	1.42	
3000	1162	0.91	1187	0.99	1209	1.05	1232	1.13	1254	1.20	1275	1.27	1295	1.35	1315	1.42	1335	1.50	1354	1.58	
3300	1227	1.05	1249	1.12	1272	1.20	1293	1.27	1314	1.35	1335	1.43	1356	1.50	1376	1.59	1396	1.67	1415	1.75	
3600	1292	1.20	1315	1.27	1335	1.35	1357	1.43	1377	1.51	1398	1.60	1418	1.68	1437	1.76	1457	1.85	1475	1.93	

**Notes:**

1. For direct drive evaporator fan speed (rpm), refer to the applicable table in the fan performance section.
2. Data includes pressure drop due to standard filters and wet coils.
3. To determine static pressure drop due to other options/accessories, refer to the applicable table in the fan performance section.
4. Direct drive fan motor heat (MBh) = 2.7912 x fan bhp + 0.1388
5. Factory supplied motors, in commercial equipment, are definite purpose motors, specifically designed and tested to operate reliably and continuously at all cataloged conditions. Using the full horsepower range of our fan motors as shown in our tabular data will not result in nuisance tripping or premature motor failure. Our product's warranty will not be affected.

## Evaporator Fan Performance

**Table 59. Direct drive evaporator fan performance - 7.5 tons high efficiency - WHC092H3,4,W horizontal airflow**

External Static Pressure (Inches of Water)																					
cfm	.10"		.20"		.30"		.40"		.50"		.60"		.70"		.80"		.90"		1.00"		
	rpm	bhp	rpm	bhp	rpm	bhp	rpm	bhp	rpm	bhp	rpm	bhp	rpm	bhp	rpm	bhp	rpm	bhp	rpm	bhp	
2400	697	0.20	741	0.25	785	0.31	823	0.37	862	0.43	898	0.49	932	0.55	964	0.61	994	0.68	1024	0.74	
2700	772	0.27	813	0.33	853	0.39	890	0.45	924	0.52	959	0.59	992	0.66	1023	0.72	1052	0.79	1081	0.86	
3000	849	0.35	886	0.42	921	0.49	958	0.55	991	0.63	1022	0.70	1053	0.78	1083	0.85	1112	0.93	1140	1.00	
3300	926	0.45	961	0.53	993	0.60	1026	0.67	1060	0.74	1089	0.83	1117	0.91	1145	0.99	1173	1.08	1200	1.16	
3600	1004	0.58	1037	0.65	1067	0.73	1096	0.81	1126	0.89	1157	0.97	1184	1.06	1210	1.15	1235	1.24	1262	1.34	
External Static Pressure (Inches of Water)																					
cfm	1.10"		1.20"		1.30"		1.40"		1.50"		1.60"		1.70"		1.80"		1.90"		2.00"		
	rpm	bhp	rpm	bhp	rpm	bhp	rpm	bhp	rpm	bhp	rpm	bhp	rpm	bhp	rpm	bhp	rpm	bhp	rpm	bhp	
2400	1051	0.81	1079	0.88	1105	0.95	1130	1.02	1154	1.09	1179	1.16	1202	1.24	1225	1.31	1246	1.39	1268	1.46	
2700	1109	0.94	1135	1.01	1161	1.08	1185	1.16	1210	1.24	1233	1.31	1256	1.39	1278	1.47	1299	1.55	1321	1.64	
3000	1167	1.08	1193	1.16	1217	1.24	1241	1.32	1266	1.40	1287	1.48	1310	1.56	1333	1.65	1354	1.74	1375	1.83	
3300	1226	1.24	1251	1.33	1275	1.41	1299	1.49	1322	1.58	1345	1.67	1367	1.76	1388	1.85	1410	1.94	1430	2.03	
3600	1286	1.42	1312	1.51	1335	1.60	1359	1.70	1381	1.79	1403	1.88	1425	1.98	1446	2.07	1467	2.17	1487	2.26	

**Notes:**

1. For direct drive evaporator fan speed (rpm), refer to the applicable table in the fan performance section.
2. Data includes pressure drop due to standard filters and wet coils.
3. To determine static pressure drop due to other options/accessories, refer to the applicable table in the fan performance section.
4. Direct drive fan motor heat (MBh) = 2.7912 x fan bhp + 0.1388
5. Factory supplied motors, in commercial equipment, are definite purpose motors, specifically designed and tested to operate reliably and continuously at all cataloged conditions. Using the full horsepower range of our fan motors as shown in our tabular data will not result in nuisance tripping or premature motor failure. Our product's warranty will not be affected.



## Evaporator Fan Performance

**Table 60. Direct drive evaporator fan performance - 7.5 tons high efficiency dual fuel low/medium heat - DHC092H3,4,W downflow airflow**

External Static Pressure (Inches of Water)																					
cfm	.10"		.20"		.30"		.40"		.50"		.60"		.70"		.80"		.90"		1.00"		
	rpm	bhp	rpm	bhp	rpm	bhp	rpm	bhp	rpm	bhp	rpm	bhp	rpm	bhp	rpm	bhp	rpm	bhp	rpm	bhp	
2400	742	0.24	786	0.30	826	0.36	869	0.42	906	0.48	942	0.55	975	0.61	1006	0.68	1036	0.74	1065	0.81	
2700	823	0.33	864	0.39	900	0.45	938	0.52	975	0.59	1009	0.66	1041	0.73	1071	0.81	1100	0.88	1129	0.95	
3000	905	0.43	944	0.51	978	0.57	1009	0.64	1045	0.72	1078	0.80	1109	0.88	1138	0.96	1166	1.04	1194	1.12	
3300	988	0.55	1025	0.64	1057	0.72	1086	0.79	1115	0.87	1147	0.96	1178	1.05	1206	1.13	1234	1.22	1260	1.30	
3600	1071	0.70	1105	0.80	1137	0.89	1165	0.97	1192	1.05	1218	1.13	1248	1.23	1276	1.33	1303	1.42	1328	1.51	
External Static Pressure (Inches of Water)																					
cfm	1.10"		1.20"		1.30"		1.40"		1.50"		1.60"		1.70"		1.80"		1.90"		2.00"		
	rpm	bhp	rpm	bhp	rpm	bhp	rpm	bhp	rpm	bhp	rpm	bhp	rpm	bhp	rpm	bhp	rpm	bhp	rpm	bhp	
2400	1093	0.88	1119	0.95	1145	1.02	1171	1.10	1195	1.17	1219	1.25	1241	1.32	1264	1.40	1286	1.48	1308	1.56	
2700	1156	1.03	1181	1.10	1207	1.18	1232	1.26	1255	1.34	1278	1.42	1301	1.50	1323	1.58	1344	1.67	1365	1.75	
3000	1219	1.20	1245	1.28	1270	1.36	1294	1.45	1318	1.53	1340	1.62	1362	1.71	1384	1.79	1406	1.88	1426	1.97	
3300	1286	1.39	1310	1.48	1335	1.57	1358	1.66	1381	1.75	1403	1.84	1425	1.93	1446	2.03	1467	2.12	1487	2.21	
3600	1353	1.61	1377	1.70	1400	1.79	1424	1.89	1445	1.99	1467	2.08	1488	2.18	1509	2.28	1530	2.38	1550	2.49	

**Notes:**

1. For direct drive evaporator fan speed (rpm), refer to the applicable table in the fan performance section.
2. Data includes pressure drop due to standard filters and wet coils.
3. To determine static pressure drop due to other options/accessories, refer to the applicable table in the fan performance section.
4. Direct drive fan motor heat (MBh) = 2.7912 x fan bhp + 0.1388
5. Factory supplied motors, in commercial equipment, are definite purpose motors, specifically designed and tested to operate reliably and continuously at all cataloged conditions. Using the full horsepower range of our fan motors as shown in our tabular data will not result in nuisance tripping or premature motor failure. Our product's warranty will not be affected.

## Evaporator Fan Performance

**Table 61. Direct drive evaporator fan performance - 7.5 tons high efficiency dual fuel low/medium heat - DHC092H3,4,W horizontal airflow**

External Static Pressure (Inches of Water)																					
cfm	.10"		.20"		.30"		.40"		.50"		.60"		.70"		.80"		.90"		1.00"		
	rpm	bhp	rpm	bhp	rpm	bhp	rpm	bhp	rpm	bhp	rpm	bhp	rpm	bhp	rpm	bhp	rpm	bhp	rpm	bhp	
2400	718	0.22	762	0.27	805	0.33	844	0.39	881	0.45	915	0.51	947	0.57	978	0.64	1007	0.70	1035	0.77	
2700	796	0.30	836	0.36	875	0.42	913	0.49	947	0.55	980	0.62	1011	0.69	1041	0.76	1069	0.83	1096	0.90	
3000	876	0.39	913	0.46	948	0.53	983	0.60	1016	0.67	1047	0.75	1077	0.82	1106	0.90	1133	0.97	1160	1.05	
3300	956	0.51	990	0.58	1022	0.65	1055	0.73	1086	0.81	1116	0.89	1145	0.98	1172	1.06	1198	1.14	1224	1.22	
3600	1037	0.64	1069	0.73	1099	0.81	1128	0.88	1157	0.96	1186	1.05	1213	1.14	1240	1.23	1266	1.33	1290	1.41	
External Static Pressure (Inches of Water)																					
cfm	1.10"		1.20"		1.30"		1.40"		1.50"		1.60"		1.70"		1.80"		1.90"		2.00"		
	rpm	bhp	rpm	bhp	rpm	bhp	rpm	bhp	rpm	bhp	rpm	bhp	rpm	bhp	rpm	bhp	rpm	bhp	rpm	bhp	
2400	1062	0.84	1089	0.91	1114	0.98	1138	1.05	1162	1.12	1185	1.19	1208	1.27	1230	1.34	1250	1.41	1271	1.49	
2700	1123	0.97	1149	1.05	1173	1.12	1197	1.20	1220	1.28	1243	1.35	1266	1.43	1287	1.51	1307	1.59	1329	1.68	
3000	1185	1.13	1210	1.21	1234	1.29	1257	1.37	1280	1.45	1302	1.53	1324	1.62	1345	1.71	1366	1.79	1386	1.88	
3300	1249	1.30	1273	1.39	1297	1.47	1319	1.56	1342	1.65	1363	1.74	1384	1.83	1406	1.92	1425	2.01	1445	2.10	
3600	1314	1.50	1338	1.59	1361	1.69	1383	1.78	1405	1.87	1425	1.96	1446	2.06	1467	2.16	1487	2.26	1506	2.35	

**Notes:**

1. For direct drive evaporator fan speed (rpm), refer to the applicable table in the fan performance section.
2. Data includes pressure drop due to standard filters and wet coils.
3. To determine static pressure drop due to other options/accessories, refer to the applicable table in the fan performance section.
4. Direct drive fan motor heat (MBh) = 2.7912 x fan bhp + 0.1388
5. Factory supplied motors, in commercial equipment, are definite purpose motors, specifically designed and tested to operate reliably and continuously at all cataloged conditions. Using the full horsepower range of our fan motors as shown in our tabular data will not result in nuisance tripping or premature motor failure. Our product's warranty will not be affected.



## Evaporator Fan Performance

**Table 62. Direct drive evaporator fan performance - 7.5 tons high efficiency dual fuel high heat - DHC092H3,4,W downflow airflow**

External Static Pressure (Inches of Water)																					
cfm	.10"		.20"		.30"		.40"		.50"		.60"		.70"		.80"		.90"		1.00"		
	rpm	bhp	rpm	bhp	rpm	bhp	rpm	bhp	rpm	bhp	rpm	bhp	rpm	bhp	rpm	bhp	rpm	bhp	rpm	bhp	
2400	759	0.29	800	0.34	845	0.41	884	0.47	920	0.53	956	0.60	989	0.66	1022	0.73	1053	0.80	1083	0.87	
2700	844	0.39	879	0.45	918	0.52	958	0.60	992	0.66	1024	0.74	1057	0.81	1087	0.88	1117	0.95	1145	1.03	
3000	931	0.52	962	0.59	995	0.66	1031	0.74	1067	0.82	1098	0.90	1127	0.98	1156	1.06	1184	1.14	1211	1.22	
3300	1018	0.68	1046	0.75	1075	0.82	1107	0.91	1140	1.00	1172	1.09	1201	1.17	1227	1.26	1254	1.35	1279	1.43	
3600	1106	0.87	1132	0.95	1157	1.02	1185	1.11	1215	1.21	1245	1.30	1275	1.40	1301	1.49	1326	1.59	1350	1.68	
External Static Pressure (Inches of Water)																					
cfm	1.10"		1.20"		1.30"		1.40"		1.50"		1.60"		1.70"		1.80"		1.90"		2.00"		
	rpm	bhp	rpm	bhp	rpm	bhp	rpm	bhp	rpm	bhp	rpm	bhp	rpm	bhp	rpm	bhp	rpm	bhp	rpm	bhp	
2400	1113	0.94	1141	1.02	1169	1.09	1194	1.17	1220	1.24	1245	1.32	1270	1.40	1292	1.48	1315	1.56	1338	1.64	
2700	1174	1.11	1202	1.19	1228	1.27	1254	1.35	1278	1.43	1303	1.52	1328	1.60	1350	1.68	1373	1.77	1395	1.86	
3000	1238	1.30	1264	1.38	1289	1.47	1314	1.55	1339	1.64	1363	1.73	1386	1.82	1409	1.92	1431	2.01	1454	2.10	
3300	1306	1.52	1330	1.61	1355	1.70	1378	1.79	1402	1.88	1425	1.98	1448	2.08	1470	2.17	1492	2.27	1513	2.37	
3600	1374	1.78	1398	1.87	1422	1.97	1445	2.06	1467	2.16	1489	2.26	1510	2.36	1532	2.46	1553	2.56	1575	2.67	

**Notes:**

1. For direct drive evaporator fan speed (rpm), refer to the applicable table in the fan performance section.
2. Data includes pressure drop due to standard filters and wet coils.
3. To determine static pressure drop due to other options/accessories, refer to the applicable table in the fan performance section.
4. Direct drive fan motor heat (MBh) = 2.7912 x fan bhp + 0.1388
5. Factory supplied motors, in commercial equipment, are definite purpose motors, specifically designed and tested to operate reliably and continuously at all cataloged conditions. Using the full horsepower range of our fan motors as shown in our tabular data will not result in nuisance tripping or premature motor failure. Our product's warranty will not be affected.

## Evaporator Fan Performance

**Table 63. Direct drive evaporator fan performance - 7.5 tons high efficiency dual fuel high heat - DHC092H3,4,W horizontal airflow**

External Static Pressure (Inches of Water)																					
cfm	.10"		.20"		.30"		.40"		.50"		.60"		.70"		.80"		.90"		1.00"		
	rpm	bhp	rpm	bhp	rpm	bhp	rpm	bhp	rpm	bhp	rpm	bhp	rpm	bhp	rpm	bhp	rpm	bhp	rpm	bhp	
2400	719	0.24	765	0.30	811	0.36	853	0.42	883	0.47	888	0.48	981	0.66	1003	0.71	1020	0.75	1033	0.78	
2700	797	0.32	840	0.38	880	0.46	920	0.53	958	0.60	992	0.67	996	0.68	1072	0.85	1107	0.94	1126	1.00	
3000	875	0.42	916	0.49	952	0.57	989	0.65	1025	0.73	1059	0.80	1091	0.89	1105	0.93	1108	0.94	1198	1.19	
3300	955	0.55	993	0.62	1027	0.70	1060	0.79	1093	0.88	1126	0.96	1157	1.05	1186	1.13	1213	1.22	1216	1.24	
3600	1035	0.69	1070	0.77	1103	0.86	1133	0.95	1163	1.05	1194	1.15	1224	1.24	1253	1.33	1280	1.42	1306	1.52	
External Static Pressure (Inches of Water)																					
cfm	1.10"		1.20"		1.30"		1.40"		1.50"		1.60"		1.70"		1.80"		1.90"		2.00"		
	rpm	bhp	rpm	bhp	rpm	bhp	rpm	bhp	rpm	bhp	rpm	bhp	rpm	bhp	rpm	bhp	rpm	bhp	rpm	bhp	
2400	1045	0.81	1055	0.84	1065	0.87	1074	0.90	1083	0.92	1091	0.95	1099	0.97	1106	1.00	1113	1.02	1119	1.04	
2700	1142	1.04	1154	1.09	1166	1.12	1176	1.16	1186	1.19	1195	1.22	1203	1.26	1211	1.28	1218	1.31	1226	1.34	
3000	1228	1.29	1247	1.35	1261	1.40	1274	1.45	1285	1.50	1295	1.54	1304	1.58	1313	1.61	1321	1.65	1329	1.69	
3300	1220	1.25	1314	1.57	1345	1.69	1363	1.76	1377	1.83	1391	1.89	1402	1.94	1412	1.98	1421	2.03	1430	2.08	
3600	1324	1.59	1327	1.61	1330	1.63	1333	1.64	1456	2.14	1476	2.24	1492	2.31	1505	2.38	1516	2.44	1527	2.50	

**Notes:**

1. For direct drive evaporator fan speed (rpm), refer to the applicable table in the fan performance section.
2. Data includes pressure drop due to standard filters and wet coils.
3. To determine static pressure drop due to other options/accessories, refer to the applicable table in the fan performance section.
4. Direct drive fan motor heat (MBh) = 2.7912 x fan bhp + 0.1388
5. Factory supplied motors, in commercial equipment, are definite purpose motors, specifically designed and tested to operate reliably and continuously at all cataloged conditions. Using the full horsepower range of our fan motors as shown in our tabular data will not result in nuisance tripping or premature motor failure. Our product's warranty will not be affected.



## Evaporator Fan Performance

**Table 64. Direct drive evaporator fan performance - 8.5 tons high efficiency - WHC102H3,4,W downflow airflow**

External Static Pressure (Inches of Water)																					
cfm	.10"		.20"		.30"		.40"		.50"		.60"		.70"		.80"		.90"		1.00"		
	rpm	bhp	rpm	bhp	rpm	bhp	rpm	bhp	rpm	bhp	rpm	bhp	rpm	bhp	rpm	bhp	rpm	bhp	rpm	bhp	
2720	812	0.31	857	0.37	899	0.44	935	0.50	976	0.58	1011	0.65	1040	0.72	1068	0.78	1099	0.85	1129	0.92	
3060	904	0.42	942	0.49	983	0.57	1017	0.64	1049	0.71	1086	0.80	1119	0.89	1149	0.96	1174	1.03	1197	1.10	
3400	997	0.55	1030	0.63	1066	0.71	1103	0.81	1132	0.89	1160	0.96	1193	1.06	1225	1.16	1254	1.25	1279	1.33	
3740	1090	0.72	1120	0.80	1152	0.89	1185	0.99	1218	1.09	1244	1.17	1269	1.25	1298	1.36	1329	1.47	1356	1.57	
4080	1183	0.92	1211	1.01	1240	1.10	1270	1.20	1301	1.31	1330	1.42	1354	1.51	1377	1.60	1402	1.70	1430	1.82	
External Static Pressure (Inches of Water)																					
cfm	1.10"		1.20"		1.30"		1.40"		1.50"		1.60"		1.70"		1.80"		1.90"		2.00"		
	rpm	bhp	rpm	bhp	rpm	bhp	rpm	bhp	rpm	bhp	rpm	bhp	rpm	bhp	rpm	bhp	rpm	bhp	rpm	bhp	
2720	1158	0.99	1186	1.05	1213	1.11	1238	1.18	1264	1.24	1289	1.30	1313	1.36	1336	1.42	1359	1.47	1382	1.53	
3060	1226	1.18	1253	1.26	1279	1.33	1305	1.41	1329	1.48	1353	1.55	1377	1.63	1400	1.70	1422	1.76	1444	1.83	
3400	1301	1.40	1323	1.48	1347	1.56	1372	1.65	1396	1.74	1421	1.83	1444	1.91	1465	1.99	1487	2.07	1509	2.15	
3740	1382	1.67	1406	1.76	1426	1.84	1445	1.92	1465	2.01	1489	2.11	1510	2.20	1533	2.30	1554	2.39	1576	2.49	
4080	1457	1.94	1482	2.05	1506	2.16	1527	2.26	1546	2.35	1565	2.44	1583	2.53	1602	2.63	1623	2.73	1643	2.84	

**Notes:**

1. For direct drive evaporator fan speed (rpm), refer to the applicable table in the fan performance section.
2. Data includes pressure drop due to standard filters and wet coils.
3. To determine static pressure drop due to other options/accessories, refer to the applicable table in the fan performance section.
4. Direct drive fan motor heat (MBh) = 2.7912 x fan bhp + 0.1388
5. Factory supplied motors, in commercial equipment, are definite purpose motors, specifically designed and tested to operate reliably and continuously at all cataloged conditions. Using the full horsepower range of our fan motors as shown in our tabular data will not result in nuisance tripping or premature motor failure. Our product's warranty will not be affected.



## Evaporator Fan Performance

**Table 65. Direct drive evaporator fan performance - 8.5 tons high efficiency - WHC102H3,4,W horizontal airflow**

External Static Pressure (Inches of Water)																					
cfm	.10"		.20"		.30"		.40"		.50"		.60"		.70"		.80"		.90"		1.00"		
	rpm	bhp	rpm	bhp	rpm	bhp	rpm	bhp	rpm	bhp	rpm	bhp	rpm	bhp	rpm	bhp	rpm	bhp	rpm	bhp	
2720	821	0.31	864	0.38	911	0.45	947	0.52	982	0.58	1015	0.65	1046	0.71	1077	0.78	1107	0.85	1137	0.93	
3060	914	0.43	951	0.50	993	0.58	1032	0.66	1063	0.73	1095	0.81	1125	0.88	1153	0.95	1181	1.03	1208	1.10	
3400	1008	0.57	1041	0.64	1076	0.73	1115	0.82	1148	0.91	1177	0.99	1204	1.07	1232	1.15	1259	1.24	1284	1.32	
3740	1103	0.75	1132	0.82	1163	0.91	1197	1.01	1232	1.11	1262	1.21	1288	1.30	1313	1.38	1339	1.47	1364	1.57	
4080	1198	0.95	1225	1.04	1253	1.13	1281	1.22	1314	1.33	1345	1.45	1372	1.55	1397	1.65	1420	1.75	1444	1.84	
External Static Pressure (Inches of Water)																					
cfm	1.10"		1.20"		1.30"		1.40"		1.50"		1.60"		1.70"		1.80"		1.90"		2.00"		
	rpm	bhp	rpm	bhp	rpm	bhp	rpm	bhp	rpm	bhp	rpm	bhp	rpm	bhp	rpm	bhp	rpm	bhp	rpm	bhp	
2720	1165	1.00	1193	1.07	1220	1.15	1245	1.22	1271	1.30	1296	1.38	1322	1.47	1344	1.55	1368	1.63	1391	1.72	
3060	1235	1.18	1261	1.26	1288	1.34	1313	1.43	1337	1.51	1361	1.59	1385	1.68	1408	1.77	1431	1.86	1453	1.95	
3400	1310	1.40	1334	1.48	1359	1.57	1382	1.66	1406	1.75	1430	1.84	1453	1.93	1474	2.02	1496	2.12	1518	2.21	
3740	1388	1.66	1411	1.75	1433	1.83	1456	1.93	1477	2.02	1500	2.11	1522	2.21	1544	2.31	1565	2.41	1586	2.51	
4080	1467	1.95	1489	2.04	1512	2.14	1533	2.24	1554	2.34	1575	2.43	1594	2.53	1616	2.64	1636	2.74	-	-	

**Notes:**

1. For direct drive evaporator fan speed (rpm), refer to the applicable table in the fan performance section.
2. Data includes pressure drop due to standard filters and wet coils.
3. To determine static pressure drop due to other options/accessories, refer to the applicable table in the fan performance section.
4. Direct drive fan motor heat (MBh) = 2.7912 x fan bhp + 0.1388
5. Factory supplied motors, in commercial equipment, are definite purpose motors, specifically designed and tested to operate reliably and continuously at all cataloged conditions. Using the full horsepower range of our fan motors as shown in our tabular data will not result in nuisance tripping or premature motor failure. Our product's warranty will not be affected.



## Evaporator Fan Performance

**Table 66. Direct drive evaporator fan performance - 8.5 tons high efficiency dual fuel low/medium heat - DHC102H3,4,W downflow airflow**

External Static Pressure (Inches of Water)																					
cfm	.10"		.20"		.30"		.40"		.50"		.60"		.70"		.80"		.90"		1.00"		
	rpm	bhp	rpm	bhp	rpm	bhp	rpm	bhp	rpm	bhp	rpm	bhp	rpm	bhp	rpm	bhp	rpm	bhp	rpm	bhp	
2720	804	0.27	849	0.31	889	0.36	927	0.42	962	0.47	995	0.52	1027	0.58	1057	0.64	1085	0.70	1113	0.76	
3060	894	0.37	934	0.41	972	0.47	1007	0.53	1040	0.59	1072	0.65	1102	0.71	1131	0.77	1159	0.83	1186	0.90	
3400	984	0.49	1021	0.54	1056	0.60	1090	0.66	1121	0.73	1151	0.80	1180	0.87	1207	0.93	1234	0.99	1260	1.06	
3740	1075	0.64	1110	0.70	1142	0.76	1173	0.82	1203	0.89	1232	0.97	1260	1.05	1286	1.12	1312	1.19	1336	1.26	
4080	1166	0.82	1198	0.88	1229	0.94	1259	1.01	1287	1.09	1314	1.16	1340	1.24	1366	1.33	1390	1.42	1414	1.49	
External Static Pressure (Inches of Water)																					
cfm	1.10"		1.20"		1.30"		1.40"		1.50"		1.60"		1.70"		1.80"		1.90"		2.00"		
	rpm	bhp	rpm	bhp	rpm	bhp	rpm	bhp	rpm	bhp	rpm	bhp	rpm	bhp	rpm	bhp	rpm	bhp	rpm	bhp	
2720	1140	0.82	1165	0.87	1191	0.93	1215	0.99	1238	1.05	1261	1.11	1284	1.18	1305	1.25	1327	1.32	1347	1.39	
3060	1211	0.96	1237	1.04	1260	1.10	1284	1.17	1307	1.23	1329	1.29	1351	1.35	1372	1.42	1393	1.49	1414	1.57	
3400	1284	1.13	1309	1.20	1332	1.28	1356	1.36	1378	1.44	1400	1.51	1420	1.58	1442	1.65	1461	1.72	1481	1.79	
3740	1360	1.33	1383	1.40	1406	1.48	1428	1.56	1451	1.64	1472	1.73	1492	1.81	1512	1.90	1532	1.98	1551	2.06	
4080	1437	1.56	1460	1.64	1482	1.72	1503	1.80	1525	1.88	1545	1.97	1565	2.05	1586	2.15	1604	2.23	1623	2.33	

**Notes:**

1. For direct drive evaporator fan speed (rpm), refer to the applicable table in the fan performance section.
2. Data includes pressure drop due to standard filters and wet coils.
3. To determine static pressure drop due to other options/accessories, refer to the applicable table in the fan performance section.
4. Direct drive fan motor heat (MBh) = 2.7912 x fan bhp + 0.1388
5. Factory supplied motors, in commercial equipment, are definite purpose motors, specifically designed and tested to operate reliably and continuously at all cataloged conditions. Using the full horsepower range of our fan motors as shown in our tabular data will not result in nuisance tripping or premature motor failure. Our product's warranty will not be affected.

## Evaporator Fan Performance

**Table 67. Direct drive evaporator fan performance - 8.5 tons high efficiency dual fuel low/medium heat - DHC102H3,4,W horizontal airflow**

External Static Pressure (Inches of Water)																					
cfm	.10"		.20"		.30"		.40"		.50"		.60"		.70"		.80"		.90"		1.00"		
	rpm	bhp	rpm	bhp	rpm	bhp	rpm	bhp	rpm	bhp	rpm	bhp	rpm	bhp	rpm	bhp	rpm	bhp	rpm	bhp	
2720	815	0.33	847	0.40	886	0.47	926	0.54	962	0.61	995	0.69	1027	0.76	1058	0.84	1090	0.91	1122	0.99	
3060	909	0.45	938	0.52	968	0.60	1004	0.68	1040	0.76	1072	0.84	1103	0.93	1132	1.01	1160	1.10	1187	1.18	
3400	1003	0.59	1030	0.68	1056	0.76	1085	0.85	1118	0.94	1150	1.03	1179	1.12	1207	1.21	1234	1.30	1261	1.40	
3740	1099	0.77	1123	0.86	1147	0.96	1170	1.05	1198	1.15	1227	1.24	1257	1.34	1285	1.44	1311	1.54	1336	1.64	
4080	1194	0.98	1217	1.08	1239	1.18	1260	1.28	1282	1.39	1308	1.50	1335	1.60	1363	1.71	1388	1.81	1413	1.92	
External Static Pressure (Inches of Water)																					
cfm	1.10"		1.20"		1.30"		1.40"		1.50"		1.60"		1.70"		1.80"		1.90"		2.00"		
	rpm	bhp	rpm	bhp	rpm	bhp	rpm	bhp	rpm	bhp	rpm	bhp	rpm	bhp	rpm	bhp	rpm	bhp	rpm	bhp	
2720	1154	1.07	1184	1.15	1212	1.23	1238	1.31	1262	1.39	1285	1.47	1307	1.55	1329	1.63	1352	1.71	1373	1.79	
3060	1214	1.27	1244	1.35	1273	1.44	1301	1.53	1327	1.62	1353	1.72	1376	1.80	1398	1.89	1420	1.98	1440	2.07	
3400	1285	1.49	1310	1.59	1335	1.69	1360	1.78	1387	1.87	1412	1.97	1439	2.07	1462	2.17	1486	2.27	1508	2.38	
3740	1361	1.75	1384	1.85	1407	1.96	1430	2.06	1452	2.17	1474	2.27	1498	2.37	1522	2.48	1545	2.58	1569	2.70	
4080	1437	2.03	1460	2.14	1482	2.26	1503	2.37	1524	2.48	1546	2.60	1566	2.71	1587	2.83	1608	2.95	-	-	

**Notes:**

1. For direct drive evaporator fan speed (rpm), refer to the applicable table in the fan performance section.
2. Data includes pressure drop due to standard filters and wet coils.
3. To determine static pressure drop due to other options/accessories, refer to the applicable table in the fan performance section.
4. Direct drive fan motor heat (MBh) = 2.7912 x fan bhp + 0.1388
5. Factory supplied motors, in commercial equipment, are definite purpose motors, specifically designed and tested to operate reliably and continuously at all cataloged conditions. Using the full horsepower range of our fan motors as shown in our tabular data will not result in nuisance tripping or premature motor failure. Our product's warranty will not be affected.



## Evaporator Fan Performance

**Table 68. Direct drive evaporator fan performance - 8.5 tons high efficiency dual fuel high heat - DHC102H3,4,W downflow airflow**

External Static Pressure (Inches of Water)																					
cfm	.10"		.20"		.30"		.40"		.50"		.60"		.70"		.80"		.90"		1.00"		
	rpm	bhp	rpm	bhp	rpm	bhp	rpm	bhp	rpm	bhp	rpm	bhp	rpm	bhp	rpm	bhp	rpm	bhp	rpm	bhp	
2720	850	0.40	884	0.46	923	0.53	963	0.61	998	0.68	1029	0.75	1061	0.82	1091	0.89	1121	0.96	1149	1.04	
3060	948	0.55	978	0.62	1011	0.69	1046	0.77	1081	0.86	1112	0.94	1141	1.02	1169	1.09	1198	1.18	1224	1.26	
3400	1047	0.74	1074	0.81	1102	0.88	1132	0.97	1165	1.07	1196	1.16	1226	1.25	1251	1.34	1277	1.42	1302	1.51	
3740	1147	0.96	1171	1.04	1196	1.12	1222	1.21	1250	1.31	1280	1.42	1309	1.52	1336	1.62	1361	1.72	1384	1.81	
4080	1246	1.23	1269	1.32	1292	1.41	1315	1.50	1339	1.60	1365	1.71	1392	1.82	1419	1.94	1445	2.05	1468	2.15	
External Static Pressure (Inches of Water)																					
cfm	1.10"		1.20"		1.30"		1.40"		1.50"		1.60"		1.70"		1.80"		1.90"		2.00"		
	rpm	bhp	rpm	bhp	rpm	bhp	rpm	bhp	rpm	bhp	rpm	bhp	rpm	bhp	rpm	bhp	rpm	bhp	rpm	bhp	
2720	1178	1.12	1205	1.20	1232	1.28	1258	1.37	1283	1.45	1307	1.53	1330	1.62	1354	1.71	1377	1.79	1399	1.88	
3060	1251	1.34	1276	1.43	1302	1.51	1327	1.60	1352	1.69	1376	1.79	1398	1.88	1422	1.97	1444	2.07	1465	2.16	
3400	1327	1.60	1352	1.69	1377	1.79	1400	1.88	1423	1.98	1446	2.07	1468	2.17	1490	2.27	1513	2.38	1533	2.47	
3740	1407	1.91	1431	2.01	1454	2.10	1476	2.20	1498	2.30	1519	2.40	1541	2.51	1562	2.61	1582	2.72	-	-	
4080	1491	2.26	1512	2.36	1533	2.47	1554	2.57	1576	2.68	1597	2.79	-	-	-	-	-	-	-	-	

**Notes:**

1. For direct drive evaporator fan speed (rpm), refer to the applicable table in the fan performance section.
2. Data includes pressure drop due to standard filters and wet coils.
3. To determine static pressure drop due to other options/accessories, refer to the applicable table in the fan performance section.
4. Direct drive fan motor heat (MBh) = 2.7912 x fan bhp + 0.1388
5. Factory supplied motors, in commercial equipment, are definite purpose motors, specifically designed and tested to operate reliably and continuously at all cataloged conditions. Using the full horsepower range of our fan motors as shown in our tabular data will not result in nuisance tripping or premature motor failure. Our product's warranty will not be affected.

## Evaporator Fan Performance

**Table 69. Direct drive evaporator fan performance - 8.5 tons high efficiency dual fuel high heat - DHC102H3,4,W horizontal airflow**

External Static Pressure (Inches of Water)																					
cfm	.10"		.20"		.30"		.40"		.50"		.60"		.70"		.80"		.90"		1.00"		
	rpm	bhp	rpm	bhp	rpm	bhp	rpm	bhp	rpm	bhp	rpm	bhp	rpm	bhp	rpm	bhp	rpm	bhp	rpm	bhp	
2720	817	0.35	858	0.41	897	0.48	937	0.56	975	0.64	1009	0.71	1042	0.78	1073	0.86	1106	0.94	1137	1.02	
3060	908	0.47	947	0.55	980	0.62	1016	0.70	1052	0.79	1086	0.88	1117	0.96	1147	1.04	1176	1.13	1204	1.22	
3400	1001	0.62	1037	0.71	1068	0.79	1099	0.88	1131	0.97	1164	1.07	1195	1.17	1224	1.26	1251	1.35	1277	1.44	
3740	1094	0.81	1127	0.91	1158	1.00	1185	1.09	1214	1.19	1243	1.29	1272	1.39	1301	1.50	1329	1.61	1354	1.71	
4080	1188	1.03	1218	1.14	1248	1.24	1274	1.34	1299	1.44	1325	1.54	1352	1.66	1379	1.77	1406	1.89	1432	2.01	
External Static Pressure (Inches of Water)																					
cfm	1.10"		1.20"		1.30"		1.40"		1.50"		1.60"		1.70"		1.80"		1.90"		2.00"		
	rpm	bhp	rpm	bhp	rpm	bhp	rpm	bhp	rpm	bhp	rpm	bhp	rpm	bhp	rpm	bhp	rpm	bhp	rpm	bhp	
2720	1166	1.10	1193	1.18	1220	1.26	1245	1.34	1269	1.42	1294	1.50	1318	1.59	1340	1.67	1364	1.76	1385	1.84	
3060	1233	1.31	1261	1.40	1288	1.49	1314	1.58	1338	1.67	1362	1.76	1384	1.85	1408	1.94	1429	2.03	1450	2.12	
3400	1304	1.54	1329	1.63	1355	1.73	1380	1.83	1406	1.94	1430	2.04	1453	2.14	1475	2.23	1497	2.34	1518	2.43	
3740	1378	1.81	1402	1.91	1426	2.01	1450	2.12	1473	2.22	1496	2.33	1520	2.45	1542	2.55	1565	2.67	1587	2.78	
4080	1457	2.12	1479	2.23	1502	2.34	1524	2.45	1546	2.56	1567	2.68	1590	2.79	-	-	-	-	-	-	

**Notes:**

1. For direct drive evaporator fan speed (rpm), refer to the applicable table in the fan performance section.
2. Data includes pressure drop due to standard filters and wet coils.
3. To determine static pressure drop due to other options/accessories, refer to the applicable table in the fan performance section.
4. Direct drive fan motor heat (MBh) = 2.7912 x fan bhp + 0.1388
5. Factory supplied motors, in commercial equipment, are definite purpose motors, specifically designed and tested to operate reliably and continuously at all cataloged conditions. Using the full horsepower range of our fan motors as shown in our tabular data will not result in nuisance tripping or premature motor failure. Our product's warranty will not be affected.



## Evaporator Fan Performance

**Table 70. Direct drive evaporator fan performance - 10 tons high efficiency - WHC120H3,4,W downflow airflow**

External Static Pressure (Inches of Water)																					
cfm	.10"		.20"		.30"		.40"		.50"		.60"		.70"		.80"		.90"		1.00"		
	rpm	bhp	rpm	bhp	rpm	bhp	rpm	bhp	rpm	bhp	rpm	bhp	rpm	bhp	rpm	bhp	rpm	bhp	rpm	bhp	
3200	942	0.47	978	0.54	1017	0.63	1053	0.71	1082	0.78	1116	0.87	1150	0.96	1181	1.04	1207	1.12	1231	1.19	
3600	1051	0.65	1083	0.73	1116	0.81	1152	0.91	1183	1.00	1209	1.08	1237	1.17	1268	1.27	1298	1.38	1325	1.47	
4000	1161	0.87	1190	0.96	1219	1.05	1249	1.15	1282	1.26	1310	1.36	1334	1.45	1357	1.54	1385	1.65	1412	1.76	
4400	1272	1.13	1298	1.23	1324	1.33	1351	1.44	1379	1.54	1409	1.67	1435	1.79	1457	1.88	1478	1.98	1501	2.08	
4800	1383	1.45	1407	1.56	1431	1.66	1455	1.78	1480	1.89	1506	2.01	1532	2.14	1558	2.28	1579	2.39	1599	2.49	
External Static Pressure (Inches of Water)																					
cfm	1.10"		1.20"		1.30"		1.40"		1.50"		1.60"		1.70"		1.80"		1.90"		2.00"		
	rpm	bhp	rpm	bhp	rpm	bhp	rpm	bhp	rpm	bhp	rpm	bhp	rpm	bhp	rpm	bhp	rpm	bhp	rpm	bhp	
3200	1254	1.26	1282	1.35	1307	1.43	1332	1.51	1357	1.59	1381	1.66	1404	1.74	1427	1.82	1449	1.89	1471	1.96	
3600	1350	1.56	1372	1.64	1392	1.72	1412	1.80	1437	1.90	1460	1.99	1483	2.08	1504	2.17	1526	2.26	1548	2.35	
4000	1440	1.88	1464	1.98	1488	2.08	1508	2.18	1527	2.26	1545	2.35	1564	2.44	1586	2.55	1606	2.65	1627	2.75	
4400	1526	2.20	1552	2.33	1576	2.46	1600	2.58	1621	2.69	1642	2.80	1660	2.90	-	-	-	-	-	-	
4800	1618	2.60	1639	2.71	1663	2.85	-	-	-	-	-	-	-	-	-	-	-	-	-	-	

**Notes:**

1. For direct drive evaporator fan speed (rpm), refer to the applicable table in the fan performance section.
2. Data includes pressure drop due to standard filters and wet coils.
3. To determine static pressure drop due to other options/accessories, refer to the applicable table in the fan performance section.
4. Direct drive fan motor heat (MBh) = 2.7912 x fan bhp + 0.1388
5. Factory supplied motors, in commercial equipment, are definite purpose motors, specifically designed and tested to operate reliably and continuously at all cataloged conditions. Using the full horsepower range of our fan motors as shown in our tabular data will not result in nuisance tripping or premature motor failure. Our product's warranty will not be affected.
6. For electric heat applications, minimum airflow is set to 320 cfm/ton, unless specified otherwise, values found in electric heat temperature rise table.

## Evaporator Fan Performance

**Table 71. Direct drive evaporator fan performance - 10 tons high efficiency - WHC120H3,4,W horizontal airflow**

External Static Pressure (Inches of Water)																					
cfm	.10"		.20"		.30"		.40"		.50"		.60"		.70"		.80"		.90"		1.00"		
	rpm	bhp	rpm	bhp	rpm	bhp	rpm	bhp	rpm	bhp	rpm	bhp	rpm	bhp	rpm	bhp	rpm	bhp	rpm	bhp	
3200	953	0.48	988	0.55	1027	0.64	1067	0.73	1098	0.80	1128	0.88	1157	0.96	1186	1.03	1213	1.11	1239	1.19	
3600	1064	0.67	1095	0.75	1126	0.83	1163	0.93	1198	1.03	1226	1.11	1253	1.20	1280	1.29	1306	1.37	1331	1.46	
4000	1175	0.90	1203	0.98	1231	1.07	1260	1.17	1294	1.28	1327	1.39	1353	1.49	1377	1.58	1401	1.68	1425	1.78	
4400	1288	1.18	1313	1.27	1338	1.36	1364	1.46	1392	1.57	1422	1.70	1452	1.82	1477	1.93	1500	2.04	1522	2.14	
4800	1400	1.51	1423	1.61	1446	1.71	1470	1.82	1494	1.93	1519	2.05	1547	2.18	1575	2.32	1600	2.45	1622	2.56	

External Static Pressure (Inches of Water)																					
cfm	1.10"		1.20"		1.30"		1.40"		1.50"		1.60"		1.70"		1.80"		1.90"		2.00"		
	rpm	bhp	rpm	bhp	rpm	bhp	rpm	bhp	rpm	bhp	rpm	bhp	rpm	bhp	rpm	bhp	rpm	bhp	rpm	bhp	
3200	1265	1.27	1291	1.35	1316	1.43	1342	1.52	1365	1.60	1389	1.69	1412	1.78	1435	1.87	1458	1.96	1479	2.05	
3600	1355	1.54	1378	1.63	1401	1.72	1425	1.81	1447	1.90	1471	2.00	1492	2.09	1515	2.19	1536	2.28	1557	2.38	
4000	1448	1.87	1471	1.97	1494	2.07	1515	2.16	1536	2.26	1557	2.36	1578	2.46	1598	2.56	1619	2.66	1640	2.77	
4400	1543	2.24	1565	2.35	1586	2.46	1607	2.56	1628	2.67	1647	2.77	1667	2.88	1686	2.98	-	-	-	-	
4800	1642	2.68	1662	2.79	1682	2.91	1701	3.02	-	-	-	-	-	-	-	-	-	-	-	-	

**Notes:**

1. For direct drive evaporator fan speed (rpm), refer to the applicable table in the fan performance section.
2. Data includes pressure drop due to standard filters and wet coils.
3. To determine static pressure drop due to other options/accessories, refer to the applicable table in the fan performance section.
4. Direct drive fan motor heat (MBh) = 2.7912 x fan bhp + 0.1388
5. Factory supplied motors, in commercial equipment, are definite purpose motors, specifically designed and tested to operate reliably and continuously at all cataloged conditions. Using the full horsepower range of our fan motors as shown in our tabular data will not result in nuisance tripping or premature motor failure. Our product's warranty will not be affected.
6. For electric heat applications, minimum airflow is set to 320 cfm/ton, unless specified otherwise, values found in electric heat temperature rise table.



## Evaporator Fan Performance

**Table 72. Direct drive evaporator fan performance - 10 tons high efficiency dual fuel low/medium heat - DHC120H3,4,W downflow airflow**

External Static Pressure (Inches of Water)																					
cfm	.10"		.20"		.30"		.40"		.50"		.60"		.70"		.80"		.90"		1.00"		
	rpm	bhp	rpm	bhp	rpm	bhp	rpm	bhp	rpm	bhp	rpm	bhp	rpm	bhp	rpm	bhp	rpm	bhp	rpm	bhp	
3200	905	0.22	944	0.28	980	0.33	1015	0.39	1047	0.43	1077	0.47	1106	0.51	1135	0.56	1162	0.60	1187	0.65	
3600	1008	0.30	1044	0.36	1077	0.43	1109	0.49	1140	0.55	1168	0.59	1196	0.64	1222	0.69	1249	0.74	1273	0.79	
4000	1112	0.40	1145	0.47	1176	0.54	1205	0.60	1234	0.67	1261	0.74	1288	0.79	1313	0.85	1338	0.90	1362	0.95	
4400	1217	0.52	1247	0.59	1276	0.67	1304	0.74	1330	0.82	1356	0.89	1381	0.97	1406	1.03	1429	1.09	1451	1.14	
4800	1322	0.66	1350	0.74	1377	0.82	1403	0.90	1428	0.98	1452	1.07	1476	1.15	1499	1.23	1522	1.31	1543	1.37	
External Static Pressure (Inches of Water)																					
cfm	1.10"		1.20"		1.30"		1.40"		1.50"		1.60"		1.70"		1.80"		1.90"		2.00"		
	rpm	bhp	rpm	bhp	rpm	bhp	rpm	bhp	rpm	bhp	rpm	bhp	rpm	bhp	rpm	bhp	rpm	bhp	rpm	bhp	
3200	1213	0.69	1236	0.74	1260	0.78	1283	0.83	1306	0.88	1328	0.93	1348	0.97	1369	1.02	1389	1.07	1409	1.12	
3600	1297	0.84	1321	0.89	1343	0.94	1365	0.99	1387	1.04	1409	1.09	1429	1.14	1449	1.20	1469	1.25	1488	1.30	
4000	1385	1.01	1407	1.06	1429	1.12	1450	1.17	1471	1.23	1491	1.28	1512	1.34	1531	1.39	1550	1.45	1570	1.51	
4400	1474	1.20	1495	1.26	1516	1.32	1537	1.38	1557	1.44	1577	1.50	1596	1.56	1615	1.62	1634	1.68	1653	1.75	
4800	1564	1.43	1586	1.49	1606	1.56	1626	1.62	1645	1.68	1665	1.75	1683	1.81	1702	1.88	1720	1.95	1738	2.01	

**Notes:**

1. For direct drive evaporator fan speed (rpm), refer to the applicable table in the fan performance section.
2. Data includes pressure drop due to standard filters and wet coils.
3. To determine static pressure drop due to other options/accessories, refer to the applicable table in the fan performance section.
4. Direct drive fan motor heat (MBh) = 2.7912 x fan bhp + 0.1388
5. Factory supplied motors, in commercial equipment, are definite purpose motors, specifically designed and tested to operate reliably and continuously at all cataloged conditions. Using the full horsepower range of our fan motors as shown in our tabular data will not result in nuisance tripping or premature motor failure. Our product's warranty will not be affected.



## Evaporator Fan Performance

**Table 73. Direct drive evaporator fan performance - 10 tons high efficiency dual fuel low/medium heat - DHC120H3,4,W horizontal airflow**

External Static Pressure (Inches of Water)																					
cfm	.10"		.20"		.30"		.40"		.50"		.60"		.70"		.80"		.90"		1.00"		
	rpm	bhp	rpm	bhp	rpm	bhp	rpm	bhp	rpm	bhp	rpm	bhp	rpm	bhp	rpm	bhp	rpm	bhp	rpm	bhp	
3200	853	0.34	896	0.42	935	0.50	970	0.57	1004	0.65	1037	0.73	1070	0.81	1101	0.90	1130	0.98	1160	1.07	
3600	950	0.47	988	0.55	1025	0.64	1058	0.72	1089	0.81	1120	0.89	1149	0.98	1180	1.08	1209	1.17	1235	1.26	
4000	1049	0.63	1081	0.71	1116	0.81	1148	0.91	1177	1.00	1206	1.09	1233	1.19	1260	1.28	1286	1.38	1314	1.49	
4400	1148	0.81	1176	0.90	1208	1.01	1239	1.12	1267	1.22	1294	1.33	1320	1.42	1344	1.53	1369	1.63	1394	1.74	
4800	1247	1.04	1273	1.14	1301	1.24	1330	1.36	1357	1.48	1384	1.59	1408	1.70	1432	1.81	1455	1.92	1478	2.04	
External Static Pressure (Inches of Water)																					
cfm	1.10"		1.20"		1.30"		1.40"		1.50"		1.60"		1.70"		1.80"		1.90"		2.00"		
	rpm	bhp	rpm	bhp	rpm	bhp	rpm	bhp	rpm	bhp	rpm	bhp	rpm	bhp	rpm	bhp	rpm	bhp	rpm	bhp	
3200	1191	1.16	1221	1.25	1248	1.35	1275	1.44	1300	1.53	1325	1.62	1349	1.72	1373	1.81	1396	1.91	1418	2.01	
3600	1261	1.36	1287	1.45	1315	1.55	1342	1.66	1367	1.76	1394	1.87	1417	1.97	1441	2.08	1463	2.18	1484	2.28	
4000	1339	1.60	1364	1.70	1388	1.80	1411	1.90	1435	2.01	1460	2.12	1484	2.24	1508	2.36	1530	2.47	1553	2.59	
4400	1419	1.86	1443	1.98	1466	2.09	1489	2.20	1510	2.31	1532	2.43	1553	2.54	1575	2.65	1597	2.78	1619	2.9	
4800	1500	2.16	1523	2.28	1546	2.40	1567	2.52	1589	2.65	1611	2.78	1631	2.9	-	-	-	-	-	-	

**Notes:**

1. For direct drive evaporator fan speed (rpm), refer to the applicable table in the fan performance section.
2. Data includes pressure drop due to standard filters and wet coils.
3. To determine static pressure drop due to other options/accessories, refer to the applicable table in the fan performance section.
4. Direct drive fan motor heat (MBh) = 2.7912 x fan bhp + 0.1388
5. Factory supplied motors, in commercial equipment, are definite purpose motors, specifically designed and tested to operate reliably and continuously at all cataloged conditions. Using the full horsepower range of our fan motors as shown in our tabular data will not result in nuisance tripping or premature motor failure. Our product's warranty will not be affected.



## Evaporator Fan Performance

**Table 74. Direct drive evaporator fan performance - 10 tons high efficiency dual fuel high heat - DHC120H3,4,W downflow airflow**

External Static Pressure (Inches of Water)																					
cfm	.10"		.20"		.30"		.40"		.50"		.60"		.70"		.80"		.90"		1.00"		
	rpm	bhp	rpm	bhp	rpm	bhp	rpm	bhp	rpm	bhp	rpm	bhp	rpm	bhp	rpm	bhp	rpm	bhp	rpm	bhp	
3200	900	0.42	939	0.50	972	0.57	1004	0.64	1037	0.72	1069	0.80	1099	0.88	1127	0.95	1155	1.03	1184	1.12	
3600	1005	0.58	1037	0.66	1071	0.74	1099	0.82	1128	0.90	1157	0.99	1186	1.08	1214	1.17	1240	1.26	1265	1.35	
4000	1110	0.77	1138	0.86	1170	0.96	1198	1.05	1223	1.13	1249	1.22	1275	1.32	1302	1.42	1327	1.52	1352	1.62	
4400	1215	1.01	1241	1.10	1268	1.20	1297	1.31	1321	1.41	1344	1.50	1367	1.60	1391	1.71	1415	1.82	1439	1.93	
4800	1321	1.29	1345	1.39	1369	1.49	1395	1.61	1420	1.73	1442	1.83	1463	1.94	1484	2.04	1506	2.16	1529	2.28	
External Static Pressure (Inches of Water)																					
cfm	1.10"		1.20"		1.30"		1.40"		1.50"		1.60"		1.70"		1.80"		1.90"		2.00"		
	rpm	bhp	rpm	bhp	rpm	bhp	rpm	bhp	rpm	bhp	rpm	bhp	rpm	bhp	rpm	bhp	rpm	bhp	rpm	bhp	
3200	1212	1.21	1239	1.29	1266	1.38	1291	1.47	1316	1.56	1342	1.65	1367	1.75	1392	1.84	1415	1.94	1438	2.03	
3600	1290	1.44	1316	1.53	1341	1.63	1365	1.72	1390	1.82	1414	1.92	1436	2.02	1459	2.12	1482	2.22	1506	2.33	
4000	1375	1.72	1398	1.81	1420	1.91	1443	2.01	1466	2.12	1488	2.23	1511	2.33	1534	2.45	1554	2.55	1575	2.66	
4400	1462	2.03	1485	2.15	1506	2.25	1527	2.36	1548	2.47	1567	2.57	1588	2.69	1609	2.80	1631	2.93	-	-	
4800	1550	2.39	1572	2.51	1593	2.63	1614	2.75	1634	2.87	-	-	-	-	-	-	-	-	-	-	

**Notes:**

1. For direct drive evaporator fan speed (rpm), refer to the applicable table in the fan performance section.
2. Data includes pressure drop due to standard filters and wet coils.
3. To determine static pressure drop due to other options/accessories, refer to the applicable table in the fan performance section.
4. Direct drive fan motor heat (MBh) = 2.7912 x fan bhp + 0.1388
5. Factory supplied motors, in commercial equipment, are definite purpose motors, specifically designed and tested to operate reliably and continuously at all cataloged conditions. Using the full horsepower range of our fan motors as shown in our tabular data will not result in nuisance tripping or premature motor failure. Our product's warranty will not be affected.

## Evaporator Fan Performance

**Table 75. Direct drive evaporator fan performance - 10 tons high efficiency dual fuel high heat - DHC120H3,4,W horizontal airflow**

External Static Pressure (Inches of Water)																					
cfm	.10"		.20"		.30"		.40"		.50"		.60"		.70"		.80"		.90"		1.00"		
	rpm	bhp	rpm	bhp	rpm	bhp	rpm	bhp	rpm	bhp	rpm	bhp	rpm	bhp	rpm	bhp	rpm	bhp	rpm	bhp	
3200	868	0.37	906	0.44	943	0.51	980	0.59	1014	0.67	1046	0.74	1078	0.82	1109	0.91	1139	0.99	1168	1.08	
3600	969	0.50	1001	0.58	1035	0.66	1068	0.74	1100	0.83	1131	0.92	1160	1.01	1189	1.10	1217	1.19	1244	1.28	
4000	1070	0.67	1098	0.75	1129	0.84	1159	0.93	1188	1.02	1218	1.12	1245	1.22	1272	1.32	1298	1.41	1324	1.52	
4400	1172	0.87	1197	0.96	1224	1.06	1251	1.16	1279	1.26	1306	1.36	1332	1.46	1358	1.57	1383	1.68	1407	1.79	
4800	1274	1.12	1297	1.21	1321	1.31	1346	1.42	1371	1.53	1396	1.64	1421	1.75	1445	1.86	1469	1.98	1493	2.10	
External Static Pressure (Inches of Water)																					
cfm	1.10"		1.20"		1.30"		1.40"		1.50"		1.60"		1.70"		1.80"		1.90"		2.00"		
	rpm	bhp	rpm	bhp	rpm	bhp	rpm	bhp	rpm	bhp	rpm	bhp	rpm	bhp	rpm	bhp	rpm	bhp	rpm	bhp	
3200	1196	1.16	1225	1.25	1254	1.34	1280	1.43	1306	1.52	1330	1.61	1355	1.71	1378	1.80	1400	1.89	1424	1.99	
3600	1271	1.37	1297	1.47	1323	1.57	1347	1.66	1374	1.77	1398	1.86	1423	1.97	1447	2.07	1470	2.17	1492	2.27	
4000	1349	1.62	1375	1.72	1399	1.83	1422	1.93	1445	2.03	1468	2.14	1491	2.25	1514	2.36	1538	2.48	1561	2.59	
4400	1431	1.90	1455	2.01	1478	2.12	1499	2.23	1523	2.35	1544	2.46	1565	2.57	1587	2.69	1608	2.81	1629	2.92	
4800	1515	2.21	1537	2.33	1559	2.45	1581	2.57	1602	2.69	1623	2.82	1643	2.94	-	-	-	-	-	-	

**Notes:**

1. For direct drive evaporator fan speed (rpm), refer to the applicable table in the fan performance section.
2. Data includes pressure drop due to standard filters and wet coils.
3. To determine static pressure drop due to other options/accessories, refer to the applicable table in the fan performance section.
4. Direct drive fan motor heat (MBh) = 2.7912 x fan bhp + 0.1388
5. Factory supplied motors, in commercial equipment, are definite purpose motors, specifically designed and tested to operate reliably and continuously at all cataloged conditions. Using the full horsepower range of our fan motors as shown in our tabular data will not result in nuisance tripping or premature motor failure. Our product's warranty will not be affected.



# Fan Performance

**Table 76. Standard motor and sheave/fan speed (rpm)**

Tons	Unit Model Number	Fan Sheave	6 Turns Open	5 Turns Open	4 Turns Open	3 Turns Open	2 Turns Open	1 Turn Open	Closed
7.5	WSC092H	AK64x1"	N/A	695	751	807	863	919	975
8.5	WSC102H	AK64x1"	N/A	767	807	847	888	928	1036

**Note:** Factory set at 3 turns open.

**Table 77. Standard motor and low static drive accessory sheave/fan speed (rpm)**

Tons	Unit Model Number	Fan Sheave	6 Turns Open	5 Turns Open	4 Turns Open	3 Turns Open	2 Turns Open	1 Turn Open	Closed
7.5	WSC092H	AK79x1"	N/A	581	626	671	716	761	805
7.5	WSC092H	AK99x1"	N/A	462	497	533	569	604	640
8.5	WSC102H	AK79x1"	N/A	631	676	721	766	811	856
8.5	WSC102H	AK99x1"	N/A	512	548	583	619	654	690

**Note:** Factory set at 3 turns open.

**Table 78. Oversized motor and drive sheave/fan speed (rpm)**

Tons	Unit Model Number	Fan Sheave	6 Turns Open	5 Turns Open	4 Turns Open	3 Turns Open	2 Turns Open	1 Turn Open	Closed
7.5	WSC092H	AK64x1"	N/A	835	891	946	1002	1057	1113
8.5	WSC102H	AK56x1"	N/A	998	1050	1103	1155	1207	1260

**Note:** Factory set at 3 turns open.

**Table 79. Oversized motor and high static drive sheave/fan speed (rpm)**

Tons	Unit Model Number	6 Turns Open	5 Turns Open	4 Turns Open	3 Turns Open	2 Turns Open	1 Turn Open	Closed
7.5	WSC092H	N/A	908	968	1029	1090	1150	1211

**Note:** Factory set at 3 turns open.

**Table 80. Direct drive plenum fan settings (rpm vs. voltage)**

Potentiometer Voltage	Motor RPM
1	N/A
1.25	N/A
1.5	N/A
1.75	N/A
2	N/A
2.25	325
2.5	402
2.75	465
3	544
3.25	630
3.5	716
3.75	775
4	845
4.25	912
4.5	976
4.75	1044
5	1115
5.25	1203
5.5	1253
5.75	1312
6	1368
6.25	1425
6.5	1475
6.75	1533
7	1581
7.25	1615
7.5	1615

**Table 81. Voltage vs. CFM table**

PWM% Value	Potentiometer Voltage (Vdc)	CFM/Ton
70	<0.1	320
75	0.7	347
80	1.25	373
85	1.65	400
90	1.95	427
95	2.17	453
100	>2.4	480

**Note:** Applicable to W/DHC036-060H models



## Fan Performance

**Table 82. Outdoor sound power level - dB (ref. 10 - 12 W)**

Tons	Unit Model Number	Octave Center Frequency								Overall dBA
		63	125	250	500	1000	2000	4000	8000	
3	WSC036H	84	81	80	79	76	74	69	63	81
4	WSC048H	81	85	81	81	77	72	69	65	82
5	WSC060H	90	90	84	85	83	78	73	68	87
3	W/DHC036H	84	81	80	79	76	74	69	63	81
4	W/DHC048H	90	90	84	85	83	78	73	68	87
5	W/DHC060H	90	90	84	85	83	78	73	68	87
7.5	WSC092H	85	86	84	84	81	76	72	66	86
8.5	WSC102H	81	89	83	83	81	76	72	66	85
10	WSC120H	86	90	85	83	81	76	72	66	86
6	W/DHC074H	87	87	84	84	81	75	71	66	86
7.5	W/DHC092H	82	89	85	84	81	76	72	67	86
8.5	W/DHC102H	83	87	85	83	80	75	70	65	85
10	W/DHC120H	88	86	87	83	79	75	70	63	85

Note: Tests follow AHRI270-2015.

**Table 83. Static pressure drop through accessories (inches water column)**

Tons	Unit Model Number	cfm	Standard Filters <sup>(a)</sup>	2" MERV 8 Filter	2" MERV 13 Filter	Economizer with OA/RA Dampers <sup>(b)</sup>						Electric Heater Accessory (kW) <sup>(c),(d)</sup>			
						100% OA	100% RA	100% OA	100% RA	100% OA	100% RA	5-6	9-18	23-36	54
						Downflow		Low Leak <sup>(e)</sup>		Horizontal					
3	WSC036H	960	0.02	0.03	0.03	0.05	0.01	0.09	0.03	0.05	0.01	0.01	0.02	0.02	—
3	WSC036H	1200	0.03	0.05	0.04	0.07	0.02	0.13	0.05	0.07	0.01	0.02	0.03	0.03	—
3	WSC036H	1440	0.03	0.06	0.04	0.10	0.03	0.19	0.07	0.10	0.01	0.03	0.04	0.04	—
4	WSC048H	1280	0.03	0.06	0.04	0.10	0.03	0.15	0.05	0.09	0.01	0.02	0.03	0.03	—
4	WSC048H	1600	0.04	0.07	0.07	0.13	0.04	0.24	0.08	0.13	0.02	0.04	0.05	0.05	—
4	WSC048H	1920	0.06	0.10	0.08	0.17	0.06	0.34	0.11	0.17	0.02	0.05	0.06	0.08	—
5	WSC060H	1600	0.03	0.06	0.05	0.09	0.01	0.10	0.05	0.05	0.01	0.01	0.01	0.02	—
5	WSC060H	2000	0.05	0.08	0.07	0.11	0.01	0.16	0.08	0.07	0.02	0.02	0.01	0.03	—
5	WSC060H	2400	0.07	0.10	0.10	0.12	0.03	0.23	0.12	0.09	0.03	0.03	0.02	0.04	—
7.5	WSC092H	2400	0.04	0.06	0.12	0.11	0.02	0.23	0.12	0.08	0.02	—	0.02	0.02	—
7.5	WSC092H	3000	0.06	0.09	0.13	0.14	0.05	0.37	0.19	0.12	0.05	—	0.03	0.03	—
7.5	WSC092H	3600	0.09	0.13	0.15	0.21	0.07	0.54	0.27	0.25	0.08	—	0.04	0.05	—
8.5	WSC102H	2720	0.05	0.08	0.13	0.12	0.03	0.30	0.16	0.09	0.04	—	0.02	0.03	—
8.5	WSC102H	3400	0.08	0.11	0.14	0.19	0.06	0.48	0.24	0.18	0.06	—	0.03	0.04	—
8.5	WSC102H	4080	0.12	0.16	0.16	0.30	0.07	0.71	0.35	0.31	0.09	—	0.05	0.06	—
10	WSC120H	3200	0.07	0.10	0.14	0.17	0.05	0.42	0.22	0.14	0.05	—	0.02	0.03	0.05
10	WSC120H	4000	0.11	0.15	0.16	0.26	0.07	0.68	0.34	0.30	0.08	—	0.02	0.03	0.05
10	WSC120H	4800	0.16	0.20	0.18	0.34	0.09	0.99	0.48	0.35	0.10	—	0.03	0.04	0.06
3	D/WHC036H	960	0.02	0.03	0.03	0.05	0.01	0.09	0.03	0.05	0.01	0.01	0.02	0.02	—
3	D/WHC036H	1200	0.03	0.05	0.04	0.07	0.02	0.13	0.05	0.07	0.01	0.02	0.03	0.03	—
3	D/WHC036H	1440	0.03	0.06	0.04	0.10	0.03	0.19	0.07	0.10	0.01	0.03	0.04	0.04	—
4	D/WHC048H	1280	0.03	0.06	0.04	0.10	0.03	0.07	0.03	0.09	0.01	0.02	0.03	0.03	—

**Table 83. Static pressure drop through accessories (inches water column) (continued)**

Tons	Unit Model Number	cfm	Standard Filters <sup>(a)</sup>	2" MERV 8 Filter	2" MERV 13 Filter	Economizer with OA/RA Dampers <sup>(b)</sup>						Electric Heater Accessory (kW) <sup>(c),(d)</sup>			
						100% OA	100% RA	100% OA	100% RA	100% OA	100% RA	5-6	9-18	23-36	54
						Downflow		Low Leak <sup>(e)</sup>		Horizontal					
4	D/WHC048H	1600	0.04	0.07	0.07	0.13	0.04	0.10	0.05	0.13	0.02	0.04	0.05	0.05	—
4	D/WHC048H	1920	0.06	0.10	0.08	0.17	0.06	0.15	0.08	0.17	0.02	0.05	0.06	0.08	—
5	D/WHC060H	1600	0.03	0.06	0.05	0.09	0.01	0.10	0.05	0.05	0.01	0.01	0.01	0.02	—
5	D/WHC060H	2000	0.05	0.08	0.07	0.11	0.01	0.16	0.08	0.07	0.02	0.02	0.01	0.03	—
5	D/WHC060H	2400	0.07	0.10	0.10	0.12	0.03	0.23	0.12	0.09	0.03	0.03	0.02	0.04	—
6	W/DHC074	1920	0.03	0.04	0.10	0.09	0.01	0.15	0.08	0.06	0.01	—	0.01	0.01	—
6	W/DHC074	2400	0.04	0.06	0.12	0.11	0.02	0.23	0.12	0.08	0.02	—	0.01	0.01	—
6	W/DHC074	2880	0.06	0.08	0.13	0.13	0.04	0.34	0.18	0.11	0.04	—	0.01	0.02	—
7.5	W/DHC092	1500	0.02	0.03	0.08	0.07	0.01	0.09	0.05	0.04	0.01	—	—	—	—
7.5	W/DHC092	2400	0.04	0.06	0.12	0.11	0.02	0.23	0.12	0.08	0.02	—	0.01	0.01	—
7.5	W/DHC092	3000	0.06	0.09	0.13	0.14	0.05	0.37	0.19	0.12	0.05	—	0.01	0.02	—
7.5	W/DHC092	3600	0.09	0.13	0.15	0.21	0.07	0.54	0.27	0.25	0.08	—	0.02	0.03	—
8.5	W/DHC102	1700	0.02	0.05	0.11	0.07	0.01	0.11	0.06	0.05	0.02	—	—	—	—
8.5	W/DHC102	2720	0.05	0.08	0.13	0.12	0.03	0.30	0.16	0.09	0.04	—	0.01	0.02	—
8.5	W/DHC102	3400	0.08	0.11	0.14	0.19	0.06	0.48	0.24	0.18	0.06	—	0.02	0.02	—
8.5	W/DHC102	4080	0.12	0.16	0.16	0.30	0.07	0.71	0.35	0.31	0.09	—	0.03	0.03	—
10	W/DHC120	2000	0.03	0.06	0.11	0.08	0.03	0.16	0.08	0.07	0.02	—	—	—	—
10	W/DHC120	3200	0.07	0.10	0.14	0.17	0.05	0.42	0.22	0.14	0.05	—	0.02	0.03	0.05
10	W/DHC120	4000	0.11	0.15	0.16	0.26	0.07	0.68	0.34	0.30	0.08	—	0.02	0.03	0.05
10	W/DHC120	4800	0.16	0.20	0.18	0.34	0.09	0.99	0.48	0.35	0.10	—	0.03	0.04	0.06

(a) Tested with standard filters. Difference in pressure drop should be considered when utilizing optional 2" MERV 8 and MERV 13 filters.

(b) OA = Outside Air and RA = Return Air.

(c) Nominal kW ratings at 240, 480, 600 volts.

(d) Electric heaters restricted on applications below 320 cfm/ton.

(e) Low Leak - Downflow only.



# Heating Performance Data

**Table 84. 3 tons three phase heating capacities (net) WSC036H3,4,W at 1200 cfm**

Outdoor Temp (°F)	Integrated Heating Capacity (Btuh/1000) at Indicated Indoor Dry Bulb Temp <sup>(a)</sup> (°F)				Total Power in Kilowatts at Indicated Indoor Dry Bulb Temp (°F)			
	60	70	75	80	60	70	75	80
-8	12.7	12.1	11.7	11.4	2.4	2.6	2.8	2.9
-3	14.5	13.8	13.5	13.1	2.4	2.7	2.8	3.0
2	16.5	15.7	15.3	15.0	2.5	2.7	2.9	3.0
7	18.5	17.7	17.3	16.9	2.5	2.8	2.9	3.1
12	20.7	19.8	19.4	18.9	2.5	2.8	3.0	3.1
17	22.9	22.0	21.5	21.1	2.6	2.9	3.0	3.1
22	25.3	24.3	23.8	23.3	2.6	2.9	3.0	3.2
27	27.6	26.6	26.0	25.5	2.7	2.9	3.1	3.2
32	30.1	28.9	28.3	27.8	2.7	3.0	3.1	3.3
37	32.5	31.3	30.7	30.1	2.7	3.0	3.2	3.3
42	35.0	33.7	33.0	32.4	2.8	3.0	3.2	3.3
47	37.4	36.0	35.3	34.6	2.8	3.1	3.2	3.4
52	39.8	38.3	37.5	36.8	2.8	3.1	3.3	3.4
57	42.1	40.5	39.7	38.8	2.9	3.1	3.3	3.4
62	44.2	42.5	41.6	40.7	2.9	3.2	3.3	3.5
67	45.9	43.9	43.1	42.1	2.9	3.2	3.3	3.5
72	47.4	45.1	46.1	42.4	2.9	3.2	3.4	3.5

**Note:** Net heating capacity and power input includes indoor fan heat at AHRI esp. To obtain net heating at other conditions, subtract fan heat at this condition and add fan heat at new condition.

(a) Integrated heating capacities and powers include the effects of defrost in the frost region. All heating capacities and power (kw) are at 70% OD relative humidity and demand defrost cycle.



**Table 85. 4 tons three phase heating capacities (net) WSC048H3,4,W at 1600 cfm**

Outdoor Temp (°F)	Integrated Heating Capacity (Btuh/1000) at Indicated Indoor Dry Bulb Temp <sup>(a)</sup> (°F)				Total Power in Kilowatts at Indicated Indoor Dry Bulb Temp (°F)			
	60	70	75	80	60	70	75	80
-8	15.8	15.4	15.0	14.6	3.2	3.4	3.6	3.8
-3	18.6	17.8	17.4	17.0	3.1	3.4	3.6	3.8
2	21.2	20.4	20.0	19.6	3.2	3.5	3.7	3.9
7	23.8	23.0	22.4	22.4	3.2	3.6	3.8	4.0
12	26.6	25.8	25.3	24.9	3.3	3.6	3.8	4.0
17	29.4	28.6	28.1	27.7	3.3	3.7	3.9	4.1
22	32.4	31.5	31.0	30.5	3.4	3.7	3.9	4.1
27	35.4	34.4	33.9	33.4	3.4	3.8	4.0	4.2
32	38.5	37.5	36.9	36.4	3.5	3.8	4.0	4.2
37	41.6	40.5	40.0	39.4	3.5	3.9	4.1	4.3
42	44.8	43.7	43.1	42.5	3.5	3.9	4.1	4.4
47	48.1	46.8	46.2	45.6	3.6	4.0	4.2	4.4
52	51.3	50.0	49.3	48.7	3.7	4.0	4.2	4.5
57	54.6	53.1	52.4	51.7	3.7	4.1	4.3	4.5
62	58.0	56.3	55.6	54.6	3.8	4.2	4.4	4.6
67	61.4	59.6	58.7	57.8	3.8	4.2	4.4	4.6
72	64.6	62.0	61.6	60.6	3.9	4.2	4.4	4.7

**Note:** Net heating capacity and power input includes indoor fan heat at AHR! esp. To obtain net heating at other conditions, subtract fan heat at this condition and add fan heat at new condition.

(a) Integrated heating capacities and powers include the effects of defrost in the frost region. All heating capacities and power (kw) are at 70% OD relative humidity and demand defrost cycle.



## Heating Performance Data

**Table 86. 5 tons three phase heating capacities (net) WSC060H3,4,W at 2000 cfm**

Outdoor Temp (°F)	Integrated Heating Capacity (Btuh/1000) at Indicated Indoor Dry Bulb Temp <sup>(a)</sup> (°F)				Total Power in Kilowatts at Indicated Indoor Dry Bulb Temp (°F)			
	60	70	75	80	60	70	75	80
-8	18.2	17.2	16.8	16.3	3.7	4.1	4.3	4.5
-3	21.6	20.5	20.0	19.6	3.8	4.2	4.4	4.6
2	25.0	24.0	23.5	23.0	3.8	4.2	4.5	4.7
7	28.6	27.5	26.9	26.2	3.9	4.3	4.6	4.8
12	32.4	31.2	30.6	30.1	4.0	4.4	4.6	4.9
17	36.2	35.0	34.4	33.8	4.0	4.5	4.7	5.0
22	40.1	38.8	38.2	37.6	4.1	4.6	4.8	5.1
27	44.1	42.7	42.1	41.4	4.2	4.6	4.9	5.1
32	47.9	46.7	46.0	45.3	4.2	4.7	4.9	5.2
37	52.0	50.4	50.0	49.2	4.3	4.8	5.0	5.3
42	56.1	54.4	54.0	53.2	4.4	4.8	5.1	5.4
47	60.5	59.0	57.8	56.9	4.5	4.9	5.2	5.5
52	64.8	62.9	62.0	61.1	4.6	5.0	5.3	5.6
57	69.2	67.2	66.2	65.2	4.6	5.1	5.4	5.6
62	73.5	71.3	70.2	69.2	4.7	5.2	5.5	5.7
67	77.7	75.3	74.2	73.0	4.8	5.3	5.6	5.8
72	81.6	79.1	77.9	76.6	4.9	5.4	5.7	5.9

**Note:** Net heating capacity and power input includes indoor fan heat at AHRl esp. To obtain net heating at other conditions, subtract fan heat at this condition and add fan heat at new condition.

(a) Integrated heating capacities and powers include the effects of defrost in the frost region. All heating capacities and power (kw) are at 70% OD relative humidity and demand defrost cycle.

## Heating Performance Data

**Table 87. 7.5 tons three phase heating capacities (net) WSC092H3,4,W at 3000 cfm**

Outdoor Temp (°F)	Integrated Heating Capacity (MBh) at Indicated Indoor Dry Bulb Temp <sup>(a)</sup> (°F)				Total Power in Kilowatts at Indicated Indoor Dry Bulb Temp (°F)			
	60	70	75	80	60	70	75	80
-8	32.0	31.3	31.1	31.0	5.8	6.3	6.7	7.0
-3	36.4	35.7	35.5	35.3	5.9	6.5	6.8	7.2
2	40.9	40.3	40.0	39.8	6.0	6.6	6.9	7.3
7	45.8	44.8	44.4	44.2	6.1	6.7	7.0	7.4
12	50.4	49.8	49.5	49.1	6.2	6.8	7.2	7.5
17	55.5	54.5	54.0	53.7	6.3	6.9	7.3	7.7
22	60.8	59.6	59.1	58.7	6.4	7.0	7.4	7.8
27	66.4	65.0	64.4	63.8	6.5	7.1	7.5	7.9
32	72.1	70.6	69.9	69.2	6.6	7.3	7.6	8.0
37	77.8	76.1	75.3	74.5	6.7	7.4	7.7	8.1
42	83.5	81.7	80.8	79.9	6.8	7.5	7.8	8.2
47	89.5	87.5	86.5	85.6	6.9	7.6	7.9	8.3
52	95.7	93.5	92.4	91.3	7.0	7.7	8.1	8.4
57	101.9	99.5	98.2	97.0	7.1	7.8	8.2	8.6
62	108.1	105.3	103.9	102.6	7.3	7.9	8.3	8.7
67	114.0	110.9	109.4	107.9	7.4	8.1	8.4	8.8
72	119.9	116.2	114.4	112.7	7.5	8.2	8.5	8.9

**Note:** Net heating capacity and power input includes indoor fan heat at AHRI esp. To obtain net heating at other conditions, subtract fan heat at this condition and add fan heat at new condition.

(a) Integrated heating capacities and powers include the effects of defrost in the frost region. All heating capacities and power (kw) are at 70% OD relative humidity and demand defrost cycle.



## Heating Performance Data

**Table 88. 8.5 tons three phase high stage heating capacities (net) WSC102H3,4,W at 3400 cfm**

Outdoor Temp (°F)	Integrated Heating Capacity (Btuh/1000) at Indicated Indoor Dry Bulb Temp <sup>(a)</sup> (°F)				Total Power in Kilowatts at Indicated Indoor Dry Bulb Temp (°F)			
	60	70	75	80	60	70	75	80
-8	34.2	33.6	33.2	32.6	6.1	6.7	7.0	7.3
-3	38.5	37.8	37.7	37.0	6.2	6.8	7.1	7.5
2	43.0	42.3	41.9	41.5	6.3	6.9	7.3	7.6
7	48.2	47.4	46.6	46.1	6.4	7.1	7.4	7.7
12	52.9	51.9	51.5	51.0	6.5	7.2	7.5	7.9
17	58.0	57.0	56.5	56.0	6.6	7.3	7.6	8.0
22	63.5	62.4	61.8	61.2	6.7	7.4	7.7	8.1
27	69.2	67.9	67.2	66.7	6.8	7.5	7.8	8.2
32	75.1	73.7	73.0	72.3	6.9	7.6	8.0	8.3
37	81.2	79.5	78.7	77.9	7.0	7.7	8.1	8.4
42	87.2	85.5	84.6	83.7	7.2	7.8	8.2	8.6
47	93.6	91.7	90.7	89.7	7.3	7.9	8.3	8.7
52	100.4	98.2	97.1	96.1	7.4	8.1	8.4	8.8
57	107.4	105.0	103.8	102.6	7.5	8.2	8.6	8.9
62	114.7	111.9	110.6	109.3	7.7	8.3	8.7	9.1
67	122.0	119.0	117.5	116.0	7.8	8.5	8.9	9.2
72	129.4	126.0	124.3	122.7	8.0	8.6	9.0	9.4

**Note:** Net heating capacity and power input includes indoor fan heat at AHRI esp. To obtain net heating at other conditions, subtract fan heat at this condition and add fan heat at new condition.

(a) Integrated heating capacities and powers include the effects of defrost in the frost region. All heating capacities and power (kw) are at 70% OD relative humidity and demand defrost cycle.

## Heating Performance Data

**Table 89. 10 tons three phase heating capacities (net) WSC120H3,4,W at 4000 cfm**

Outdoor Temp (°F)	Integrated Heating Capacity (Btuh/1000) at Indicated Indoor Dry Bulb Temp <sup>(a)</sup> (°F)				Total Power in Kilowatts at Indicated Indoor Dry Bulb Temp (°F)			
	60	70	75	80	60	70	75	80
-8	35.0	32.5	31.2	30.0	7.4	8.1	8.6	9.0
-3	40.4	38.1	37.0	35.8	7.4	8.2	8.6	9.1
2	46.2	43.9	42.7	41.6	7.5	8.3	8.7	9.2
7	52.5	50.4	49.2	48.1	7.6	8.3	8.8	9.2
12	58.3	56.2	55.0	53.9	7.7	8.4	8.9	9.3
17	64.7	62.6	61.5	60.3	7.7	8.5	8.9	9.4
22	71.3	69.3	68.1	66.9	7.8	8.6	9.0	9.5
27	78.1	76.2	75.0	73.8	7.9	8.7	9.1	9.6
32	85.3	83.4	82.2	80.9	8.0	8.8	9.2	9.7
37	92.5	90.5	89.3	87.9	8.1	8.9	9.3	9.8
42	99.8	97.8	96.5	95.1	8.2	9.0	9.4	9.9
47	107.4	105.4	104.0	102.5	8.3	9.1	9.5	10.0
52	115.3	113.3	111.8	110.3	8.5	9.3	9.7	10.1
57	123.6	121.4	119.9	118.2	8.6	9.4	9.8	10.3
62	132.0	129.6	128.0	126.2	8.8	9.6	10.0	10.4
67	140.4	137.8	136.0	134.0	8.9	9.7	10.1	10.6
72	148.7	145.6	143.7	141.5	9.1	9.9	10.3	10.7

**Note:** Net heating capacity and power input includes indoor fan heat at AHRI esp. To obtain net heating at other conditions, subtract fan heat at this condition and add fan heat at new condition.

(a) Integrated heating capacities and powers include the effects of defrost in the frost region. All heating capacities and power (kw) are at 70% OD relative humidity and demand defrost cycle.



## Heating Performance Data

**Table 90. 3 tons three phase high stage heating capacities (net) W/DHC036H3,H4,HW at 1200 cfm**

Outdoor Temp (°F)	Integrated Heating Capacity (Btuh/1000) at Indicated Indoor Dry Bulb Temp <sup>(a)</sup> (°F)				Total Power in Kilowatts at Indicated Indoor Dry Bulb Temp (°F)			
	60	70	75	80	60	70	75	80
-8	8.0	7.2	6.7	6.3	1.9	2.1	2.2	2.4
-3	10.0	9.1	8.6	8.1	2.0	2.2	2.3	2.4
2	12.0	11.6	10.5	10.0	2.0	2.3	2.4	2.5
7	14.1	13.1	12.6	12.0	2.1	2.3	2.4	2.5
12	16.2	15.2	14.7	14.1	2.1	2.4	2.5	2.6
17	18.5	17.4	16.8	16.3	2.2	2.4	2.5	2.6
22	20.8	19.7	19.1	18.5	2.2	2.4	2.6	2.7
27	23.2	22.0	21.4	20.8	2.2	2.5	2.6	2.7
32	25.4	24.3	23.7	23.1	2.3	2.5	2.6	2.8
37	28.1	26.8	26.1	25.4	2.3	2.5	2.7	2.8
42	30.7	29.3	28.6	27.9	2.3	2.6	2.7	2.8
47	33.4	32.2	31.3	30.5	2.4	2.6	2.7	2.9
52	36.3	34.8	34.0	33.2	2.4	2.7	2.8	2.9
57	38.5	37.0	36.3	35.5	2.5	2.7	2.8	3.0
62	41.1	39.6	38.8	38.0	2.5	2.7	2.9	3.0
67	43.7	42.1	41.3	40.5	2.5	2.8	2.9	3.0
72	46.3	44.6	43.8	43.0	2.6	2.8	3.0	3.1

**Note:** Net heating capacity and power input includes indoor fan heat at AHRI esp. To obtain net heating at other conditions, subtract fan heat at this condition and add fan heat at new condition.

(a) Integrated heating capacities and powers include the effects of defrost in the frost region. All heating capacities and power (kw) are at 70% OD relative humidity and demand defrost cycle.

**Table 91. 3 tons three phase low stage heating capacities (net) W/DHC036H3,H4,HW at 840 cfm**

Outdoor Temp (°F)	Integrated Heating Capacity (Btuh/1000) at Indicated Indoor Dry Bulb Temp <sup>(a)</sup> (°F)				Total Power in Kilowatts at Indicated Indoor Dry Bulb Temp (°F)			
	60	70	75	80	60	70	75	80
22	13.5	12.4	11.9	11.3	1.72	1.88	1.97	2.06
27	15.3	14.3	13.7	13.2	1.73	1.89	1.98	2.07
32	17.2	16.1	15.6	15.0	1.73	1.90	1.99	2.08
37	19.1	18.0	17.5	16.9	1.74	1.91	2.00	2.09
42	21.1	20.0	19.4	18.8	1.75	1.92	2.00	2.10
47	22.9	21.9	21.3	20.7	1.75	1.92	2.01	2.11
52	25.0	23.8	23.2	22.6	1.76	1.93	2.02	2.11
57	27.0	25.7	25.1	24.4	1.76	1.93	2.02	2.12
62	28.9	27.6	27.0	26.3	1.76	1.93	2.03	2.12
67	30.8	29.4	28.7	27.9	1.76	1.94	2.03	2.13
72	32.8	31.2	30.5	29.7	1.76	1.93	2.03	2.13

**Note:** Net heating capacity and power input includes indoor fan heat at AHRI esp. To obtain net heating at other conditions, subtract fan heat at this condition and add fan heat at new condition.

(a) Integrated heating capacities and powers include the effects of defrost in the frost region. All heating capacities and power (kw) are at 70% OD relative humidity and demand defrost cycle.

**Table 92. 4 tons three phase high stage heating capacities (net) W/DHC048H3,H4,HW at 1600 cfm**

Outdoor Temp (°F)	Instantaneous Heating Capacity (Btuh/1000) at Indicated Indoor Dry Bulb Temp (°F)				Total Power in Kilowatts at Indicated Indoor Dry Bulb Temp (°F)			
	60	70	75	80	60	70	75	80
-8	10.51	9.90	9.68	9.22	2.76	3.02	3.17	3.33
-3	13.12	12.67	12.22	11.86	2.80	3.07	3.22	3.38
2	16.15	15.40	15.02	14.62	2.83	3.11	3.27	3.43
7	19.14	18.13	17.84	17.43	2.88	3.17	3.32	3.49
12	22.20	21.29	20.77	20.32	2.92	3.21	3.37	3.54
17	25.33	24.33	23.84	23.36	2.97	3.26	3.42	3.60
22	28.53	27.46	26.93	26.41	3.01	3.31	3.48	3.65
27	31.78	30.64	30.07	29.52	3.06	3.36	3.53	3.71
32	35.07	33.86	32.99	32.66	3.10	3.42	3.59	3.77
37	38.20	37.08	36.40	35.83	3.16	3.47	3.64	3.82
42	41.69	40.34	39.40	39.03	3.20	3.52	3.70	3.88
47	45.01	43.78	42.92	42.02	3.26	3.59	3.75	3.95
52	48.53	46.91	46.12	45.33	3.32	3.64	3.82	4.01
57	51.57	49.99	49.21	48.44	3.35	3.68	3.86	4.05
62	54.71	53.06	52.23	51.41	3.40	3.73	3.91	4.10
67	57.72	56.57	56.30	54.20	3.44	3.80	3.99	4.15
72	61.43	59.39	57.64	57.02	3.51	3.84	4.02	4.25

**Note:** Net heating capacity and power input includes indoor fan heat at AHRI esp. To obtain net heating at other conditions, subtract fan heat at this condition and add fan heat at new condition.

**Table 93. 4 tons three phase low stage heating capacities (net) W/DHC048H3,H4,HW at 1120 cfm**

Outdoor Temp (°F)	Instantaneous Heating Capacity (Btuh/1000) at Indicated Indoor Dry Bulb Temp (°F)				Total Power in Kilowatts at Indicated Indoor Dry Bulb Temp (°F)			
	60	70	75	80	60	70	75	80
22	18.20	17.05	16.45	15.82	2.24	2.51	2.65	2.80
27	20.73	19.57	18.97	18.34	2.26	2.53	2.68	2.83
32	23.30	22.13	21.52	20.90	2.27	2.55	2.70	2.85
37	25.90	24.72	24.10	23.47	2.28	2.57	2.72	2.88
42	28.53	27.32	26.69	26.05	2.30	2.58	2.74	2.90
47	31.14	29.89	29.25	28.60	2.31	2.60	2.76	2.92
52	33.70	32.40	31.75	31.08	2.32	2.61	2.77	2.93
57	36.18	34.82	34.14	33.45	2.32	2.62	2.78	2.94
62	38.27	37.12	36.40	35.68	2.33	2.62	2.78	2.94
67	40.75	39.20	38.42	37.67	2.31	2.60	2.76	2.93
72	42.51	41.00	40.18	39.36	2.29	2.58	2.73	2.90

**Note:** Net heating capacity and power input includes indoor fan heat at AHRI esp. To obtain net heating at other conditions, subtract fan heat at this condition and add fan heat at new condition.



## Heating Performance Data

**Table 94. 5 tons three phase high stage heating capacities (net) W/DHC060H3,H4,HW at 2000 cfm**

Outdoor Temp (°F)	Instantaneous Heating Capacity (Btuh/1000) at Indicated Indoor Dry Bulb Temp (°F)				Total Power in Kilowatts at Indicated Indoor Dry Bulb Temp (°F)			
	60	70	75	80	60	70	75	80
-8	17.63	16.83	16.42	15.98	3.37	3.69	3.88	4.07
-3	20.85	20.00	19.56	19.13	3.43	3.76	3.95	4.15
2	24.19	23.28	22.81	22.35	3.48	3.83	4.02	4.22
7	27.58	26.40	26.76	25.81	3.54	3.89	4.08	4.29
12	31.23	30.17	29.65	29.12	3.59	3.95	4.14	4.36
17	34.92	33.79	33.21	32.65	3.64	4.01	4.20	4.42
22	38.71	37.50	36.88	36.28	3.70	4.06	4.26	4.48
27	42.59	41.29	40.64	39.99	3.75	4.12	4.32	4.54
32	46.54	44.87	44.47	43.78	3.80	4.18	4.38	4.60
37	50.28	48.78	48.32	47.60	3.86	4.24	4.44	4.66
42	54.34	52.70	52.26	51.50	3.92	4.30	4.51	4.73
47	58.65	57.22	56.00	55.12	3.99	4.38	4.59	4.81
52	63.03	61.12	60.17	59.22	4.06	4.45	4.66	4.89
57	67.39	65.36	64.33	63.19	4.14	4.53	4.74	4.95
62	71.78	69.55	68.44	66.99	4.22	4.61	4.83	5.03
67	76.09	73.66	72.45	71.27	4.31	4.70	4.92	5.14
72	80.14	77.61	75.30	74.75	4.40	4.80	4.99	5.28

**Note:** Net heating capacity and power input includes indoor fan heat at AHRI esp. To obtain net heating at other conditions, subtract fan heat at this condition and add fan heat at new condition.

**Table 95. 5 tons three phase low stage heating capacities (net) W/DHC060H3,H4,HW at 1400 cfm**

Outdoor Temp (°F)	Instantaneous Heating Capacity (Btuh/1000) at Indicated Indoor Dry Bulb Temp (°F)				Total Power in Kilowatts at Indicated Indoor Dry Bulb Temp (°F)			
	60	70	75	80	60	70	75	80
22	24.25	23.31	22.79	22.25	2.88	3.21	3.39	3.57
27	27.16	26.16	25.62	25.06	2.90	3.23	3.41	3.60
32	30.12	29.06	28.49	27.91	2.91	3.24	3.43	3.62
37	33.10	31.97	31.38	30.77	2.92	3.26	3.44	3.64
42	36.14	34.94	34.31	33.67	2.94	3.28	3.46	3.65
47	39.17	37.89	37.23	36.55	2.95	3.29	3.48	3.67
52	41.92	40.47	40.09	39.14	2.97	3.31	3.49	3.68
57	45.15	43.67	42.93	42.17	2.97	3.31	3.49	3.68
62	48.11	46.42	45.57	44.87	2.98	3.32	3.50	3.68
67	51.09	49.26	48.34	47.41	2.97	3.30	3.48	3.67
72	53.97	51.92	50.93	49.92	2.95	3.28	3.46	3.64

**Note:** Net heating capacity and power input includes indoor fan heat at AHRI esp. To obtain net heating at other conditions, subtract fan heat at this condition and add fan heat at new condition.



## Heating Performance Data

**Table 96. 6 tons three phase low stage heating capacities (net) W/DHC074H3,4,W at 1680 cfm**

Outdoor Temp (°F)	Integrated Heating Capacity (Mbh) at Indicated Indoor Dry Bulb Temp (°F)				Total Power in Kilowatts at Indicated Indoor Dry Bulb Temp (°F)			
	60	70	75	80	60	70	75	80
22	25.2	24.2	23.7	23.2	2.91	3.18	3.33	3.48
27	28.1	27.0	26.4	25.9	2.92	3.20	3.34	3.50
32	31.0	29.8	29.2	28.7	2.93	3.21	3.36	3.51
37	33.7	32.7	32.1	31.4	2.95	3.22	3.36	3.52
42	36.6	35.4	34.9	34.2	2.96	3.23	3.37	3.53
47	39.7	38.3	37.5	36.8	2.95	3.23	3.37	3.53
52	42.3	40.7	39.9	39.1	2.95	3.22	3.37	3.52
57	44.6	42.9	42.0	41.2	2.96	3.22	3.36	3.51
62	47.6	45.8	44.8	43.9	2.98	3.25	3.39	3.54
67	50.6	48.6	47.5	46.4	3.00	3.27	3.43	3.58
72	53.4	51.3	50.2	49.1	3.02	3.29	3.43	3.60

**Note:** Net heating capacity and power input includes indoor fan heat at AHRI esp. To obtain net heating at other conditions, subtract fan heat at this condition and add fan heat at new condition.

**Table 97. 6 tons three phase high stage heating capacities (net) W/DHC074H3,4,W at 2400 cfm**

Outdoor Temp (°F)	Integrated Heating Capacity (Mbh) at Indicated Indoor Dry Bulb Temp (°F)				Total Power in Kilowatts at Indicated Indoor Dry Bulb Temp (°F)			
	60	70	75	80	60	70	75	80
-8	23.0	22.4	22.1	21.9	4.78	5.33	5.62	5.93
-3	27.1	26.4	26.1	25.8	4.89	5.45	5.74	6.05
2	31.4	30.7	30.3	30.0	5.00	5.55	5.85	6.16
7	35.6	34.8	34.6	34.2	5.10	5.66	5.95	6.27
12	40.5	39.6	39.1	38.7	5.18	5.74	6.04	6.36
17	44.9	43.9	43.5	43.3	5.27	5.84	6.14	6.45
22	49.9	48.7	48.2	47.7	5.36	5.92	6.22	6.54
27	55.0	53.7	53.1	52.5	5.43	6.00	6.30	6.62
32	59.8	58.8	58.1	57.5	5.49	6.07	6.38	6.70
37	65.6	64.0	63.3	62.5	5.57	6.14	6.45	6.77
42	70.9	69.2	68.4	67.5	5.63	6.20	6.51	6.83
47	76.5	74.6	73.6	72.7	5.70	6.27	6.58	6.91
52	82.1	80.0	78.9	77.9	5.77	6.34	6.65	6.97
57	87.6	85.3	84.1	83.0	5.84	6.41	6.71	7.03
62	93.0	90.4	89.1	87.8	5.90	6.46	6.77	7.09
67	98.0	95.1	93.6	92.2	5.96	6.51	6.81	7.13
72	102.7	99.5	97.8	96.2	6.02	6.58	6.87	7.18

**Note:** Net heating capacity and power input includes indoor fan heat at AHRI esp. To obtain net heating at other conditions, subtract fan heat at this condition and add fan heat at new condition.



## Heating Performance Data

**Table 98. 7.5 tons three phase low stage heating capacities (net) W/DHC092H3,4,W at 2100 cfm**

Outdoor Temp (°F)	Integrated Heating Capacity (Mbh) at Indicated Indoor Dry Bulb Temp (°F)				Total Power in Kilowatts at Indicated Indoor Dry Bulb Temp (°F)			
	60	70	75	80	60	70	75	80
22	31.5	29.9	29.1	28.3	3.40	3.73	3.91	4.10
27	35.1	33.4	32.6	31.7	3.43	3.77	3.95	4.13
32	38.7	37.0	36.1	35.2	3.46	3.80	3.98	4.17
37	42.3	40.5	39.6	38.7	3.49	3.83	4.01	4.20
42	46.0	44.2	43.2	42.3	3.52	3.87	4.05	4.24
47	49.8	47.8	46.8	45.8	3.55	3.90	4.08	4.27
52	53.5	51.4	50.4	49.3	3.58	3.93	4.11	4.30
57	57.1	54.9	53.8	52.7	3.61	3.96	4.14	4.33
62	60.9	58.5	57.3	56.0	3.65	4.00	4.18	4.37
67	64.4	61.7	60.3	59.0	3.69	4.04	4.22	4.41
72	67.3	64.3	62.7	61.2	3.70	4.05	4.23	4.42

**Note:** Net heating capacity and power input includes indoor fan heat at AHRI esp. To obtain net heating at other conditions, subtract fan heat at this condition and add fan heat at new condition.

**Table 99. 7.5 tons three phase high stage heating capacities (net) W/DHC092H3,4,W at 3000 cfm**

Outdoor Temp (°F)	Integrated Heating Capacity (Mbh) at Indicated Indoor Dry Bulb Temp (°F)				Total Power in Kilowatts at Indicated Indoor Dry Bulb Temp (°F)			
	60	70	75	80	60	70	75	80
-8	27.5	26.6	26.1	25.6	5.58	6.19	6.51	6.86
-3	32.4	31.4	30.9	30.3	5.67	6.28	6.62	6.97
2	37.3	36.3	35.8	35.2	5.76	6.38	6.72	7.08
7	42.6	41.3	40.7	40.1	5.85	6.48	6.83	7.19
12	47.7	46.4	46	45.4	5.95	6.58	6.93	7.30
17	53.2	51.8	51.1	50.4	6.04	6.68	7.03	7.41
22	58.8	57.3	56.6	55.8	6.13	6.78	7.14	7.51
27	64.7	63	62.2	61.4	6.22	6.88	7.24	7.62
32	70.2	68.9	68	67.1	6.30	6.98	7.34	7.73
37	76.6	74.7	73.7	72.7	6.40	7.07	7.44	7.83
42	82.7	80.6	79.5	78.4	6.49	7.17	7.54	7.93
47	88.9	86.6	85.4	84.3	6.59	7.28	7.65	8.04
52	95.2	92.7	91.4	90.2	6.69	7.38	7.75	8.14
57	101.4	98.7	97.4	96	6.79	7.48	7.85	8.24
62	107.7	104.7	103.1	101.6	6.89	7.58	7.95	8.34
67	114.1	110.6	108.9	107.2	7.01	7.69	8.06	8.44
72	120	116.3	114.4	112.4	7.12	7.80	8.17	8.56

**Note:** Net heating capacity and power input includes indoor fan heat at AHRI esp. To obtain net heating at other conditions, subtract fan heat at this condition and add fan heat at new condition.

## Heating Performance Data

**Table 100. 8.5 tons three phase low stage heating capacities (net) W/DHC102H3,4,W at 2380 cfm**

Outdoor Temp (°F)	Integrated Heating Capacity (Mbh) at Indicated Indoor Dry Bulb Temp (°F)				Total Power in Kilowatts at Indicated Indoor Dry Bulb Temp (°F)			
	60	70	75	80	60	70	75	80
22	31.6	29.8	28.8	27.8	3.12	3.43	3.60	3.77
27	35.2	33.3	32.3	31.3	3.14	3.46	3.62	3.79
32	38.8	36.8	35.8	34.8	3.16	3.48	3.65	3.82
37	42.4	40.4	39.5	38.3	3.18	3.50	3.67	3.84
42	46.3	44.2	43.2	42.0	3.21	3.52	3.69	3.87
47	50.2	48.0	47.0	45.7	3.23	3.55	3.72	3.90
52	54.3	51.9	50.7	49.4	3.25	3.58	3.75	3.92
57	58.4	56.0	54.7	53.4	3.27	3.59	3.77	3.95
62	62.5	59.9	58.6	57.3	3.29	3.62	3.79	3.97
67	66.5	64.2	62.7	61.2	3.31	3.66	3.83	4.01
72	71.3	68.3	66.8	65.2	3.35	3.68	3.86	4.04

**Note:** Net heating capacity and power input includes indoor fan heat at AHRI esp. To obtain net heating at other conditions, subtract fan heat at this condition and add fan heat at new condition.

**Table 101. 8.5 tons three phase high stage heating capacities (net) W/DHC102H3,4,W at 3400 cfm**

Outdoor Temp (°F)	Integrated Heating Capacity (Mbh) at Indicated Indoor Dry Bulb Temp (°F)				Total Power in Kilowatts at Indicated Indoor Dry Bulb Temp (°F)			
	60	70	75	80	60	70	75	80
-8	30.3	28.3	27.0	25.8	5.65	6.27	6.59	6.93
-3	35.2	33.1	31.9	30.8	5.77	6.40	6.73	7.07
2	40.2	38.1	37.0	35.7	5.89	6.52	6.86	7.21
7	45.7	43.6	42.5	41.2	5.99	6.63	6.98	7.33
12	51.0	48.8	47.7	46.4	6.10	6.75	7.10	7.46
17	56.7	54.5	53.3	52.1	6.21	6.86	7.21	7.58
22	62.7	60.4	59.2	57.9	6.31	6.97	7.33	7.70
27	68.9	66.5	65.3	64.0	6.41	7.08	7.44	7.82
32	74.6	72.9	71.6	70.2	6.49	7.19	7.55	7.93
37	81.9	79.2	77.9	76.5	6.60	7.29	7.66	8.04
42	88.5	85.7	84.3	82.8	6.70	7.39	7.76	8.15
47	95.4	92.4	90.9	89.4	6.80	7.50	7.87	8.27
52	102.6	99.5	97.9	96.2	6.91	7.61	7.99	8.39
57	109.9	106.5	104.8	103.1	7.02	7.73	8.11	8.51
62	117.3	113.7	111.9	110.0	7.13	7.84	8.23	8.63
67	124.7	120.8	118.8	116.9	7.25	7.96	8.34	8.75
72	131.9	127.9	125.7	123.6	7.36	8.08	8.46	8.87

**Note:** Net heating capacity and power input includes indoor fan heat at AHRI esp. To obtain net heating at other conditions, subtract fan heat at this condition and add fan heat at new condition.



## Heating Performance Data

**Table 102. 10 tons three phase low stage heating capacities (net) W/DHC120H3,4,W at 2800 cfm**

Outdoor Temp (°F)	Integrated Heating Capacity (Mbh) at Indicated Indoor Dry Bulb Temp (°F)				Total Power in Kilowatts at Indicated Indoor Dry Bulb Temp (°F)			
	60	70	75	80	60	70	75	80
22	40.5	39.1	38.4	37.6	3.72	4.08	4.27	4.48
27	44.4	42.9	42.1	41.3	3.74	4.11	4.30	4.51
32	48.4	46.8	45.9	45.1	3.77	4.14	4.34	4.55
37	52.4	50.7	49.8	48.9	3.80	4.17	4.37	4.59
42	56.4	54.8	53.8	52.9	3.84	4.21	4.41	4.63
47	60.6	58.8	57.9	56.9	3.88	4.25	4.45	4.67
52	64.8	63.0	61.9	60.9	3.92	4.29	4.50	4.72
57	69.3	67.1	66.0	64.8	3.96	4.34	4.55	4.76
62	73.5	71.1	69.9	68.7	4.01	4.39	4.60	4.82
67	77.6	75.1	73.8	72.5	4.06	4.45	4.65	4.87
72	82.0	79.1	77.6	76.1	4.15	4.53	4.74	4.95

**Note:** Net heating capacity and power input includes indoor fan heat at AHRI esp. To obtain net heating at other conditions, subtract fan heat at this condition and add fan heat at new condition.

**Table 103. 10 tons three phase high stage heating capacities (net) W/DHC120H3,4,W at 4000 cfm**

Outdoor Temp (°F)	Integrated Heating Capacity (Mbh) at Indicated Indoor Dry Bulb Temp (°F)				Total Power in Kilowatts at Indicated Indoor Dry Bulb Temp (°F)			
	60	70	75	80	60	70	75	80
-8	44.6	43.7	43.5	42.9	7.40	8.17	8.60	9.05
-3	50.6	49.3	49.2	48.6	7.50	8.30	8.73	9.20
2	56.0	55.0	54.5	54.0	7.60	8.42	8.87	9.34
7	62.6	61.6	61.0	59.9	7.69	8.53	9.00	9.49
12	68.4	67.2	66.7	66.1	7.80	8.66	9.13	9.63
17	75.1	73.8	73.1	72.5	7.90	8.77	9.25	9.76
22	82.0	80.6	79.9	79.2	8.00	8.89	9.38	9.90
27	89.3	87.7	86.9	86.1	8.11	9.01	9.51	10.03
32	96.8	95.0	94.2	93.3	8.22	9.13	9.64	10.17
37	104.2	102.3	101.3	100.4	8.33	9.26	9.76	10.30
42	111.8	109.7	108.6	107.6	8.44	9.38	9.89	10.43
47	119.7	117.4	116.2	115.1	8.56	9.52	10.03	10.58
52	127.9	125.3	124.1	122.8	8.70	9.66	10.18	10.74
57	136.3	133.4	132.0	130.6	8.85	9.82	10.34	10.89
62	144.8	141.5	139.9	138.4	9.01	9.98	10.50	11.05
67	153.2	149.5	147.7	145.9	9.18	10.14	10.66	11.21
72	161.0	157.1	155.1	153.1	9.34	10.31	10.83	11.37

**Note:** Net heating capacity and power input includes indoor fan heat at AHRI esp. To obtain net heating at other conditions, subtract fan heat at this condition and add fan heat at new condition.

**Table 104. Auxiliary electric heat capacity<sup>(a)</sup>**

Tons	Unit Model Number	Total <sup>(b)</sup>		No. of Stages	Stage1		Stage 2	
		kW Input <sup>(c)</sup>	MBh Output		kW Input	MBh Output	kW Input	MBh Output
3	W*C036H3,4,W	6.00	20.48	1	6.00	20.48	—	—
3	W*C036H3,4,W	12.00	40.97	2	6.00	20.48	6.00	20.48
3	W*C036H3,4,W	17.40	59.40	2	8.70	29.70	8.70	29.70
4	W*C048H3,4,W	6.00	20.48	1	6.00	20.48	—	—
4	W*C048H3,4,W	12.00	40.97	2	6.00	20.48	6.00	20.48
4	W*C048H3,4,W	17.40	59.40	2	8.70	29.70	8.70	29.70
5	W*C060H3,4,W	6.00	20.48	1	6.00	20.48	—	—
5	W*C060H3,4,W	12.00	40.97	2	6.00	20.48	6.00	20.48
5	W*C060H3,4,W	17.40	59.40	2	8.70	29.70	8.70	29.70
5	W*C060H3,4,W	23.00	78.52	2	8.70	29.70	14.30	48.82
7.5	WSC092H3,4/WHC092H3,4,W	9	30.73	1	9	30.73	—	—
7.5	WSC092H3,4/WHC092H3,4,W	18	61.45	1	18	61.45	—	—
7.5	WSC092H3,4/WHC092H3,4,W	27	92.18	2	18	61.45	9	30.73
7.5	WSC092H3,4/WHC092H3,4,W	36	122.9	2	18	61.45	18	61.45
8.5	WSC102H3,4/WHC102H3,4	9	30.73	1	9	30.73	—	—
8.5	WSC102H3,4,W/WHC102H3,4,W	18	61.45	1	18	61.45	—	—
8.5	WSC102H3,4,W/WHC102H3,4,W	27	92.18	2	18	61.45	9	30.73
8.5	WSC102H3,4,W/WHC102H3,4,W	36	122.9	2	18	61.45	18	61.45
10	WSC120H3,4,W/WHC120H3,4,W	18	61.45	1	18	61.45	—	—
10	WSC120H3,4,W/WHC120H3,4,W	27	92.18	2	18	61.45	9	30.73
10	WSC120H3,4,W/WHC120H3,4,W	36	122.9	2	18	61.45	18	61.45
10	WSC120H3,4,W/WHC120H3,4,W	54	184.36	2	36	122.9	18	61.45

(a) 600V is not available on high efficiency units.

(b) Heaters are rated at 240V, 380V, 480V and 600V. For other than rated voltage, CAP= (voltage/rated voltage)<sup>2</sup> x rated cap.

(c) All input/output does not include indoor fan power or heat.

**Table 105. Auxiliary gas fired heating capacities - high efficiency**

Tons	Unit Model Number	Heating Input MBh <sup>(a)</sup>	Heating Output MBh	Air Temp Rise, °F
3	DHC036H(3,4,W)*(L,X)	60/42	48.6/34	20-50
3	DHC036H(3,4,W)*(M,Y)	80/56	64.8/45.3	35-65
3	DHC036H(3,4,W)*(H,Z)	100/70	81/56.7	45-75
4	DHC048H(3,4,W)*(L,X)	60/42	48.6/34	15-45
4	DHC048H(3,4,W)*(M,Y)	100/70	81/56.7	30-60
4	DHC048H(3,4,W)*(H,Z)	130/91	105.3/73.7	45-75
5	DHC060H(3,4,W)*(L,X)	60/42	48.6/34	10-40
5	DHC060H(3,4,W)*(M,Y)	100/70	81/56.7	25-55
5	DHC060H(3,4,W)*(H,Z)	150/105	121.5/85	40-70
6	DHC074H(3,4,W)*(L,X)	80/80	64.8	15-45
6	DHC074H(3,4,W)*(M,Y)	120/120	97.2	20-50
6	DHC074H(3,4,W)*(H,Z)	150/105	121.5/85.05	25-55
7.5	DHC092H(3,4,W)*(L,X)	120/120	97.2	20-50
7.5	DHC092H(3,4,W)*(M,Y)	150/105	121.5/85.05	20-50



## Heating Performance Data

**Table 105. Auxiliary gas fired heating capacities - high efficiency (continued)**

Tons	Unit Model Number	Heating Input MBh <sup>(a)</sup>	Heating Output MBh	Air Temp Rise, °F
7.5	DHC092H(3,4,W)*(H,Z)	200/140	162/113.4	35-65
8.5	DHC102H(3,4,W)*(L,X)	120/120	97.2	20-50
8.5	DHC102H(3,4,W)*(M,Y)	150/105	121.5/85.05	20-50
8.5	DHC102H(3,4,W)*(H,Z)	200/140	162/113.4	35-65
10	DHC120H(3,4,W)*(L,X)	150/105	121.5/85.05	20-50
10	DHC120H(3,4,W)*(M,Y)	200/140	162/113.4	25-55
10	DHC120H(3,4,W)*(H,Z)	250/175	202.5/141.75	35-65

**Note:** Ratings shown are for elevations up to 2,000 ft. For higher elevations, reduce ratings at a rate of 4% per 1,000 ft. elevation.

(a) For two stage heaters (input or output), second stage is total heating capacity (Second Stage/First Stage).

**Table 106. Electric heater voltage correction factors (applicable to auxiliary heat capacity)**

Nominal Voltage	Distribution Voltage	Capacity Multiplier
240	208	0.751
240	230	0.918
240	240	1.000
480	440	0.840
480	460	0.918
480	480	1.000
600	540	0.810
600	575	0.918
600	600	1.000

**Table 107. 3 to 5 tons air temperature rise across electric heaters (°F)**

kW	Stages	3 Tons <sup>(a)</sup> 1200 cfm	4 Tons 1600 cfm	5 Tons <sup>(b)</sup> 2000 cfm
		Three Phase W*C036H3,4,W	Three Phase W*C048H3,4,W	Three Phase W*C060H3,4,W
6.00	1	18.5	10.5	11.4
12.00	2	36.2	22.3	21.5
17.40	2	48.2	33.0	30.0
17.60	2	—	—	—
23.0	2	—	—	38.8

**Notes:**

- For minimum design airflow, see airflow performance table for each unit.
- To calculate temp rise at different airflow, use the following formula: Temp. rise across electric heater = kWx3414/1.08xCFM.

(a) The minimum allowable airflow for a 3 ton with a 17.4 kW heater is 1080 cfm.

(b) The minimum allowable airflow for a 5 ton unit with a 23.0 kW heater is 1900 cfm.

**Table 108. 6 to 10 tons air temperature rise across electric heaters (°F)**

kW	Stages	6 Tons 2000 cfm	7.5 Tons 3000 cfm	8.5 Tons 3400 cfm	10 Tons 4000 cfm <sup>(a)</sup>
		WHC074H3,4,W	WSC092H3,4,W WHC092H3,4,W	WSC102H3,4,W WHC102H3,4,W	WSC120H3,4,W WHC120H3,4,W
9.0	1	14.2	9.5	9.5	—
18.0	1	28.5	19.0	19.0	14.2
27.0	2	42.7	28.5	28.5	21.3
36.0	2	56.9	37.9	37.9	28.5
54.0	2	—	—	—	42.7

**Notes:**

1. For minimum design airflow, see airflow performance table for each unit.
2. To calculate temp rise at different airflow, use the following formula: Temp. rise across electric heater = kWx3414/1.08xCFM.

(a) Minimum allowable airflow with a 54 kW heater for the WSC120H is 4000 cfm.



# Controls

## ReliaTel™

Zone sensors are the building occupant's comfort control devices. The following zone sensor options are available for units with ReliaTel™ control.

**Note:** Zone sensor required for units configured for single zone VAV indoor fan control to enable single zone VAV functionality.

## Economizer Controls

The standard equipment offering is a fixed dry bulb changeover control. In addition, there are two optional controls, enthalpy and differential enthalpy control.

### Enthalpy Control

Replaces the dry bulb control with a wet bulb changeover controller which has a fully adjustable setpoint. Enthalpy control offers a higher level of comfort control, along with energy savings potential, than the standard dry bulb control. This is due to the additional wet bulb sensing capability.

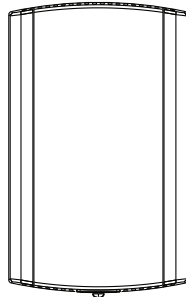
### Differential Enthalpy

Differential enthalpy replaces the standard dry bulb control with two enthalpy sensors that compare total heat content of the indoor air and outdoor air to determine the most efficient air source. This control option offers the highest level of comfort control, plus energy efficiency, available.

### Remote Potentiometer

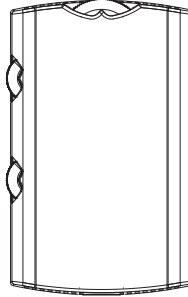
Minimum position setting of economizer can be remotely adjusted with this accessory.

**Remote Sensor**



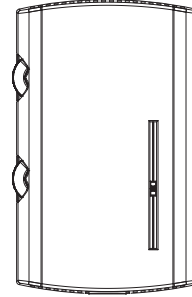
Sensor(s) available for all zone sensors to provide remote sensing capabilities.

**Manual Changeover**



Heat, Cool or Off System Switch. Fan Auto or Off Switch. One temperature setpoint lever.

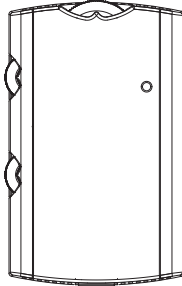
**Manual/Automatic Changeover**



Auto, Heat, Cool or Off System Switch. Fan Auto or Off Switch. Two temperature setpoint levers.

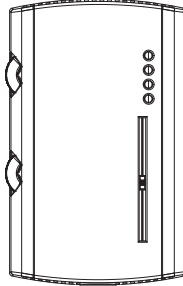


**Manual/Automatic Changeover - Status Indicator**



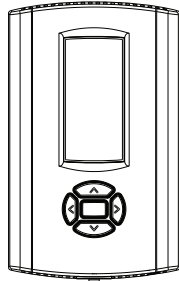
Auto, Heat, Cool or Off System Switch. Fan Auto or Off Switch. Two temperature setpoint levers. Includes a status indicator.

**Manual/Automatic Changeover**



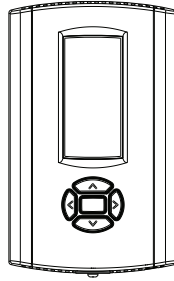
Auto, Heat, Cool or Off System Switch. Fan Auto or Off Switch. Two temperature setpoint levers. Status Indication LED lights, System On, Heat, Cool, or Service.

**Digital Display Programmable Thermostat (1H/1C)**



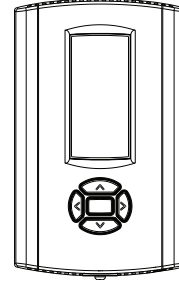
One heat/One Cool Auto changeover digital display thermostat.

**Digital Display Thermostat (3H/2C)**



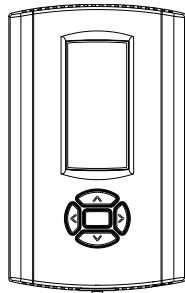
Three Heat, Two Cool Auto changeover digital display thermostat.

**Digital Display Programmable Thermostat (3H/2C)**



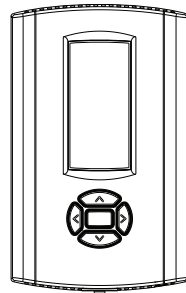
Three Heat/Two Cool Auto changeover digital display thermostat. 7-day programmable stat with night setback is available.

**Programmable Night Setback**



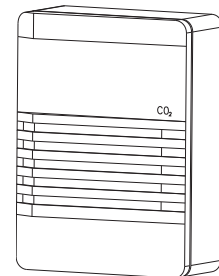
Auto or manual changeover with seven-day programming. Keyboard selection of Heat, Cool, Fan, Auto, or On. All programmable sensors have System On, Heat, Cool, Service LED/indicators as standard. Night Setback Sensors have one (1) Occupied, one (1) Un-occupied, and one (1) Override program per day.

**Wireless Zone Sensor**

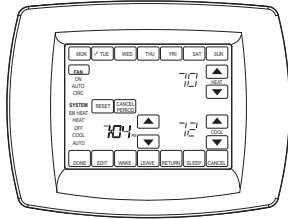


LCD display that provides heat, cool, auto or off. Includes two temperature setpoints and a lockable setting with °F or °C indicators.

**CO<sub>2</sub> Sensing**



The CO<sub>2</sub> sensor shall have the ability to monitor space occupancy levels within the building by measuring the parts per million of CO<sub>2</sub> (Carbon Dioxide) in the air. As the CO<sub>2</sub> levels increase, the outside air damper modulates to meet the CO<sub>2</sub> space ventilation requirements. The CO<sub>2</sub> accessory shall be available as field installed.

**Touchscreen Programmable Thermostat (2H/2C)**


Two Heat/Two Cool programmable thermostat with touch screen digital display. Menu-driven programming. Effortless set-up. Program each day separately with no need to copy multiple days. All programming can be done on one screen. Easy to read and use. Large, clear backlit digital display.

**Digital Display Programmable Thermostat with Built-In Relative Humidity Sensing (3H/2C)**


Three Heat, Two Cool digital display thermostat with built-in humidity control and display. This thermostat combines both humidity and dry bulb into one. Fully programmable with night setback.

## Differential Pressure Switches

This factory or field-installed option allows individual fan failure and dirty filter indication. The fan failure switch will disable all unit functions and “flash” the Service LED on the zone sensor. The dirty filter switch will light the Service LED on the zone sensor and will allow continued unit operation.

## RA Remote Sensor

Return air remote sensor which can be mounted in the return air duct to report return air temperature.

## Room Remote Sensor

Space remote sensor which can be mounted on the wall to report/control from a remote location in the space.

## Communication Interfaces

### BACnet® Communication Interface

This option shall be provided to allow the unit to communicate directly with a generic open protocol BACnet® MS/TP Network Building Automation System Controls.

### Trane® Air-Fi® Wireless Communication - Factory Installed

Air-Fi Wireless communication shall be factory installed and tested. Air-Fi Wireless conforms to ANSI/ASHRAE Standard 135-2016 (BACnet®/ZigBee®<sup>1</sup>).

### Trane® Communication Interface (TCI)

This factory or field-installed micro-processor interface allows the unit to communicate to Trane® Integrated Comfort™ system.

<sup>1</sup> ZigBee is a registered trademark of the ZigBee Alliance.

## **LonTalk® Communications Interface - Factory or Field Installed**

The LonTalk® communications interface allows the unit to communicate as a Tracer® LCI-V device or directly with a generic open protocol BACnet® MS/TP Network Building Automation System Controls.



# Electrical Data

**Table 109. Unit wiring - standard efficiency**

Tons	Unit Model Number	Voltage Range	Standard Indoor Fan Motor <sup>(a)</sup>		Oversized Indoor Fan Motor		Optional EBM Indoor Fan Motor	
			MCA	Max Fuse Size or Max Circuit Breaker	MCA	Max Fuse Size or Max Circuit Breaker	MCA	Max Fuse Size or Max Circuit Breaker
3	WSC036H3	187-253	26	40	29	40	-	-
3	WSC036H4	414-506	11	15	13	15	-	-
3	WSC036HW	517-633	11	15	11	15	-	-
4	WSC048H3	187-253	27	40	28	40	-	-
4	WSC048H4	414-506	12	15	13	15	-	-
4	WSC048HW	517-633	12	15	12	15	-	-
5	WSC060H3	187-253	31	45	32	45	-	-
5	WSC060H4	414-506	15	20	15	20	-	-
5	WSC060HW	517-633	13	15	13	15	-	-
7.5	WSC092H3	187-253	40	60	46	70	44	60
7.5	WSC092H4	414-506	18	25	21	30	20	30
7.5	WSC092HW	517-633	14	20	16	20	20	25
8.5	WSC102H3	187-253	45	70	48	70	46	70
8.5	WSC102H4	414-506	20	30	22	30	21	30
8.5	WSC102HW	517-633	16	20	17	25	21	25
10	WSC120H3	187-253	54	80	-	-	-	-
10	WSC120H4	414-506	24	35	-	-	-	-
10	WSC120HW	517-633	23	30	-	-	-	-

(a) The standard motor for 3-phase models (3 to 5 and 10 ton) is a multispeed, direct drive motor. The standard motor for 3-phase (7.5 to 8.5 tons) is a belt drive motor.

**Table 110. Unit wiring - high efficiency**

Tons	Unit Model Number	Voltage Range	Standard Indoor Fan Motor <sup>(a)</sup>		Oversized Indoor Fan Motor	
			MCA	Max Fuse Size or Max Circuit Breaker	MCA	Max Fuse Size or Max Circuit Breaker
3	W/DHC036H3	187-253	23	30	20	30
3	W/DHC036H4	414-506	13	15	10	15
3	W/DHC036HW	517-633	9	15	—	—
4	W/DHC048H3	187-253	29	40	24	35
4	W/DHC048H4	414-506	14	15	11	15
4	W/DHC048HW	517-633	10	15	—	—
5	W/DHC060H3	187-253	32	45	27	40
5	W/DHC060H4	414-506	15	20	12	15
5	W/DHC060HW	517-633	12	15	—	—
6	W/DHC074H3	187-253	42	50	-	-
6	W/DHC074H4	414-506	19	25	-	-
6	W/DHC074HW	517-633	21	25	-	-
7.5	W/DHC092H3	187-253	43	50	-	-
7.5	W/DHC092H4	414-506	20	25	-	-
7.5	W/DHC092HW	517-633	22	25	-	-
8.5	W/DHC102H3	187-253	46	60	-	-

**Table 110. Unit wiring - high efficiency (continued)**

Tons	Unit Model Number	Voltage Range	Standard Indoor Fan Motor <sup>(a)</sup>		Oversized Indoor Fan Motor	
			MCA	Max Fuse Size or Max Circuit Breaker	MCA	Max Fuse Size or Max Circuit Breaker
8.5	W/DHC102H4	414-506	22	25	-	-
8.5	W/DHC102HW	517-633	23	25	-	-
10	W/DHC120H3	187-253	49	60	-	-
10	W/DHC120H4	414-506	24	30	-	-
10	W/DHC120HW	517-633	23	30	-	-

(a) The standard motor for all models is a multispeed, direct drive motor.

**Table 111. Unit wiring with electric heat (single point connection) - standard efficiency**

Tons	Unit Model Number	Heater Model Number	Heater kW Rating <sup>(a)</sup>	Control Stages	Standard Indoor Fan Motor		Oversized Indoor Fan Motor		Optional EBM Fan Motor	
					MCA	Max Fuse Size or Max Circuit Breaker	MCA	Max Fuse Size or Max Circuit Breaker	MCA	Max Fuse Size or Max Circuit Breaker
<b>208/230 Volts Three Phase</b>										
3	WSC036H3	BAYHTRE306*	4.5/6.0	1	42/44	50/50	44/47	50/50	-	-
3	WSC036H3	BAYHTRE312*	9.0/12.0	2	57/62	60/70	60/65	60/70	-	-
3	WSC036H3	BAYHTRY317*	13.1/17.4	2	71/78	80/80	74/81	80/90	-	-
4	WSC048H3	BAYHTRE306*	4.5/6.0	1	43/45	50/50	44/46	50/50	-	-
4	WSC048H3	BAYHTRE312*	9.0/12.0	2	58/63	60/70	63/68	60/70	-	-
4	WSC048H3	BAYHTRY317*	13.1/17.4	2	72/79	80/80	74/84	80/90	-	-
5	WSC060H3	BAYHTRX306*	4.5/6.0	1	47/50	60/60	48/50	60/60	-	-
5	WSC060H3	BAYHTRX312*	9.0/12.0	2	63/68	70/70	63/68	70/70	-	-
5	WSC060H3	BAYHTRY318*	13.1/17.4	2	77/84	80/90	77/84	80/90	-	-
5	WSC060H3	BAYHTRY323	17.3/23.0	2	91/101	100/110	92/101	100/110	-	-
7.5	WSC092H3	BAYHTRU309*	6.8/9.0	1	63/67	80/80	69/73	90/90	-	-
7.5	WSC092H3	BAYHTRA309*	6.8/9.0	1	-	-	-	-	67/71	80/90
7.5	WSC092H3	BAYHTRU318*	13.5/18.0	1	87/94	100/100	93/100	100/110	-	-
7.5	WSC092H3	BAYHTRA318*	13.5/18.0	1	-	-	-	-	91/98	100/110
7.5	WSC092H3	BAYHTRU327*	20.3/27.0	2	110/121	110/125	116/127	125/150	-	-
7.5	WSC092H3	BAYHTRA327*	20.3/27.0	2	-	-	-	-	114/125	125/125
7.5	WSC092H3	BAYHTRU336*	27.0/36.0	2	134/148	150/150	140/154	150/175	-	-
7.5	WSC092H3	BAYHTRA336*	27.0/36.0	2	-	-	-	-	138/152	150/175
8.5	WSC102H3	BAYHTRU309*	6.8/9.0	1	68/72	90/90	71/75	90/90	-	-
8.5	WSC102H3	BAYHTRA309*	6.8/9.0	1	-	-	-	-	69/73	90/90
8.5	WSC102H3	BAYHTRU318*	13.5/18.0	1	92/99	100/110	95/102	110/110	-	-
8.5	WSC102H3	BAYHTRA318*	13.5/18.0	1	-	-	-	-	93/100	110/110
8.5	WSC102H3	BAYHTRU327*	20.3/27.0	2	115/126	125/150	118/129	125/150	-	-
8.5	WSC102H3	BAYHTRA327*	20.3/27.0	2	-	-	-	-	116/127	125/150
8.5	WSC102H3	BAYHTRU336*	27.0/36.0	2	138/153	150/175	142/156	150/175	-	-
8.5	WSC102H3	BAYHTRA336*	27.0/36.0	2	-	-	-	-	139/154	150/175
10	WSC120H3	BAYHTRA318*	13.5/18.0	1	101/108	110/125	-	-	-	-



## Electrical Data

**Table 111. Unit wiring with electric heat (single point connection) - standard efficiency (continued)**

Tons	Unit Model Number	Heater Model Number	Heater kW Rating <sup>(a)</sup>	Control Stages	Standard Indoor Fan Motor		Oversized Indoor Fan Motor		Optional EBM Fan Motor	
					MCA	Max Fuse Size or Max Circuit Breaker	MCA	Max Fuse Size or Max Circuit Breaker	MCA	Max Fuse Size or Max Circuit Breaker
10	WSC120H3	BAYHTRA327*	20.3/27.0	2	124/135	125/150	-	-	-	-
10	WSC120H3	BAYHTRA336*	27.0/36.0	2	147/162	150/175	-	-	-	-
10	WSC120H3	BAYHTRA354*	40.6/54.0	2	194/184	200/200	-	-	-	-
<b>460 Volts Three Phase</b>										
3	WSC036H4	BAYHTRE406*	6	1	20	20	23	25	-	-
3	WSC036H4	BAYHTRE412*	12	2	29	30	32	35	-	-
3	WSC036H4	BAYHTRY417*	17.4	2	37	40	40	40	-	-
4	WSC048H4	BAYHTRE406*	6	1	21	25	22	25	-	-
4	WSC048H4	BAYHTRE412*	12	2	30	30	32	35	-	-
4	WSC048H4	BAYHTRY417*	17.4	2	38	40	40	40	-	-
5	WSC060H4	BAYHTRX406*	6	1	24	25	25	30	-	-
5	WSC060H4	BAYHTRX412*	12	2	33	35	34	35	-	-
5	WSC060H4	BAYHTRY418*	17.4	2	41	45	42	45	-	-
5	WSC060H4	BAYHTRY423*	23	2	50	50	51	60	-	-
7.5	WSC092H4	BAYHTRU409*	9	1	32	40	35	40	-	-
7.5	WSC092H4	BAYHTRA409*	9	1	-	-	-	-	34	40
7.5	WSC092H4	BAYHTRU418*	18	1	45	50	48	50	-	-
7.5	WSC092H4	BAYHTRA418*	18	1	-	-	-	-	47	50
7.5	WSC092H4	BAYHTRU427*	27	2	59	60	62	70	-	-
7.5	WSC092H4	BAYHTRA427*	27	2	-	-	-	-	61	70
7.5	WSC092H4	BAYHTRU436*	36	2	72	80	75	80	-	-
7.5	WSC092H4	BAYHTRA436*	36	2	-	-	-	-	74	80
8.5	WSC102H4	BAYHTRU409*	9	1	34	40	35	40	-	-
8.5	WSC102H4	BAYHTRA409*	9	1	-	-	-	-	34	40
8.5	WSC102H4	BAYHTRU418*	18	1	47	50	49	50	-	-
8.5	WSC102H4	BAYHTRA418*	18	1	-	-	-	-	48	50
8.5	WSC102H4	BAYHTRU427*	27	2	61	70	62	70	-	-
8.5	WSC102H4	BAYHTRA427*	27	2	-	-	-	-	61	70
8.5	WSC102H4	BAYHTRU436*	36	2	74	80	76	80	-	-
8.5	WSC102H4	BAYHTRA436*	36	2	-	-	-	-	75	80
10	WSC120H4	BAYHTRA418*	18	1	51	60	-	-	-	-
10	WSC120H4	BAYHTRA427*	27	2	64	70	-	-	-	-
10	WSC120H4	BAYHTRA436*	36	2	78	80	-	-	-	-
10	WSC120H4	BAYHTRA454*	54	2	89	100	-	-	-	-

**Table 111. Unit wiring with electric heat (single point connection) - standard efficiency (continued)**

Tons	Unit Model Number	Heater Model Number	Heater kW Rating <sup>(a)</sup>	Control Stages	Standard Indoor Fan Motor		Oversized Indoor Fan Motor		Optional EBM Fan Motor	
					MCA	Max Fuse Size or Max Circuit Breaker	MCA	Max Fuse Size or Max Circuit Breaker	MCA	Max Fuse Size or Max Circuit Breaker
<b>575 Volts Three Phase</b>										
3	WSC036HW	BAYHTREW06*	6	1	19	20	19	20	-	-
3	WSC036HW	BAYHTREW12*	12	2	26	30	26	30	-	-
3	WSC036HW	BAYHTRYW17*	17.4	2	32	35	32	35	-	-
4	WSC048HW	BAYHTREW06*	6	1	19	20	19	20	-	-
4	WSC048HW	BAYHTREW12*	12	2	26	30	26	30	-	-
4	WSC048HW	BAYHTRYW17*	17.4	2	33	35	33	35	-	-
5	WSC060HW	BAYHTREW06*	6	1	20	20	20	20	-	-
5	WSC060HW	BAYHTREW12*	12	2	27	30	27	30	-	-
5	WSC060HW	BAYHTREW18*	17.4	2	33	35	33	35	-	-
5	WSC060HW	BAYHTREW23*	23	2	40	40	40	40	-	-
7.5	WSC092HW	BAYHTRUW18*	18	1	36	40	38	40	-	-
7.5	WSC092HW	BAYHTRAW18*	18	1	-	-	-	-	42	45
7.5	WSC092HW	BAYHTRUW27*	27	2	47	50	49	50	-	-
7.5	WSC092HW	BAYHTRAW27*	27	2	-	-	-	-	53	60
7.5	WSC092HW	BAYHTRUW36*	36	2	58	60	60	60	-	-
7.5	WSC092HW	BAYHTRAW36*	36	2	-	-	-	-	64	70
8.5	WSC102HW	BAYHTRUW18*	18	1	38	40	39	40	-	-
8.5	WSC102HW	BAYHTRAW18*	18	1	-	-	-	-	43	45
8.5	WSC102HW	BAYHTRUW27*	27	2	49	50	49	50	-	-
8.5	WSC102HW	BAYHTRAW27*	27	2	-	-	-	-	54	60
8.5	WSC102HW	BAYHTRUW36*	36	2	59	60	60	60	-	-
8.5	WSC102HW	BAYHTRAW36*	36	2	-	-	-	-	64	70
10	WSC120HW	BAYHTRAW18*	18	1	44	50	-	-	-	-
10	WSC120HW	BAYHTRAW27*	27	2	55	60	-	-	-	-
10	WSC120HW	BAYHTRAW36*	36	2	66	70	-	-	-	-
10	WSC120HW	BAYHTRAW54*	54	2	75	80	-	-	-	-

(a) The standard motor for 3-phase models (3 to 5 and 10 ton) is a multispeed, direct drive motor. The standard motor for 3-phase (7.5 to 8.5 tons) is a belt drive motor.



## Electrical Data

**Table 112. Unit wiring with electric heat (single point connection) - high efficiency**

Tons	Unit Model Number	Heater Model Number	Heater kW Rating <sup>(a)</sup>	Control Stages	Standard Indoor Fan Motor		Oversized Indoor Fan Motor	
					MCA	Max Fuse Size or Max Circuit Breaker	MCA	Max Fuse Size or Max Circuit Breaker
<b>208/230 Volts Three Phase</b>								
3	WHC036H3	BAYHTRE306*	4.5/6.0	1	39/41	45/45	36/38	40/45
3	WHC036H3	BAYHTRE312*	9.0/12.0	2	55/59	60/60	52/56	60/60
3	WHC036H3	BAYHTRY317*	13.1/17.4	2	69/76	70/80	66/73	70/80
4	WHC048H3	BAYHTRX306*	4.5/6.0	1	45/47	50/50	39/42	45/50
4	WHC048H3	BAYHTRX312*	9.0/12.0	2	60/65	60/70	55/60	60/60
4	WHC048H3	BAYHTRY318*	13.1/17.4	2	74/81	80/90	69/76	70/80
5	WHC060H3	BAYHTRX306*	4.5/6.0	1	48/50	60/60	43/45	50/50
5	WHC060H3	BAYHTRX312*	9.0/12.0	2	63/68	70/70	58/63	60/70
5	WHC060H3	BAYHTRY318*	13.1/17.4	2	77/84	80/90	72/79	80/80
5	WHC060H3	BAYHTRY323*	17.3/23.0	2	92/101	100/110	87/96	90/100
6	WHC074H3	BAYHTRA309*	6.8/9.0	1	65/69	70/70	-	-
6	WHC074H3	BAYHTRA318*	13.5/18.0	1	89/96	90/100	-	-
6	WHC074H3	BAYHTRA327*	20.3/27.0	2	112/123	125/125	-	-
6	WHC074H3	BAYHTRA336*	27.0/36.0	2	136/150	150/150	-	-
7.5	WHC092H3	BAYHTRA309*	6.8/9.0	1	67/70	70/70	-	-
7.5	WHC092H3	BAYHTRA318*	13.5/18.0	1	90/97	90/100	-	-
7.5	WHC092H3	BAYHTRA327*	20.3/27.0	2	113/124	125/125	-	-
7.5	WHC092H3	BAYHTRA336*	27.0/36.0	2	137/151	150/175	-	-
8.5	WHC102H3	BAYHTRA309*	6.8/9.0	1	69/73	80/80	-	-
8.5	WHC102H3	BAYHTRA318*	13.5/18.0	1	93/100	100/100	-	-
8.5	WHC102H3	BAYHTRA327*	20.3/27.0	2	116/127	125/150	-	-
8.5	WHC102H3	BAYHTRA336*	27.0/36.0	2	140/154	150/175	-	-
10	WHC120H3	BAYHTRB318*	13.5/18.0	1	96/103	100/110	-	-
10	WHC120H3	BAYHTRB327*	20.3/27.0	2	119/130	125/150	-	-
10	WHC120H3	BAYHTRB336*	27.0/36.0	2	142/157	150/175	-	-
10	WHC120H3	BAYHTRB354*	40.6/54.0	2	189/179	200/200	-	-
<b>460 Volts Three Phase</b>								
3	WHC036H4	BAYHRTE406*	6	1	22	25	19	20
3	WHC036H4	BAYHTRE412*	12	2	31	35	28	30
3	WHC036H4	BAYHTRY417*	17.4	2	39	40	36	40
4	WHC048H4	BAYHTRX406*	6	1	23	25	20	20
4	WHC048H4	BAYHTRX412*	12	2	32	35	29	30
4	WHC048H4	BAYHTRY418*	17.4	2	40	40	37	40
5	WHC060H4	BAYHTRX406*	6	1	24	25	21	25
5	WHC060H4	BAYHTRX412*	12	2	33	35	30	30
5	WHC060H4	BAYHTRY418*	17.4	2	41	45	38	40
5	WHC060H4	BAYHTRY423*	23	2	49	50	47	50



**Table 112. Unit wiring with electric heat (single point connection) - high efficiency (continued)**

Tons	Unit Model Number	Heater Model Number	Heater kW Rating <sup>(a)</sup>	Control Stages	Standard Indoor Fan Motor		Oversized Indoor Fan Motor	
					MCA	Max Fuse Size or Max Circuit Breaker	MCA	Max Fuse Size or Max Circuit Breaker
6	WHC074H4	BAYHTRA409*	9	1	33	35	-	-
6	WHC074H4	BAYHTRA418*	18	1	47	50	-	-
6	WHC074H4	BAYHTRA427*	27	2	60	60	-	-
6	WHC074H4	BAYHTRA436*	36	2	74	80	-	-
7.5	WHC092H4	BAYHTRA409*	9	1	34	35	-	-
7.5	WHC092H4	BAYHTRA418*	18	1	47	50	-	-
7.5	WHC092H4	BAYHTRA427*	27	2	61	70	-	-
7.5	WHC092H4	BAYHTRA436*	36	2	74	80	-	-
8.5	WHC102H4	BAYHTRA409*	9	1	35	35	-	-
8.5	WHC102H4	BAYHTRA418*	18	1	49	50	-	-
8.5	WHC102H4	BAYHTRA427*	27	2	62	70	-	-
8.5	WHC102H4	BAYHTRA436*	36	2	76	80	-	-
10	WHC120H4	BAYHTRB418*	18	1	51	60	-	-
10	WHC120H4	BAYHTRB427*	27	2	64	70	-	-
10	WHC120H4	BAYHTRB436*	36	2	78	80	-	-
10	WHC120H4	BAYHTRB454*	54	2	89	90	-	-
<b>575 Volts Three Phase</b>								
3	WHC036HW	BAYHTREW12*	12	2	24	25	-	-
3	WHC036HW	BAYHTRYW17*	17.4	2	30	30	-	-
4	WHC048HW	BAYHTRXW06*	6	1	18	20	-	-
4	WHC048HW	BAYHTRXW12*	12	2	25	25	-	-
4	WHC048HW	BAYHTRYW18*	17.4	2	31	35	-	-
5	WHC060HW	BAYHTRXW06*	6	1	19	20	-	-
5	WHC060HW	BAYHTRXW12*	12	2	26	30	-	-
5	WHC060HW	BAYHTRYW18*	17.4	2	32	35	-	-
5	WHC060HW	BAYHTRYW23*	23	2	39	40	-	-
6	WHC074HW	BAYHTRAW18*	18	1	42	45	-	-
6	WHC074HW	BAYHTRAW27*	27	2	52	60	-	-
6	WHC074HW	BAYHTRAW36*	36	2	63	70	-	-
7.5	WHC092HW	BAYHTRAW18*	18	1	43	45	-	-
7.5	WHC092HW	BAYHTRAW27*	27	2	54	60	-	-
7.5	WHC092HW	BAYHTRAW36*	36	2	64	70	-	-
8.5	WHC102HW	BAYHTRAW18*	18	1	44	45	-	-
8.5	WHC102HW	BAYHTRAW27*	27	2	54	60	-	-
8.5	WHC102HW	BAYHTRAW36*	36	2	65	70	-	-
10	WHC120HW	BAYHTRBW18*	18	1	45	45	-	-
10	WHC120HW	BAYHTRBW36*	36	2	66	70	-	-
10	WHC120HW	BAYHTRBW54*	54	2	74	80	-	-

(a) The standard motor for all models is a multispeed, direct drive motor.



## Electrical Data

**Table 113. Electrical characteristics - compressor motor and condenser motor - 60 cycle - standard efficiency**

Tons	Unit Model Number	No.	Compressor Motors						Condenser Fan Motors					
			Volts	Phase	hp <sup>(a)</sup>	rpm	Amps <sup>(b)</sup>		No.	Volts	Phase	hp	Amps <sup>(b)</sup>	
							RLA	LRA					FLA	LRA
3	WSC036H3	1	208-230	3	3.2	3500	15	88	1	208-230	3	0.25	1.1	3.6
3	WSC036H4	1	460	3	3.2	3500	6.6	44	1	460	3	0.25	0.55	1.8
3	WSC036HW	1	575	3	3.2	3500	5.5	34	1	575	3	0.25	0.45	1.4
4	WSC048H3	1	208-230	3	3.8	3500	14.5	98	1	208-230	3	0.33	1.4	4.6
4	WSC048H4	1	460	3	3.8	3500	6.3	55	1	460	3	0.33	0.7	2.3
4	WSC048HW	1	575	3	3.8	3500	6	41	1	575	3	0.33	0.55	1.8
5	WSC060H3	1	208-230	3	4.7	3500	17.5	110	1	208-230	3	0.40	1.5	5.6
5	WSC060H4	1	460	3	4.7	3500	7.88	52	1	460	3	0.40	1.8	2.8
5	WSC060HW	1	575	3	4.7	3500	6.3	39	1	575	3	0.40	0.65	2.3
7.5	WSC092H3	1	208-230	3	8.6	3500	26.09	164	1	208-230	3	0.7	3.3	12.3
7.5	WSC092H4	1	460	3	8.6	3500	11.67	94	1	460	3	0.7	1.6	6.1
7.5	WSC092HW	1	575	3	8.6	3500	8.72	65	1	575	3	0.7	1.4	5.1
8.5	WSC102H3	1	208-230	3	9.2	3500	27.63	223	1	208-230	3	0.7	3.3	12.3
8.5	WSC102H4	1	460	3	9.2	3500	12.12	100	1	460	3	0.7	1.6	6.1
8.5	WSC102HW	1	575	3	9.2	3500	9.36	70	1	575	3	0.7	1.4	5.1
10	WSC120H3	1	208-230	3	10.5	3500	34	240	1	208-230	3	0.7	3.3	12.3
10	WSC120H4	1	460	3	10.5	3500	14.42	130	1	460	3	0.7	1.6	6.1
10	WSC120HW	1	575	3	10.5	3500	10.77	84	1	460	3	0.7	1.4	5.1

(a) hp for each compressor.

(b) Amp draw for each motor; multiply value by number of motors to determine total amps.

**Table 114. Electrical characteristics - compressor motor - 60 cycle - high efficiency**

Tons	Unit Model Number	No.	Voltage	Phase	hp <sup>(a)</sup>	Compressor Rated		
						LRA	RLA	MCC
3	W/DHC036H3	1	208-230	3	3.9	73	11.6	18.1
3	W/DHC036H4	1	460	3	3.8	38	5.7	8.9
3	W/DHC036HW	1	575	3	3.8	25.6	4	6.2
4	W/DHC048H3	1	208-230	3	4.3	83.1	14	21.9
4	W/DHC048H4	1	460	3	4.3	41	6.4	10
4	W/DHC048HW	1	575	3	4.3	33	4.6	7.1
5	W/DHC060H3	1	208-230	3	5.3	110	16.5	25.8
5	W/DHC060H4	1	460	3	5.3	52	7.2	11.3
5	W/DHC060HW	1	575	3	5.3	38.9	5.5	8.6
6	W/DHC074H3	2	208-230	3	2.3/4.5	88/88	14.2/13.2	22.1/20.6
6	W/DHC074H4	2	460	3	2.3/4.5	44/44	6.2/6	9.7/9.3
6	W/DHC074HW	2	575	3	2.3/4.5	30/30	5.1/4.2	7.9/6.5
7.5	W/DHC092H3	2	208-230	3	5.2/5.6	83.1/98	14/14.5	21.9/22.6
7.5	W/DHC092H4	2	460	3	5.2/5.6	41/55	6.4/6.3	10/9.9

**Table 114. Electrical characteristics - compressor motor - 60 cycle - high efficiency (continued)**

Tons	Unit Model Number	No.	Voltage	Phase	hp <sup>(a)</sup>	Compressor Rated		
						LRA	RLA	MCC
7.5	W/DHC092HW	2	575	3	5.2/5.6	33/41	4.6/6	7.1/9.4
8.5	W/DHC102H3	2	208-230	3	6/5.6	110/98	16.22/14.5	25.3/22.6
8.5	W/DHC102H4	2	460	3	6/5.6	52/55	7.63/6.3	11.9/9.9
8.5	W/DHC102HW	2	575	3	6/5.6	38.9/41	5.32/6	8.3/9.4
10	W/DHC120H3	2	208-230	3	7.5/6.5	136/110	17.56/16	27.4/24.9
10	W/DHC120H4	2	460	3	7.5/6.5	66.1/52	8.46/7.8	13.20/12.1
10	W/DHC120HW	2	575	3	7.5/6.5	55.3/38.9	6.35/5.7	9.9/8.9

(a) hp for each compressor.

**Table 115. Electrical characteristics - condenser fan motor - 60 cycle - high efficiency**

Tons	Unit Model Number	Motor Voltage	Motor Hz	Motor Phase	Condenser Rated		
					LRA	FLA	Bhp
3	W/DHC036H3	208-230	60	3	3.6	1.1	0.25
3	W/DHC036H4	460	60	3	1.8	0.55	0.25
3	W/DHC036HW	575	60	3	1.4	0.45	0.25
4	W/DHC048H3	208-230	60	3	5.6	1.5	0.4
4	W/DHC048H4	460	60	3	2.8	0.8	0.4
4	W/DHC048HW	575	60	3	2.3	0.65	0.4
5	W/DHC060H3	208-230	60	3	5.6	1.5	0.4
5	W/DHC060H4	460	60	3	2.8	0.8	0.4
5	W/DHC060HW	575	60	3	2.3	0.65	0.4
6	W/DHC074H3	208-230	60	3	12.3	3.3	0.7
6	W/DHC074H4	460	60	3	6.1	1.6	0.7
6	W/DHC074HW	575	60	3	5.1	1.4	0.7
7.5	W/DHC092H3	208-230	60	3	12.3	3.3	0.7
7.5	W/DHC092H4	460	60	3	6.1	1.6	0.7
7.5	W/DHC092HW	575	60	3	5.1	1.4	0.7
8.5	W/DHC102H3	208-230	60	3	12.3	3.3	0.7
8.5	W/DHC102H4	460	60	3	6.1	1.6	0.7
8.5	W/DHC102HW	575	60	3	5.1	1.4	0.7
10	W/DHC120H3	208-230	60	3	10.4	2.8	0.75
10	W/DHC120H4	460	60	3	5.2	1.4	0.75
10	W/DHC120HW	575	60	3	5.2	1.4	0.75

**Note:** Precedent™ unit nameplate FLA and catalog FLA may be different than actual condenser motor nameplate FLA for two reasons:  
 If multiple vendors for approved motor size are used, the highest FLA is used.  
 Actual condenser motor FLA may be determined through unit temperature and pressure testing.



## Electrical Data

**Table 116. Electrical characteristics - standard evaporator fan motor - 60 cycle - direct or belt drive standard efficiency**

Tons	Unit Model Number	Direct or Belt Drive	No.	Volts	Phase	hp	Amps	
							FLA	LRA
3	WSC036H3	Direct Drive	1	208-230	1	0.75	5.7	-
3	WSC036H4	Direct Drive	1	460	1	0.75	1.7	-
3	WSC036HW	Direct Drive	1	575	1	0.75	5.7	-
4	WSC048H3	Direct Drive	1	208-230	1	1.0	6.9	-
4	WSC048H4	Direct Drive	1	460	1	1.0	2.5	-
4	WSC048HW	Direct Drive	1	575	1	1.0	6.9	-
5	WSC060H3	Direct Drive	1	208-230	1	1.0	7.6	-
5	WSC060H4	Direct Drive	1	460	1	1.0	4.0	-
5	WSC060HW	Direct Drive	1	575	1	1.0	7.6	-
7.5	WSC092H3	Belt Drive	1	208-230	3	1	3.3	12.5
7.5	WSC092H4	Belt Drive	1	460	3	1	1.6	12.5
7.5	WSC092HW	Belt Drive	1	575	3	1	1.4	10
7.5	WSC092H3	Direct Drive	1	208-230	3	2.75	7.3	-
7.5	WSC092H4	Direct Drive	1	460	3	2.75	3.6	-
7.5	WSC092HW	Direct Drive	1	575	3	2.75	7.5	-
8.5	WSC102H3	Belt Drive	1	208-230	3	1	6.3	12.5
8.5	WSC102H4	Belt Drive	1	460	3	1	3.1	12.5
8.5	WSC102HW	Belt Drive	1	575	3	1	2.5	10
8.5	WSC102H3	Direct Drive	1	208-230	3	2.75	7.3	-
8.5	WSC102H4	Direct Drive	1	460	3	2.75	3.6	-
8.5	WSC102HW	Direct Drive	1	575	3	2.75	7.5	-
10	WSC120H3	Direct Drive	1	208-230	3	2.75	7.3	-
10	WSC120H4	Direct Drive	1	460	3	2.75	3.6	-
10	WSC120HW	Direct Drive	1	460	3	2.75	7.5	-

**Note:** WSC(036,048,060)HW utilize 230V evaporator motors.

**Table 117. Electrical characteristics - standard evaporator fan motor - 60 cycle - high efficiency**

Tons	Unit Model Number	Motor Voltage	Motor Hz	Phase	No.	Motor Rating		
						FLA	LRA	HP
3	W/DHC036H3	208-230	60	1	1	7.3	—	0.75
3	W/DHC036H4	460 <sup>(a)</sup>	60	1	1	4.3	—	0.75
3	W/DHC036HW	575 <sup>(b)</sup>	60	1	1	3.5	—	0.75
4	W/DHC048H3	208-230	60	1	1	9.4	—	1.00
4	W/DHC048H4	460 <sup>(a)</sup>	60	1	1	4.3	—	1.00
4	W/DHC048HW	575 <sup>(b)</sup>	60	1	1	3.5	—	1.00
5	W/DHC060H3	208-230	60	1	1	9.4	—	1.00
5	W/DHC060H4	460 <sup>(a)</sup>	60	1	1	4.3	—	1.00
5	W/DHC060HW	575 <sup>(b)</sup>	60	1	1	3.5	—	1.00
6	W/DHC074H3	208-230	60	1	1	7.3	-	2.75

**Table 117. Electrical characteristics - standard evaporator fan motor - 60 cycle - high efficiency (continued)**

Tons	Unit Model Number	Motor Voltage	Motor Hz	Phase	No.	Motor Rating		
						FLA	LRA	HP
6	W/DHC074H4	460	60	1	1	3.6	-	2.75
6	W/DHC074HW	575 <sup>(c)</sup>	60	1	1	7.5	-	2.75
7.5	W/DHC092H3	208-230	60	1	1	7.3	-	2.75
7.5	W/DHC092H4	460	60	1	1	3.6	-	2.75
7.5	W/DHC092HW	575 <sup>(c)</sup>	60	1	1	7.5	-	2.75
8.5	W/DHC102H3	208-230	60	1	1	7.3	-	2.75
8.5	W/DHC102H4	460	60	1	1	3.6	-	2.75
8.5	W/DHC102HW	575 <sup>(c)</sup>	60	1	1	7.5	-	2.75
10	W/DHC120H3	208-230	60	1	1	7.3	-	2.75
10	W/DHC120H4	460	60	1	1	3.6	-	2.75
10	W/DHC120HW	575 <sup>(c)</sup>	60	1	1	7.5	-	2.75

**Note:** Precedent™ unit nameplate FLA and catalog FLA may be different than actual evaporator motor nameplate FLA for two reasons:  
 If multiple vendors for approved motor size are used, the highest FLA is used.  
 Actual evaporator motor FLA may be determined through unit temperature and pressure testing.

- (a) Precedent 460V rated units utilize a high efficiency 230V evaporator fan motor powered through 480/240V transformer. Fan voltage/FLA rated at transformer input.
- (b) Precedent 575V rated units utilize a high efficiency 230V evaporator fan motor powered through 575/240V transformer. Fan voltage/FLA rated at transformer input.
- (c) Precedent 575V rated units utilize a high efficiency 460V evaporator fan motor powered through 575/460V transformer. Fan voltage/FLA rated at transformer input.

**Table 118. Electrical characteristics - oversized evaporator fan motor - 60 cycle - belt drive - standard efficiency**

Tons	Unit Model Number	Direct or Belt Drive	No.	Volts	Phase	hp	Amps	
							FLA	LRA
3	WSC036H3	Direct Drive	1	208-230	1	1.5	8.2	-
3	WSC036H4	Direct Drive	1	460	1	1.5	4.2	-
3	WSC036HW	Direct Drive	1	575	1	1.5	3.5	-
4	WSC048H3	Direct Drive	1	208-230	1	1.5	8.2	-
4	WSC048H4	Direct Drive	1	460	1	1.5	4.2	-
4	WSC048HW	Direct Drive	1	575	1	1.5	3.5	-
5	WSC060H3	Direct Drive	1	208-230	1	1.5	8.2	-
5	WSC060H4	Direct Drive	1	460	1	1.5	4.2	-
5	WSC060HW	Direct Drive	1	575	1	1.5	3.5	-
7.5	WSC092H3	Belt Drive	1	208-230	3	3	9.4	52.4
7.5	WSC092H4	Belt Drive	1	460	3	3	4.6	26.3
7.5	WSC092HW	Belt Drive	1	575	3	3	3.4	29.4
8.5	WSC102H3	Belt Drive	1	208-230	3	3	9.4	52.4
8.5	WSC102H4	Belt Drive	1	460	3	3	4.6	26.3
8.5	WSC102HW	Belt Drive	1	575	3	3	3.4	29.4

**Note:** WSC(036,048,060)HW utilize 230V evaporator motors.



## Electrical Data

**Table 119. Electrical characteristics - oversized evaporator fan motor - 60 cycle - high efficiency**

Tons	Unit Model Number	Motor Voltage	Motor Hz	Phase	No.	Motor Rating		
						FLA	LRA	HP
3	W/DHC036H3	208-230	60	3	1	4.3	—	1.50
3	W/DHC036H4	460	60	3	1	1.9	—	1.50
4	W/DHC048H3	208-230	60	3	1	4.3	—	1.50
4	W/DHC048H4	460	60	3	1	1.9	—	1.50
5	W/DHC060H3	208-230	60	3	1	4.3	—	1.50
5	W/DHC060H4	460	60	3	1	1.9	—	1.50

**Notes:**

1. Precedent oversized evaporator available only on 230V and 460V.
2. Precedent™ unit nameplate FLA and catalog FLA may be different than actual evaporator motor nameplate FLA for two reasons:  
If multiple vendors for approved motor size are used, the highest FLA is used.  
Actual evaporator motor FLA may be determined through unit temperature and pressure testing.

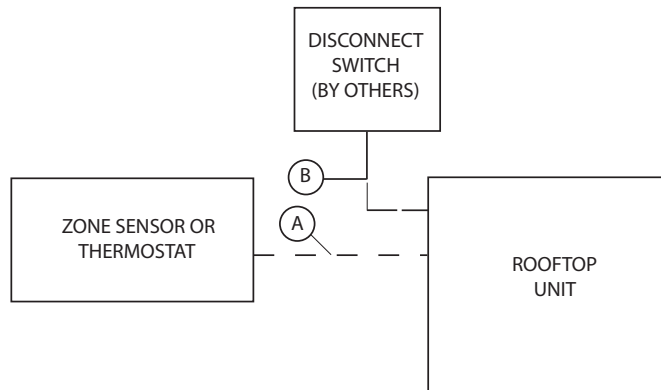
**Table 120. Electrical characteristics - inducer motor**

Unit Model Number	Stages	hp	rpm	volts	phase	LRA
DHC(036-120)H(3,4,W)*(L,X,M,Y,H,Z)	2	1/50	3200/3500	208-230	1	0.68
DHC074**(L,M,X,Y) DHC(092-102)**(L,X)	1	1/35	3000	208-230	1	0.6
DHC074**(H,Z) DHC(092-102)**(M,H,Y,Z) DHC120	2	1/15	3000/3350	208-230	1	0.4

# Jobsite Connections

**Table 121. Typical Number of Wires**

Zone Sensors		
A	Manual Changeover.....	4
	Manual/Auto Changeover.....	5
	Manual/Auto Changeover with Status Indication LED's.....	10
	Programmable Night Setback with Status Indication LED's.....	7
Thermostats		
A	3 Wires, 24V, Cooling only	
	4 Wires, 24V, with Electric Heat	
B	3 Power Wires + 1 Ground Wire (3-phase)	
	2 Power Wires + 1 Ground Wire (1-phase)	

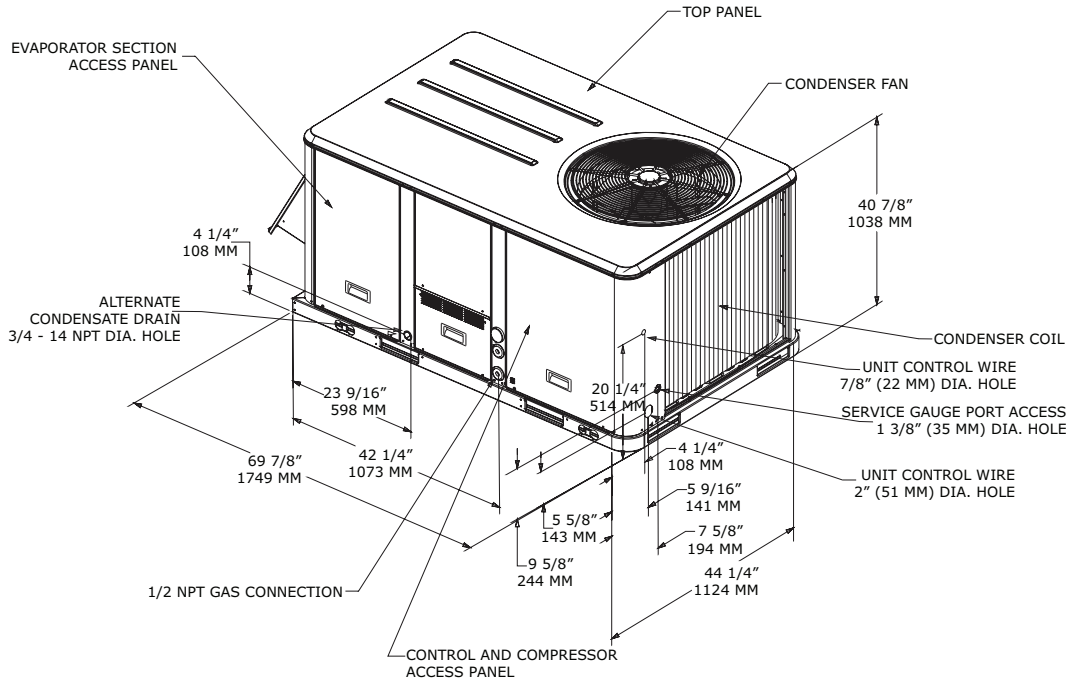


For specific wiring information, see the installation instructions.  
 All wiring except power wire is low voltage.  
 All customer supplied wiring to be copper and must conform to applicable electrical codes (such as NEC or CEC) and local electric codes. Wiring shown dotted is to be furnished and installed by the customer.

# Dimensional Data

**Figure 4. Heat pump - 3 to 4 tons standard efficiency, 3 ton high efficiency**

Note: 2" electrical connection: single point power when heat installed (W\*C)



**Figure 5. Heat pump - 3 to 4 tons standard efficiency, 3 ton high efficiency - downflow airflow supply/return - through-the-base utilities**

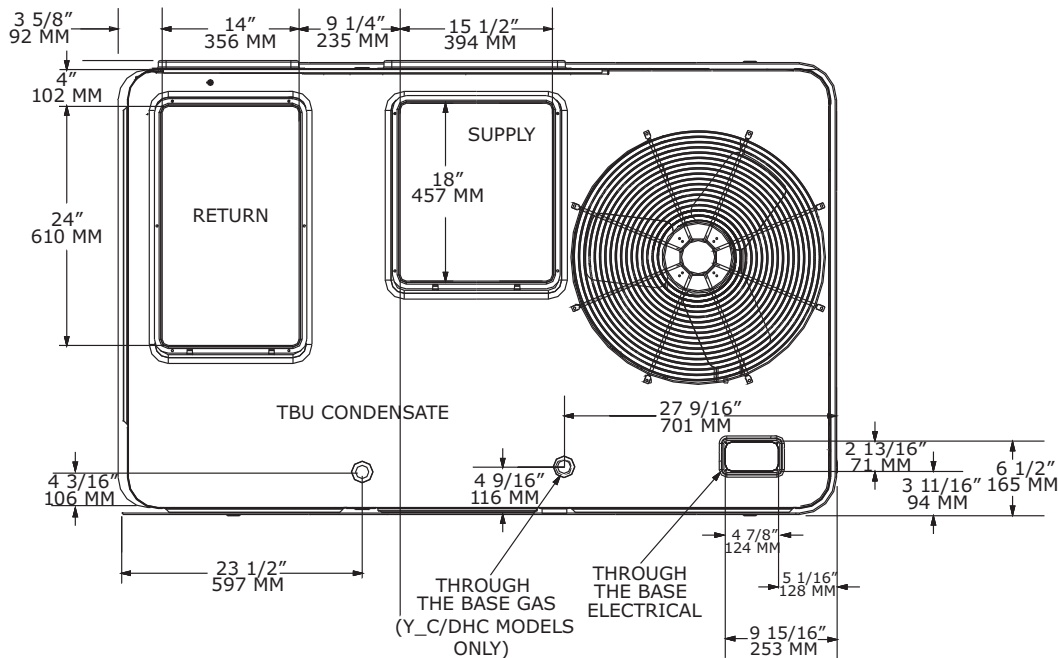




Figure 6. Heat pump - 3 to 4 tons standard efficiency, 3 ton high efficiency - horizontal airflow supply/return

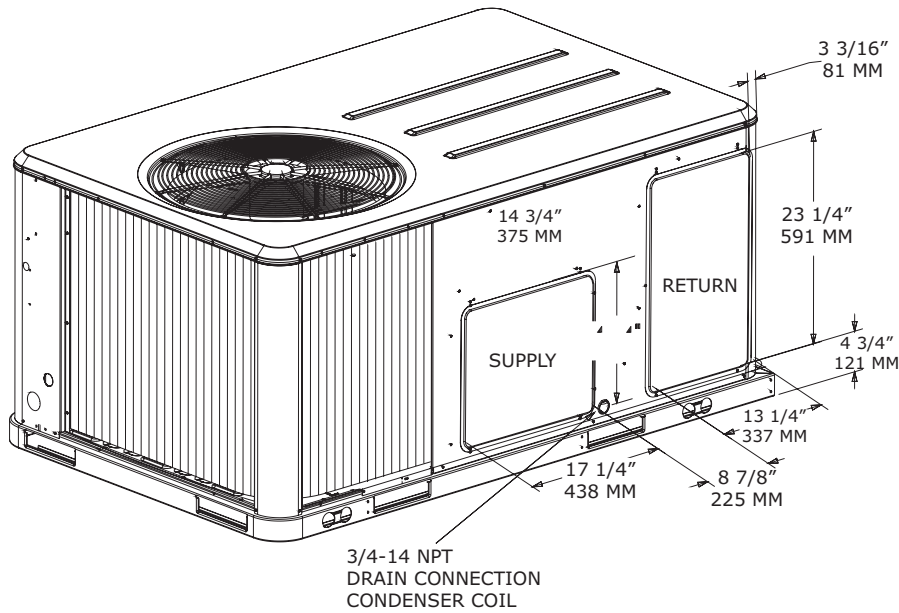
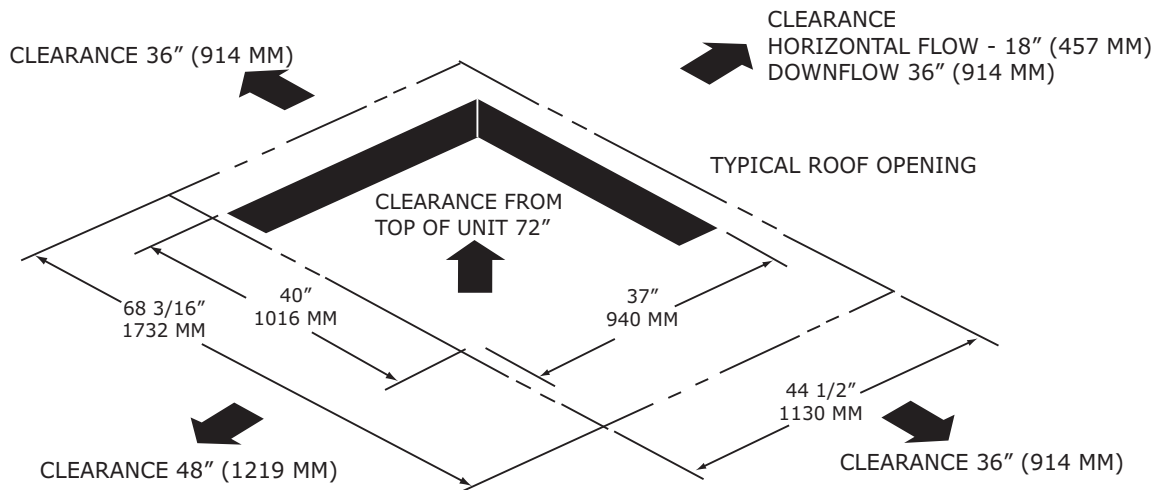
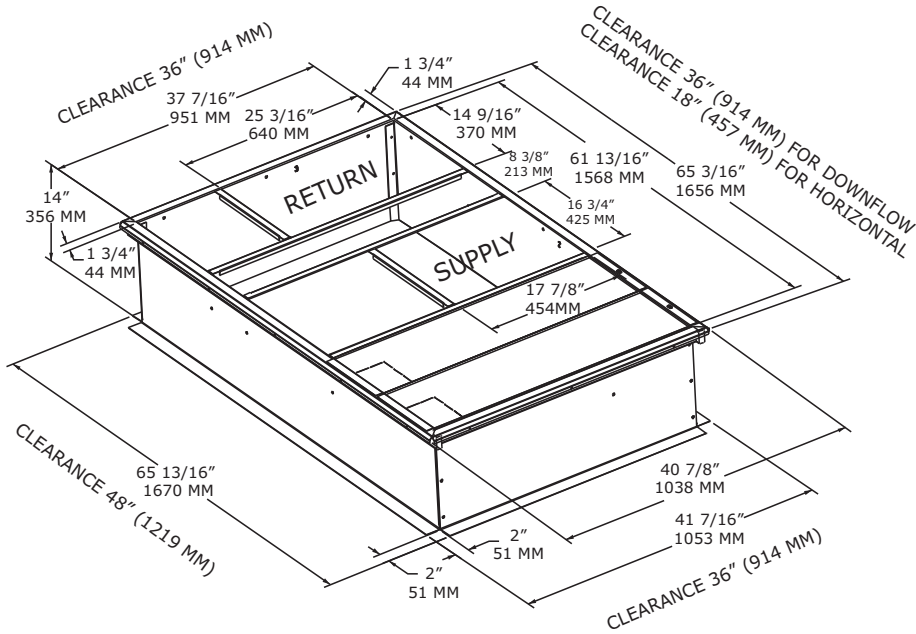


Figure 7. Heat pump - 3 to 4 tons standard efficiency, 3 ton high efficiency - unit clearance and roof opening



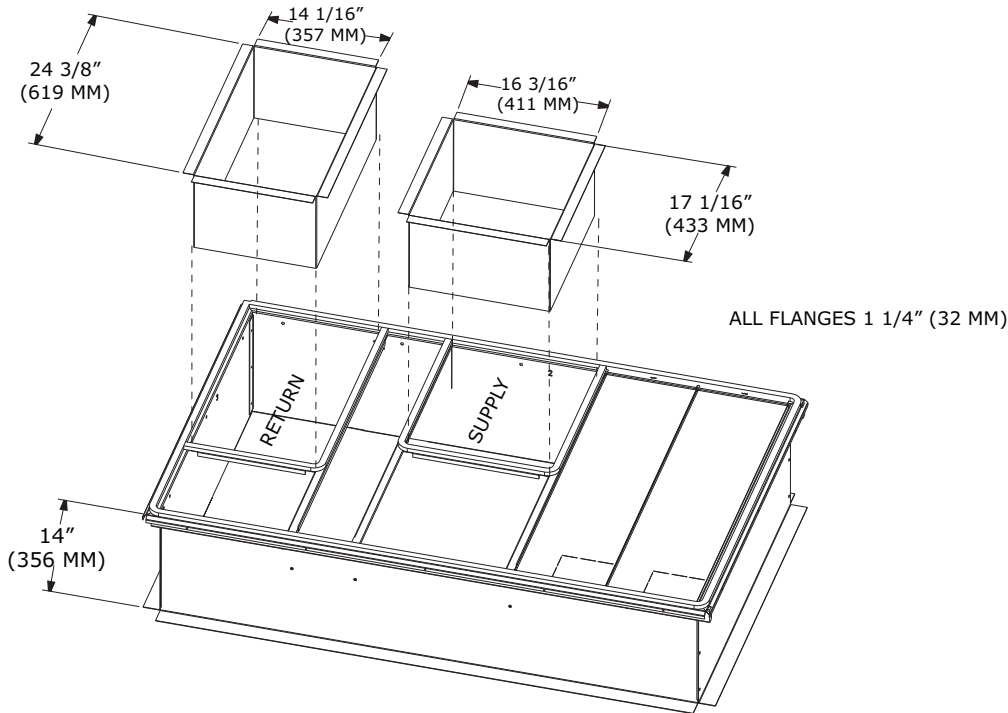
## Dimensional Data

**Figure 8. Heat pump - 3 to 4 tons standard efficiency, 3 ton high efficiency - roof curb**

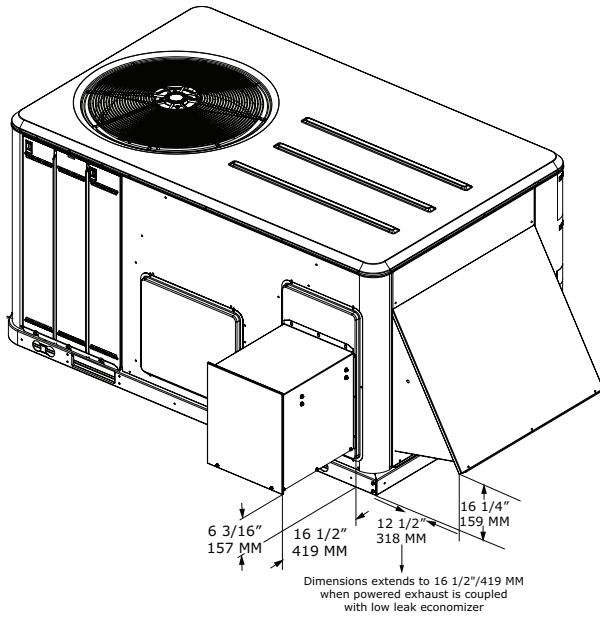


**Figure 9. Heat pump - 3 to 4 tons standard efficiency, 3 ton high efficiency - downflow duct connections - field fabricated**

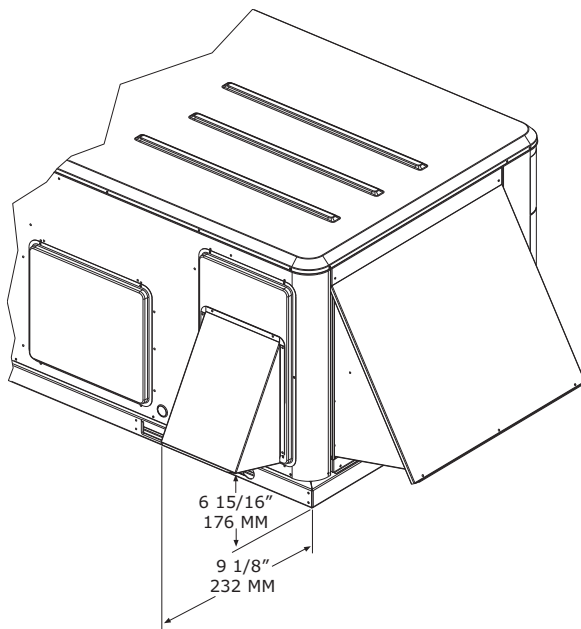
**Note:** Reference tabular information for duct clearance to combustible materials in the application consideration chapter.



**Figure 10. Heat pump - 3 to 4 tons standard efficiency, 3 ton high efficiency - economizer, manual or motorized fresh air damper; power exhaust**

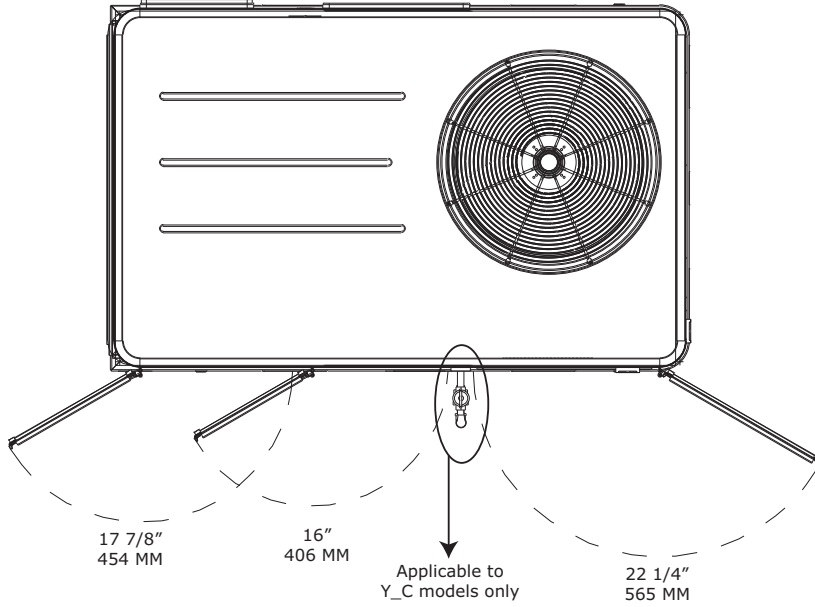


**Figure 11. Heat pump 3 to 4 tons standard efficiency, 3 ton high efficiency - economizer and barometric relief damper hood**



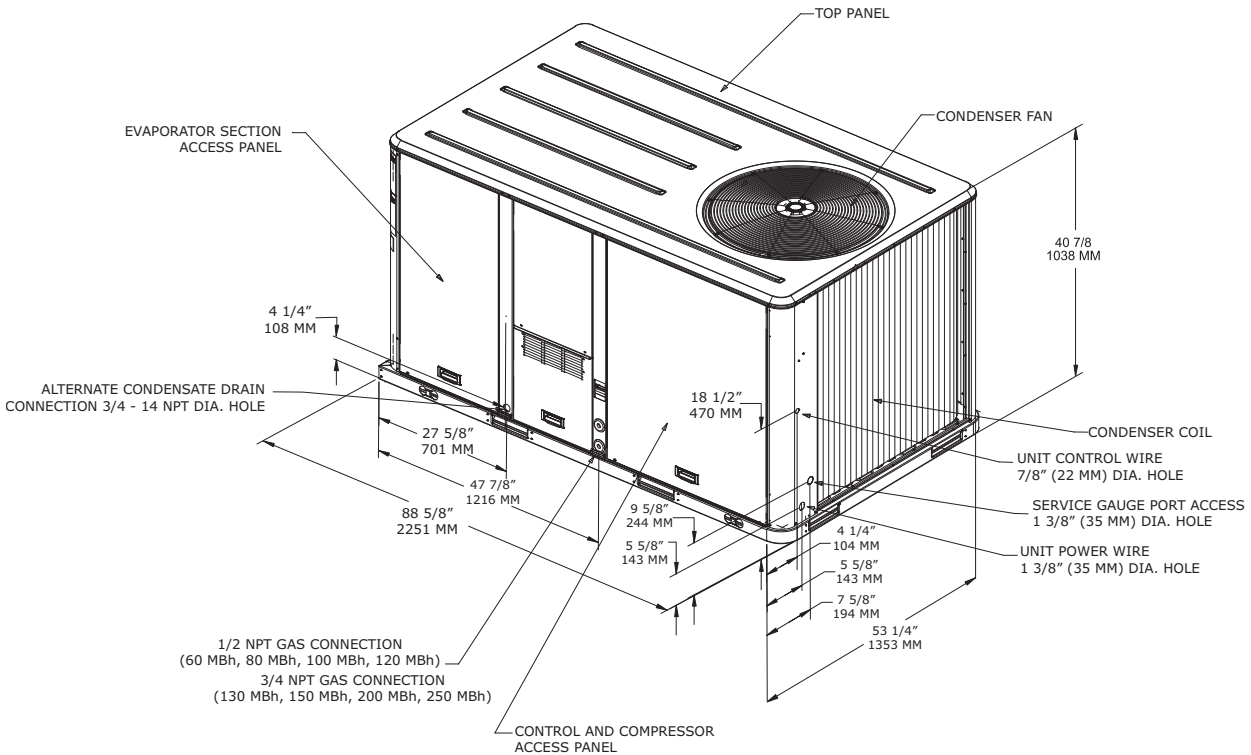
## Dimensional Data

**Figure 12. Heat pump - 3 to 4 tons standard efficiency, 3 ton high efficiency - swing diameter for hinged door(s) option**

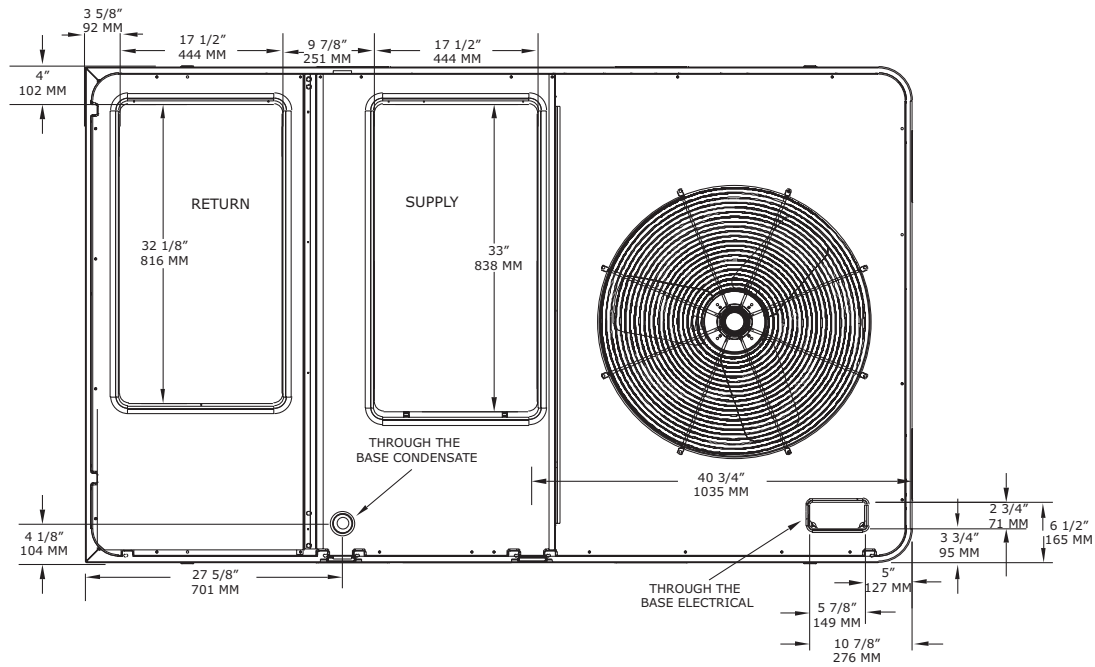


**Figure 13. Heat pump - 5 tons standard efficiency, 4 to 5 tons high efficiency**

Note: 2" electrical connection: single point power when heat installed (W°C)

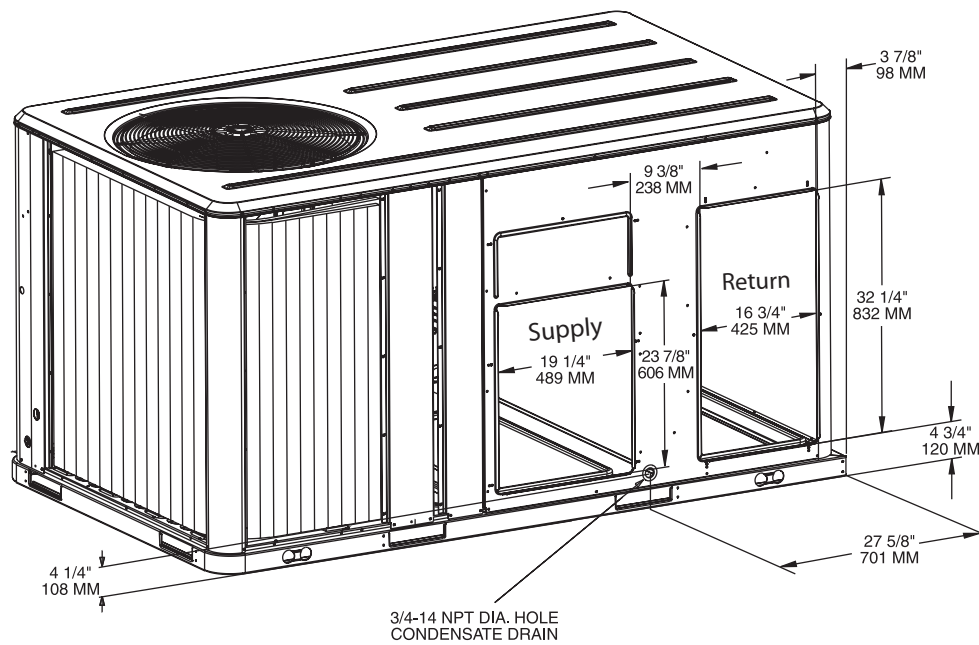


**Figure 14. Heat pumps - 5 to 10 tons standard efficiency, 4 to 8.5 tons high efficiency - downflow airflow supply/return - through-the-base utilities**



**Figure 15. Heat pumps - 5 to 10 tons standard efficiency, 4 to 8.5 tons high efficiency - horizontal airflow supply and return**

**Note:** All dimensions are in inches/millimeters.



## Dimensional Data

Figure 16. Heat pumps - 5 to 10 tons standard efficiency, 4 to 8.5 tons high efficiency - unit clearance and roof opening

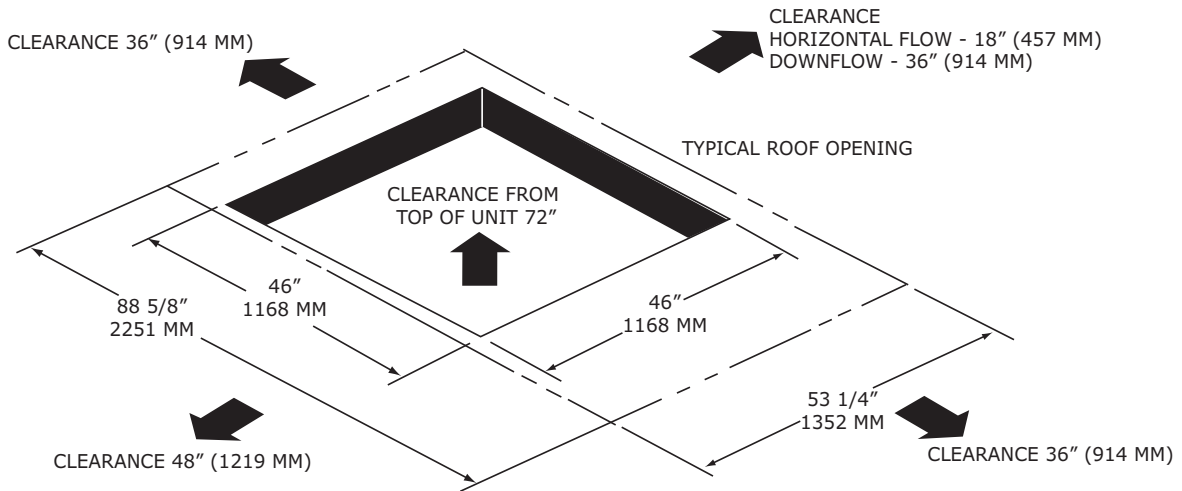
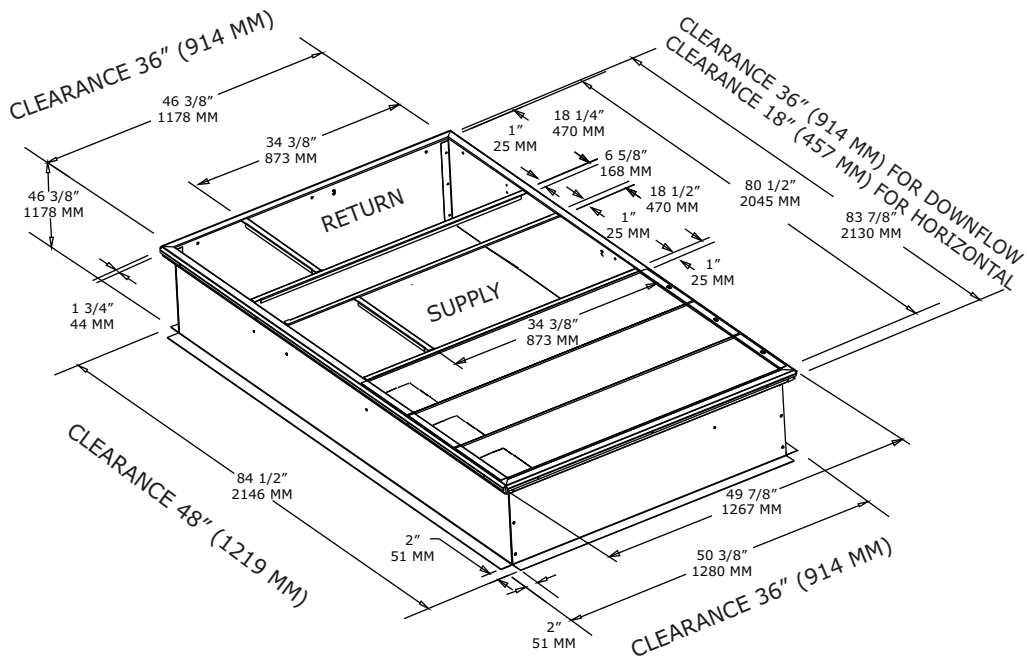
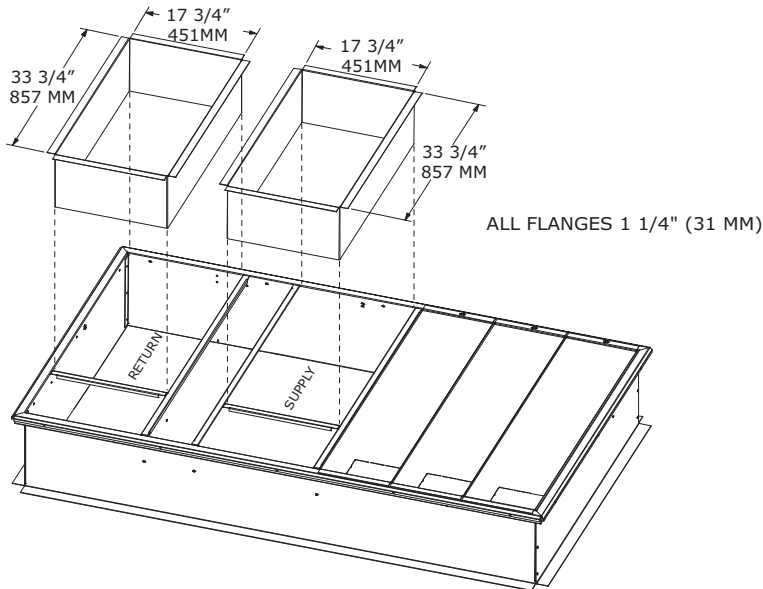


Figure 17. Heat pumps - 5 to 10 tons standard efficiency, 4 to 8.5 tons high efficiency - roof curb



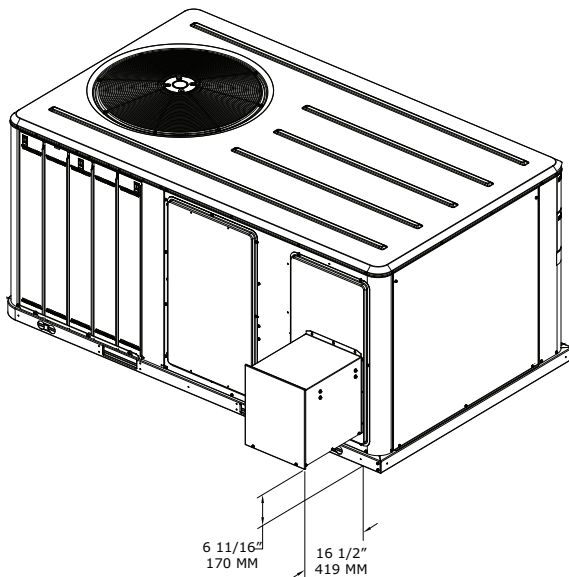
**Figure 18. Heat pumps - 5 to 10 tons standard efficiency, 4 to 8.5 tons high efficiency - downflow duct connections field fabricated**

**Note:** Reference tabular information for duct clearance to combustible materials in the application consideration chapter.



**Figure 19. Heat pumps - 5 to 10 tons standard efficiency, 4 to 8.5 tons high efficiency - power exhaust**

**Note:** Reference tabular information



## Dimensional Data

Figure 20. Heat pumps - 5 to 10 tons standard efficiency, 4 to 10 tons high efficiency - economizer, manual or motorized fresh air damper

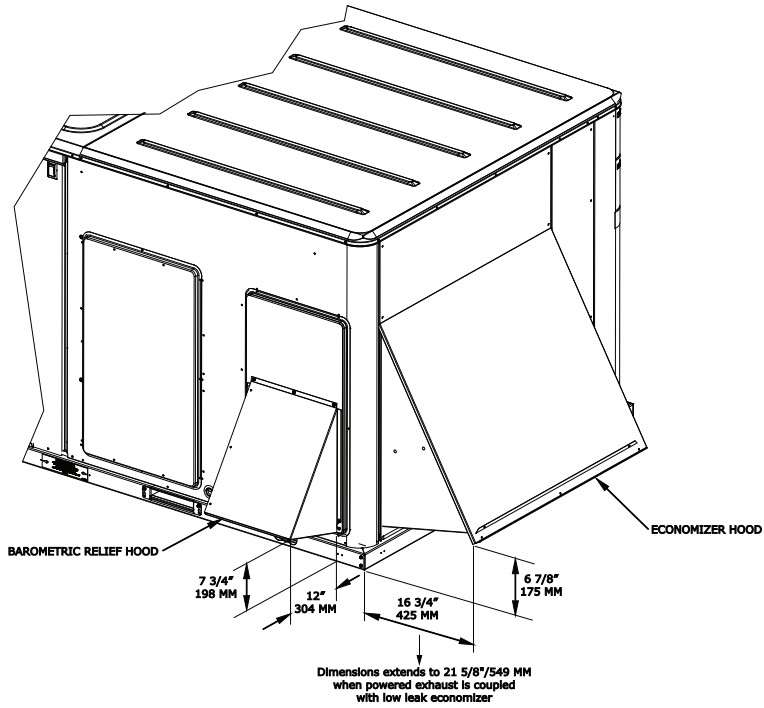


Figure 21. Heat pumps - 5 to 10 tons standard efficiency, 4 to 8.5 tons high efficiency - swing diameter for hinged door(s) option

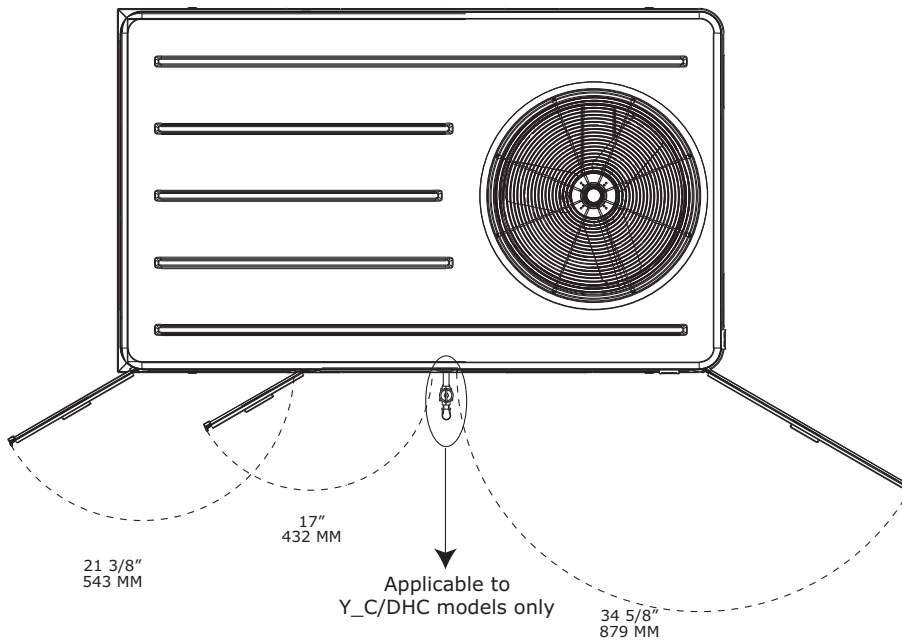




Figure 22. Heat pump - 7.5 to 10 tons standard efficiency and 7.5 to 8.5 tons high efficiency

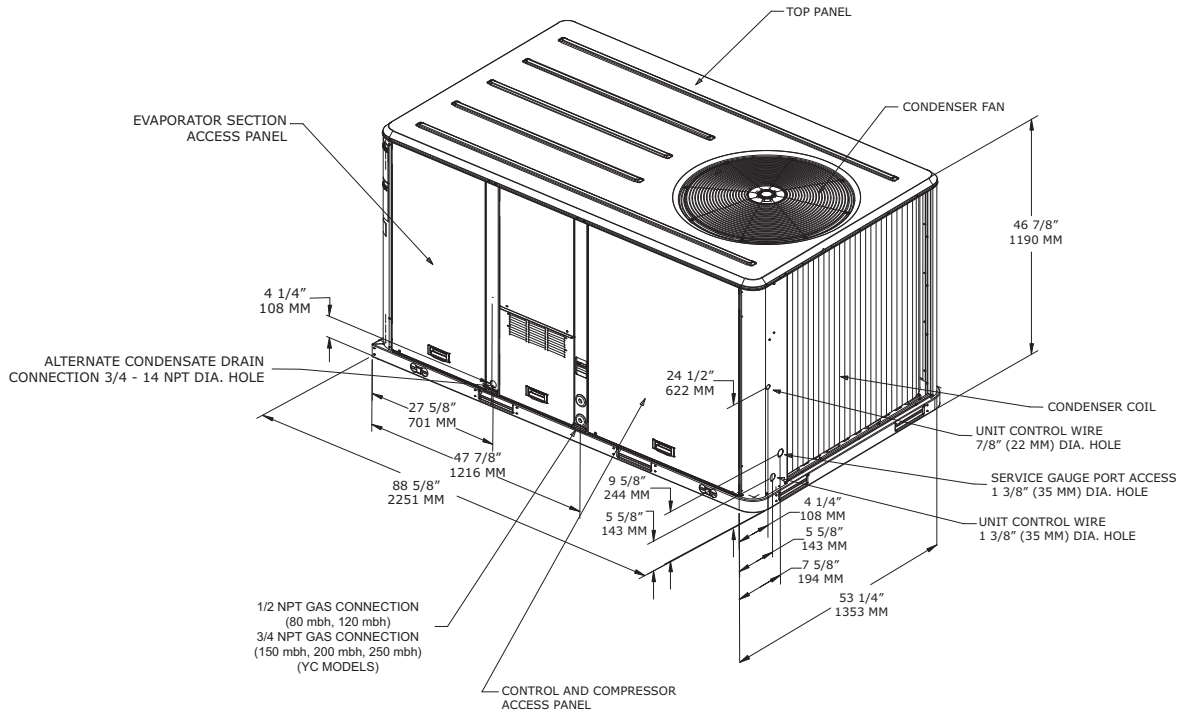
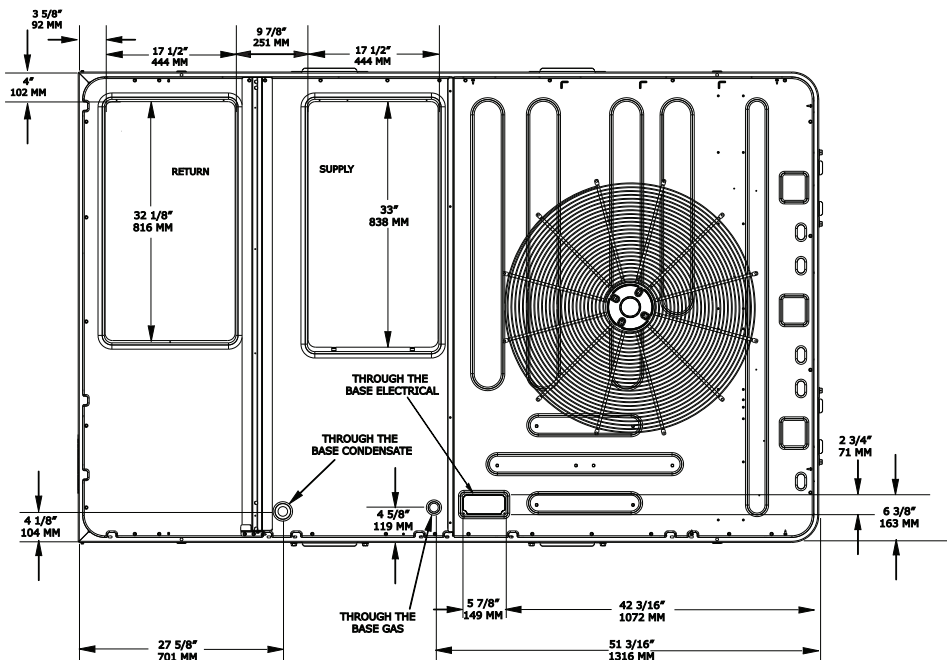


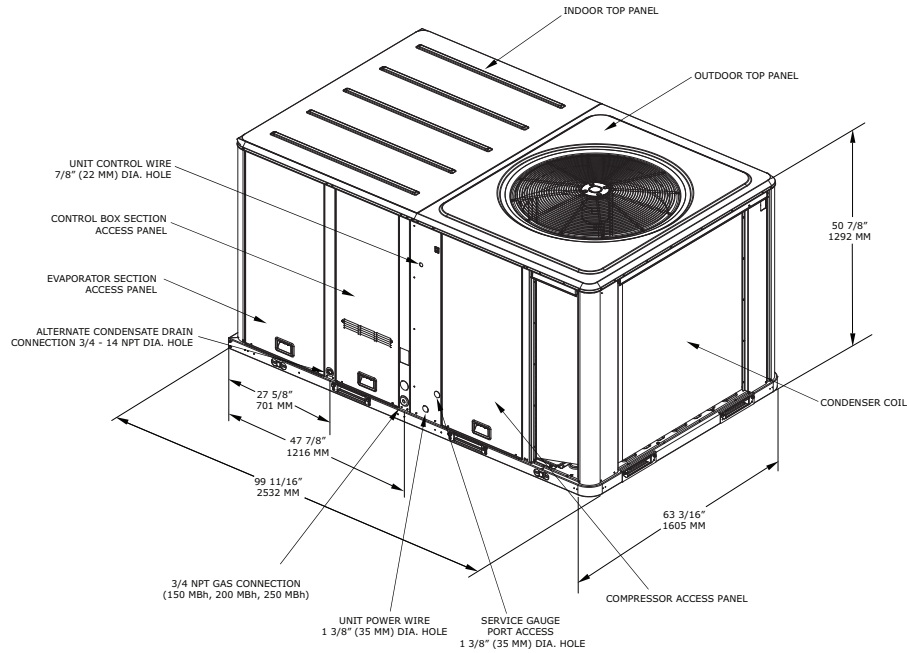
Figure 23. Heat pump - 10 tons high efficiency - downflow airflow supply/return through-the-base utilities



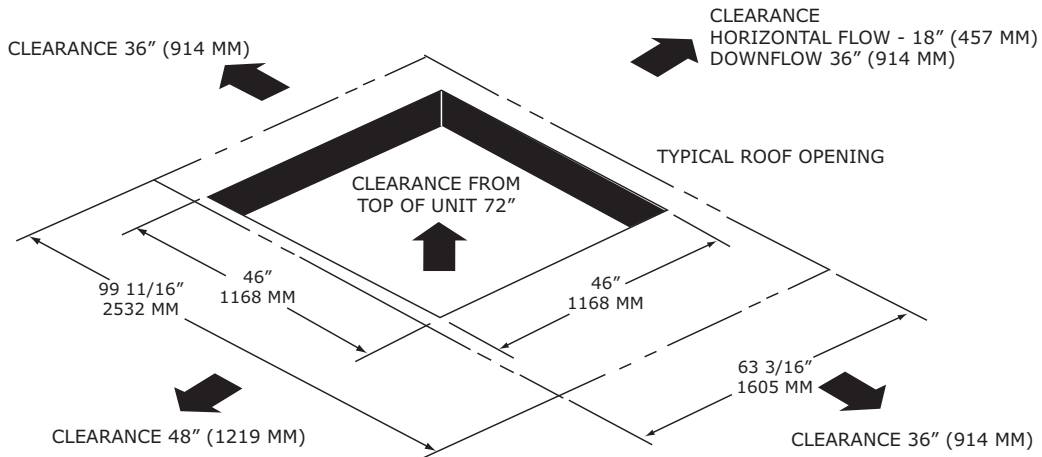
## Dimensional Data

**Figure 24. Heat pump - 10 tons high efficiency**

Note: 2" Electrical Connection: Single Point Power When Heat Installed.

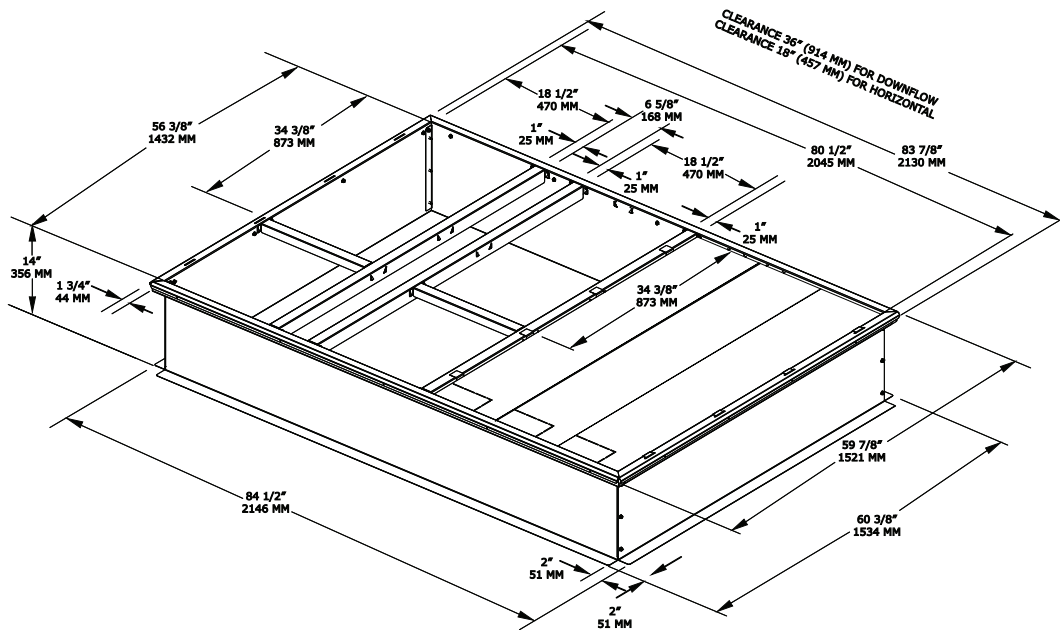


**Figure 25. Heat pump - 10 tons high efficiency - unit clearance and roof opening**



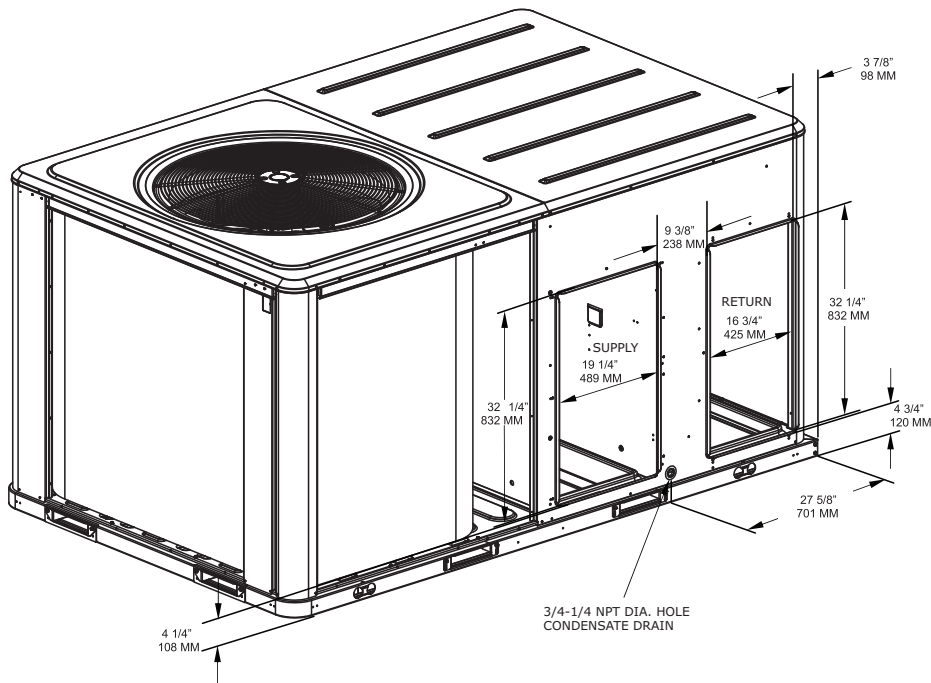
**Figure 26. Heat pump - 10 tons high efficiency - roof curb**

Note: 2" Electrical Connection: Single Point Power When Heat Installed.



**Figure 27. Heat pump - 10 tons high efficiency - horizontal airflow supply and return**

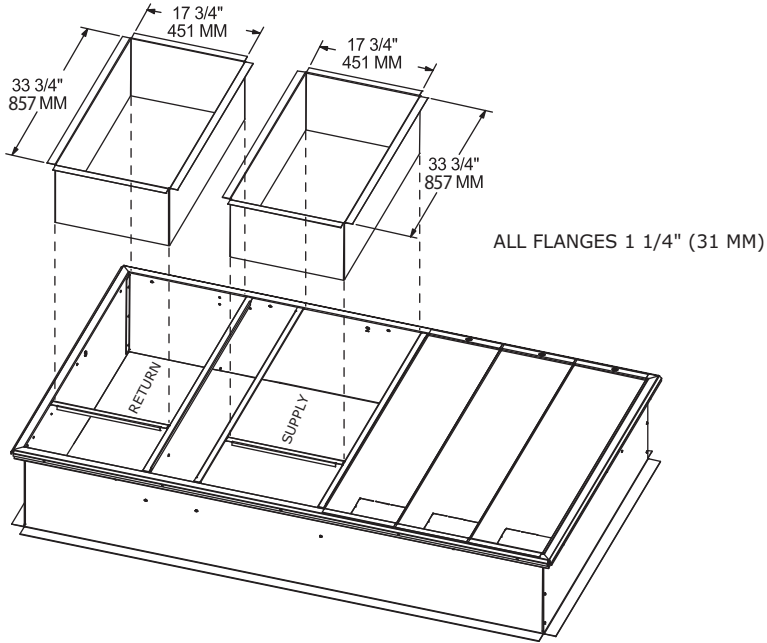
Note: All dimensions are in inches/millimeters.



## Dimensional Data

**Figure 28. Heat pump - 10 tons high efficiency - downflow duct connections (field fabricated)**

**Note:** Reference tabular information for duct clearance to combustible materials in the application consideration chapter.



**Figure 29. Heat pump - 10 tons high efficiency - power exhaust**

**Note:** Reference tabular information

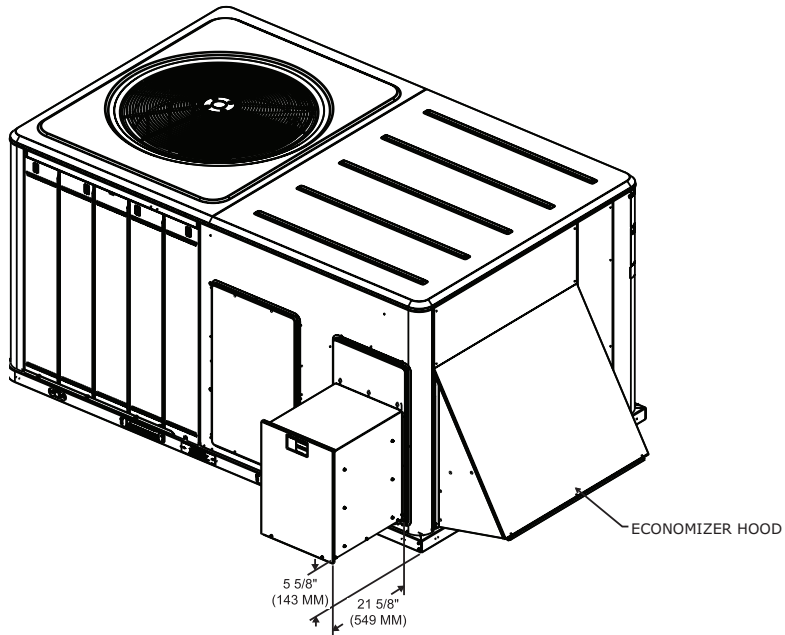
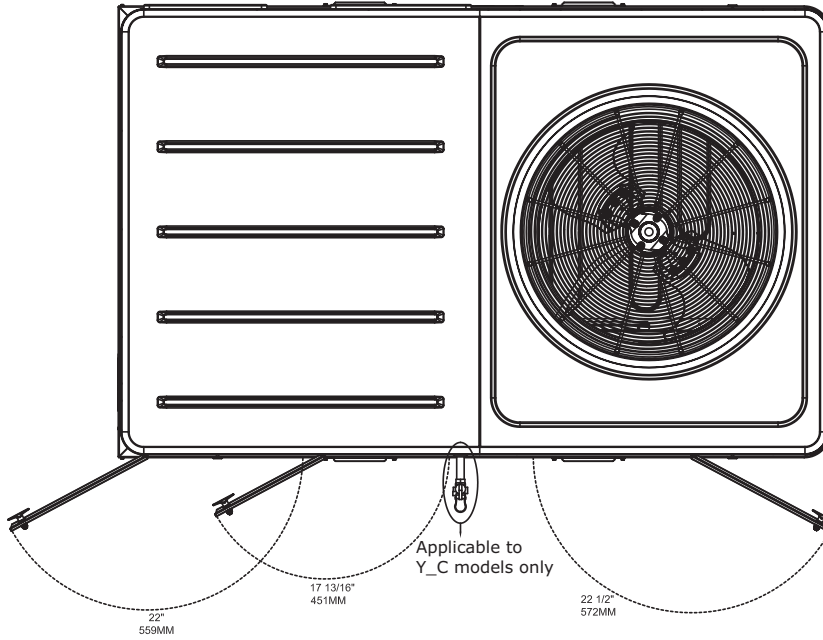


Figure 30. Heat pump - 10 tons high efficiency - swing diameter for hinged door(s) option

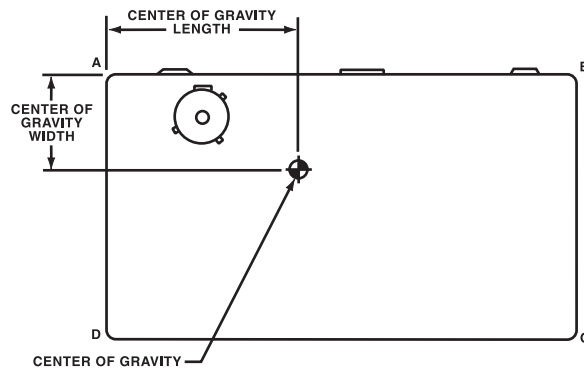


# Weights

**Table 122. Maximum unit and corner weights (lbs) and center of gravity dimensions (in.)**

Tons	Unit	Maximum Model Weights <sup>(a)</sup>		Corner Weights <sup>(b)</sup>				Center of Gravity (in.)	
	Model No.	Shipping	Net	A	B	C	D	Length	Width
3	WSC036H	612	507	144	122	110	130	32	21
4	WSC048H	645	540	165	131	108	136	31	20
5	WSC060H	777	682	228	177	114	163	38	22
7.5	WSC092H	894	796	252	204	163	177	41	23
8.5	WSC102H	927	829	286	183	195	164	40	23
10	WSC120H	948	850	303	170	218	159	40	24
3	WHC036H	619	514	142	120	111	142	31	22
4	WHC048H	768	673	222	175	114	162	38	22
5	WHC060H	773	678	225	176	114	162	38	22
3	DHC036H	658	553	145	137	125	145	33	22
4	DHC048H	845	750	234	192	146	178	40	23
5	DHC060H	849	754	235	193	147	179	40	23
6	WHC074H	927	829	193	295	65	276	38	22
7.5	WHC092H	927	829	193	295	65	276	38	22
8.5	WHC102H	953	855	199	306	67	283	39	22
10	WHC120H	1433	1228	357	343	259	269	49	27
6	DHC074H	990	892	216	324	69	283	39	21
7.5	DHC092H	1004	906	218	330	70	288	39	21
8.5	DHC102H	1016	918	220	336	70	292	39	21
10	DHC120H	1499	1294	402	313	290	289	47	28

(a) Weights are approximate.  
 (b) Corner weights are given for information only.



**Table 123. Factory installed options (fiops)/accessory net weights (lbs)<sup>(a),(b)</sup>**

Accessory	WSC036H-048H, D/WHC036H Net Weight 3 to 4 Tons	WSC060H, D/WHC048-060H Net Weight 4 to 5 Tons	WSC092H-120H W/DHC074-102H Net Weight 6 to 10 Tons	D/WHC120H Net Weight 10 Tons
460V/575V IDM Transformer <sup>(c)</sup>	29	29	—	—
Barometric Relief	7	10	10	10
Coil Guards	12	20	20	30
Economizer	26	36	36	36
Electric Heaters <sup>(d)</sup>	15	30	30/44 <sup>(e)</sup>	50
Hinged Doors	10	12	12	12
Low Leak Economizer	70	91	91	91
Manual Outside Air Damper	16	26	26	26
Motorized Outside Air Damper	20	30	30	30
Oversized Motor	5	8	8	—
Powered Convenience Outlet	38	38	38	50
Powered Exhaust	40	80	80	80
Roof Curb	61	105	105	111
Smoke Detector, Supply	5	5	5	5
Smoke Detector, Return	7	7	7	7
Stainless Steel Heat Exchanger <sup>(f)</sup>	4	6	—	—
Through-the-Base Electrical	8	13	13	13
Through-the-Base Gas <sup>(f)</sup>	5	5	—	—
Traq Dampers	10	15	15	15
Unit Mounted Circuit Breaker	5	5	5	5
Unit Mounted Disconnect	5	5	5	5

(a) Weights for options not listed are <5 lbs.

(b) Net weight should be added to unit weight when ordering factory-installed accessories.

(c) Applicable to D/WHC 460/575V units.

(d) Applicable to heat pump units only (W°C).

(e) Larger weight applies to units with variable speed fan.

(f) Applicable to dual fuel units only (D°C).



# Mechanical Specifications

## Standard

### General

Packaged rooftop units cooling, heating capacities, and efficiencies are AHRI Certified within scope of AHRI Standard 210-240 for 3 to 5 tons units or 340-360 (I-P) or 6 to 10 tons units and ANSIZ21.47 and 10 CFR Part 431 pertaining to Commercial Warm Air Furnaces (all gas heating units). The units shall be convertible airflow. The operating range shall be between 115°F and 0°F in cooling as standard from the factory for units with microprocessor controls. All units shall be factory assembled, internally wired, fully charged with R-410A, and 100 percent run tested to check cooling operation, fan and blower rotation, and control sequence before leaving the factory. Wiring internal to the unit shall be colored and numbered for simplified identification. Units shall be cULus listed and labeled, classified in accordance for Central Cooling Air Conditioners.

### Casing

Unit casing shall be constructed of zinc coated, heavy gauge, galvanized steel. Exterior surfaces shall be cleaned, phosphatized, and finished with a weather-resistant baked enamel finish. Unit's surface shall be tested 500 hours in a salt spray test in compliance with ASTM B117. Cabinet construction shall allow for all maintenance on one side of the unit. Service panels shall have lifting handles and be removed and reinstalled by removing two fasteners while providing a water and air tight seal. All exposed vertical panels and top covers in the indoor air section shall be insulated with a cleanable foil-faced, fire-retardant permanent, odorless glass fiber material. The base of the unit shall be insulated with 1/8 inch, foil-faced, closed-cell insulation. All insulation edges shall be either captured or sealed. The unit's base pan shall have no penetrations within the perimeter of the curb other than the raised 1 1/8 inch high downflow supply/return openings to provide an added water integrity precaution, if the condensate drain backs up. The base of the unit shall have provisions for forklift and crane lifting, with forklift capabilities on three sides of the unit.

### Compressors

All units shall have direct-drive, hermetic, scroll type compressors with centrifugal type oil pumps. Motor shall be suction gas-cooled and shall have a voltage utilization range of plus or minus 10 percent of unit nameplate voltage. Internal overloads shall be provided with the scroll compressors.

### Crankcase Heaters

These band heaters provide improved compressor reliability by warming the oil to prevent migration during off-cycles or low ambient conditions.

### Controls

Unit shall be completely factory-wired with necessary controls and contactor pressure lugs or terminal block for power wiring. Unit shall provide an external location for mounting a fused disconnect device.

Microprocessor controls shall be standard.

Microprocessor controls provide for all 24V control functions. The resident control algorithms shall make all heating, cooling, and/or ventilating decisions in response to electronic signals from sensors measuring indoor and outdoor temperatures. The control algorithm maintains accurate temperature control, minimizes drift from set point, and provides better building comfort. A centralized microprocessor shall provide anti-short cycle timing and time delay between compressors to provide a higher level of machine protection.

Units shall have single point power entry as standard.



## Evaporator and Condenser Coils

Internally finned, 5/16-inch copper tubes mechanically bonded to a configured aluminum plate fin shall be standard. Coils shall be leak tested at the factory to ensure the pressure integrity. The evaporator coil and condenser coil shall be leak tested to 600 psig. The assembled unit shall be leak tested to 465 psig. The condenser coil shall have a patent pending 1+1+1 hybrid coil designed with slight gaps for ease of cleaning. A plastic, dual-sloped, removable and reversible condensate drain pan with through-the-base condensate drain is standard.

## Filters

Throwaway filters shall be standard on all units. Optional 2-inch MERV 8 and MERV 13 filters shall also be available.

## High Pressure Control

All units include High Pressure Cutout as standard.

## Indoor Fan

Standard efficiency 6 to 8.5 tons units come standard with belt drive motors with an adjustable idler-arm assembly for quick-adjustment to fan belts and motor sheaves. All high efficiency and 10 tons standard efficiency shall have variable speed direct drive motors. All motors shall be thermally protected. All indoor fan motors meet the U.S. Energy Policy Act of 1992 (EPACT).

## Outdoor Fans

The outdoor fan shall be direct-drive, statically balanced, draw-through in the vertical discharge position. The fan motor shall be permanently lubricated and shall have built-in thermal overload protection.

## Phase Monitoring Protection

Precedent™ units with 3-phase power are equipped with phase monitoring protection as standard. These devices protect motors and compressors against problems caused by phase loss, phase imbalance and phase reversal indication.

## Plenum Fan

Select 6 to 10 tons models are equipped with a direct drive plenum fan design. Plenum fan design shall include a backward-curved fan wheel along with an external rotor direct drive variable speed indoor motor. All plenum fan designs will have a variable speed adjustment potentiometer located in the control box.

## Refrigerant Circuits

Each refrigerant circuit offer thermal expansion valve as standard. Service pressure ports, and refrigerant line filter driers are factory-installed as standard. An area shall be provided for replacement suction line driers.

## Unit Top

The top cover shall be one piece construction or where seams exist, it shall be double-hemmed and gasket-sealed. The ribbed top adds extra strength and prevents water from pooling on unit top.

## Factory Installed Options

### Black Epoxy Pre-Coated Coils

The black epoxy coils have a thermoset vinyl coating that is bonded to the aluminum fin stock prior to the fin-stamping process. The pre-coated coils are an economical option for protection in mildly corrosive environments.



## Mechanical Specifications

---

### CO<sub>2</sub> Sensor Wiring

Factory-installed CO<sub>2</sub> sensor wiring saves time and ensures proper unit connections for the field installed CO<sub>2</sub> sensor kits.

### Condensate Overflow Switch

This option shall shut the unit down in the event that a clogged condensate drain line prevents proper condensate removal from the unit.

### Fault Detection and Diagnostics (FDD)

This offering meets the mandatory requirement of CA Title 24 of fully configurable diagnostics allowing fault history and reading fault codes at the unit. This option provides detection of the following faults: Air temperature sensor failure/fault and notification of acceptable economizer mode. The FDD system shall be certified by the Energy Commission as meeting the requirements.

### Gas Heating Section

**Note:** *Applicable to Dual Fuel units.*

The heating section has a progressive tubular heat exchanger design using stainless steel burners and corrosion resistant steel throughout. An induced draft combustion blower is used to pull the combustion products through the firing tubes. The heater uses a direct spark ignition (DSI) system, on initial call for heat, the combustion blower purges the heat exchanger for 20 seconds before ignition. After three unsuccessful ignition attempts, the entire heating system will be locked out until manually reset at the thermostat/zone sensor.

**Important:** *For installation in SCAQMD only (3 to 5 tons only): This furnace does not meet the SCAQMD Rule 1111 14 ng/J NO<sub>x</sub> emission limit, and thus is subject to a mitigation fee of up to \$450. This furnace is not eligible for the Clean Air Furnace Rebate Program: [www.CleanAirFurnaceRebate.com](http://www.CleanAirFurnaceRebate.com)*

### Hinged Access Doors

Sheet metal hinges are available on the filter/evaporator, supply fan/heat, and the compressor/control access doors. A compressor isolation panel is included to ease commissioning and servicing of units.

### High Static Motor

Oversized motor for applications where higher external static pressure capability is required. 3 to 5 tons standard efficiency units shall offer direct drive constant torque motors. 3 to 5 tons high efficiency shall offer direct drive constant CFM motors. 6 to 8.5 tons standard efficiency units shall offer belt drive motors.

### Human Interface

The Human Interface shall have a 5 inch color touchscreen display that conforms to FCC Part 15 Class B with an Ingress Protection Rating of IP24. The display text shall be readable by a person with 20/20 vision at a distance of 3 feet and 60° angle at lighting levels ranging from 100 lux - 25,000 lux. Also, the display shall operate at temperatures of -40° C to 70° C. Firmware and unit configurations shall be able to be restored via a USB storage device.

### Multiple-Zone VAV Control

Multiple-zone VAV control shall vary the speed of the indoor fan to maintain the duct static pressure at a setpoint. In cooling mode, the compressors shall be cycled (or economizer modulated) to maintain the supply air temperature (SAT) at the desired setpoint. In heating mode, the indoor fan shall operate at maximum speed whenever the heater operating. VAV units cannot be controlled by a thermostat.

### Powered or Unpowered Convenience Outlet

This is a GFCI, 120V/15amp, 2 plug, convenience outlet, either powered or unpowered. When the convenience outlet is powered, a service receptacle disconnect will be available. The convenience outlet is powered from the line side of the disconnect or circuit breaker, and therefore will not be affected by the position of the disconnect or circuit breaker. This option can only be ordered when the Through-the-Base Electrical with either the Disconnect Switch or Circuit Breaker option is ordered.

### Single Zone VAV – One Zone Variable Air Volume Mode

Single-zone VAV shall vary the indoor fan speed as the zone cooling or heating load changes, while cooling or heating capacity is cycled to maintain the supply air temperature at setpoint. The indoor fan shall operate at maximum speed whenever the heater is operating.

**Note:** SZVAV requires the use of a zone temperature sensor. If a unit is configured for SZVAV, but is connected to a conventional thermostat, the unit will revert to multiple-speed (two-speed) indoor fan control.

### Multi-Speed Indoor Fan System

Multi-speed indoor fan system is designed for use in applications for meeting the minimum requirement of CA Title 24. This system incorporates a multi-speed fan control to change the speed of the fan to 66% of full airflow based off compressor stages.

### Stainless Steel Drain Pan

This option provides excellent corrosion and oxidation resistance. The drain pan shall be reversible and constructed of 304 stainless steel.

### Stainless Steel Heat Exchanger

The optional stainless steel heat exchanger is constructed of 409 stainless steel. It is resistant to corrosion and oxidation and easy to clean. The high strength to weight ratio allows for high ventilation rates with gas units. It is an excellent option to compliment the dehumidification option as a high outside air ventilation unit. With this option, a 10-year stainless steel heat exchanger warranty is standard.

### Supply, Return, and Plenum Air Smoke Detector

With this option, if smoke is detected, all unit operation will be shut down. Reset will be manual at the unit. In order for the supply air smoke detector or return air smoke detector to properly sense smoke in the supply air stream or the return air stream, the air velocity entering the smoke detector unit must be between 500 - 4000 feet per minute. Equipment covered in this manual will develop an airflow velocity that falls within these limits over the entire airflow range specified in the evaporator fan performance table. Supply and/or Return Smoke Detectors may not be used with the Plenum Smoke Detector.

### Thermal Expansion Valve

Thermal Expansion Valve is standard for all models.

### Through-the-Base Electrical Access

An electrical service entrance shall be provided allowing electrical access for both control and main power connections inside the curb and through-the-base of the unit. Option will allow for field installation of liquid-tight conduit and an external field-installed disconnect switch.

### Through-the-Base Electrical with Circuit Breaker

This option is a thermal magnetic, molded case, HACR Circuit Breaker with provisions for through-the-base electrical connections. The circuit breaker will be installed in a water tight enclosure in the unit with access through a swinging door. Wiring will be provided from the switch to the unit high voltage terminal block. The circuit breaker will provide overcurrent protection, be sized per NEC and cULus guidelines, and be agency recognized by cULus.



## Mechanical Specifications

---

### Through-the-Base Electrical with Disconnect Switch

This 3-pole, molded case, disconnect switch with provisions for through-the-base electrical connections are available. The disconnect switch will be installed in the unit in a water tight enclosure with access through a swinging door. Wiring will be provided from the switch to the unit high voltage terminal block. The switch will be cULus agency recognized.

**Note:** *The disconnect switch will be sized per NEC and cULus guidelines but will not be used in place of unit overcurrent protection.*

### Through-the-Base Gas Piping

The unit includes a standard through-the-base gas provision. This option has all piping necessary including black steel pipe segments, manual gas shut-off valve, elbows, and union. The manual shutoff valve includes a 1/8" NPT pressure tap. This assembly will require minor field labor to install (dual fuel only).

### Trane® Air-Fi® Wireless

Air-Fi® wireless communication shall be factory installed and tested. Air-Fi Wireless conforms to ANSI/ASHRAE Standard 135-2016 (BACnet®/ZigBee®<sup>1</sup>).

### Two-Inch Filters

Two-inch MERV 8 and MERV 13 media filters shall be available on all models. When ordered, units come equipped with a filter removal tool.

## Factory or Field Installed Options

### Clogged Filter/Fan Failure Switch

A dedicated differential pressure switch is available to achieve active fan failure indication and/or clogged filter indication. These indications will be registered with a zone sensor with status indication lights. This option is available for microprocessor controlled units.

### Differential Pressure Switches

These sensors allow individual fan failure and dirty filter indication for microprocessor controlled units. The fan failure switch will disable all unit functions and "flash" the Service LED on the zone sensor. The dirty filter switch will light the Service LED on the zone sensor and will allow continued unit operation.

### Discharge Air Temperature Sensing

This option provides true discharge air temperature sensing in heating models. This option is available for microprocessor controlled units.

### Economizer (Standard)

This accessory shall be available with or without barometric relief. The assembly includes fully modulating 0-100 percent motor and dampers, minimum position setting, preset linkage, wiring harness with plug, spring return actuator and fixed dry bulb control. The barometric relief shall provide a pressure operated damper that shall be gravity closing and shall prohibit entrance of outside air during the equipment "off" cycle. Optional solid state or differential enthalpy control shall be available for either factory or field installation. The economizer arrives in the shipping position and shall be moved to the operating position by the installing contractor.

---

<sup>1</sup> ZigBee is a registered trademark of the ZigBee Alliance.

## Electric Heaters

Electric heat modules shall be available for installation within basic unit. Electric heater elements shall be constructed of heavy-duty nickel chromium elements internally delta connected for 240 volt, wye connected for 480 and 600 V. Staging shall be achieved through ReliaTel™. Each heater package shall have automatically reset high limit control operating through heating element contactors. All heaters shall be individually fused from the factory, where required, and shall meet all NEC and CEC requirements when properly installed. Power assemblies shall provide single-point connection. Electric heat modules shall be cULus listed.

## Frostat™

This option is to be utilized as a safety device. The Frostat™ opens when temperatures on the evaporator coil fall below 10°F. The temperature will need to rise to 50°F before closing. This option should be utilized in low airflow or high outside air applications (cooling only).

## Hail Guards

Hail protection quality coil guards are available for condenser coil protection.

## LonTalk® Communication Interface

This option shall be provided to allow the unit to communicate as a Tracer® LCI-R device or directly with generic LonTalk® Network Building Automation System Controls.

## Low Leak Economizer

This accessory meets low leak requirements for ASHRAE 90.1, IECC, and CA Title 24 standards (4 cfm/ft<sup>2</sup>@1" wg exterior air/return air). This option allows 100% outdoor air supply from 0-100% modulating dampers and is standard with barometric relief. It can be paired with powered exhaust for additional building pressure relief. This option can be paired with or without Fault Detection and Diagnostics (FDD) to meet current mandatory CA Title 24 requirements.

**Note:** Available on downflow units only.

## BACnet® Communication Interface

This option shall be provided to allow the unit to communicate directly with a generic open protocol BACnet® MS/TP Network Building Automation System Controls.

## Reference or Comparative Enthalpy

Reference Enthalpy is used to measure and communicate outdoor humidity. The unit receives and uses this information to provide improved comfort cooling while using the economizer. Comparative Enthalpy measures and communicates humidity for both outdoor and return air conditions, and return air temperature. The unit receives and uses this information to maximize use of economizer cooling, and to provide maximum occupant comfort control. Reference or Comparative Enthalpy option shall be available when a factory or field installed Downflow Economizer is ordered. This option is available on all downflow models.

## Trane® Communication Interface

This option shall be provided to interface ReliaTel™ controlled units with the Trane® Integrated Comfort™ systems.

## Mechanical Specifications

---

### Field Installed Options

#### CO<sub>2</sub> Sensing

The CO<sub>2</sub> sensor shall have the ability to monitor space occupancy levels within the building by measuring the parts per million of CO<sub>2</sub> (Carbon Dioxide) in the air. As the CO<sub>2</sub> levels increase, the outside air damper modulates to meet the CO<sub>2</sub> space ventilation requirements.

Two field installed kits are offered: CO<sub>2</sub> sensor and wiring or CO<sub>2</sub> sensor only. The CO<sub>2</sub> sensor only kit should be ordered with factory installed CO<sub>2</sub> Sensor wiring. Factory installed CO<sub>2</sub> sensor wiring saves set-up time and ensures proper unit connections for the CO<sub>2</sub> sensor.

#### Low Leak Economizer

This accessory meets low leak requirements for ASHRAE 90.1, IECC, and CA Title 24 standards (4 cfm/ft<sup>2</sup>@1" wg exterior air/return air). This option allows 100% outdoor air supply from 0-100% modulating dampers and is standard with barometric relief. It can be paired with powered exhaust for additional building pressure relief.

*Note: Available on downflow units only.*

#### Manual Outside Air Damper

This rain hood and screen shall provide up to 50 percent outside air.

#### Motorized Outside Air Damper

Manually set outdoor air dampers shall provide up to 50 percent outside air. Once set, outdoor air dampers shall open to set position when indoor fan starts. The damper shall close to the full closed position when indoor fan shuts down.

#### Outside Air Measuring/Monitoring Control (Traq Dampers)

- Requires Low Leak Economizer (Factory or Field Installed)
- Includes
  - UC400 Controller
  - Damper Actuator
  - Pressure Sensors

#### Powered Exhaust

The powered exhaust, available for 6 to 10 tons units, shall provide exhaust of return air, when using an economizer, to maintain better building pressurization.

#### Programmable Night Setback

Auto or manual changeover with seven-day programming. Keyboard selection of Heat, Cool, Fan, Auto, or On. All programmable sensors have System On, Heat, Cool, Service LED/indicators as standard. Night Setback Sensors have one (1) Occupied, one (1) Un-occupied, and one (1) Override program per day.

#### Remote Potentiometer

The minimum position setting of the economizer shall be adjusted with this accessory.

#### Roof Curb

The roof curb shall be designed to mate with the unit's downflow supply and return and provide support and a water tight installation when installed properly. The roof curb design shall allow field-fabricated rectangular supply/return ductwork to be connected directly to the curb. Curb shall be shipped knocked down for field assembly and shall include wood nailer strips.

### **Thermostat**

Two stage heating and cooling operation or one stage heating and cooling shall be available in either manual or automatic changeover. Automatic programmable electronic with night set back shall also be available.

### **Ventilation Override Accessory**

With the Ventilation Override Accessory installed, the unit can be set to transition up to 3 different pre-programmed sequences for Smoke Purge, Pressurization, and Exhaust. The transition occurs when a binary input on the RTOM is closed (shorted). This would typically be a hard wired relay output from a smoke detector or fire control panel. The ventilation override accessory shall be available as field installed.

### **Zone Sensor**

This control shall be provided to interface with the Micro equipped units and shall be available in either manual, automatic programmable with night setback, with system malfunction lights, or remote sensor options.



The AHRI Certified mark indicates Trane U.S. Inc. participation in the AHRI Certification program. For verification of individual certified products, go to [ahridirectory.org](http://ahridirectory.org).

Trane - by Trane Technologies (NYSE: TT), a global climate innovator - creates comfortable, energy efficient indoor environments for commercial and residential applications. For more information, please visit [trane.com](http://trane.com) or [tranetechnologies.com](http://tranetechnologies.com).

Trane has a policy of continuous product and product data improvement and reserves the right to change design and specifications without notice. We are committed to using environmentally conscious print practices.