



SERVICE PARTS

BULLETIN NO.
54-46-8690

SPECIFY CATALOG NO. AND SERIAL NO. WHEN ORDERING PARTS		REVISED BULLETIN	DATE
Leveling Tripod Pipe Stand with 6" Chain Vise			Sept. 2022
CATALOG NO.	48-22-8690	SERIAL NUMBER	M11A
WIRING INSTRUCTION			

EXAMPLE:
Component Parts (Small #) Are Included
When Ordering The Assembly (Large #).

**SEE PAGE TWO FOR THE
EXPLODED VIEW ILLUSTRATION
OF THE STAND.**

**SEE PAGE THREE FOR THE
SERVICE BOM AND PART
DESCRIPTIONS.**

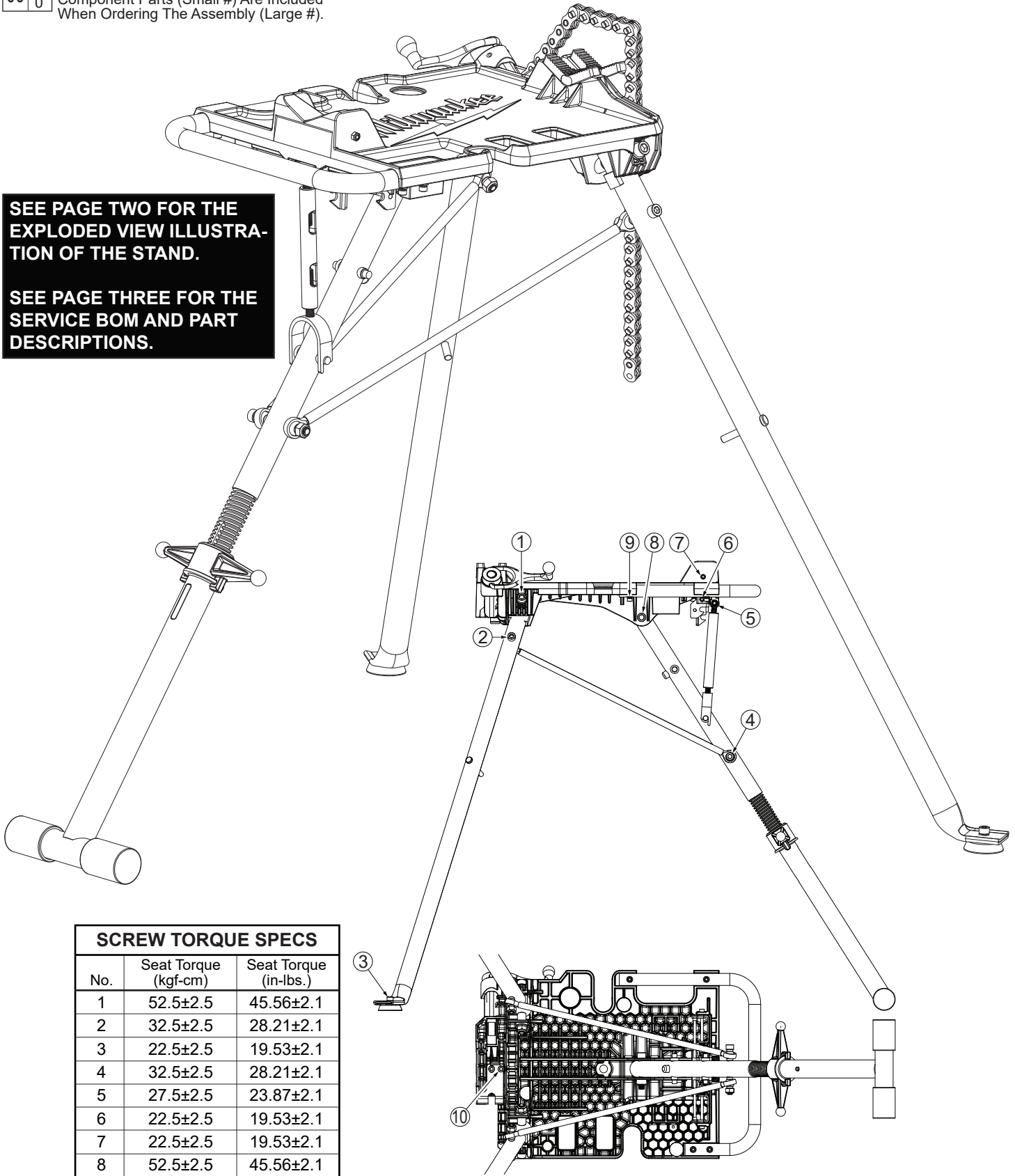

SCREW TORQUE SPECS		
No.	Seat Torque (kgf-cm)	Seat Torque (in-lbs.)
1	52.5±2.5	45.56±2.1
2	32.5±2.5	28.21±2.1
3	22.5±2.5	19.53±2.1
4	32.5±2.5	28.21±2.1
5	27.5±2.5	23.87±2.1
6	22.5±2.5	19.53±2.1
7	22.5±2.5	19.53±2.1
8	52.5±2.5	45.56±2.1
9	22.5±2.5	19.53±2.1
10	27.5±2.5	23.87±2.1

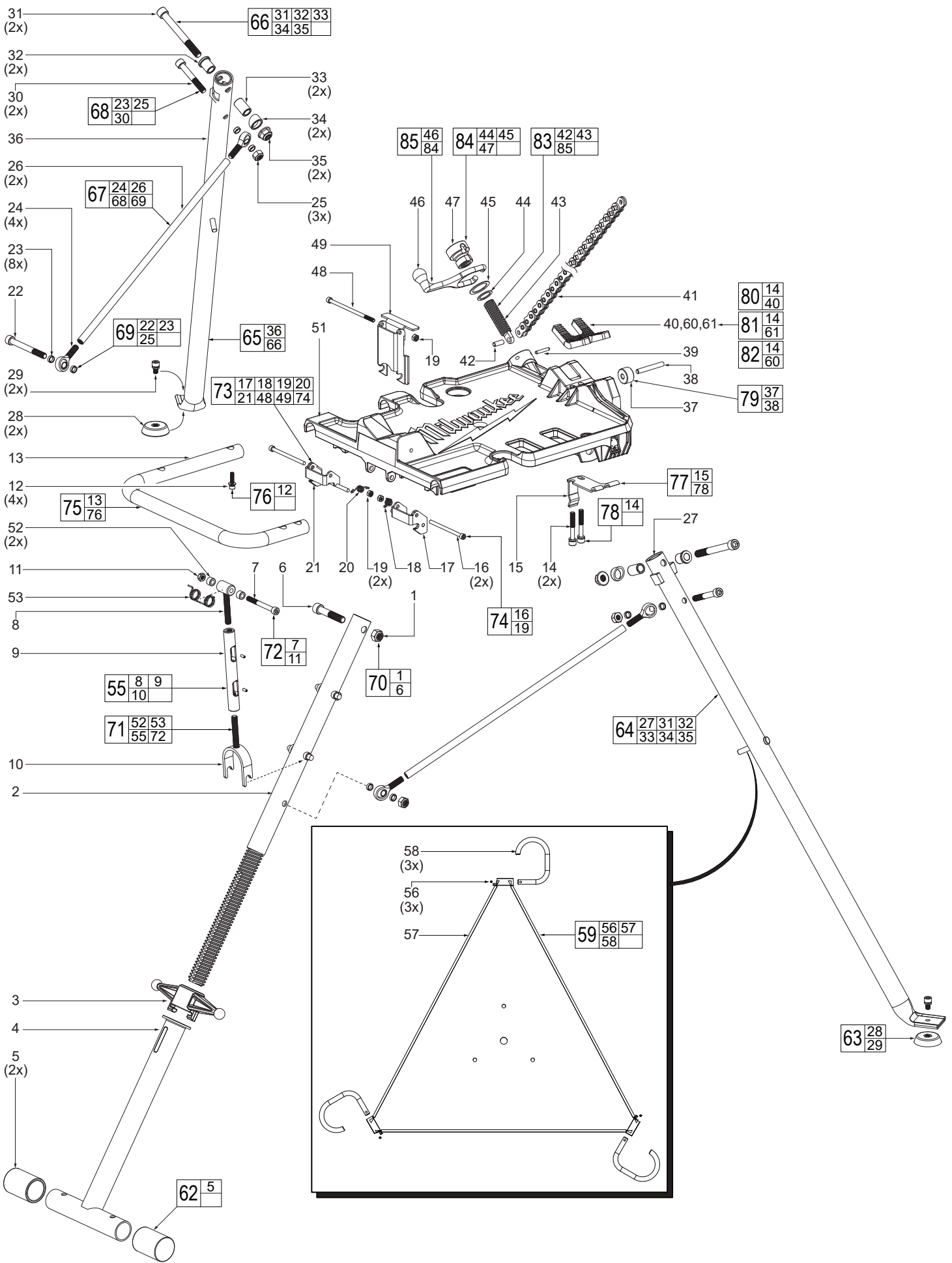

FIG.	PART NO.	DESCRIPTION OF PART	NO. REQ.
1	-----	M12 x 1.75mm Nylon Insert Locknut	(1)
2	-----	Upper Rear Leg Weldment	(1)
3	-----	Lever Adjuster	(1)
4	-----	Lower Rear Leg Weldment, T-Bar	(1)
5	-----	Rear Leg Rubber Slip On Foot	(2)
6	-----	M12 x 1.75 x 65mm Socket Hd. Cap Screw	(1)
7	-----	M8 x 1.25 x 75mm Socket Hd. Cap Screw	(1)
8	-----	Turnbuckle Weldment	(1)
9	-----	Turnbuckle Spreader	(1)
10	-----	Turnbuckle Lower Tread Rod/Catcher Weldment	(1)
11	-----	M8 x 1.25mm Nylon Insert Locknut	(1)
12	-----	M6 x 1 x 25mm Cap Hd. Screw with Washers	(4)
13	-----	Rear Handle Bar	(1)
14	-----	M8 x 1.25 x 55mm Cap Hd. Screw with Washers	(2)
15	-----	Chain Catch	(1)
16	-----	M6 x 1 x 90mm Socket Hd. Cap Screw	(2)
17	-----	Hook Assembly-Right Front Leg	(1)
18	40-50-0357	Torsion Spring-Right Hand Wound	(1)
19	-----	M6 1mm Nylon Insert Locknut	(3)
20	40-50-0358	Torsion Spring-Left Hand Wound	(1)
21	-----	Hook Assembly-Left Front Leg	(1)
22	-----	M10 x 1.5 x 95mm Socket Hd. Cap Screw	(1)
23	-----	Spacer	(8)
24	-----	Rod End Bearing-Right Hand Thread	(4)
25	-----	M10 x 1.5mm Nylon Insert Locknut	(3)
26	-----	Connecting Rod	(2)
27	-----	Front Right Leg Assembly	(1)
28	-----	Front Foot	(2)
29	-----	M8 x 1.25 x 14mm Cap Hd. Screw with Washer	(2)
30	-----	M10 x 1.5 x 70mm Socket Hd. Cap Screw	(2)
31	-----	M12 x 1.75 x 110mm Socket Hd. Cap Screw	(2)
32	-----	Front Leg Bushing	(2)
33	-----	Front Leg Block-Inside	(2)
34	-----	Front Leg Block-Outside	(2)
35	-----	M12 x 1.75 Flanged Locknut with Nylon Insert	(2)
36	-----	Front Left Leg Assembly	(1)
37	-----	Vise Chain Roller	(1)
38	-----	Roller Pin	(1)
39	06-65-0052	Solid Dowel Pin	(1)
40	48-22-8698	Cast Iron Vise Jaw, QT 450 (Standard Equip.)	(1)
41	42-60-0077	Chain Assembly	(1)
42	-----	Chain Dowel Pin	(1)
43	-----	TR20 x 4 Vise Handle Screw	(1)
44	-----	Internal Vise Handle Nut Washer	(1)
45	-----	Vise Handle Nut Washer	(1)
46	-----	Vise Handle Short Lever Arm	(1)
47	-----	Vise Handle Nut	(1)
48	-----	M6 x 1 x 125mm Socket Hd. Cap Screw	(1)
49	-----	Fold Latch Assembly	(1)
51	-----	Table Top	(1)
52	-----	Arbor Spacer	(2)
53	40-50-0359	Double Turnbuckle Torsion Spring	(1)
54	44-04-8690	Rear Leg Assembly	(1)
55	-----	Locking Turnbuckle Assembly	(1)
56	-----	Dowel Pin	(3)
57	-----	Lower Shelf Plate	(1)
58	-----	Lower Shelf Hook	(3)
59	48-22-8695	Lower Shelf Assembly (Accessory)	(1)
60	48-22-8696	PVC Coated Vise Jaw (Accessory)	(1)
61	48-22-8697	Stainless Steel Vise Jaw (Accessory)	(1)
62	14-46-8601	Rear Leg Rubber Foot Cap Kit	(1)
63	14-46-8602	Front Feet Rubber Pad Kit	(1)
64	14-46-8603	Right Leg Weldment Kit	(1)
65	14-46-8604	Left Leg Weldment Kit	(1)
66	14-46-8605	Front Leg Attachment Kit	(1)
67	14-46-8606	Con Rod with Hardware Kit	(1)
68	14-46-8607	Con Rod Front Leg Hardware Kit	(1)
69	14-46-8608	Con Rod Rear Leg Hardware Kit	(1)
70	14-46-8609	Rear Leg Attachment Hardware Kit	(1)
71	14-46-8610	Turnbuckle Assembly Kit	(1)
72	14-46-8611	Turnbuckle Hardware kit	(1)
73	14-46-8612	Front Leg Lock with Hardware Kit	(1)
74	14-46-8613	Front Leg Lock Hardware Kit	(1)
75	14-46-8614	Rear Handle and Hardware Kit	(1)

FIG.	PART NO.	DESCRIPTION OF PART	NO. REQ.
76	14-46-8615	Rear Handle Hardware Kit (Set of four)	(1)
77	14-46-8616	Chain Catch with Hardware kit	(1)
78	14-46-8617	Chain Catch Hardware Kit (Set of two)	(1)
79	14-46-8618	Chain Roller and Pin Kit	(1)
80	14-46-8619	Cast Iron Jaw and Hardware Kit	(1)
81	14-46-8620	Stainless Steel Jaw and Hardware Kit	(1)
82	14-46-8621	PVC Coated Jaw and Hardware Kit	(1)
83	14-46-8622	Vise Assembly Kit	(1)
84	14-46-8623	Vise Nut and Washer Kit	(1)
85	14-46-8624	Vise Handle/Nut/Washer Kit	(1)
86	12-20-8690	Service Nameplate Kit	(1)
87	10-20-6061	Warning Label 1	(1)
88	10-20-6062	Warning Label 2	(1)
89	10-20-6063	Warning Label 3	(2)

