

AIR AND WATER PRESSURE GAUGE

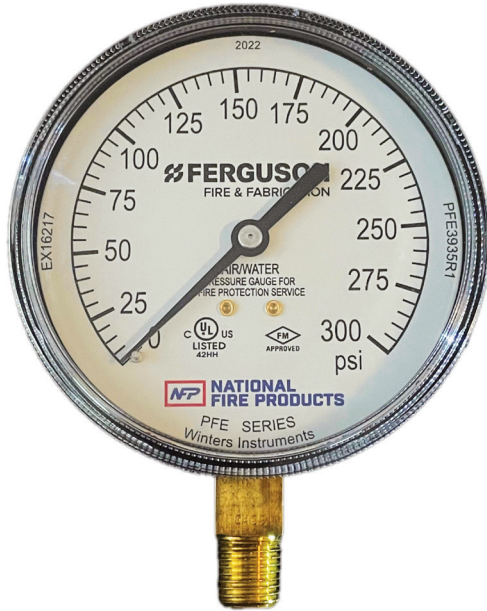

Figure 1501



NFP150104

FEATURES & BENEFITS

- Specially designed for fire sprinkler systems
- Suitable for air and all fluid media that will not obstruct the connection port or corrode alloy parts
- 0–300 psi
- 1/4" NPT connection, bottom
- Window: Screw-on clear polycarbonate

TECHNICAL DATA

- Ambient/Process temperature limits: -40°F to 150°F (-40°C to 65°C)
- Welding: Silvery alloy
- Working pressure: Maximum 75% of full scale value
- UL listed and FM approved

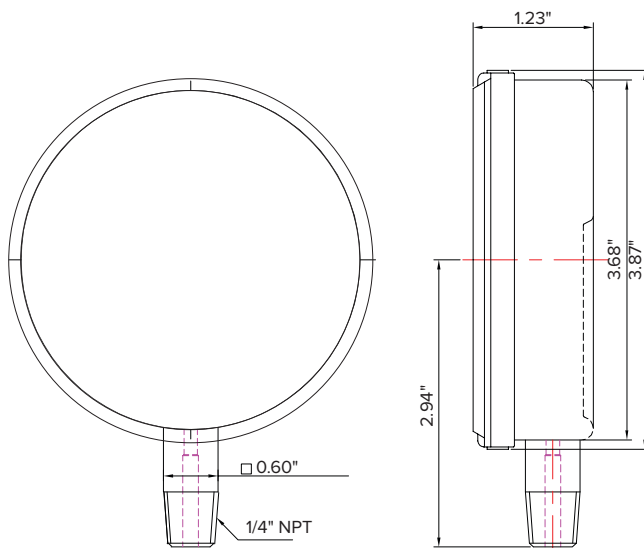

MATERIAL CHART

PART NAME	MATERIAL
Case	Keyuan L870 PBT-TC (Black Plastic)
Dial	Galvalume steel (Aluminum-zinc alloy coated)
Lens	Polycarbonate
Tube	Phosphor Bronze
Socket	Brass
Welding	Silver Alloy



Not approved for potable water applications