



# SUPERstor<sup>®</sup> **ULTRA** MAX

## Indirect Fired Water Heaters

**Installation**

**Start-Up**

**Maintenance**

**Parts**

**Warranty**

**For Residential and Commercial Use**

**MSSU-N\* Models**

**\*Models with an "A" Suffix have an Anode Rod**

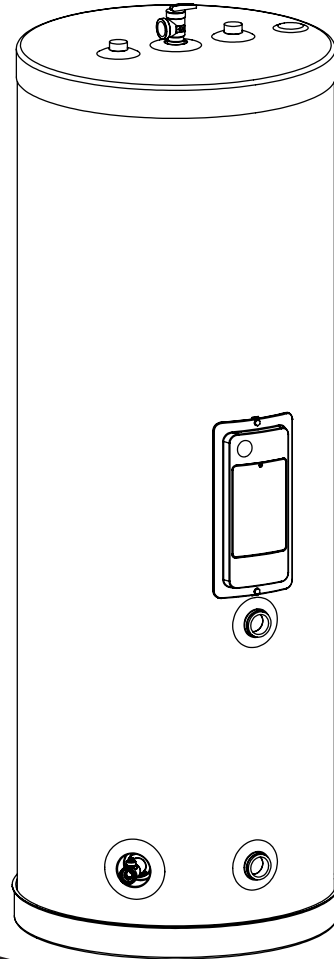

### **WARNING**

This manual must only be used by a qualified installer / service technician. Read all instructions in this manual before installing. Perform steps in the given order. Failure to do so could result in substantial property damage, severe personal injury, or death.

California Proposition 65 Warning: This product contains chemicals known to the State of California to cause cancer, birth defects, or other reproductive harm.

### **NOTICE**

The manufacturer reserves the right to make product changes or updates without notice and will not be held liable for typographical errors in literature.

The surfaces of these products contacted by potable (consumable) water contain less than 0.25% lead by weight as required by the Safe Drinking Water Act, Section 1417.

**NOTE TO CONSUMER: PLEASE KEEP ALL INSTRUCTIONS FOR FUTURE REFERENCE.**

## SPECIAL ATTENTION BOXES

The following defined terms are used throughout this manual to bring attention to the presence of hazards of various risk levels or to important product information.

### DANGER

**DANGER** indicates an imminently hazardous situation which, if not avoided, will result in serious personal injury or death.

### WARNING

**WARNING** indicates a potentially hazardous situation which, if not avoided, could result in personal injury or death.

### CAUTION

**CAUTION** indicates a potentially hazardous situation which, if not avoided, may result in moderate or minor personal injury.

### CAUTION

**CAUTION used without the safety alert symbol** indicates a potentially hazardous situation which, if not avoided, may result in property damage.

### NOTICE

**NOTICE** is used to address practices not related to personal injury.

## Foreword

This manual is intended to be used in conjunction with other literature provided with the water heater. This includes all related control information. It is important that this manual, all other documents included in this system, and additional publications be reviewed in their entirety before beginning any work.

Installation should be made in accordance with the regulations of the Authority Having Jurisdiction, local code authorities, and utility companies which pertain to this type of water heating equipment.

Authority Having Jurisdiction (AHJ) – The AHJ may be a federal, state, local government, or individual such as a fire chief, fire marshal, chief of a fire prevention bureau, labor department or health department, building official or electrical inspector, or others having statutory authority. In some circumstances, the property owner or his/her agent assumes the role, and at government installations, the commanding officer or departmental official may be the AHJ.

**NOTE:** The manufacturer reserves the right to modify product technical specifications and components without prior notice.

## For the Installer

This water heater must be installed by qualified and licensed personnel. The installer should be guided by the instructions furnished with the water heater, and by local codes and utility company requirements.

### Installations Must Comply With:

Local, state, provincial, and national codes, laws, regulations, and ordinances.

## Table of Contents

<b>Part 1 - General Safety Information</b>	<b>3</b>
A. When Servicing the Water Heating System	3
B. Heater Water	3
C. Freeze Protection	3
D. Water Temperature Adjustment	3
<b>Part 2 - Prepare the Water Heater</b>	<b>4</b>
A. Locating the Water Heater	4
B. Water Chemistry Requirements	5
C. Anode Rod	5
D. Technical Specifications	6
E. Optional Equipment	9
<b>Part 3 - Piping</b>	<b>10</b>
A. Plumbing	10
B. Boiler Connections	10
C. Domestic Piping Inlet	10
D. Temperature and Pressure Relief Valve	10
E. Scalding	11
F. Potable Expansion Tank	11
G. Pressure Drop Sizing For Circulator	11
H. Applications	12
<b>Part 4 - Heater Control and Wiring</b>	<b>14</b>
A. Control	14
B. Wiring	15
C. Wiring Diagrams	15
<b>Part 5 - Start-Up and Operation</b>	<b>16</b>
<b>Part 6 - Maintenance and Troubleshooting</b>	<b>17</b>
Limited Warranty	20
Notes	22
Customer Installation Record Form	24

### WARNING

#### From the Uniform Plumbing Code 2000 - Section 510 - Protection From Damage

1. All water heaters installed in areas where they may be subjected to mechanical damage shall be suitably guarded against such damage by being installed behind adequate barriers or by being elevated or located out of the normal path of a vehicle using any such garage.
2. The Administrative Authority may require the use of an approved dielectric insulator on the water piping connections of water heaters and related water heating equipment.
3. In seismic zones 3 and 4, water heaters shall be anchored or strapped to resist horizontal displacement due to earthquake motion. Strapping shall be at points within the upper one-third (1/3) and lower one-third (1/3) of its vertical dimensions. At the lower point, a minimum distance of four (4) inches (102 mm) shall be maintained above the controls with the strapping.
6. A water heater supported from the ground shall rest on level concrete or other approved base extending not less than three (3) inches (76 mm) above the adjoining ground level.
7. When a water heater is located in an attic, attic-ceiling assembly, floor-ceiling assembly, or floor-subfloor assembly where damage may result from a leaking water heater, a watertight pan of corrosion resistant materials shall be installed beneath the water heater with a minimum three-quarter (3/4) inch (20 mm) diameter drain to an approved location.

**Part 1 - General Safety Information**

This water heater is approved for indoor installations only and is not intended for use as a pool heater. Clearance to combustible materials: 0" top, bottom, sides, and back. Heater must have room for service: 24" front, 6" top, and 0" back and sides are minimum recommended service clearances. (A combustible door or removable panel is acceptable front clearance.) This water heater has been approved for closet installation and installation on combustible flooring. Do not install directly on carpeting. Install the water heater in a location where temperature and pressure relief valve discharge or a leak will not result in damage to the surrounding area.

 <b>WARNING</b>
<p><b>Installer</b> - Read all instructions in this manual before installing. Perform steps in the given order.</p> <p><b>User</b> - This manual is for use only by a qualified heating installer / service technician. Have this water heater serviced / inspected annually by a qualified service technician.</p> <p><b>FAILURE TO ADHERE TO THESE GUIDELINES CAN RESULT IN SUBSTANTIAL PROPERTY DAMAGE, SEVERE PERSONAL INJURY, OR DEATH.</b></p> <p><b>NOTE:</b> Obey all local codes. Obtain all applicable permits before installing the water heater.</p> <p><b>NOTE:</b> Install all system components and piping in such a manner that does not reduce the performance of any fire rated assembly.</p> <p><b>NOTE:</b> If the water heater is exposed to the following, do not operate. Immediately call a qualified service technician.</p> <ol style="list-style-type: none"> <li>1. Fire</li> <li>2. Damage</li> <li>3. Water</li> </ol> <p>Failure to follow this information could result in property damage, severe personal injury, or death.</p>
<b>NOTICE</b>
<p><b>UNCRATING THE WATER HEATER</b> - Any claims for damage or shortage in shipment must be filed immediately against the transportation company by the consignee.</p>

**A. When Servicing the Water Heating System**

To avoid electric shock, disconnect electrical supply before performing maintenance.

To avoid severe burns, allow water heater and associated equipment to cool before servicing.

**B. Heater Water**

Do not use petroleum-based cleaning or sealing compounds in a water heating system. Gaskets and seals in the system may be damaged. This can result in substantial property damage.

Do not use "homemade cures" or "patent medicines". Damage to the water heater, substantial property damage, and/or serious personal injury may result.

**NOTICE FOR SINGLE-WALL HEAT EXCHANGER MODELS**

**Per the Uniform Plumbing Code:**

Single-wall heat exchangers are permitted if they satisfy all of the following requirements:

The heat exchanger medium is potable water or contains only substances which are recognized as safe by the US Food and Drug Administration (FDA).

The pressure of the heat exchanger medium is maintained less than the normal minimum operating pressure of the potable water system.

The equipment is permanently labeled to indicate that only additives recognized as safe by the FDA shall be used as the heat transfer medium.

Other heat exchanger designs may be permitted where approved by the AHJ.

<b>CAUTION</b>
DO NOT use this indirect water heater in steam applications. Doing so will result in damage to the water heater. Such damages ARE NOT covered by warranty.

**C. Freeze Protection**

**NOTE:** Consider piping and installation when determining heater location. Place the water heater as close to the boiler as possible in a location not prone to freezing.

<b>CAUTION</b>
Failure of the water heater due to freeze related damage IS NOT covered by product warranty.

In water heaters with single wall heat exchangers, the heat transfer fluid must be water or nontoxic food grade glycol, FDA rated "generally recognized as safe" (GRAS) and having a toxicity rating or class of 1, as listed in Clinical Toxicology of Commercial Products, 5th edition. Ensure the system is permanently labeled to indicate any additives used in the heat transfer fluid.

 <b>WARNING</b>
NEVER use any toxic chemical, including automotive, standard glycol antifreeze, or ethylene glycol made for hydronic (non-potable) systems. These chemicals can attack gaskets and seals in water systems, are poisonous if consumed, and can cause personal injury or death.

**D. Water Temperature Adjustment**

If the water heater is going to have a set temperature above 120°F, you must use an ASSE 1017 rated mixing valve to avoid severe burns or death from scalding temperatures.

 <b>WARNING</b>	
Households with small children, disabled, or elderly persons may require a 120°F or lower temperature setting to prevent severe personal injury or death due to scalding.	
Approximate Time / Temperature Relationships in Scalds	
120°F	More than 5 minutes
125°F	1 1/2 to 2 minutes
130°F	About 30 seconds
135°F	About 10 seconds
140°F	Less than 5 seconds
145°F	Less than 3 seconds
150°F	About 1 1/2 seconds
155°F	About 1 second

**Table 1 - Approximate Time / Temperature Relationships in Scalds**

## Part 2 - Prepare the Water Heater

Remove all sides of the shipping crate to allow the heater to be moved into its installation location.

### CAUTION

**COLD WEATHER HANDLING** - If the water heater has been stored in a very cold location (BELOW 0°F) before installation, handle with care until the components come to room temperature. Failure to do so could result in damage to the water heater.

**NOTE:** A drain valve is included with the water heater.

### A. Locating the Water Heater

### CAUTION

High heat sources (generating heat 100°F / 37°C or greater, such as boiler flue pipes, space heaters, etc.) may damage plastic components of the water heater as well as plastic vent pipe materials. Such damages ARE NOT covered by warranty. It is recommended to keep a minimum clearance of 8" from high heat sources. Observe heat source manufacturer instructions, as well as local, state, provincial, and national codes, laws, regulations, and ordinances when installing this water heater and related components near high heat sources.

All water heaters eventually leak. Locate the water heater where any leakage from the relief valve, related piping, tank, or connections will not result in damage to surrounding areas or lower floors of the building. Any water heater should be installed in such a manner that if it should leak the resulting flow of water will not cause damage to the area in which it is installed. National Plumbing codes require a drain pan for any water heater installation. Such a drain pan must have a clearance of at least 1.0" (2.5 cm) greater than any point on the water heater's outer jacket and must be piped to an adequate drain. Leakage damages ARE NOT covered by warranty. Failure to install a drain pan is the sole responsibility of the owner and/or installer. Reference UPC 2000 (Uniform Plumbing Code) Section 510 - Protection from Damage or IPC 200 (International Plumbing code) Section 504 - Safety Devices. Leakage damages ARE NOT covered by warranty.

In addition, water leak detection devices and automatic water shutoff valves are readily available at plumbing supply houses. IT IS HIGHLY RECOMMENDED BY THE MANUFACTURER TO INSTALL WATER LEAK DETECTION DEVICES AND AUTOMATIC SHUTOFF VALVES. FAILURE TO DO SO COULD RESULT IN PROPERTY DAMAGES.

This water heater is certified for indoor use only. DO NOT INSTALL OUTDOORS. Outdoor installations ARE NOT covered by warranty.

Choose a location for the water heater as centralized to the piping system as possible. Also, locate the water heater and domestic water piping where it will not be exposed to freezing temperatures. All piping should be insulated. Additionally, place the water heater so that the drain, controls, and inlets/outlets are easily accessible.

### WARNING

Ensure the location can support the entire filled weight of the water heater. This water heater must be installed upright and level in the vertical position as described in this manual. DO NOT attempt to install this water heater in any other orientation. Failure to follow these instructions will result in improper water heater operation and property damage, severe personal injury, or death.

### ⚠ DANGER

This water heater must not be located near flammable liquids such as gasoline, butane, liquefied propane, adhesives, solvents, paint thinners, etc., as the controls of this water heater could ignite these vapors and cause an explosion resulting in property damage, severe personal injury, or death.

**NOTE:** To save on heating costs and improve energy efficiency keep the distance between the boiler and water heater to a minimum to reduce heat loss from excess piping and keep friction loss at a minimum. Ensure all piping between the boiler and water heater is properly insulated to minimize heat loss.

The water heater may be located some distance from the boiler provided the circulator meets flow requirements through the coil. The greater the distance from the water heater to the boiler the longer the response will be to a call for hot water.

This water heater must be installed vertical on a level surface.

**NOTE:** In the State of California, the water heater must be braced, anchored, or strapped to avoid moving during an earthquake. Contact local utilities for code requirements in your area. Visit <http://www.dsa.dgs.ca.gov> or call 1-916-445-8100 and request instructions.

However, applicable local codes shall govern installation. For residential water heaters of a capacity of greater than 52 gallons, consult the local building jurisdiction for acceptable bracing procedures.

**NOTE:** If you do not provide the minimum clearances shown in Figure 1, it might not be possible to service the water heater without removing it from the space.

**NOTE:** A combustible door or removable panel is acceptable front clearance.

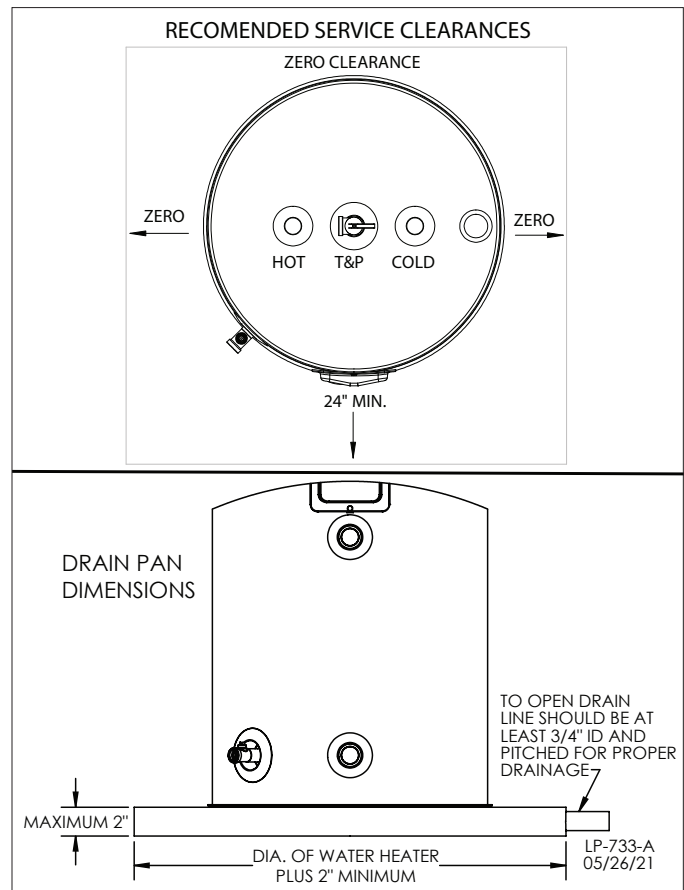

Figure 1 - Drain Pan Installation and Recommended Service Clearances

## B. Water Chemistry Requirements

### CAUTION

Chemical imbalance of the water supply may affect efficiency and cause severe damage to the water heater and associated equipment. Water quality must be professionally analyzed to determine whether it is necessary to treat the water. Various solutions are available to adjust water quality. Adverse water quality will affect the reliability of the system. In addition, operating temperatures above 135°F will accelerate the build-up of lime scale and possibly shorten water heater service life. Failure of a water heater due to lime scale build-up, low pH, or other chemical imbalance IS NOT covered by the warranty.

The water must be potable, free of corrosive chemicals, sand, dirt, and other contaminants. It is up to the installer to ensure the water does not contain corrosive chemicals or elements that can damage the heat exchanger. Potable water is defined as drinkable water supplied from utility or well water in compliance with EPA secondary maximum contaminant levels (40 CFR Part 143.3). If the water contains contaminants higher than outlined by the EPA, water treatment is recommended and additional, more frequent maintenance may be required.

If you suspect that your water is contaminated in any way, discontinue use of the water heater and contact an authorized technician or licensed professional.

- **Water pH between 6.5 and 8.5**
  - pH levels below 6.5 can cause an increase in the rate of corrosion. pH of 8.5 or higher can potentially cause lime scale build-up
  - Maintain water pH between 6.5 and 8.5. Check with litmus paper or have it chemically analyzed by a local water treatment company.
  - If the pH is not between 6.5 and 8.5, consult a local water treatment company for solutions.
- **Hardness less than 12 grains (200 mg/L) (Residential Use - water temperatures below 140°F)**
- **Hardness less than 7 grains (120 mg/L) (Commercial Use - water temperatures of 140°F and greater)**
  - Hardness levels above the required amounts can lead to lime scale build-up throughout the system. Water below 5 grains/gallon (85 mg/L) may be over softened.
  - Consult local water treatment companies for unusually hard water areas (above the required amounts) or for other treatment solutions if water is being over softened (below 5 grains/gallon [85 mg/L]).
- **Chloride concentration less than 100 ppm (mg/L)**
  - Do not fill water heater or operate with water containing chlorides in excess of 100 ppm (mg/L).
  - Using chlorinated fresh water should be acceptable as levels are typically less than 5 ppm (mg/L).
  - Do not connect the water heater to directly heat swimming pool or spa water.
- **Total Dissolved Solids (TDS) less than 500 ppm (mg/L)**
  - Total dissolved solids are minerals, salts, metals, and charged particles that are dissolved in water.
  - The greater the amounts of TDS present, the higher the corrosion potential due to increased conductivity in the water.
  - If using softened water to fill the water heater, it is still possible to have high TDS. This water can be corrosive. Consult local water treatment companies for other treatment solutions to reduce this affect.

**\*NOTE:** To promote water heater service life, it is strongly recommended to follow the maintenance procedures in this manual.

## C. Anode Rod

This water heater may be equipped with an anode rod. Anode rods are sacrificial components that counteract water chemistry to minimize or eliminate tank corrosion.

The anode rod should be inspected annually and replaced as necessary to prolong tank life. Have the supply water quality professionally analyzed, as local water conditions will influence the duration for inspection and replacement of the anode rod.

The use of a water softener may increase the speed of anode consumption. More frequent inspection of the anode is needed when using softened or treated water.

Water with high sulfate and/or mineral content can produce a rotten egg odor in heated water. Consult a water treatment specialist for potential remedies.

**NOTE:** Failure of a heat exchanger due to lime scale build-up on the heating surface, low pH, or other imbalance IS NOT covered by the warranty.

**NOTE:** Do not remove the anode rod from an operating water heater. Operating the water heater without the anode rod will shorten the life of the tank and VOID the warranty.

### CAUTION

Hydrogen gas is produced in a hot water system served by this heater that has not been used for a long period of time (two [2] weeks or more). Hydrogen gas is extremely flammable. To reduce the risk of injury under these conditions, it is recommended that the hot water faucet be opened for several minutes at the kitchen sink before using any electrical appliance connected to the hot water system. When hydrogen is present, there will probably be an unusual sound such as air escaping through the pipe as the water begins to flow. There should be no smoking or open flame near the faucet at the time it is open.

D. Technical Specifications

**SUPERSTOR ULTRA MAX SERIES**

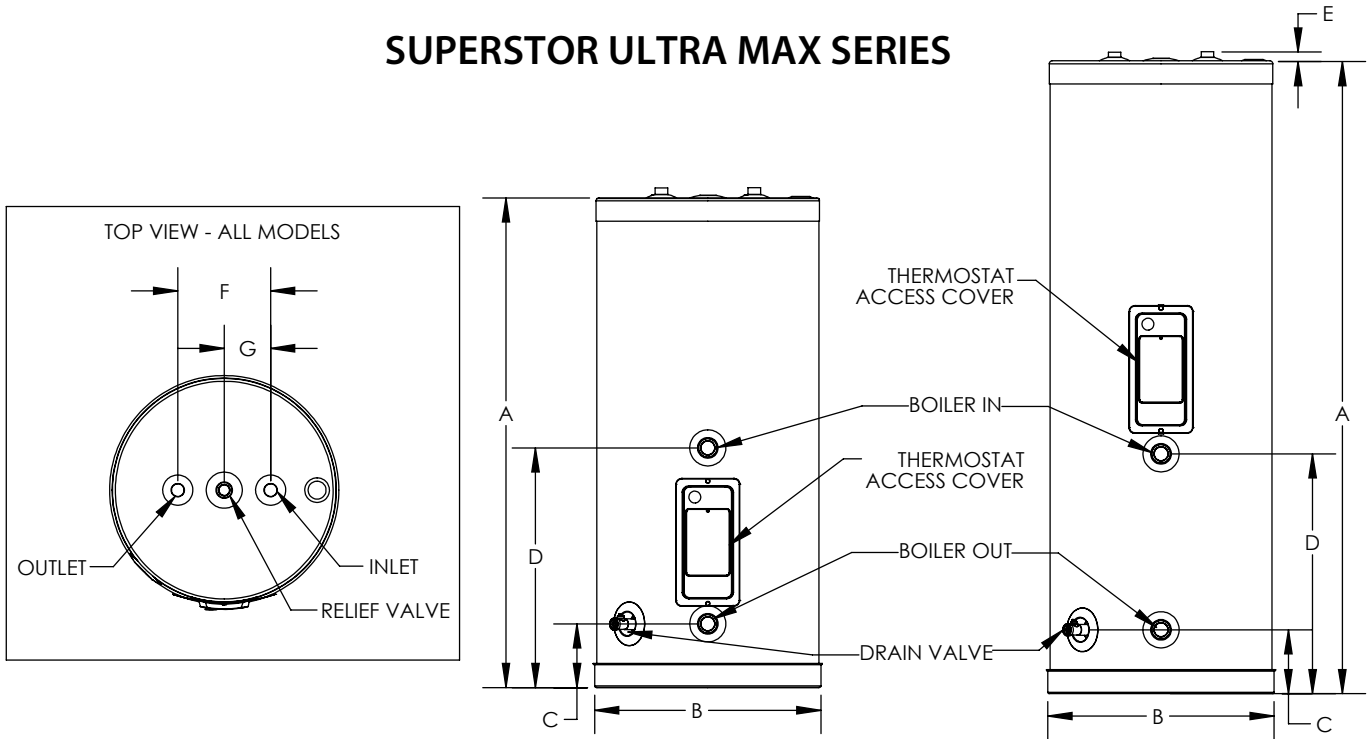

LP-733-B  
05/26/21

**MSSU-30N**

**MSSU-45N/60N/80N/119N**

Model*	A	B	C	D	E	F	G	Domestic Ports	Boiler In/Out	Capacity US Gallons	Weight
MSSU-30N	42-1/8"	19-3/8"	5-7/8"	21"	1-3/8"	8"	4"	3/4" NPT Male	1" NPT Female	28	58 lbs
MSSU-45N	54-1/4"							38		70 lbs	
MSSU-60N	52-5/8"	23-1/2"	8-1/8"	20-1/4"	1-3/8"	8"	4"	1" NPT Male		58	105 lbs
MSSU-80N	69"							78		135 lbs	
MSSU-119N	69"	27-1/2"	8-1/8"	20-1/4"	1-3/8"	8"	4"	1-1/2" NPT Male		115	190 lbs
Model	Heat Exchanger Surface	Test Pressure	Working Pressure	180° F Boiler Water 1st Hour Rating <sup>+</sup>	180° F Boiler Btuh / Size	Recommended Flow Rate	Pressure Drop at Recommended Flow Rate				
MSSU-30N	15 Sq. Ft.	300 PSI	150 PSI	286 Gal.	170,000	14 GPM	5.4 Ft				
MSSU-45N				317 Gal.	185,000						
MSSU-60N				340 Gal.	185,000						
MSSU-80N	18 Sq. Ft.	300 PSI	150 PSI	405 Gal.	215,000	14 GPM	2.0 Ft				
MSSU-119N				433 Gal.	215,000						

Figure 2 - Specifications, Dimensions, and Performance - <sup>+</sup>AHRI TEST METHOD BASED ON 77° F TEMPERATURE RISE, 58° F / 135° F W/BOILER WATER AT 180° F - \*Models with an "A" Suffix are Equipped with an Anode Rod

65° F and 90° F Rise*					
Model	65° F Delta	90° F Delta	180° F Boiler Btuh / Size	Recommended Flow Rate	Pressure Drop at Recommended Flow Rate
MSSU-30N	372	296	170,000	14 GPM	5.4 Ft
MSSU-45N	383	318	185,000		
MSSU-60N	402	343	185,000		
MSSU-80N	486	403	215,000		2.0 Ft
MSSU-119N	503	420	215,000		

\*TEST METHOD WHERE DHW INLET = 50°F and OUTLET = 115 / 140°F (DELTA of 65 / 90°F RESPECTIVELY) W/BOILER WATER AT 180°F

Reduced Flow Performance				
Model	180° F Boiler Water 1st Hour Rating**	180° F Boiler Btuh / Size	Recommended Flow Rate (GPM)	Pressure Drop at Recommended Flow Rate (Ft)
MSSU-30N	266 Gal.	170,000	8	1.7
MSSU-45N	285 Gal.	185,000	10	2.8
MSSU-60N	308 Gal.	185,000		
MSSU-80N	384 Gal.	215,000	12	1.5
MSSU-119N	420 Gal.	215,000	14	2.0

\*\*AHRI TEST METHOD WITH REDUCED FLOW RATES BASED ON 77° F TEMPERATURE RISE, 58° F / 135° F W/BOILER WATER AT 180° F

Heat Up Times					
Model	Time (Min)	Starting Temp (F)	Tank Ending Temp (F)	Coil Inlet Temp (F)	Flow through Coil (GPM)
MSSU-30N	9	58	135	180	14
MSSU-45N	11				
MSSU-60N	14				
MSSU-80N	17				
MSSU-119N	22				

Table 2 - Performance Tables

Performance Graphs

NOTE: Graphs are included for sizing reference only.

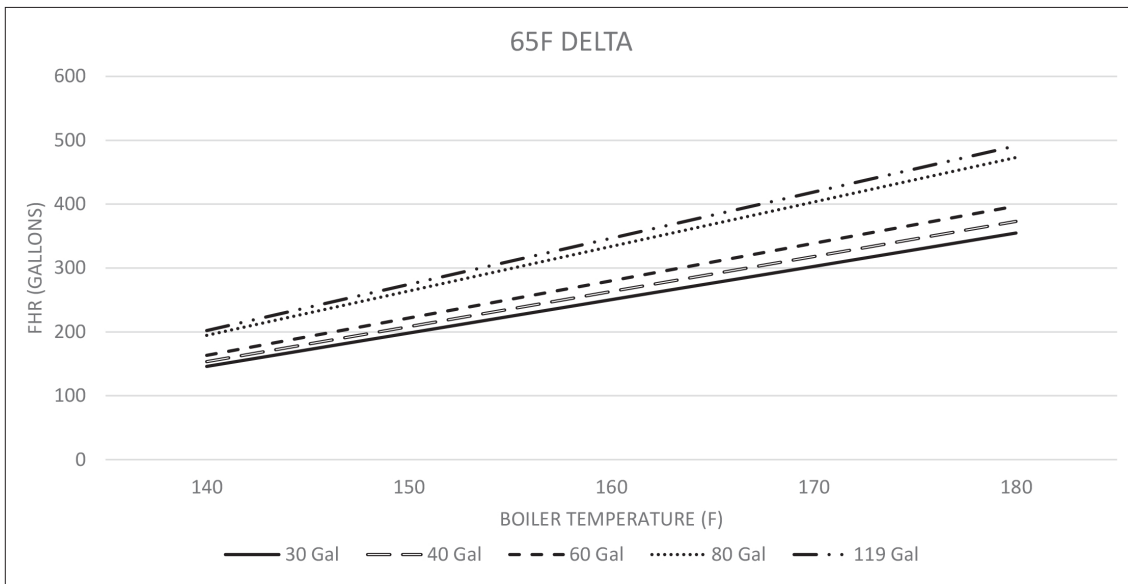

Figure 3 - 65F Delta

\*TEST METHOD WHERE DHW INLET = 50°F and OUTLET = 115 / 140°F (DELTA of 65 / 90°F RESPECTIVELY). BOILER WATER TEMPERATURE VARIED FROM 140°F TO 180°F

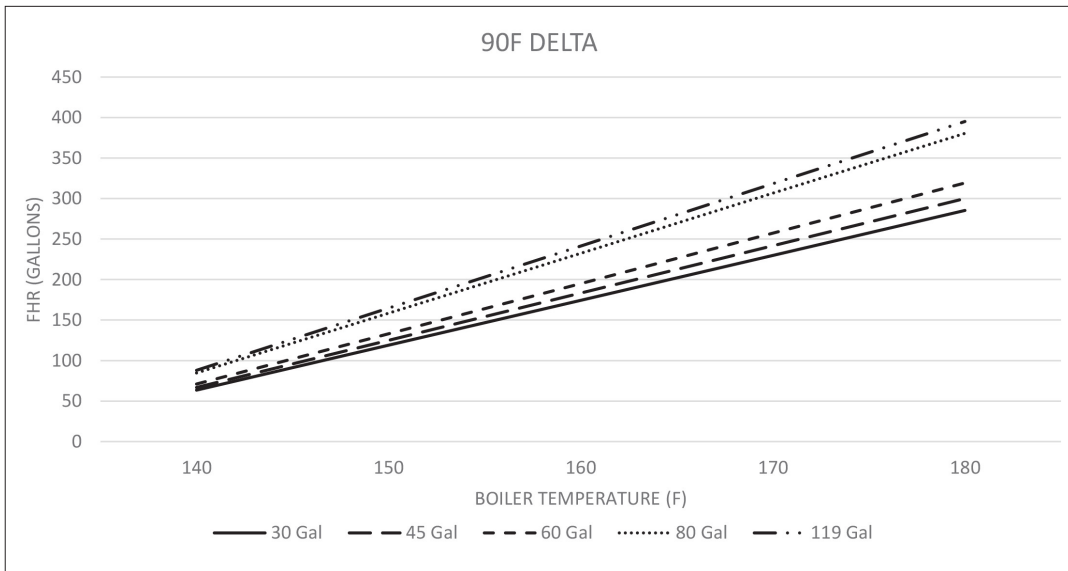

Figure 4 - 90F Delta

\*TEST METHOD WHERE DHW INLET = 50°F and OUTLET = 115 / 140°F (DELTA of 65 / 90°F RESPECTIVELY). BOILER WATER TEMPERATURE VARIED FROM 140°F TO 180°F

\*THE FOLLOWING SETS OF GRAPHS REPRESENTS TEST RESULTS WHERE DHW INLET = 50°F and OUTLET = 115 / 140°F (DELTA of 65 / 90°F RESPECTIVELY). BOILER WATER TEMPERATURE VARIED FROM 140°F TO 180°F

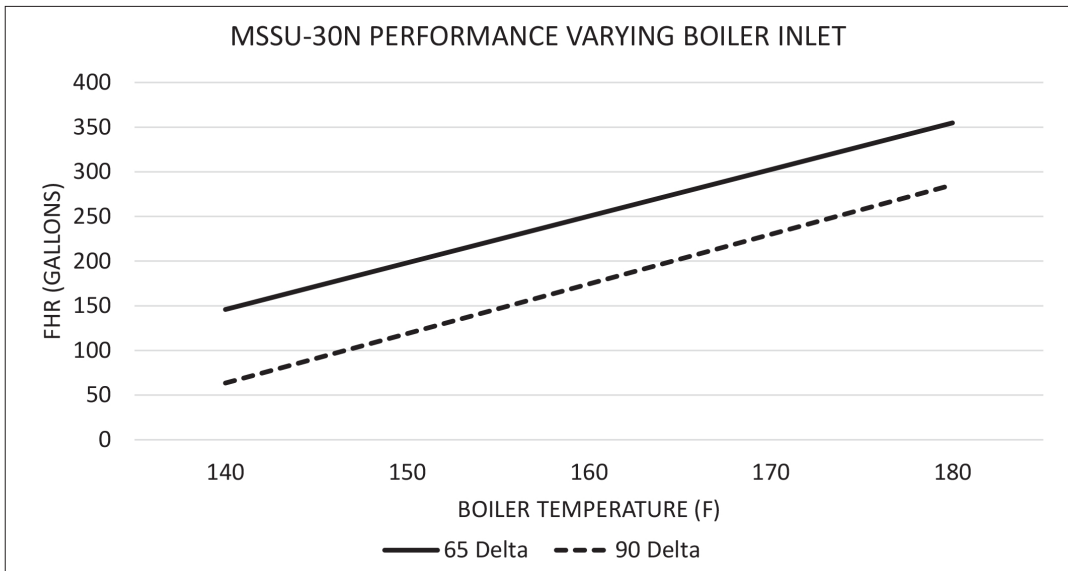

Figure 5 - MSSU-30N Performance with Varying Boiler Inlet

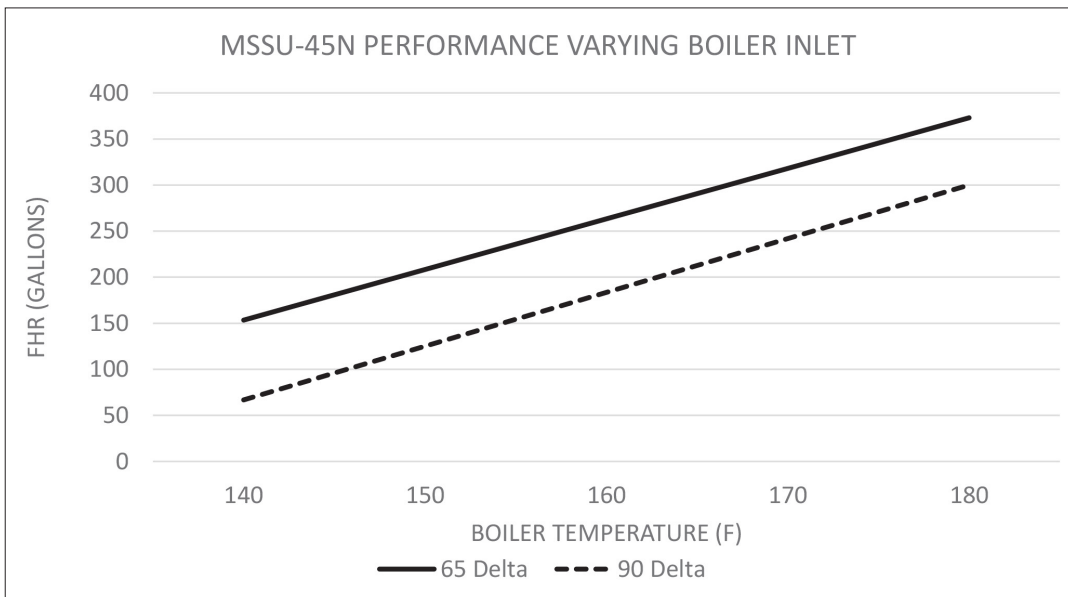

Figure 6 - MSSU-45N Performance with Varying Boiler Inlet



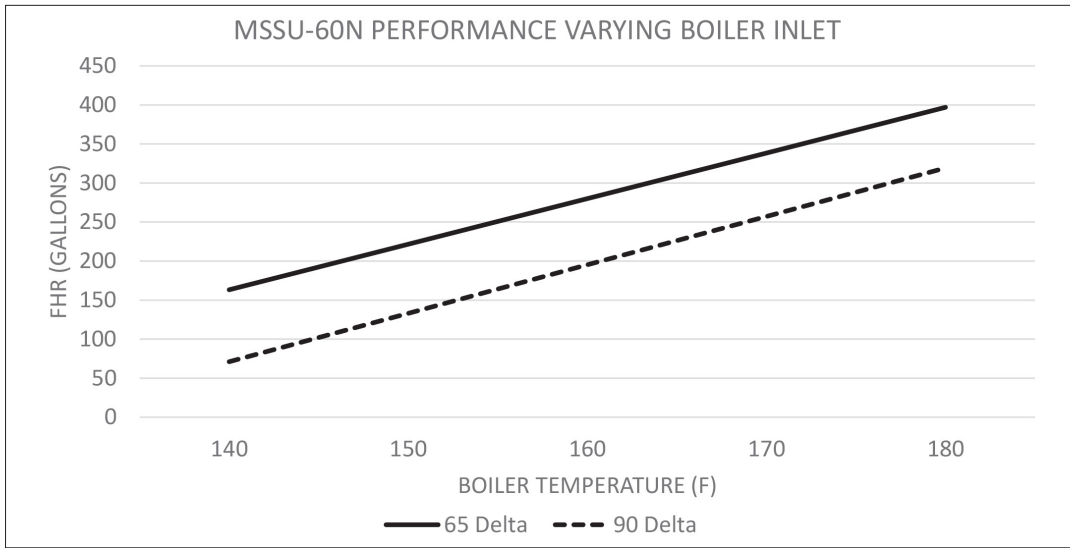

Figure 7 - MSSU-60N Performance with Varying Boiler Inlet

\*THE FOLLOWING SETS OF GRAPHS REPRESENTS TEST RESULTS WHERE DHW INLET = 50°F and OUTLET = 115 / 140°F (DELTA of 65 / 90°F RESPECTIVELY). BOILER WATER TEMPERATURE VARIED FROM 140°F TO 180°F

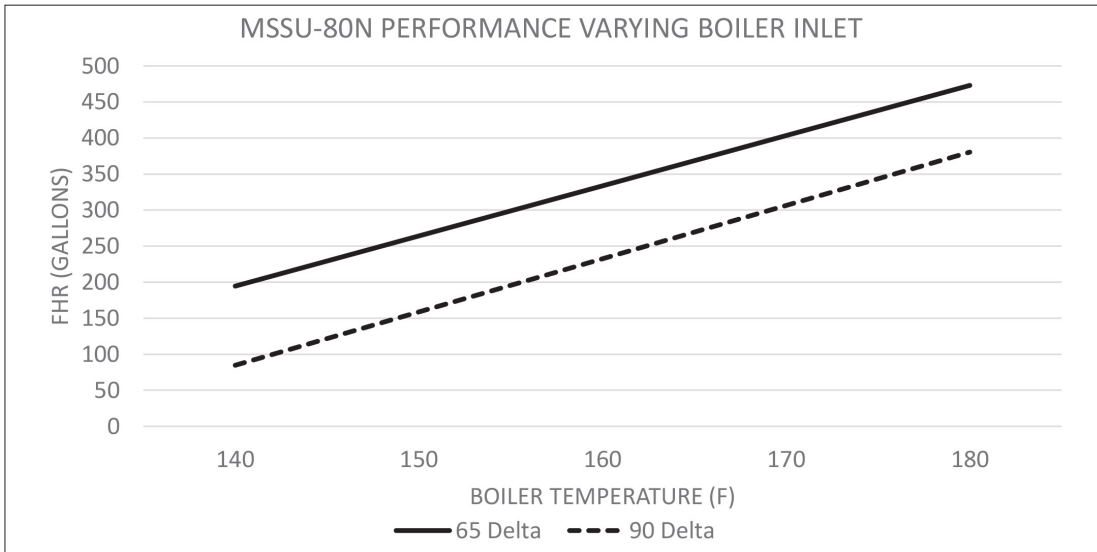

Figure 8 - MSSU-80N Performance with Varying Boiler Inlet

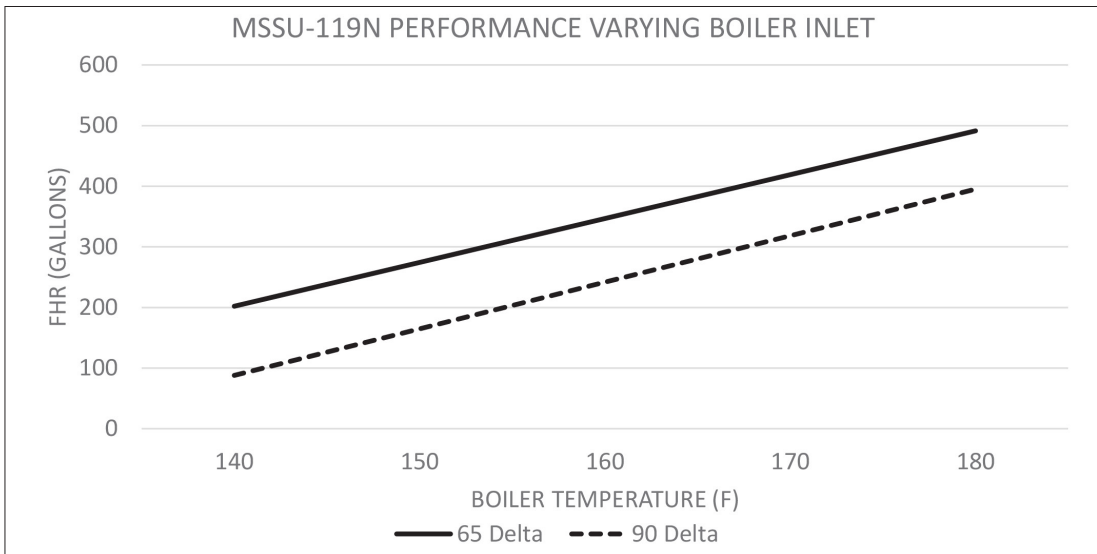

Figure 9 - MSSU-119N Performance with Varying Boiler Inlet

**E. Optional Equipment**

Optional equipment available from HTP (and Part #):

- 10k Sensor (Part # 6070P-990)

## Part 3 - Piping

### A. Plumbing

It is mandatory that all plumbing be done in accordance with federal, local, and state plumbing codes and practices. Failure to properly install the water heater WILL VOID the warranty. It is also necessary to use thread tape or pipe dope on all male mechanical plumbing connections.

#### CAUTION

DO NOT pipe this water heater with black iron, galvanized steel, steel, or lead pipe. Doing so will result in premature product failure and property damage, and WILL VOID the product warranty.

### B. Boiler Connections

#### CAUTION

Use two wrenches when tightening water piping at the heater. Use one wrench to prevent the heater return or supply line from turning. Failure to prevent piping connections from turning could cause damage to water heater components.

DO NOT use this indirect water heater in steam applications. Doing so will result in damage to the water heater. Such damages ARE NOT covered by warranty.

Use a 1" nominal minimum pipe size when piping with zone valves or circulators.

On the water heater, the boiler supply connects to the outlet of the circulator. The circulator inlet is to be connected to the hot outlet side of the boiler. Be sure that the arrow on the circulator is facing the correct flow direction. (See pressure drop sizing for circulator, this manual.)

On the tank, the boiler return connects to the return side of the boiler. The return(s) from heating loop(s) should have a flow check or swing check valve installed before the return pipe from the tank.

### C. Domestic Piping Inlet

#### CAUTION

Never use dielectric fittings or galvanized steel fittings on any domestic water connections. Use only copper or brass fittings. Failure to do so will result in premature water heater failure. Such failure IS NOT covered by warranty.

#### WARNING

Never connect domestic water connections to any system that uses glycol or other solutions formulated for hydronic systems. These connections are to be used only in a potable water system. Failure to follow this warning could result in severe personal injury or death.

Use thread tape or pipe dope to connect male adapters to the all stainless steel 3/4" domestic inlet and outlet. A shut-off valve between the city water supply and tank inlet is recommended for ease of service.

It may be recommended to use a back flow preventer - check local codes. If a back flow preventer or no return valve is used, a thermal expansion tank must be installed on the cold water supply between the tank and valve. If the tank is replacing a tankless coil in the boiler, disconnect coil plumbing and use the cold water inlet and hot water outlet pipes for the water heater.

### D. Temperature and Pressure Relief Valve

On all models, an appropriate temperature and pressure (T&P) valve must be supplied and installed as detailed in the piping diagrams in this installation manual.

Use thread tape or pipe dope to install an NPT brass T&P relief valve for hot water heaters, as required by local codes but not less than valves certified as meeting the requirements for relief valves for hot water heaters (ANSI Z21.22 / CSA 4.4) by a nationally recognized lab that maintains periodic inspection of production listed equipment. Make sure the relief valve is sized to the BTU/Hour capacity of the water heater. The relief line cannot be in contact with any live electrical parts. If the relief valve constantly weeps install an expansion tank. See expansion tank manufacturer's instructions for suggestions.

#### WARNING

To avoid water damage or scalding due to relief valve operation:

- Discharge line must be connected to relief valve outlet and run to a safe place of disposal. Terminate the discharge line in a manner that will prevent possibility of severe burns or property damage should the relief valve discharge.
- Discharge line must be as short as possible and the same size as the valve discharge connection throughout its entire length.
- Discharge line must pitch downward from the valve and terminate at least 6" above the floor drain, making discharge clearly visible.
- The discharge line shall terminate plain, not threaded, with a material serviceable for temperatures of 375°F or greater.
- Do not pipe discharge to any location where freezing could occur.
- No valve may be installed between the relief valve and heater or in the discharge line. Do not plug or place any obstruction in the discharge line.
- Test the operation of the relief valve after filling and pressurizing the system by lifting the lever. Make sure the valve discharges freely. If the valve fails to operate correctly, immediately replace with a new properly rated relief valve.
- Test T&P valve at least once annually to ensure the waterway is clear. If valve does not operate, turn the heater "off" and call a plumber immediately.
- Take care whenever operating relief valve to avoid scalding injury or property damage.

FAILURE TO COMPLY WITH THE ABOVE GUIDELINES COULD RESULT IN FAILURE OF RELIEF VALVE OPERATION, RESULTING IN POSSIBILITY OF EXPLOSION, SUBSTANTIAL PROPERTY DAMAGE, SEVERE PERSONAL INJURY, OR DEATH.

**RE-INSPECTION OF T&P RELIEF VALVES: T&P valves should be inspected AT LEAST ONCE EVERY THREE YEARS, and replaced if necessary,** by a licensed plumbing contractor or qualified service technician to ensure that the product has not been affected by corrosive water conditions and to ensure that the valve and discharge line have not been altered or tampered with illegally. Certain naturally occurring conditions may corrode the valve and its components over time, rendering the valve inoperative. Such conditions can only be detected if the valve and its components are physically removed and inspected. **Do not attempt to conduct an inspection on your own.** Contact your plumbing contractor for a re-inspection to assure continued safety. **FAILURE TO RE-INSPECT THE T&P VALVE AS DIRECTED COULD RESULT IN UNSAFE TEMPERATURE AND/OR PRESSURE BUILD-UP WHICH CAN RESULT IN PROPERTY DAMAGE, SERIOUS PERSONAL INJURY, OR DEATH.**

**E. Scalding**

**WARNING**

An ASSE 1017 or ASSE 1070 temperature limiting or mixing valve is recommended in installations servicing disabled or elderly persons, or children. Mixing valves do not eliminate the risk of scalding.

To avoid scalding:

- Set the water heater set point temperature as low as possible.
- Feel water before bathing or showering.
- If thermostatic valves are required, use devices specifically designed for such purpose. Install these devices in accordance with instructions provided by the manufacturer.

Failure to install a temperature limiting or mixing valve and follow these instructions could result in property damage, severe personal injury, or death due to scalds.

This water heater can deliver scalding water. Be careful whenever using hot water to avoid scalding injury. Certain appliances such as dishwashers and automatic clothes washers may require increased water temperatures. By setting the thermostat on this heater to obtain the increased water temperature required by these appliances you may create the potential for scald injury.

To protect against injury, install a mixing valve in the water system. This valve will reduce point of use discharge temperatures by mixing cold and hot water in branch supply lines. Such valves are available from your local plumbing supplier.

Table 1 details the relationship of water temperature and time with regard to scald injury and may be used as a guide in determining the safest water temperature for your applications.

**F. Potable Expansion Tank**

A potable hot water expansion tank may be required to offset heated water expansion. If there is a back flow preventer or any other type of no return or check valve in the system a thermal expansion tank IS MANDATORY. The expansion tank must be sized for the entire water volume of the hot water system. A weeping relief valve indicates the need for an expansion tank. See the Typical Expansion Tank example in the Piping section for details.

**G. Pressure Drop Sizing For Circulator**

The boiler circulator flow rate must meet the requirements found in the water heater specifications, Part 2, this manual, or the published ratings cannot be achieved. The flow chart represents the pipe run, water heater, and heat exchanger ONLY and does not include any flow checks, zone valves, or friction loss through the boiler. That resistance must be added to the value found in Figure 10.

**DANGER**

**BURN**

Water temperature over 125°F can cause severe burns instantly or death from scalds. Children, disabled and elderly are at highest risk of being scalded. See instruction manual before setting temperature at water heater. Feel water before bathing or showering. Temperature limiting valves are available, see manual.

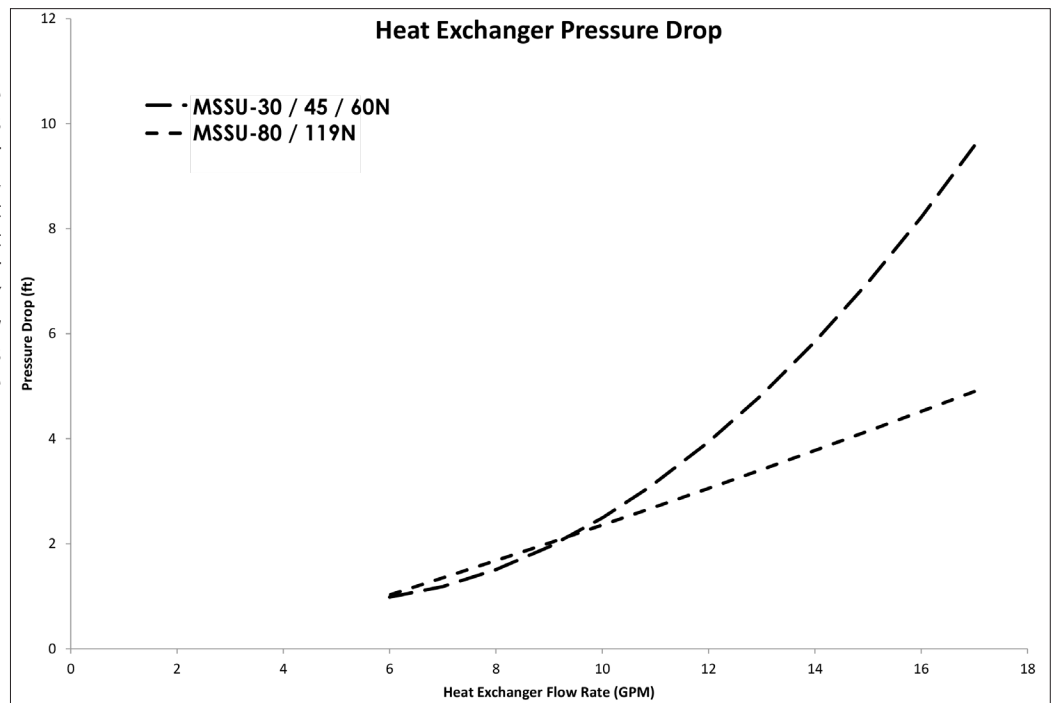
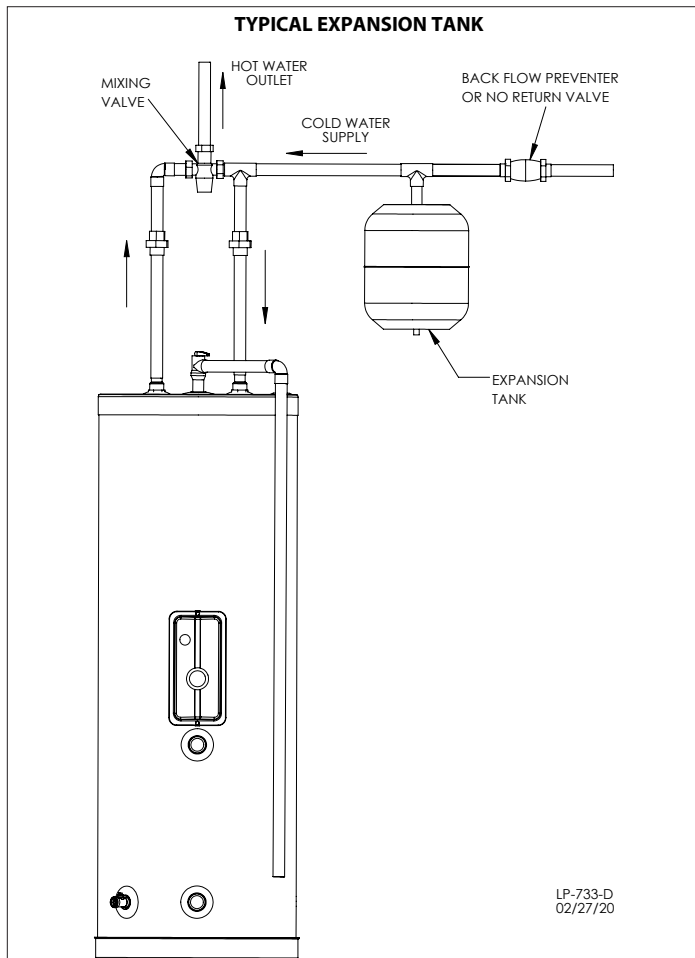

Figure 10 - Pressure Drop through the Heat Exchanger

**H. Applications**

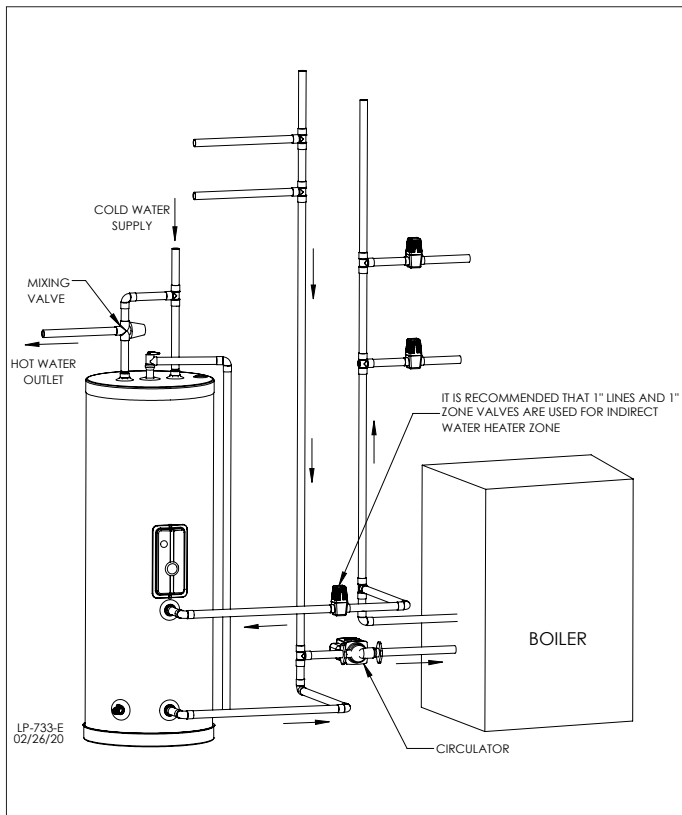

**Figure 11 - Typical Potable Water Side Piping Application, with Expansion Tank**

**PIPING NOTES:**

The following notes are applicable to all of the piping applications demonstrated on this page.

1. Minimum pipe size should match connection size. Upsize pipe accordingly if greater flow is required.
2. A thermal expansion tank suitable for potable water must be sized and installed within this piping system between the backflow preventer and the cold water inlet.
3. All circulators should have an integral flow check.
4. Drains and check valve between unit and water heater will assist in purging air from system.
5. This drawing is meant to demonstrate system piping only. The installer is responsible for all equipment and detailing required by local codes. In Massachusetts, you must install a vacuum relief valve per 248 CMR.
6. Mixing valve application is optional, but recommended to help prevent scalding. See Part 3 for more information.



**Figure 12 - Zoning with Zone Valves**

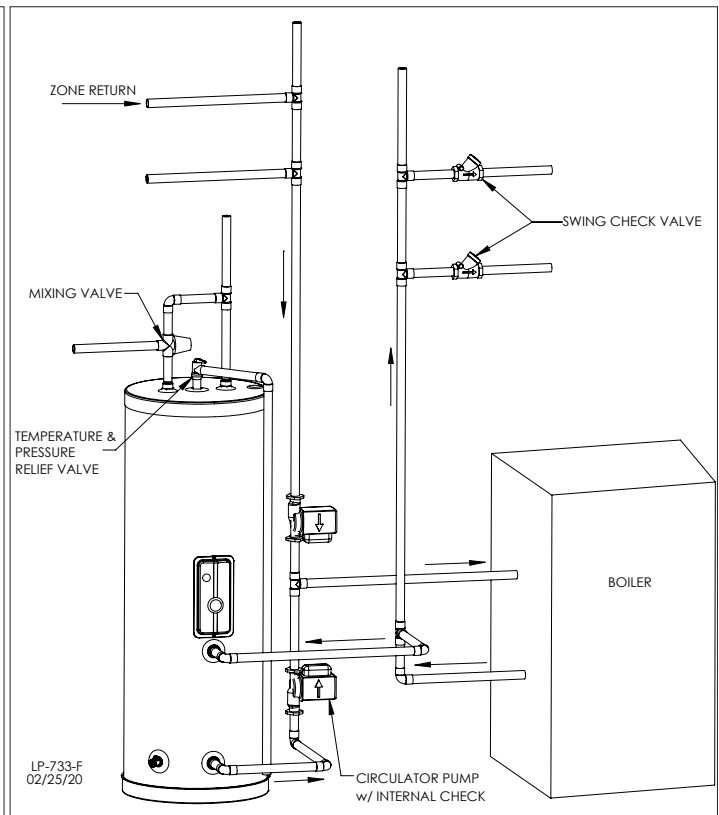

**Figure 13 - Zoning with Circulators**

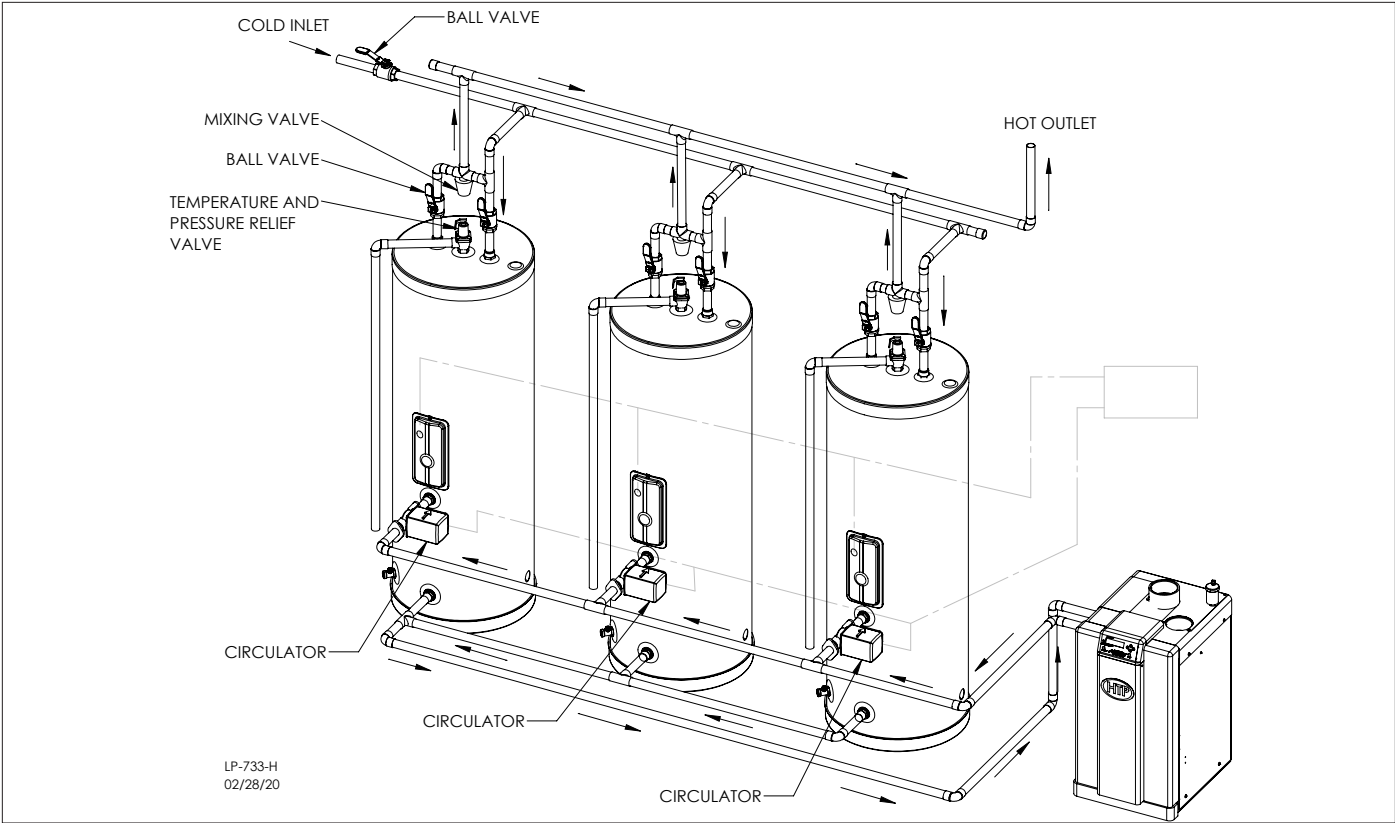

Figure 14 - Zoning with Circulators

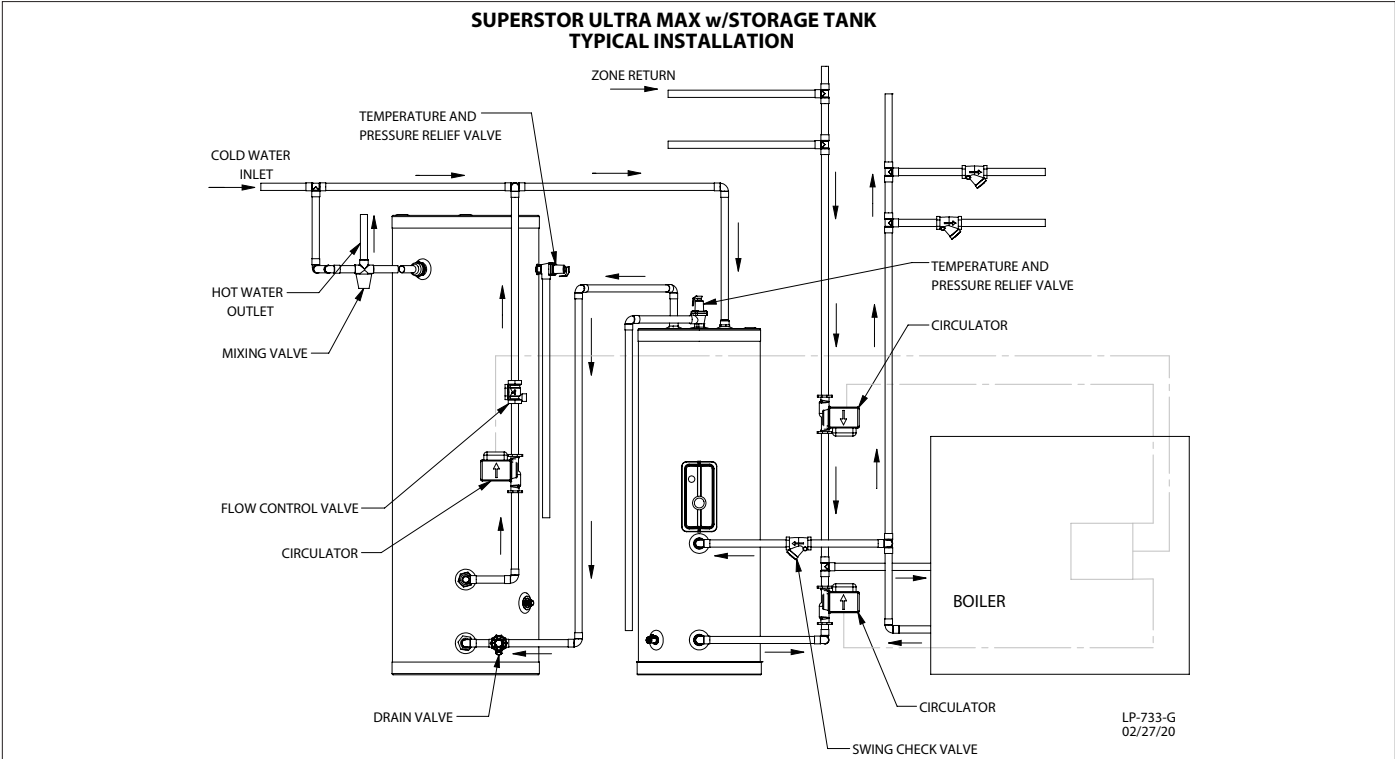

Figure 15 - Zoning with Circulators

**PIPING NOTES:**

- The following notes are applicable to all of the piping applications demonstrated on this page.
1. Minimum pipe size should match connection size. Upsize pipe accordingly if greater flow is required.
  2. A thermal expansion tank suitable for potable water must be sized and installed within this piping system between the backflow preventer and the cold water inlet.
  3. All circulators should have an integral flow check.
  4. Drains and check valve between unit and water heater will assist in purging air from system.
  5. This drawing is meant to demonstrate system piping only. The installer is responsible for all equipment and detailing required by local codes. In Massachusetts, you must install a vacuum relief valve per 248 CMR.
  6. Mixing valve application is optional, but recommended to help prevent scalding. See Part 3 for more information.

**Part 4 - Heater Control and Wiring**

**A. Control**

A surface mount thermostatic control has been provided for accurate temperature adjustment. A removable thermostat cover has been provided to aid in adjusting the thermostat. Remove the cover to adjust the thermostat. Replace the cover after adjustment is complete. See Figure 16.

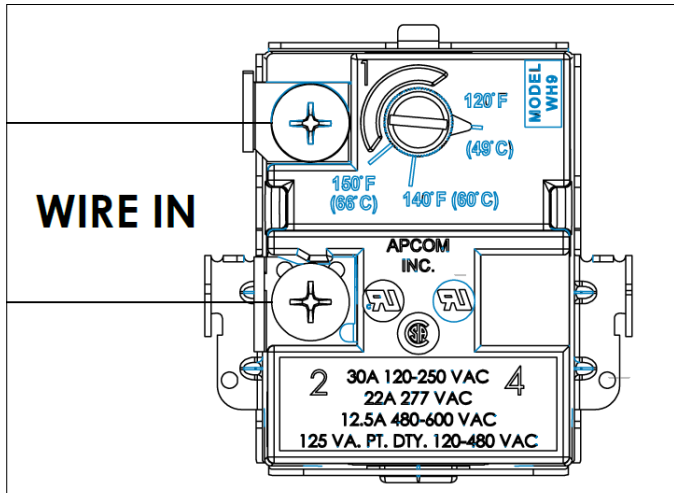

**Figure 16 - Thermostat Connection**

In addition, a sensor clip has been provided with this water heater for the installation of a surface mount sensor. The thermostatic control will have to be removed and replaced with the sensor clip to use a sensor. A 10k sensor is available from HTP - Part # 6070P-990.

**NOTE:** Removed hardware (screws and nuts) will be reused! Replacements are not included in this kit.

To install the sensor clip:

1. Remove the thermostat cover with a #1 Phillips. See Figure 17. The screw will be reused.
2. Use a 7/16" deep socket to remove the two (2) nuts securing the thermostat to the water heater. See Figure 18. The nuts will be reused.



**Figure 17 - Screw Securing the Cover**



**Figure 18 - Nuts Securing the Thermostat**

3. Remove the thermostat bracket and thermostat.
4. Mount the sensor clip (included) using the lower stud and nut. See Figure 19.
5. Remove the 3/4" plug from the access cover. See Figure 20.

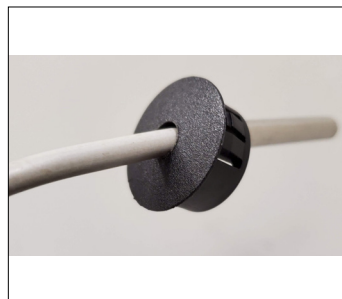

**Figure 19 - Sensor Clip Installed on the Lower Stud**



**Figure 20 - 3/4" Access Cover Plug**

6. Run the surface mount temperature sensor (not included) through the hole in the 3/4" plug. See Figure 21. Options for running sensor through opening:
  - a. Drill a 0.25" hole through the center of the 3/4" plug. See Figure 21.
  - b. Use a field supplied universal open/close bushing for a 0.875" hole (not shown).
  - c. Use a standard field supplied electrical conduit fitting for a 0.875" hole (not shown).



**Figure 21 - Sensor Through the 3/4" Plug**



**Figure 22 - Sensor Clip on the Lower Stud**

7. Place the surface mount temperature sensor between the sensor clip. See Figure 22. Tighten the nut so that the sensor is securely in contact with the tank.
8. Reinstall the cover. See Figure 23.
9. Wire sensor to boiler.



**Figure 23 - Cover Reinstalled**

**B. Wiring**

Wiring is to be done in accordance with all applicable local and state codes. Turn off all power related to the boiler before starting any wiring procedures. It is recommended that a disconnect switch be installed between the boiler control and the water heater.

**CAUTION**

When wiring the water heater and controls be sure to label all wires to ease future maintenance. Wiring errors can cause improper and dangerous operation.

A knockout has been provided on the access panel to ease wiring the thermostat. See Figure 16. Connect the wires from the thermostat to the screw terminals on the surface mounted thermostat on the water heater.

**C. Wiring Diagrams**

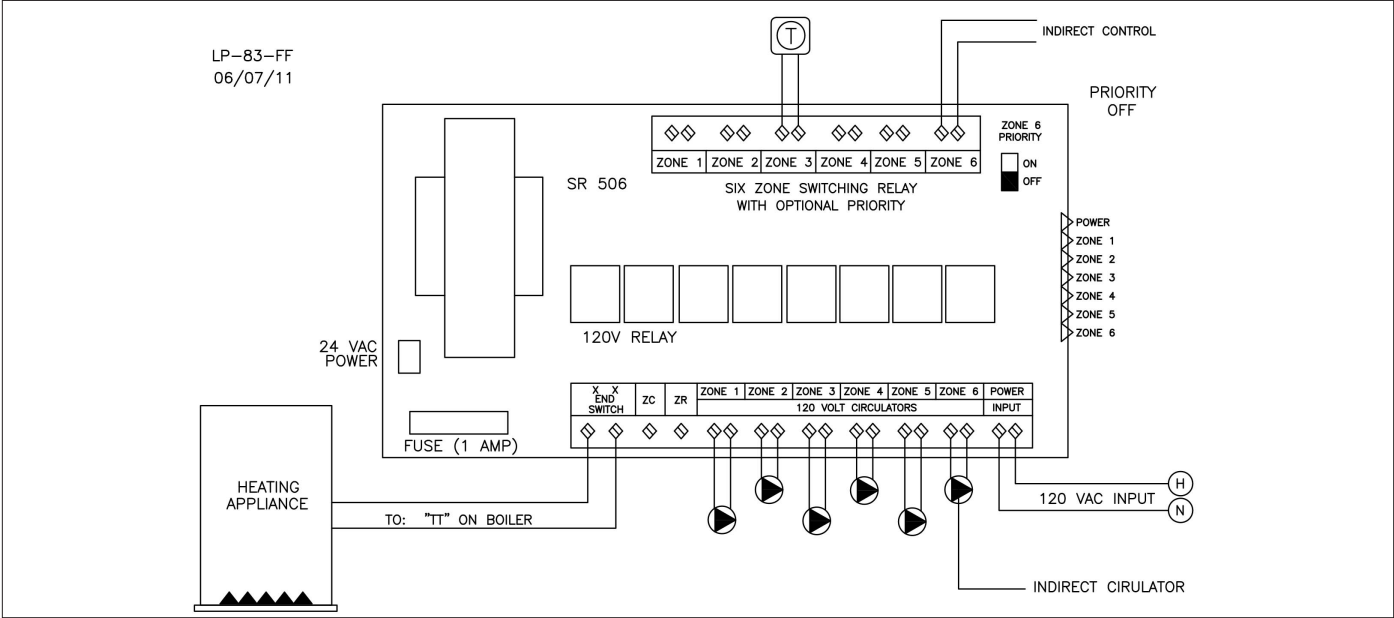

**Figure 24 - Wiring with Circulators**

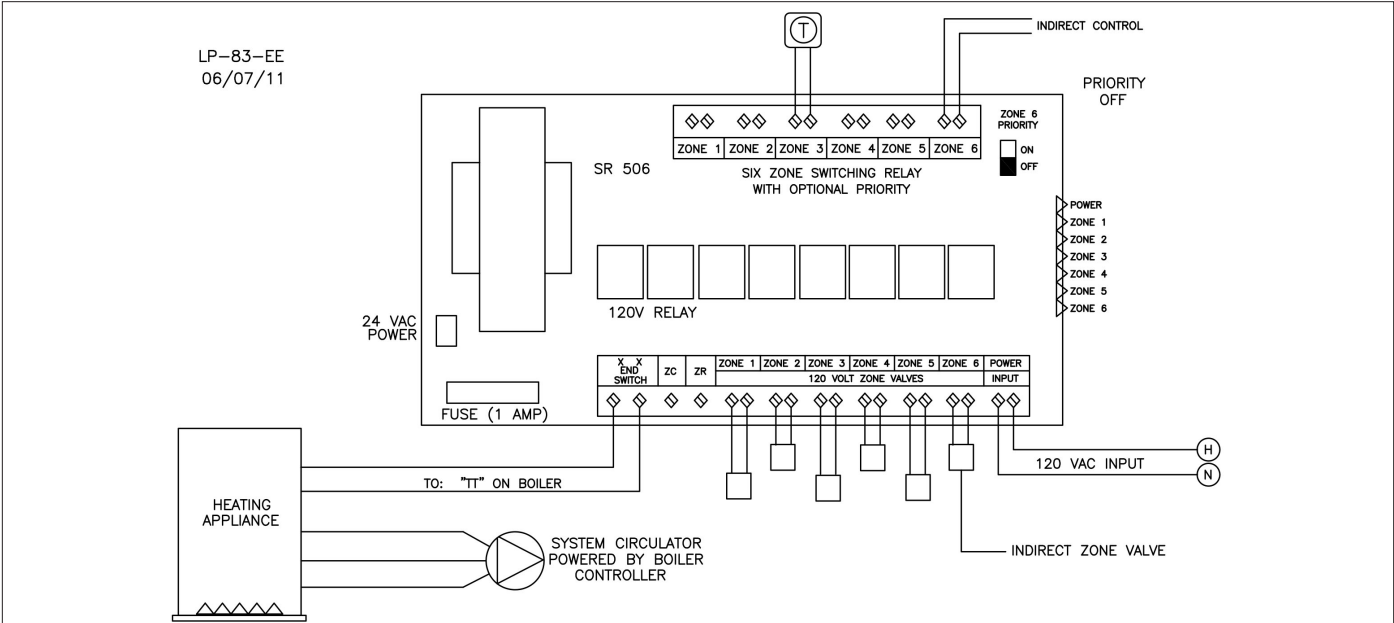

**Figure 25 - Wiring with Zone Valves**

**Part 5 - Start-Up and Operation**

1. Fill the water heater by opening the cold water shut-off valve. Make certain the field installed drain valve is completely closed. Purge air from the system by opening a hot water outlet at a fixture in a kitchen or bathroom. When water flows freely from the outlet, the system is purged.

**CAUTION**

When filling the water heater, open a hot water tap to release air in the tank and piping to ensure proper water heater operation. Failure to ensure the water heater is full before turning on the system will result in damage to the water heater, and could result in property damage. Such damages ARE NOT covered by warranty.

2. Check the system for leaks.

**CAUTION**

Fix any leaks before continuing the installation. Failure to do so could result in property damage or personal injury.

3. After ensuring there are no leaks within the system, flush the system to clear any soldering residue. Many soldering fluxes contain Zinc Chloride, which can corrode stainless steel.

Draw at least three times the volume of the water heater to properly flush the system.

4. Initiate a call for hot water. Ensure each zone valve or circulator operates only when its thermostat calls for heat. Purge each zone of air to ensure proper operation.

5. Set the water heater to the desired temperature. Boiler high limit should be set at least 20°F higher than the heater temperature. Set the low limit of the boiler control at the minimum setting - this will call the burner on only to satisfy the tank control.

DANGER



Water temperature over 125°F can cause severe burns instantly or death from scalds. Children, disabled and elderly are at highest risk of being scalded. See instruction manual before setting temperature at water heater. Feel water before bathing or showering. Temperature limiting valves are available, see manual.

A water heater temperature setting of 120°F is recommended. However, a lower temperature setting may be required to comply with local and state codes for normal operation. The differential should be set at 10 to 15°F. Installation conditions may require a higher or lower temperature setting. A mixing valve in conjunction with a high temperature setting may be used for high demand applications (spas, hot tubs, whirlpools).

6. When the system is completely flushed, purged of air, and the temperature is set, turn on the boiler. Observe operation. Ensure the boiler shuts down after the indirect water heater set point is satisfied.

**WARNING**

Risk of scald injury increases as you increase water temperature.

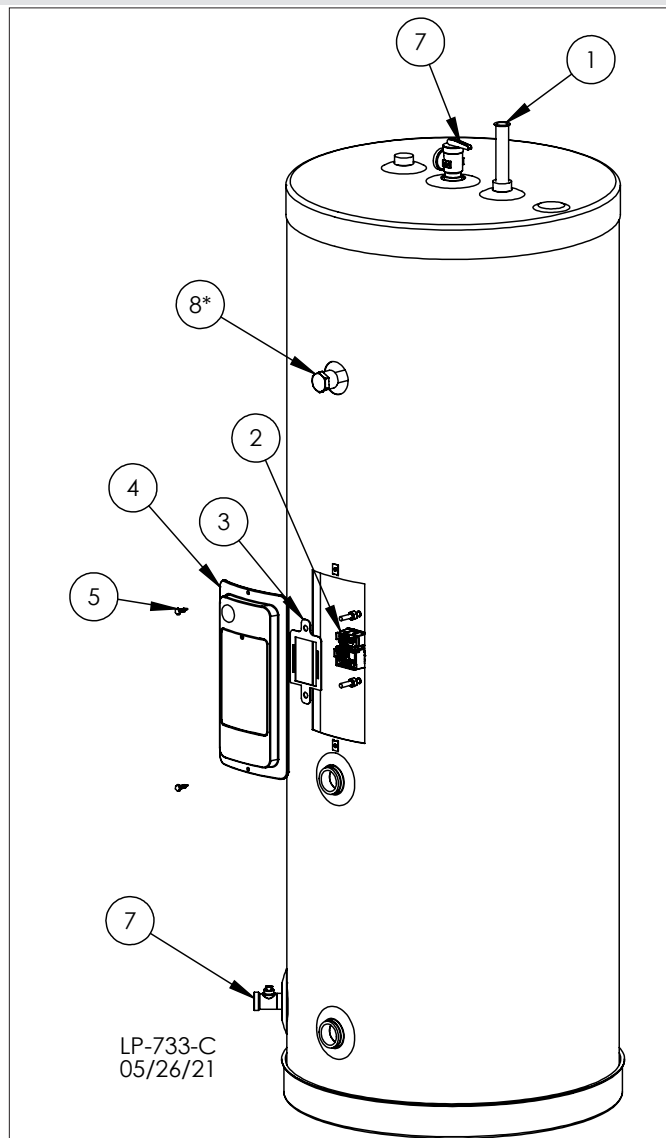

**Figure 26 - Replacement Parts**

Item #	Part #	Description
1	6070P-038	Dip Tube Cold Inlet - 30 Gal
	6070P-139	Dip Tube Cold Inlet - 45 Gal
	6070P-141	Dip Tube Cold Inlet - 60 Gal
	6070P-142	Dip Tube Cold Inlet - 80 and 119 Gal
2	6060P-1009	Thermostat
3	6070P-303	Mounting Clip
4	6070P-108	Electrical Access Panel
5	6075P-006	Screws (#8 Self-Threading)
6	6070P-009	Drain Valve
7	TP1700	Temperature and Pressure Relief Valve (30, 45, 60 Gallon Models)
	TP1400	Temperature and Pressure Relief Valve (80, 119 Gallon Models)
8*	6060P-155	Aluminum Anode 12" Length (1-1/16" Socket)

**Table 3 - Replacement Parts List - \*Applicable to Models with an "A" Suffix ONLY**



## Part 6 - Maintenance and Troubleshooting

### Considerations

- To avoid electric shock, disconnect electrical supply before performing maintenance.
- To avoid severe burns, allow the heater to cool before performing maintenance.

**NOTE:** In addition to the routine maintenance detailed in this manual, this water heater should be inspected annually by a qualified service technician to ensure that all the equipment is operating safely and efficiently. The owner should make necessary arrangements with a qualified heating contractor for periodic maintenance of the heater. The installer must also inform the owner that lack of proper care and maintenance may result in a hazardous condition, premature heater failure, and void the warranty.

Routine preventative maintenance ensures the water heater operates safely and efficiently over its service life. The **Owner / User** may perform the maintenance activities described below.

### Monthly (Every two weeks in hard water locations)

It is recommended that a few quarts of water be drained from the heater. This will flush sediment deposits from the bottom of the heater and lengthen the heater's service life.

### WARNING

Water drained from the water heater may be scalding hot. Take care to avoid scalding. Wear gloves and safety glasses, and direct water to a safe drainage location. It is recommended to turn down the water heater thermostat and run hot water from a faucet until it cools BEFORE draining water from the heater. Failure to comply with this warning could result in property damage, severe personal injury, or death.

To flush the tank, attach a hose to the field installed drain valve. Open the drain valve. Direct the flow of water to a drain or bucket where it will not cause damage.

Flush until water runs clear to complete this operation. Then close the drain valve.

### Periodically (At least twice a year)

Check around the water heater and related plumbing for leaks. If the combination temperature and pressure relief valve discharges periodically, or water is leaking from the water heater, there may be a problem with your water system. **DO NOT ATTEMPT TO REPAIR LEAKS YOURSELF!** Contact a qualified service contractor for assistance.

Check the area around the water heater for flammable liquids or combustible materials. If any are found, remove from the area.

### Vacation (Extended shut-off periods)

During extended mild or warm weather periods when hot water will not be in use, lower the setpoint temperature on the water heater thermostat. When hot water is needed again, raise the setpoint temperature on the water heater thermostat.

Drain the water heating system (as detailed in this section) if the water heater will be shut off and exposed to freezing temperatures. The boiler water may need to be drained as well if it does not contain sufficient antifreeze. Contact a qualified service contractor for assistance.

Fill the water heating system (as detailed in this section) when hot water is needed again. Contact a qualified service contractor for assistance if the boiler water must be filled.

### Draining the Water Heater

**STEP #1** - Turn off power to the water heating system, preferably at the circuit breaker.

### WARNING

Failure to cut power off to the water heating system before draining may result in property damage, severe personal injury, or death due to electric shock.

**STEP #2** - Run hot water at a faucet in the system. When it runs cold, shut off the faucet. Then shut off water at the main cold water inlet or, if possible, valve off the water heater from the system.

**STEP #3** - Open the T&P valve or a hot water tap to prevent vacuum buildup in the tank and piping. Then open the drain valve on the water heater to drain the water from the isolated water heater or water heating system.

**STEP #4** - Close the valve(s) and faucet after the water is drained.

### To Fill the Water Heater and System:

**STEP #1** - Open a hot water tap high in the system to bleed any air pressure. Water will flow freely when air is completely bled.

### WARNING

When filling the water heater, open a hot water tap to release air in the tank and piping. The tank must be full of water before the heater is turned on. Failure to ensure the water heater is full before turning it on will result in damage to the water heater, and could result in property damage, serious personal injury, or death. Such damages ARE NOT covered by water heater warranty.

**STEP #2** - Open the main cold water inlet. If the water heater has been isolated from the system, open the isolation valves. Refill the tank with cold water.

**STEP #3** - Close the tap when air is completely bled from the system and water is flowing freely. Check the water heater and system for leaks.

**STEP #4** - Turn power back on to the domestic water heating system and observe operation. Ensure the water heater is operating properly.

The maintenance activities described below are only to be performed by the **Installer / Qualified Service Provider**. These maintenance items should be performed during recommended **annual** service and any service calls.

1. Ask the owner / user if there have been any issues with the water heater. Diagnose any heater issues and repair / replace parts as necessary.
2. Check the water heater and related plumbing for leaks. Repair any that are found.
3. Check the area around the water heater for flammable liquids or combustible materials. If any are found, remove from the area.
4. "A" Suffix Models - Remove and inspect the anode. Replace if necessary.
5. Inspect the Temperature and Pressure (T&P) Relief Valve. See instructions, this manual.
6. Turn power supply off to the water heater. Open the drain valve and drain a few gallons of water from the tank to clear any hard water deposits. Once complete, close the drain valve and restore power to the water heater.

### To Inspect / Replace the Anode ("A" Suffix Models ONLY):

**STEP #1** - Drain the water heater following the procedure detailed in this section.

### WARNING

Completely drain the water heater before removing the anode. Failure to do so will result in a leakage of water and property damage, and could possibly result in moderate to severe personal injury or death.

**STEP #2** - After the water heater is drained remove the anode rod. Anode rod location and size is detailed in Replacement Parts, this manual.

**STEP #3** - Observe the anode rod. The anode rod should be replaced when more than 6" of core wire is exposed at either end of the rod.

**STEP #4** - Use pipe tape or approved sealant on threads to install the anode rod. Fill the water heater and check for leaks.

Annual Maintenance Activities		Date Last Completed			
Piping		1st Year	2nd Year	3rd Year	4th Year
Near heater piping	Check heater and system piping for any sign of leakage; make sure pipes are properly supported. Ensure a catch pan is installed. If a leak detection device is installed ensure that it operates correctly based on the manufacturer's recommendations.				
<b>System</b>					
Visual	Do a full visual inspection of all system components. Ensure all components (including boilers, water treatment systems, mixing valves, circulators, etc.) are operating properly and have been maintained.				
Functional	Test all functions of the system. Perform any maintenance required by local codes. Verify system pressure is in the safe operating range.				
Temperatures	Check control for temperature accuracy. *Verify safe settings on Mixing Valve (if installed in system).				
<b>Electrical</b>					
Smoke and CO Detectors	*Verify devices are installed and working properly. Change batteries if necessary.				
Circuit Breakers	Check to see that the circuit breaker is clearly labeled. Exercise circuit breaker.				
Connections	Check wire connections. Make sure they are tight.				
<b>Anode Rod - "A" Suffix Models ONLY</b>					
	Remove and visually inspect the anode rod. Anode rod should be replaced when more than 6" of core wire is exposed at either end of the rod.				
<b>Relief and Drain Valve</b>					
Relief Valve	Lift and release the relief valve on the water heater. Make certain that the valve operates properly by allowing several gallons to flush through the discharge line. Replace if valve is blocked or does not operate properly. NOTE: TAKE CAUTION WHEN OPERATING RELIEF VALVE. DISCHARGED WATER MAY PRESENT A SCALD RISK.				
Drain Valve	Open the drain valve and drain a few quarts of water from the bottom of the tank to flush any hard water deposits. Replace if valve is blocked or does not operate properly. NOTE: TAKE CAUTION WHEN OPERATING DRAIN VALVE. DRAINED WATER MAY PRESENT A SCALD RISK.				
<b>Final Inspection</b>					
Check for Combustibles	Check area around heater for combustible materials such as gasoline or paint thinner. If combustible materials are found, move away from the heater to a safe location.				
Checklist	Verify that you have completed the entire checklist. WARNING: FAILURE TO DO SO COULD RESULT IN SERIOUS INJURY OR DEATH.				
Homeowner	Review what you have done with the homeowner.				
<b>Initial and Date after Inspection / Service. Continue Inspections Annually beyond the Fourth Year.</b>					

Table 4 - Maintenance Activities Checklist - \*If Applicable to System

<b>Troubleshooting</b>			
<b>No Hot Water</b>		<b>Not Enough Hot Water</b>	
<b>Problem</b>	<b>Possible Solution</b>	<b>Problem</b>	<b>Possible Solution</b>
Zone valve not opening	Open manually to replace	Zone valve restriction	1" full bore replace zone valve
Circulator not operating	Check or replace	Circulator arrow reversed	Reverse circulator
Tank control set too low	Raise tank temperature*	Tank temperature too low	Raise tank temperature*
Boiler control set too low	Raise boiler temperature	Boiler temperature too low	Raise boiler temperature
Wiring incorrect	Check wiring	Boiler sized too small	Check sizing chart
Tank control failure	Replace control	Tank sized too small	Check sizing chart
Zone valve failure	Replace valve	Demand flow rate too high	Install mixing valve. Raise tank temperature
Circulator failure	Replace circulator	Air trap in loop	Purge air
Air trap in loop	Purge air		Install flow regulator
		Heat and tank come on together	Check wiring or set indirect as priority over heating
			Draw tank down and lower thermostat. Recheck.
		Not enough space heat	Boiler sized too small. Consult chart.
		Slow recovery	Circulator head capacity too low
<b>T&amp;P Valve Discharges</b>		<b>Hot Tubs, Spas, Multiple Showers, High Demand</b>	
<b>Problem</b>	<b>Possible Solution</b>	<b>Problem</b>	<b>Possible Solution</b>
Tank temperature too high	Lower tank temperature	Pressure too low	Check line pressure for restriction
Water expands when heated	Install expansion tank	Tank recovery slow	Slow startup boiler. See chart
Water pressure too high	Install pressure reducing valve	Not enough hot water	Boiler sized too small. See chart
			Check flow rate. Compare to chart
			Demand too great. Check flow rates and compare to chart. Install mixing valve and/or flow restricting valve and raise tank and boiler temperature.*
<b>Hot Water Has Rotten Egg Odor</b>			
<b>Problem</b>	<b>Possible Solution</b>		
Supply water has high sulfate or mineral content	Check with water quality specialist in your area. Have water supply analyzed. Address water quality issues according to specialist's recommendations.		

**Table 5 - Troubleshooting - \*See scald warning below.**

 <b>WARNING</b>
The risk of scald injury increases as you increase water temperature. Use a water tempering or mixing valve and extreme caution when using hot water to avoid scald injury. Consult codes for conformance. Failure to follow the instructions in this warning statement could result in serious personal injury or death from scalds.

<b>CAUTION</b>
If draining of the water heater is necessary, open the T&P valve or a hot water tap to prevent vacuum buildup in the tank and piping.

**SuperStor Ultra MAX  
Indirect Fired Water Heater / Solar Water Heater  
Limited Warranty**

For Residential and Commercial Use

HTP warrants each indirect fired water heater to be free from defects in materials and workmanship according to the following terms, conditions, and time periods. UNLESS OTHERWISE NOTED THESE WARRANTIES COMMENCE ON THE DATE OF INSTALLATION. This limited warranty is only available to the **original consumer purchaser** (hereinafter "Owner") of the water heater, and is non-transferable.

<p><b>Standard Residential Use Warranty (Ten [10] years – Tank, One [1] year – Components)</b></p>
<p>Standard Residential Use shall mean water heaters not registered online with HTP used in a single family dwelling, or usage in a multiple family dwelling, provided that the water heater services only one (1) dwelling in which the Owner resides on a permanent basis and operating temperatures do not exceed 140°F.</p>
<p><b>Extended Residential Use Warranty (Lifetime – Tank, One [1] year – Components)</b></p>
<p>Extended Residential Use coverage shall apply to residential use water heaters registered online with HTP at <a href="http://www.htproducts.com/warranty">www.htproducts.com/warranty</a> within six (6) months of the installation date. See the information provided on the following page of this document for registration details.</p>
<p><b>Standard Commercial Use Warranty (Five [5] years – Tank, One [1] year – Components)</b></p>
<p>Standard Commercial Use shall mean any usage not falling within the definition of a "standard residential use" setting.</p>

**COVERAGE**

- A. During the first year after the original date of installation in the dwelling, HTP warrants that it will repair or replace, at its option, any defective or malfunctioning component of the water heater. Replacement components will be warranted for ninety (90) days.
- B. Should a defect or malfunction result in a leakage of water from the water heater within the above-stated warranty periods due to defective material or workmanship, malfunction, or failure to comply with the above warranty, with such defect or malfunction having been verified by an authorized HTP representative, HTP will replace the defective or malfunctioning water heater with a replacement of the nearest comparable model available at the time of replacement. The replacement water heater will be warranted for the unexpired portion of the applicable warranty period of the original water heater.
- C. In the event of a leakage of water of a replacement water heater due to defective material or workmanship, malfunction, or failure to comply with the above warranty, HTP reserves the right to refund to the Owner the published wholesale price available at the date of manufacture of the original water heater.
- D. If government regulations, industry certification, or similar standards require the replacement water heater or component(s) to have features not found in the defective water heater or component(s), the Owner will be charged the difference in price represented by those required features. If the Owner pays the price difference for those required features and/or to upgrade the size and/or other features available on a new replacement water heater or component(s), the Owner will also receive a complete new limited warranty for that replacement water heater or component(s).
- E. If at the time of a request for service the Owner cannot provide a copy of the original sales receipt or the warranty registration, the warranty period for the water heater shall then be deemed to have commenced thirty (30) days from the date of manufacture of the water heater and NOT the date of installation of the water heater.
- F. This warranty extends only to water heaters utilized in water heating applications that have been properly installed by qualified professionals based upon the manufacturer's installation instructions.
- G. It is expressly agreed between HTP and the Owner that repair,

replacement, or refund are the exclusive remedies of the Owner.

**OWNER RESPONSIBILITIES**

The Owner or Installer must:

1. Have a relief valve bearing the listing marks of the American Society of Mechanical Engineers (ASME) installed with the water heater assembly in accordance with federal, state, and local codes.
2. Have a vacuum relief valve certified to ANSI Z21.22 - Relief Valves for Hot Water Supply Systems installed with the water heater assembly in accordance with federal, state, and local codes and in installations prone to vacuum related damages.
3. Maintain the water heater in accordance with the maintenance procedure listed in the manufacturer's provided instructions. Preventive maintenance can help avoid any unnecessary breakdown of the water heater and keep it running at optimum efficiency.
4. Maintain all related system components in good operating condition.
5. Use the water heater in an open system, or in a closed system with a properly sized and installed thermal expansion tank.
6. Use the water heater at water pressures not exceeding the working pressure shown on the rating label.
7. Keep the water heater free of damaging scale deposits.
8. Make provisions so if the water heater or any component or connection thereto should leak, the resulting flow of water will not cause damage to the area in which it is installed.
9. If applicable, have the anode checked annually. Replace the anode if necessary.

**WARRANTY EXCLUSIONS**

This limited warranty will not cover:

1. Any water heater purchased from an unauthorized dealer.
2. Any water heater not installed by a qualified heating installer/service technician, or installations that do not conform to ANSI, CSA, and/or UL standards, as well as any applicable national or local building codes.
3. Service trips to teach the Owner how to install, use, maintain, or to bring the water heater installation into compliance with local building codes and regulations.
4. The workmanship of any installer. The manufacturer disclaims and does not assume any liability of any nature caused by improper installation, repair, or maintenance.
5. Electricity or fuel costs, or increased or unrealized savings for same, for any reason whatsoever.
6. Any water damage arising, directly or indirectly, from any defect in the water heater or component part(s) or from its use.
7. Any incidental, consequential, special, or contingent damages or expenses arising, directly or indirectly, from any defect in the water heater or the use of the water heater.
8. Failure to locate the water heater in an area where leakage of the tank or water line connections and the relief valve will not result in damage to the area adjacent to the water heater or lower floors of the structure, as well as failure to install the water heater in or with a properly sized drain pan routed to an approved drainage location.
9. Any failed components of the heat system not manufactured by HTP as part of the water heater.
10. Water heaters repaired or altered without the prior written approval of HTP.
11. Damages, malfunctions, or failures resulting from improper installation, or failure to install the water heater in accordance with applicable building codes/ordinances or good plumbing and electrical trade practices; or failure to operate and maintain the water heater in accordance with the manufacturer's provided instructions.
12. Damages, malfunctions, or failures resulting from failure to operate the water heater at pressures not exceeding the working pressure shown on the rating label.
13. Failure to operate the water heater in an open system, or in a closed system with a properly sized and installed thermal expansion tank.
14. Failure or performance problems caused by improper sizing of the water heater, expansion device, or piping.
15. Damages, malfunctions, or failures resulting from vacuum conditions.
16. Damages, malfunctions, or failures caused by operating the water heater with modified, altered, or unapproved components.

17. Damages, malfunctions, or failures caused by abuse, accident, fire, flood, freeze, lightning, electrochemical reaction, acts of God and the like.
18. Failures (leaks) caused by operating the water heater in a corrosive or contaminated atmosphere.
19. Failure of the water heater due to the accumulation of solid materials and lime deposits.
20. Any damage or failure resulting from improper water chemistry. WATER CHEMISTRY REQUIREMENTS (RESIDENTIAL USE) – Water pH between 6.5 and 8.5. Operating temperatures not exceeding 140°F. Hardness less than 12 grains (200 mg/L). Chloride concentration less than 100 ppm (mg/L). TDS less than 500 ppm (mg/L). (COMMERCIAL USE) - Water pH between 6.5 and 8.5. Hardness less than 7 grains (120 mg/L). Chloride concentration less than 100 ppm (mg/L). TDS less than 500 ppm (mg/L).
21. Any damages, malfunctions, or failures resulting from the use of dielectric unions.
22. Production of noise, taste, odors, discoloration, or rusty water.
23. Water heaters replaced for cosmetic reasons.
24. Components of the water heater that are not defective, but must be replaced during the warranty period as a result of reasonable wear and tear.
25. Damages, malfunctions, or failures resulting from the use of any component(s) / attachment(s) not supplied by HTP.
26. "A" Suffix Models ONLY - Damages, malfunctions, or failures resulting from operating the water heater with the anode removed.
27. Water heaters installed outside the fifty states (and the District of Columbia) of the United States of America and Canada.
28. Water heaters moved from the original installation location.
29. Water heaters that have had their rating labels removed.
30. Water heaters used in steam boiler applications.

#### **ONLINE EXTENDED RESIDENTIAL USE LIMITED WARRANTY REGISTRATION**

To register for the Extended Limited Warranty, complete the form located on the HTP website at <http://www.htproducts.com/warranty> within six (6) months of installation. The form must be completed in full with owner name, email address, and phone number, the address where the unit is installed and installation date, and unit model and serial numbers. Proof of purchase is required, and may be an invoice for the product, or a bill from an installing contractor that clearly documents the installation of the unit. To be valid, proof of purchase must also include the unit serial number. Proof of purchase may be typed or hand written. Submit the proof of purchase to HTP via the directions provided on the website.

#### **PROCEDURES FOR WARRANTY SERVICE REQUESTS**

Any claim for warranty assistance must be made immediately upon finding the issue. First, please consult the HTP Warranty Wizard (<http://www.htproducts.com/Warranty-Wizard.html>) to check warranty eligibility. You may also contact HTP Technical Support at 1-800-323-9651 for questions or assistance. Warranty coverage requires review and approval of the issue with HTP Technical Support or through the Warranty Wizard prior to a full unit replacement. Any claim for warranty reimbursement will be rejected if prior approval from HTP is not obtained in advance of a full unit replacement. Final determination will be made as part of the warranty claim process.

**When submitting a warranty claim the following items are required:**

- 1. Proof of purchase or installation of the product** – Typically a copy of the invoice from the installing contractor, the receipt of the purchase of the product, or an original certificate of occupancy for a new home.
- 2. Clear pictures (or video) of the following:**
  - a. Serial number tag (sticker)
  - b. The product
  - c. The product issue / failure whenever possible
  - d. A picture of the piping near the product
  - e. For gas fired products, a picture of the venting, including how it exits the building

All claims will be reviewed by HTP within three (3) business days. If additional information is required and requested by the HTP Claims Department you will have thirty (30) days to provide it. When all requested information is provided HTP will respond within three (3) business days.

The claim will be automatically closed if requested information is not provided within thirty (30) days. Claims will not be reopened without HTP Warranty Supervisor approval.

During the claims process a product that must be replaced will be given a designation of either a) field scrap, or b) return to HTP. If the product must be returned to HTP, the returned product must arrive at HTP within thirty (30) days of the date of our request to return the product. After receipt of the returned product HTP may require as many as thirty (30) additional days for product testing. **NOTE: Any components or heaters returned to HTP for warranty analysis will become the property of HTP and will not be returned, even if credit is denied.**

If you have questions about the coverage of this warranty, please contact HTP at the following address or phone number: HTP, 272 Duchaine Blvd., New Bedford, MA, 02745, Attention: Warranty Service Department, 1(800) 323-9651.

#### **SERVICE, LABOR, AND SHIPPING COSTS**

Except when specifically prohibited by the applicable state law, the Owner, and not the Manufacturer, shall be liable for and shall pay for all charges for labor or other expenses incurred in the removal, repair, or replacement of the water heater or any component part(s) claimed to be defective or any expense incurred to remedy any defect in the product. Such charges include, but are not necessarily limited to:

1. All freight, shipping, handling, and delivery costs of forwarding a new water heater or replacement part(s) to the owner.
2. All costs necessary or incidental in removing the defective water heater or component part(s) and installing a new water heater or replacement part(s).
3. All administrative fees incurred by the Owner, as well as material required to complete, and/or permits required for, installation of a new water heater or replacement part(s), and
4. All costs necessary or incidental in returning the defective water heater or component part(s) to a location designated by the manufacturer.

#### **LIMITATIONS OF YOUR HTP WARRANTY AND REMEDIES**

**THE FOREGOING WARRANTIES ARE EXCLUSIVE AND ARE GIVEN AND ACCEPTED TO THE FURTHEST EXTENT UNDER APPLICABLE LAW IN LIEU OF ANY AND ALL OTHER WARRANTIES, EXPRESS OR IMPLIED, INCLUDING WITHOUT LIMITATION THE IMPLIED WARRANTIES OF MERCHANTABILITY AND FITNESS FOR A PARTICULAR PURPOSE AND ANY OBLIGATION, LIABILITY, RIGHT, CLAIM OR REMEDY IN CONTRACT OR TORT, WHETHER OR NOT ARISING FROM HTP'S NEGLIGENCE, ACTUAL OR IMPUTED. THE REMEDIES OF THE OWNER SHALL BE LIMITED TO THOSE PROVIDED HEREIN TO THE EXCLUSION OF ANY OTHER REMEDIES INCLUDING WITHOUT LIMITATION, INCIDENTAL OR CONSEQUENTIAL DAMAGES, SAID INCIDENTAL AND CONSEQUENTIAL DAMAGES INCLUDING, BUT NOT LIMITED TO, PROPERTY DAMAGE, LOST PROFIT OR DAMAGES ALLEGED TO HAVE BEEN CAUSED BY ANY FAILURE OF HTP TO MEET ANY OBLIGATION UNDER THIS AGREEMENT INCLUDING THE OBLIGATION TO REPAIR AND REPLACE SET FORTH ABOVE. NO AGREEMENT VARYING OR EXTENDING THE FOREGOING WARRANTIES, REMEDIES OR THIS LIMITATION WILL BE BINDING UPON HTP. UNLESS IN WRITING AND SIGNED BY A DULY AUTHORIZED OFFICER OF HTP. THE WARRANTIES STATED HEREIN ARE NOT TRANSFERABLE AND SHALL BE FOR THE BENEFIT OF THE OWNER ONLY.**

#### **NO OTHER WARRANTIES**

This warranty gives the Owner specific legal rights. The Owner may also have other rights that vary from state to state. Some states do not allow the exclusion or limitation of incidental or consequential damages so this limitation or exclusion may not apply to the Owner.

These are the only written warranties applicable to the water heater manufactured and sold by HTP. HTP neither assumes nor authorizes anyone to assume for it any other obligation or liability in connection with said water heaters.

HTP reserves the right to change specifications or discontinue models without notice.





**Customer Installation Record Form**

The following form should be completed by the installer for you to keep as a record of the installation in case of a warranty claim. After reading the important notes at the bottom of the page, please also sign this document.

Customer's Name	
Date of Installation	
Installation Address	
Product Name / Serial Number(s)	
Comments	
Installer's Code / Name	
Installers Phone Number	
Signed by Installer	
Signed by Customer	

**IMPORTANT**

Customer: Please only sign after the installer has fully reviewed the installation, safety, proper operation, and maintenance of the system. If the system has any problems please call the installer. If you are unable to make contact, please call your sales representative.

Distributor / Dealer: Please insert contact details.