

CHECK VALVE WITH ORIFICE PRESSURE SENSING LINE

Figure 1110



NFP1110D

FEATURES & BENEFITS

- Size: 1/2" IPS with 3/32" orifice
- Designed for use in pressure sensing lines for fire pump systems
- Finish: Rough brass
- Material: Brass body and disc
- Designed for horizontal installation only

INSTALLATION

Install in the pressure sensing line according to the fire pump manufacturer's recommendations using appropriate tools and sealants. Make sure excess thread sealants are not introduced inside the check valve during assembly. Excess sealants will clog the 3/32" orifice preventing proper sensing line function.



CAUTION: DO NOT OVERTIGHTEN THREADS.
OVERTIGHTENING MAY CAUSE VALVE FAILURE.

Not approved for potable water applications

CHECK VALVE WITH ORIFICE PRESSURE SENSING LINE

Figure 1110

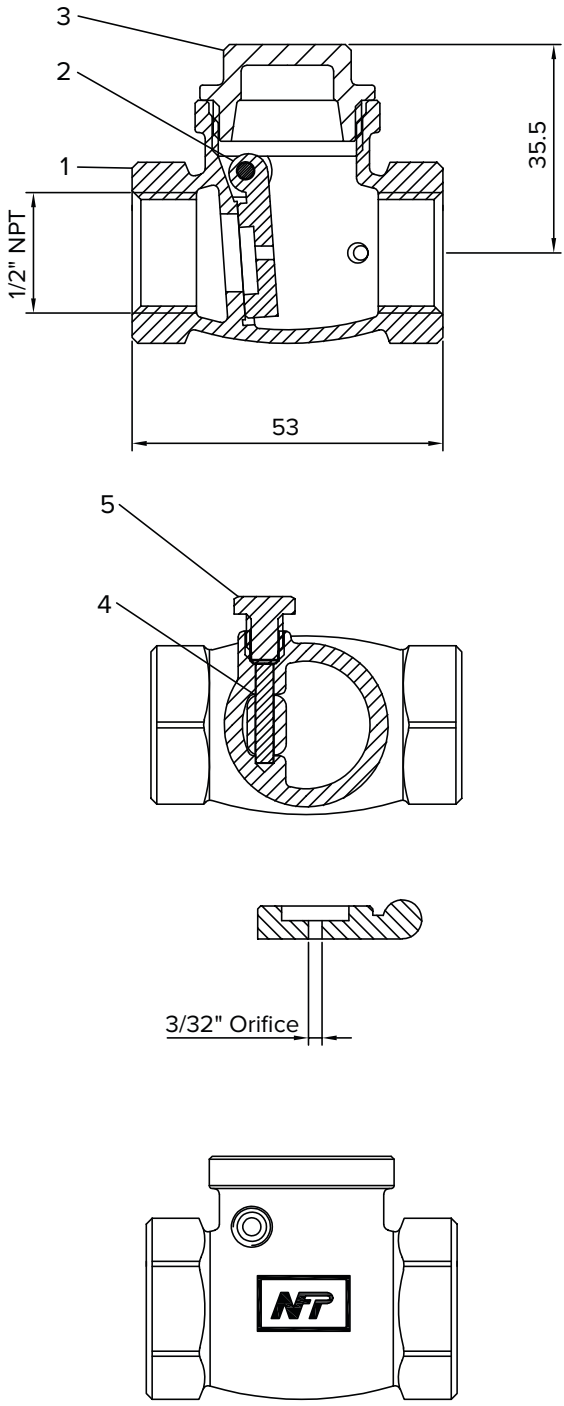

DIMENSION (INCHES)

PART #	SIZE	A	B
NFP1110D	1/2"	2.09	1.40

MATERIAL CHART

NO.	PART NAME	MATERIAL
1	Body	Cast brass B584 C857000
2	Disc	Forged brass B16 C36000
3	Cap cover	Cast brass B584 C857000
4	Pin	Brass B111 C28000
5	Plug	Brass B16 C36000