

Installation and Operation Instructions for

MINI-THERM[®] **JX**

Residential Gas-Fired Hydronic Boilers

Sizes 50-200 MBTU/h

FOR YOUR SAFETY: This product must be installed and serviced by a professional service technician, qualified in hot water boiler and heater installation and maintenance. Improper installation and/or operation could create carbon monoxide gas in flue gases which could cause serious injury, property damage, or death. Improper installation and/or operation will void the warranty.

⚠ WARNING

If the information in this manual is not followed exactly, a fire or explosion may result causing property damage, personal injury or loss of life.

Do not store or use gasoline or other flammable vapors and liquids in the vicinity of this or any other appliance.

WHAT TO DO IF YOU SMELL GAS

- Do not try to light any appliance.
- Do not touch any electrical switch; do not use any phone in your building.
- Immediately call your gas supplier from a nearby phone. Follow the gas supplier's instructions.
- If you cannot reach your gas supplier, call the fire department.

Installation and service must be performed by a qualified installer, service agency, or gas supplier.

⚠ AVERTISSEMENT

Assurez-vous de bien suivre les instructions données dans cette notice pour réduire au minimum le risque d'incendie ou d'explosion ou pour éviter tout dommage matériel, toute blessure ou la mort.

Ne pas entreposer ni utiliser d'essence ni d'autres vapeurs ou liquides inflammables dans le voisinage de cet appareil ou de tout autre appareil.

QUE FAIRE SI VOUS SENTEZ UNE ODEUR DE GAZ:

- Ne pas tenter d'allumer d'appareils.
- Ne touchez à aucun interrupteur. Ne pas vous servir des téléphones dans le bâtiment où vous êtes.
- Appelez immédiatement votre fournisseur de gaz depuis un voisin. Suivez les instructions du fournisseur.
- Si vous ne pouvez rejoindre le fournisseur de gaz, appelez le service des incendies.

L'installation et l'entretien doivent être assurés par un installateur ou un service d'entretien qualifié ou par le fournisseur de gaz.

TABLE OF CONTENTS

SECTION 1 GENERAL INFORMATION

1.A Introduction..... 4
 1.B Warranty 4
 1.C Model Number and Nomenclature 4
 1.D Safety Warnings 5
 1.E Model Overview..... 6
 1.F Pressure Gauge 8
 1.G Digital Dashboard..... 8
 1.H The Installation Kit..... 8
 1.I Accessory Kits Available..... 8
 1.J Dimensions..... 8

SECTION 2 LOCATING THE BOILER

2.A Field Assembly 10
 2.B Boiler Placement 10
 2.C Clearances 10

SECTION 3 AIR AND VENTING

3.A Safety Warnings 11
 3.B Combustion Air Supply 12
 3.C Venting 13
 3.D Vertical Venting - Category I 14
 3.E Locations for Vent Pipe Terminator..... 15
 3.F Venting with a Power Venter 16
 3.G Common Vent Test 16

SECTION 4 GAS CONNECTIONS

4.A Gas Supply and Piping..... 17
 4.B LP Gas Conversion Kit 18
 4.C Special Precautions for LP Gas..... 18

SECTION 5 PUMP REQUIREMENTS

5.A Pump Sizing WITH Low Loss Header and an Integral Pump 19
 5.B Pump Sizing WITHOUT Low Loss Header 19

SECTION 6 WATER CONNECTIONS

6.A Water Piping 20
 6.B Oxygen Permeable Systems 20
 6.C Anti-freeze 20
 6.D Typical Plumbing Diagrams..... 21

SECTION 7 ELECTRICAL AND WIRING DIAGRAMS

7.A Safety Warnings 23
 7.B Main Power, 120V / 15 Amp Circuit..... 23
 7.C Outdoor Sensor 23
7.D Field Connections 24
7.D.1 TB1 (Term Block 1 -TT, DHW, OAS) . 24
 7.D.1.a TT (Central Heat)..... 24
 7.D.1.b DHW. 24
 7.D.1.c Field Interlocks 24
 7.D.1.d PV Terminals 24
 7.D.1.e WWSD + COM 24
 7.D.1.f OAS + COM 24
7.D.2 TB2 (for pumps and aux power) 25
 7.D.2.a Boiler Pump..... 25
 7.D.2.b SYS Pump..... 25
 7.D.2.c Aux Power 25
7.D.3 TB3 (for optional equipment) 25
 7.D.3.a DHW Pump 25
 7.D.3.b DHW Aquastat..... 25
 7.E Wiring Connections, Power Vent and Air 26
 7.F Wiring Diagram..... 28
 7.G Logic Diagram 29

SECTION 8 THE DIGITAL DASHBOARD

8.A Getting to know the Digital Dashboard. 30
 8.A.1 The Lo Limit Dial (Advanced Programing) 30
 8.A.2 The Hi Limit Dial (Program Select) 30
 8.A.3 Economy Dial (no outdoor sensor needed)..... 31
 8.A.4 Mode 31
 8.A.5 Control LEDs 31
 8.A.5.a TS ACTIVE (TEMP) 31
 8.A.5.b HIGH TEMP 31
 8.A.5.c LWS ACTIVE (LWCO) 31
 8.A.5.d LOW WATER 31
 8.A.5.e TEMP ACTIVE (ECONOMY)..... 31
 8.A.5.f TEMP TARGET 31
 8.A.6 Digital LEDs 31
 8.A.7 Ignition LEDs 32
 8.A.7.a LIMITS 32
 8.A.7.b V-PWR..... 32
 8.A.7.c V-SW 32
 8.A.7.d FLAME 32

8.B	Advanced Programing	32
8.B.1	Fahrenheit or Celsius	32
8.B.2	Low Water Cut-Off	32
8.B.2.a	RESET, Manual or Automatic	32
8.B.2.b	Testing Low Water Cut OFF	33
8.B.3	High Limit Differential	33
8.C	Sensor Programming	33
8.C.1	Outdoor Sensors	33
8.C.2	Setting Warm Weather Shutdown	33
8.C.3	Adjusting Outdoor Reset Ratio	34
8.C.4	Thermal Boost Function	34
8.C.4.a	Outdoor Reset	34
8.C.4.b	Thermal Targeting.....	35
8.D	Restore Factory Default Settings.....	35
8.E	View Current Settings	35
8.F	DHW Functionality.....	35

SECTION 9 INITIAL STARTUP

9.A	Filling the System	36
9.B	System Start Up (Seq of Operation).....	36
9.C	Proper Pilot Flame.....	38
9.D	Lighting Instructions Decal	39
9.E	System Shutdown	40

SECTION 10 MAINTENANCE

10.A	Removing the Covers and Panels.....	40
10.A.1	Access Cover Removal	40
10.A.2	Flue Collector Access	40
10.A.3	Side Panel Removal	41
10.A.4	Draft Hood Removal	41
10.B	Maintenance	42

SECTION 11 OPERATING DETAILS AND TROUBLESHOOTING

11.A	Operating Details.....	43
11.B	Electrical Troubleshooting	43
11.C	Troubleshooting Table	44
11.D	Troubleshooting Flow Charts.....	45
11.D.1	Troubleshtng Flow Chart 1 (burners off)..	45
11.D.2	Troubleshtng Flow Chart 2 (burners on) .	46
11.E	Glossary of Terms.....	47

SECTION 12 REPLACEMENT PARTS

12.A	Parts List	48
12.B	Accessories List	49



SECTION 1 GENERAL INFORMATION

1.A Introduction

NOTE: The Mini-Therm JX is designed for a variety of installation scenarios, but is factory set to a 'Default' setting in the controller and will not need to be programmed for most installations.

If your installation requires any of these advanced options:

- Setting the low water cut-off to manual reset.
- Adjusting high limit to anything other than 190°F/88°C.
- Installing an outdoor sensor for the purpose of setting the Reset Curve.
- Changing the temp readout from Fahrenheit to Celsius (or back to Fahrenheit).
- To change the economy settings.

THEN you will need to read "SECTION 8, THE DIGITAL DASHBOARD" on page 30 of this installation manual.

All application and installation procedures should be reviewed completely before proceeding with the installation. Consult the LAARS Heating Systems factory, or local factory representative, with any problems or questions regarding this equipment. Experience has shown that most operating problems are caused by improper installation.

1.B Warranty

The Laars Mini-Therm JX boilers are covered by a limited warranty. The owner should complete the warranty registration online by going to www.Laars.com and selecting the 'Support' pull-down to find the new product warranty registration form.

All warranty claims must be made to an authorized Laars representative or directly to the factory. Claims must include the boiler serial number and model (this information can be found on the rating plate), installation date, and name of the installer. Shipping costs are not

included in the warranty coverage.

Some accessory items are shipped in separate packages. Verify receipt of all packages listed on the packing slip. Inspect everything for damage immediately upon delivery, and advise the carrier of any shortages or damage. Any such claims should be filed with the carrier. The carrier, not the shipper, is responsible for shortages and damage to the shipment whether visible or concealed.

The warranty does not cover damage caused by improper assembly installation, operation or field modification.

1.C Model Number and Nomenclature

Consult the rating plate on the side of the unit. The following information describes the model number structure.

1st, 2nd Characters (Series Name)

JX = Mini-Therm JX

3rd thru 5th Characters (Size)

Input MBTU / H

6th Character (fuel)

N = Natural Gas

7th Character (Config)

X = Standard 50-100

L = Standard 125-200

(Low Loss Header & Pump Installed)

P = 50-100 with Pump Kit

8th Character (Altitude in Feet)

X = (0 - 2,000)

H = (2,001 - 5,000)

I = (5,001 - 8,000)

9th Character (Country)

U = USA & Canada

10th Character (Revision)

1 = 1st Revision

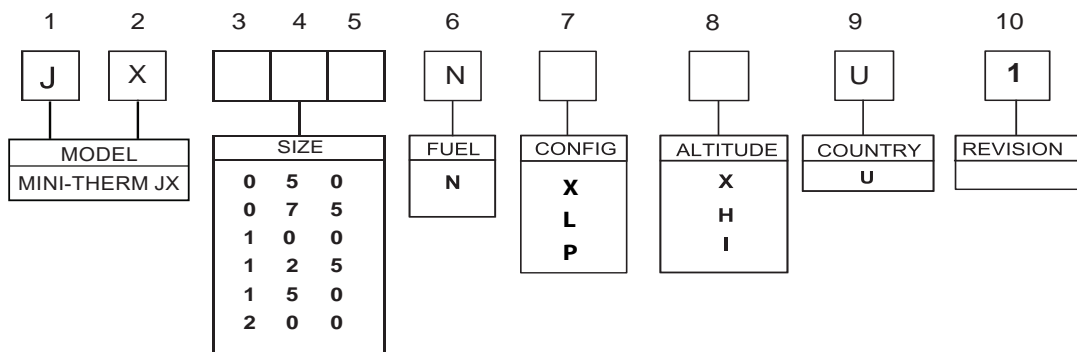

Figure 1. Model Nomenclature

1.D Safety Warnings

Safety Warnings are used throughout this manual to bring attention to the presence of hazards with various risk levels and to offer important information concerning the life of this product. There are 3 basic types.

1	⚠ WARNING	Indicates an imminently hazardous situation which, if not avoided, can or will result in death or serious injury and can or will result in catastrophic property damage.
2	⚠ CAUTION	Indicates a potentially hazardous situation which, if not avoided, may result in moderate injury and/or property damage.
3	NOTE:	Indicates instructions that are important to that topic but not related to personal injury or property damage.

⚠ WARNING

- Water temperature over 125°F (52°C) can cause severe burns instantly or death from scalds.
- Children, disabled and elderly are at highest risk of being scalded.
- See instruction manual before setting temperature at the unit.
- Feel water before bathing or showering.
- If this unit is used to produce water that could scald if too hot, such as domestic hot water use, adjust the outlet control (limit) or use temperature limiting valves to obtain a maximum water temperature of 125°F (52°C).



⚠ WARNING

The inlet gas pressure to the unit must not exceed 13" W.C. (3.2kPa).

⚠ WARNING

This unit must be installed in accordance with the procedures detailed in this manual, or the manufacturers warranty will be voided. The installation must conform to the requirements of the local jurisdiction having authority, and, in the United States, to the latest edition of the National Fuel Gas Code, ANSI Z223.1/NFPA54. In Canada, the installation must conform to the latest edition of CSA B149.1 Natural Gas and Propane Gas Installation Code, and/or local codes. Where required by the authority having jurisdiction, the installation of these units must conform to the Standard for Controls and Safety Devices for Automatically Fired Boilers, ANSI/ASME CSD-1. Any modifications to the boiler, its gas controls, or wiring may void the warranty. If field conditions require modifications, consult the factory representative before initiating such modifications.

⚠ WARNING

Fire or Explosion Hazard

Improper configuration can cause fuel buildup and explosion. Improper user operation may result in property loss, severe physical injury, or death.

Any changes to safety-related configuration parameters must only be done by experienced and/or licensed burner/boiler operators and mechanics.

If any odor of gas is detected, or if the gas burner does not appear to be functioning in a normal manner, close the main gas shutoff valve. Do not shut off the power switch. Contact your heating contractor, gas company, or factory representative.

⚠ WARNING

Carbon Monoxide Hazard

Improper adjustment of the burners may lead to poor combustion quality, increasing the amount of carbon monoxide produced. Excessive carbon monoxide levels may lead to personal injury or death.

NOTE: This unit is protected against hydronic over-pressurization. A pressure relief valve is included with each unit.

⚠ WARNING

CANCER AND REPRODUCTIVE HARM.
WWW.P65WARNINGS.CA.GOV.

AS REQUIRED BY THE STATE OF CALIFORNIA PROPOSITION 65.

1.D Safety Warnings (continued)

⚠ WARNING

The Repair Parts list designates parts that contain refractory ceramic fibers (RCF). RCF has been classified as a possible human carcinogen. When exposed to temperatures above 180°F, such as during direct flame contact, RCF changes into crystalline silica, a known carcinogen. When disturbed as a result of servicing or repair, these substances become airborne and, if inhaled, may be hazardous to your health.

Do not remove or replace RCF parts or attempt any service or repair work involving RCF without wearing the following protective gear:

1. A National Institute for Occupational Safety and Health (NIOSH) approved respirator.
2. Long sleeved, loose fitting clothing.
3. Gloves.
4. Eye Protection.

⚠ WARNING

Electrical Shock Hazard

Electrical shock can cause severe injury, death or property damage. Disconnect the power supply before beginning installation or changing the wiring to prevent electrical shock or damage to the equipment. It may be necessary to turn off more than one power supply to disconnect.

All electrical wiring is to be done in accordance with local codes, or in the absence of local codes, with: 1) The National Electrical Code ANSI/NFPA No. 70 - latest Edition, or 2) CSA STD. C22.1 "Canadian Electrical Code - Part 1." This appliance must be electrically grounded in accordance with these codes.

⚠ WARNING

Should overheating occur or the gas supply fail to shut off, do not turn off or disconnect the electrical supply to the pump. Instead, shut off the gas supply at a location external to the appliance.

⚠ AVERTISSEMENT

En cas de surchauffe au si l'admission de gaz ne peut etre coupee, ne pas couper ni debrancher l'alimentatio electrique de la pompe. Fermer plutot le robinet d'admission de gaz a l'exterieur de l'appareil.

1.E Model Overview

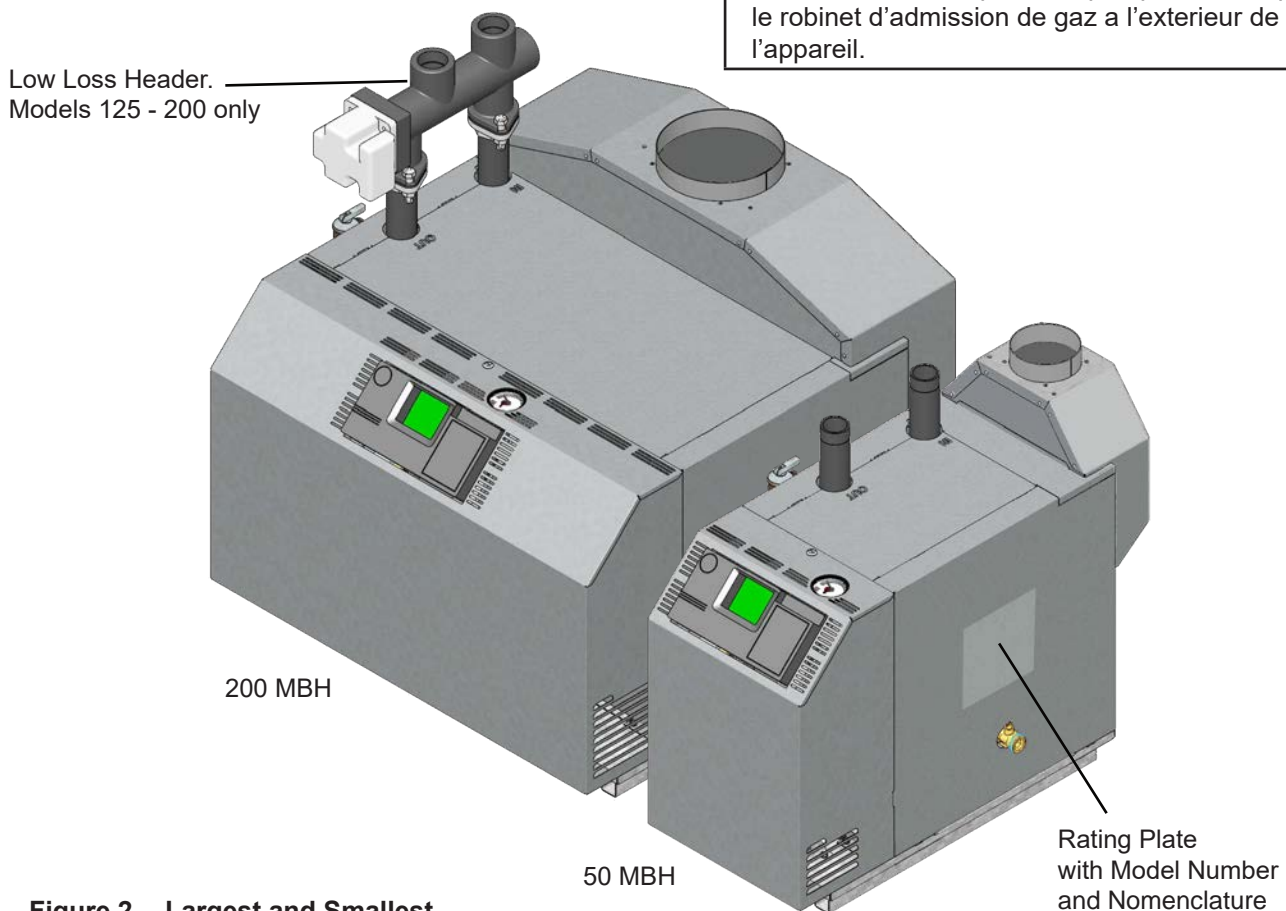

Figure 2. Largest and Smallest

1.E Model Overview (continued)

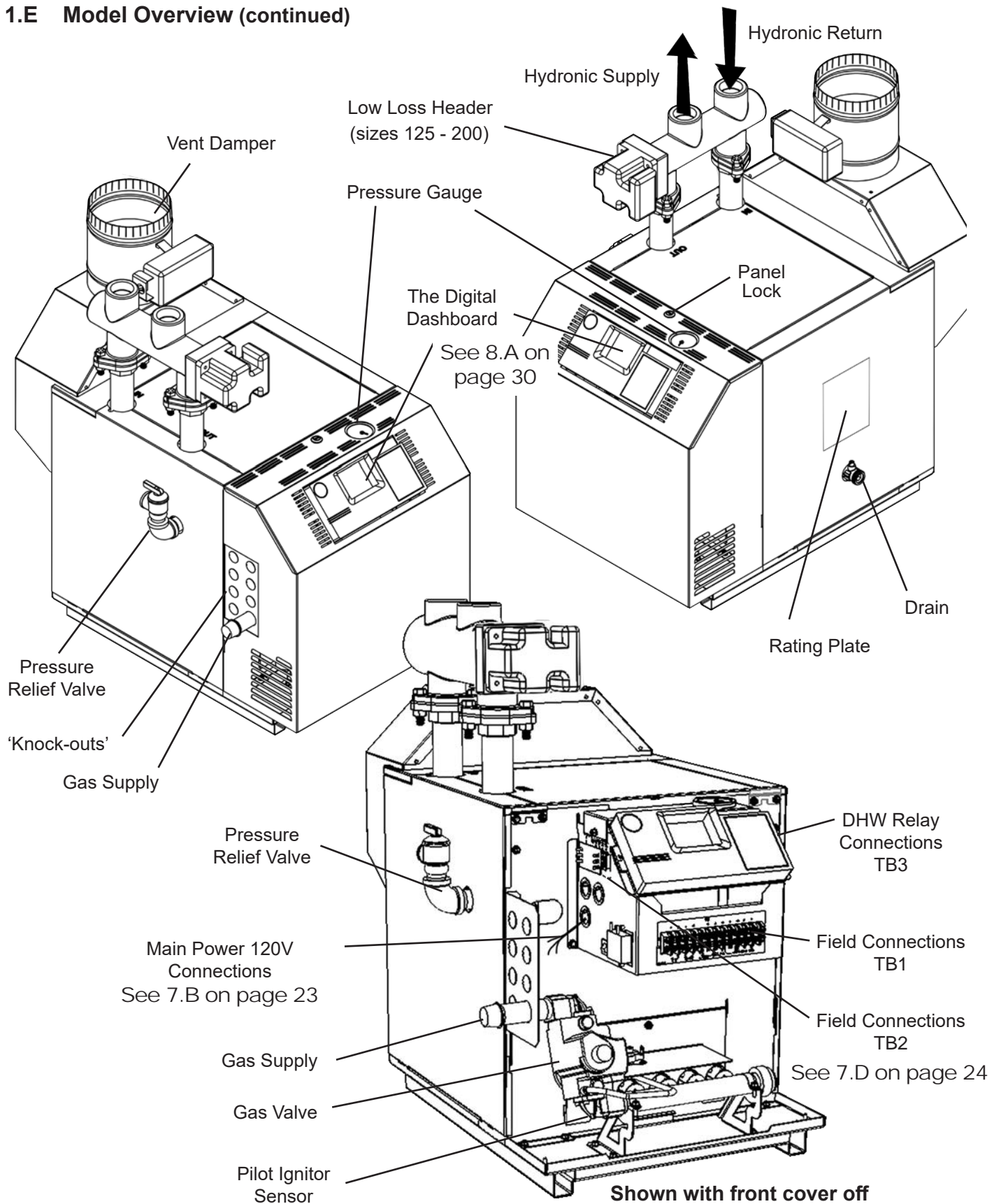

Figure 3. Location of Components

1.F Pressure Gauge



Figure 4. System Pressure

The Pressure gauge is installed just above the Digital Dashboard. The pressure is sensed at the top front section of the inlet/outlet header.

1.G Digital Dashboard

The Digital Dashboard displays the boiler's status while it is running. The dials and the mode button are underneath the removable transparent cover and allow for advanced settings and installations that have outdoor reset and Low Water Cut Off (LWCO) with manual reset and several other advanced settings. See SECTION 8 on page 30.



Figure 5. Boiler Status

1.H The Installation Kit

This residential unit is shipped in a single crate with a boxed installation kit that contains these components.

1. I/O Manual
2. Vent Damper
3. Burner Air Shutter Gauge (Mini Gauge)

1.I Accessory Kits Available

See Section 12.B on page 50 for part numbers.

- Low Loss Header with Integral Pump for 50 - 100 (Standard on larger models)
- Conversion kits for LP and altitude are available from 0 to 10,000' both fuels.
- Domestic Hot Water Pump Relay Kit
- Power Vent Kits
- Outdoor Air Sensor

1.J Dimensions

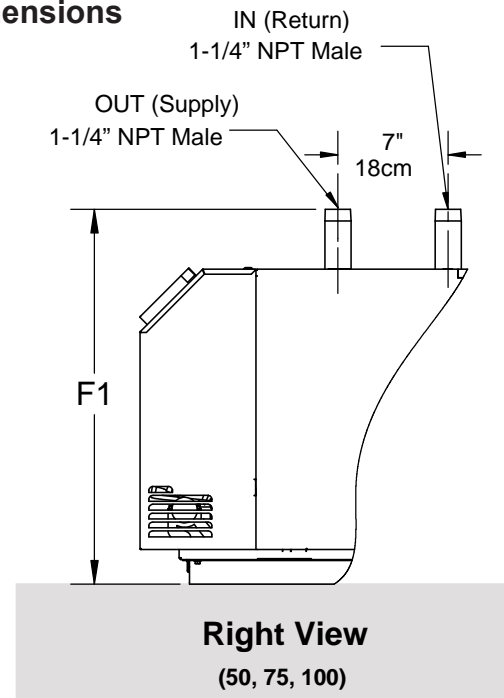

1.J Dimensions (continued)

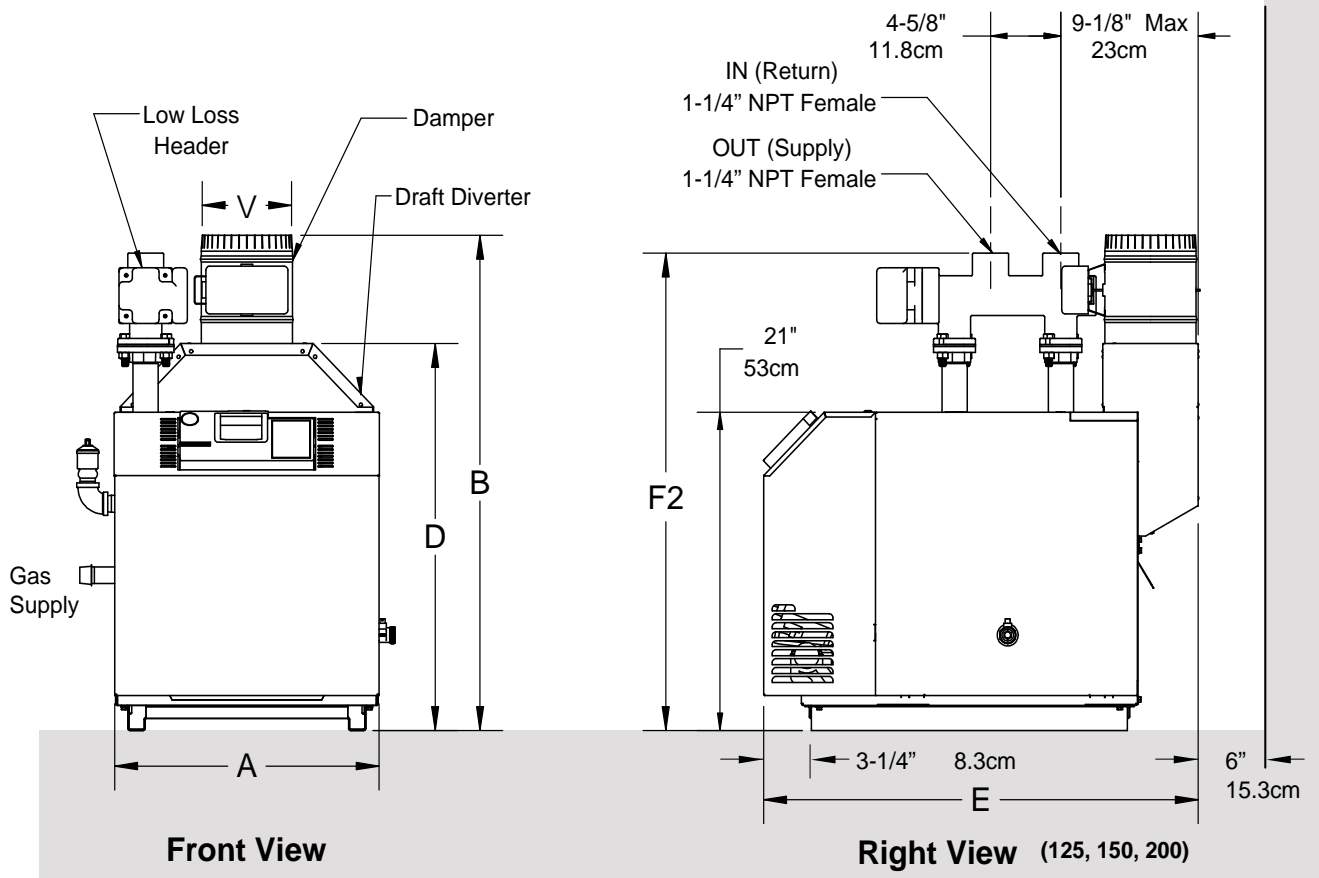
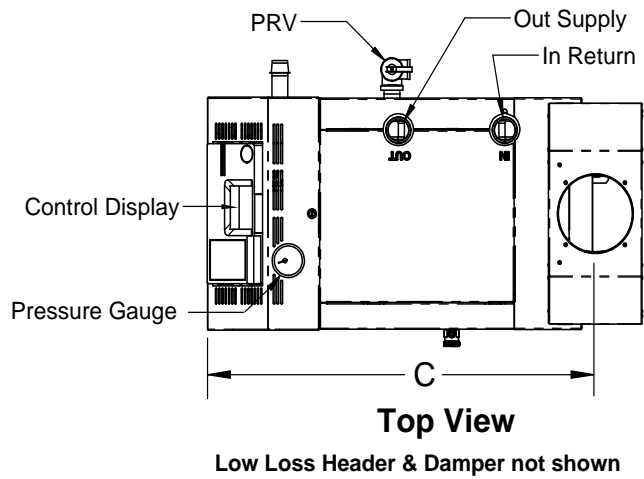

SIZE	A		B		C		D		E		F1		F2		V		WATER CONN (inches)	GAS CONN (inches)
	in.	cm	in.	cm	in.	cm	in.	cm	in.	cm	in.	cm	in.	cm	in.	cm		
50	11-3/4	30	31-5/8	80	25-1/8	64	24-3/4	63	27-5/8	70	24-7/8	63	-	-	4	10	1-1/4	3/4
75	14-1/2	37	31-5/8	80	25-5/8	65	24-3/4	63	28-5/8	73	24-7/8	63	-	-	5	13	1-1/4	3/4
100	17-3/8	45	32-1/8	82	25-1/2	65	25-3/8	65	28-5/8	73	24-7/8	63	-	-	5	13	1-1/4	3/4
125	20-1/8	52	32-1/8	82	25	64	25-3/8	65	28-5/8	73	-	-	31	79	6	15	1-1/4	3/4
150	23	59	32-1/8	82	25	64	25-3/8	65	28-5/8	73	-	-	31	79	6	15	1-1/4	3/4
200	28-3/8	73	32-1/4	82	24-5/8	63	26-1/4	67	28-5/8	73	-	-	31	79	7	18	1-1/4	3/4

Table 1. Dimensions

SECTION 2 LOCATING THE BOILER

2.A Field Assembly

This boiler is shipped with an automatic vent damper that must be assembled onto the vent collar on the top of the boiler, and then plugged into the unit using the dedicated harness.

2.B Boiler Placement

This boiler is design certified by CSA-International for indoor installation on combustible flooring, in basements, in closets, utility rooms or alcoves. **These units must never be installed on carpeting.**

1. This boiler is designed for indoor installations only and should be located to provide clearances on all sides for maintenance and inspection. See Figure 6. It should not be located in an area where leakage of any connections will result in damage to the area adjacent to the unit or to lower floors of the structure. When such a location is not available, it is recommended that a suitable drain pan, adequately drained, be installed under the unit.

2. A minimum of 15" (381mm) access must be available in front of the boiler for burner removal. Consult local codes for clearances to hot water pipes and accessories.
3. If the boiler is to be installed in a garage, all burners and burner ignition devices must have a minimum 18" (457mm) clearance above the floor.
4. Boilers may be installed in a closet as long as all minimum clearances are followed, including between the front of the boiler and the closet door when it is closed. See Figure 6. Consult the American National Standard Z21.13 for more information concerning closet installations. In Canada, refer to the latest edition of CSA-B149.1.
5. When vented vertically, the unit must be located as close as practical to the vertical section of the vent. When a power venter is used with a terminal through a wall, and there is a potential for snow accumulation, the terminal must be installed at an appropriate level above grade or the maximum expected snow line.

NOTE: For installation on combustible flooring.

2.C Clearances

NOTE: For Closet Installation Clearances, the minimum clearance between hot water pipes and combustible construction is 1" (2.5 cm.)

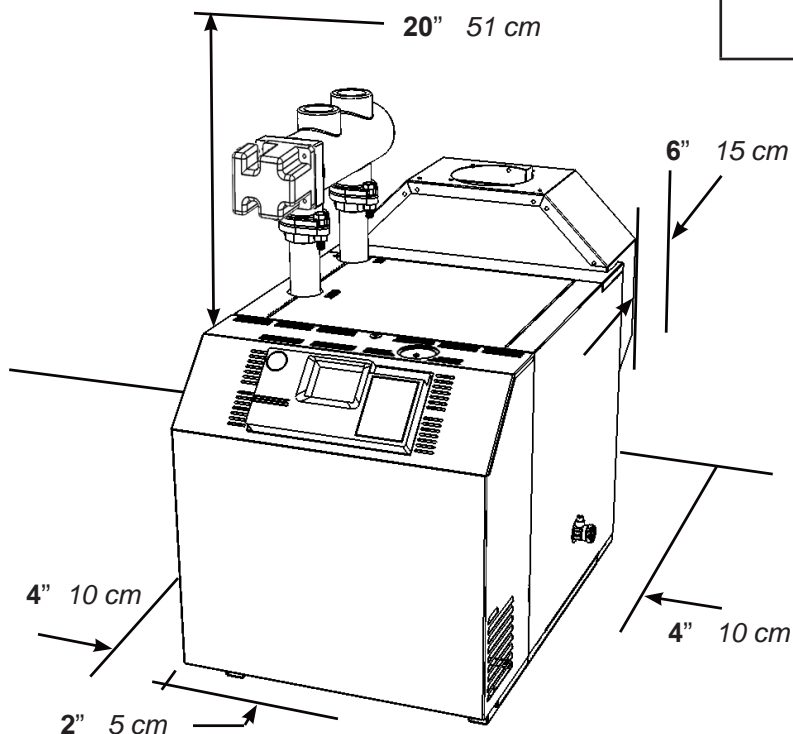

Figure 6. Minimum Clearances

SECTION 3 Air and Venting

3.A Safety Warnings

WARNING

This boiler must be vented in accordance with Part 7, Venting of Equipment, of the latest edition of the National Fuel Gas code, NFPA 54/ANSI Z223.1 and all applicable local building codes. In Canada, follow CAN/CSA B149.1 Installation codes. Improper venting of this appliance can result in excessive levels of carbon monoxide which can result in severe personal injury or death!

AVERTISSEMENT

Cette chaudière doit être ventilé, conformément aux dispositions de la partie 7, de la ventilation de l'équipement, de la dernière édition du National gaz carburant code, NFPA 54/ANSI Z223.1 et tous les codes du bâtiment locaux. Au Canada, CAN/CSA B149.1 codes d'installation. Une mauvaise ventilation de cet appareil peut entraîner des niveaux excessifs de monoxyde de carbone qui peut entraîner de graves blessures ou la mort!

WARNING

Operation of appliances with a blocked common vent may lead to serious injury or death. Safety devices must be implemented to prevent blocked common vent operation. If safe operation of all appliances connected to a common vent cannot be assured, including prevention of spillage of flue gasses into living spaces, common venting should not be applied, and appliances should each be vented separately.

AVERTISSEMENT

Le fonctionnement des appareils avec un système d'évacuation bloqué peut provoquer des blessures graves, voire la mort. Des dispositifs de sécurité doivent être installés pour éviter le blocage des systèmes d'évacuation. Si le fonctionnement de tous les appareils connectés à un système d'évacuation commun ne peut pas être assuré, y compris la prévention de la dispersion des gaz toxiques dans les espaces habités, on ne devrait pas installer un système d'évacuation commun et chaque appareil devrait être ventilé séparément.

WARNING

For Category I, II and IV boilers, have horizontal runs sloping upwards not less than ¼ inch per foot (21 mm/m) from the boiler to the vent terminal.

AVERTISSEMENT

les chaudières de catégories I, II et IV doivent présenter des tronçons horizontaux dont la pente montante est d'au moins ¼ po par pied (21 mm/m) entre la chaudière et l'évent.

WARNING

Damper must be in open position when appliance main burner(s) is operating.

For use only with automatic vent damper device. Follow installation instructions.

This boiler needs fresh air for safe operation and must be installed so there are provisions for adequate combustion and ventilation air.

AVERTISSEMENT

Le registre doit être ouvert lorsque le brûleur principal de l'appareil fonctionne.

Pour utilisation avec un registre de conduit d'évacuation automatique, Suivre les instructions d'installation.

Cette chaudière doit être alimentée en air frais pour fonctionner en toute sécurité et doit être installée de façon que la combustion et l'alimentation en air de ventilation soient adéquates.

3.B Combustion Air Supply

The boiler location must provide sufficient air supply for proper combustion, and ventilation of the surrounding area as outlined in the latest edition of U.S. ANSI standard Z223.1 or in Canada, CAN/CSA-B149.1 and any local codes that may be applicable.

In general, these requirements specify that the boiler rooms which represent confined spaces should be provided with two permanent air supply openings; one within 12 inches (305mm) of the ceiling, the other within 12 inches (305mm) of the floor.

NOTE: In Canada, follow Canadian Standard, CAN/CSA-B149.1 or local codes.

Outside Air Supply: When combustion air is supplied directly through an outside wall, each opening should have a minimum free area of one square inch per 4,000 BTU/h (6 sq. cm per 1.2 kW) input of the total input rating of all appliances in the enclosed area.

Inside Air Supply: When combustion is supplied from inside the building, each opening should have a minimum free area of one square inch per 1,000 BTU/h (6 sq. cm per 0.3 kW) input of the total input rating of all appliances in the enclosed area. These openings should never be less than 100 square inches (645 sq. cm).

Exhaust Fans or Vents: Any equipment which exhausts air from the boiler room can deplete the combustion air supply or reverse the natural draft action of venting system. This could cause flue products to accumulate in the boiler room. Additional air must be supplied to compensate for such exhaust.

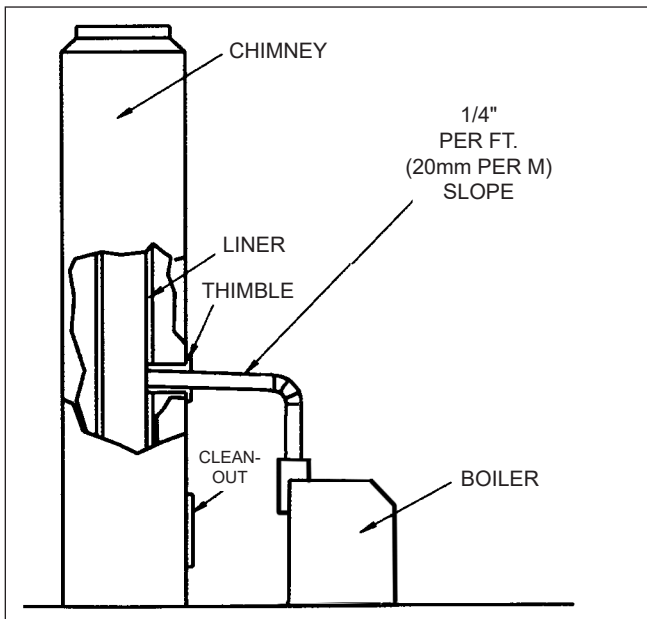

Figure 7. Chimney Venting (clay lined).

Boiler Size	Outside Air Area		Inside Air Area	
	sq. in	sq. cm	sq. in.	sq. cm
50	13	84	100	645
75	19	123	100	645
100	25	161	100	645
125	31	200	125	807
150	38	245	150	968
200	50	323	200	1290

*Area indicated is for one of two openings: one at floor level and one at the ceiling, so the total net free area would be double the figures shown. For special conditions, refer to NFPA54 ANSI Z223.1. In Canada, refer to the National Standard CSA-B149.1 which differs from this table.

NOTE: Check with louver manufacturers for Net Free Area of Louvers. Correct for screen resistance to the Net Free Area if a screen is used.

Table 2. Minimum Recommended Air Supply to Boiler Room

The information in **Table 2** is not applicable in installations where exhaust fans or blowers of any type are used. Such installations must be designed by qualified engineers.

Mechanical Combustion Air Systems: If a blower or fan or automatic louvers are used to supply air to the boiler room, the installer should make sure it does not create drafts which could cause nuisance shutdowns. If a blower is necessary to provide adequate combustion air to the boiler, a suitable switch or equivalent must be wired into the boiler control circuit to prevent the boiler from firing unless the blower is operating. See "7.E Wiring Connections, Power Vent and Air" on page 26 for wiring diagram.

The boiler must be completely isolated and protected from any source of corrosive chemical fumes such as those emitted by trichloroethylene, perchloroethylene, chlorine, etc.

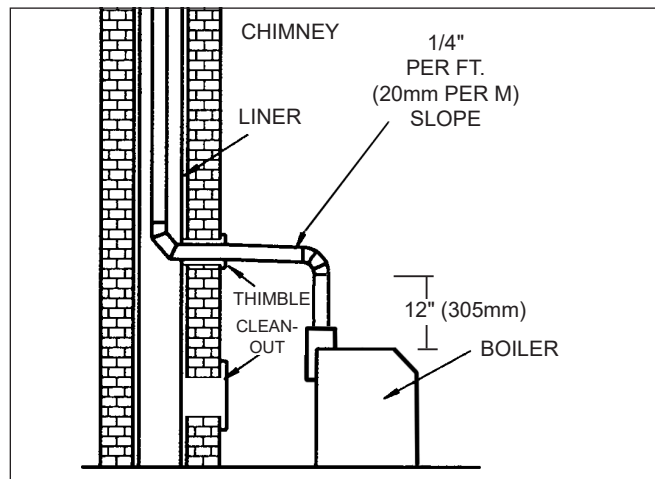

Figure 8. Vertical Venting (vent or manufactured chimney lining system).

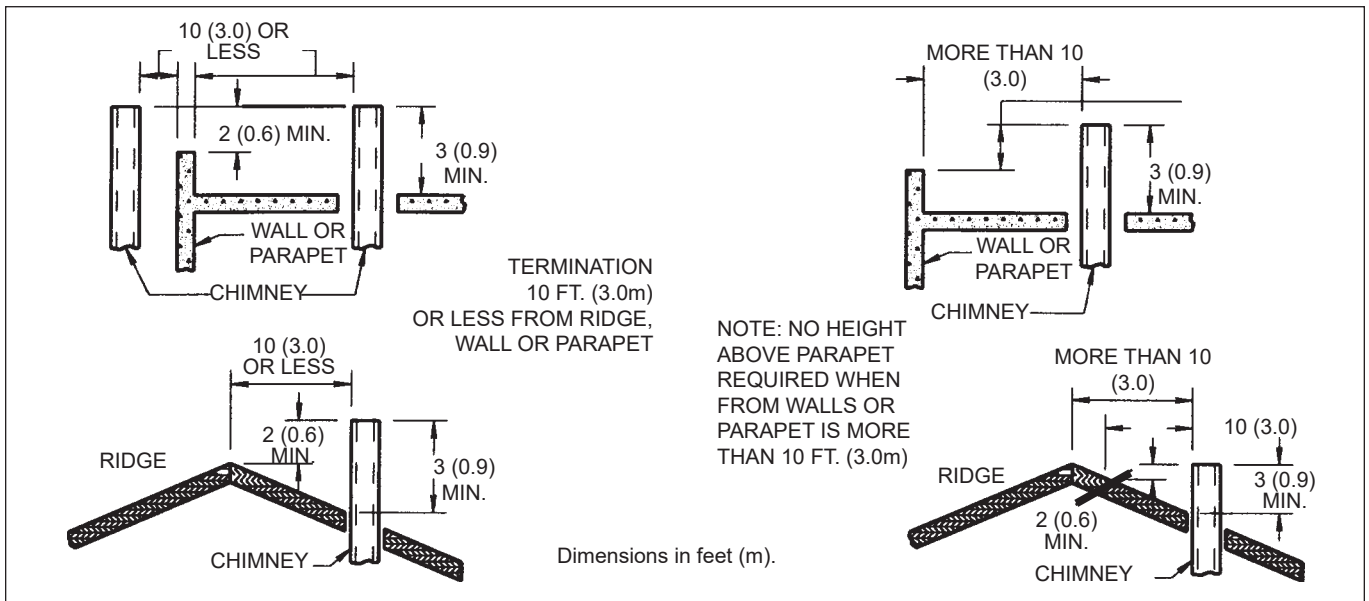

Figure 9. Vertical Vent Termination.

3.C Venting

Vent Category: This boiler is a natural draft appliance for Category I venting. It may also be vented using an optional power vent. Follow the instructions provided with the power venter. See 3.F for more information.

NOTE: When venting a Category I boiler, the vent damper must be fastened directly to the vent collar, and vent pipe must be fastened directly to the vent damper.

The installation must also conform to the requirements of applicable local codes, or in the absence of such codes, to the National Fuel Gas Code, ANSI Z223.1 and the National Electric Code, ANSI NFPA 70, or in Canada, CAN/CSA B149.1 (a vent damper may not be required in all Canadian jurisdictions) and B149.2 Installation Codes and the requirement of CSA C22.1, Part 1.

- Do not weld the vent pipe to the boiler collar.
- The weight of the stack must not rest on the boiler.
- The boiler top is designed so that it can be easily removed for normal boiler service and inspection without removal of the venting.
- Avoid terminating boiler vents near air conditioning or air supply fans. The fans can pick up exhaust flue products from the boiler and return them to the building, creating a possible health hazard.
- Avoid oversized vent pipe or extremely long runs of vent pipe, which may cause excessive cooling and condensation.
- When installing the vent system, all applicable national and local codes must be followed. The use of thimbles, firestops and other protective devices, when penetrating combustible or noncombustible

construction, must be in accordance with all applicable national and local codes.

- An unused lined chimney can be used as a raceway for single wall vent pipe. Never run vent pipe through a flue that has another appliance attached to it.

NOTE: The minimum return water temperature of the unit, in order to avoid condensation in the vent, is 130°F. The unit's control is equipped to protect against low temperatures, however the pumps must be installed and wired properly for this feature to function. The system pumps must be wired to the system pump terminals, and a boiler pump must be installed and wired to the boiler pump terminal (models 125 - 200 are built with LLH / boiler pump systems that are wired at the factory). See Figure 28 on page 27. If the system is not setup this way, condensation may occur which could damage venting systems.

3.D Vertical Venting - Category I

All venting must comply with fuel gas code and be installed by a licensed installer.

This boiler can be vented into a masonry chimney, (see Figure 7 and Figure 8 on page 12) provided several conditions are met:

1. The chimney must have an appropriate lining that is clean, properly constructed and properly sized.
2. The chimney passage way shall be examined to ascertain that it is clear and free of obstructions.
3. If a chimney rebuild is required, it shall conform to nationally recognized standards (see National Building Code or ANSI/NFPA 211).
4. The boiler must not be connected to a fireplace, wood stove or other solid fuel burning equipment.
5. When the boiler and a hot water heater are to be connected to the same chimney, they must have their own vent connector and enter the chimney at least 6" (152mm) apart.

IMPORTANT NOTE: Always provide a minimum clearance of 6" (152mm) between Type C (single wall) vent pipe and any combustible materials.

NOTE: Exterior masonry chimneys in very cold environments are at risk of condensing due to the high efficiency of this equipment. Insulated liners are recommended based on local conditions and expected system water temperatures. Also ensure the boiler's anti-condensing features are utilized by properly wiring the system pumps. See Figure 28 on page 27

WARNING

Do not store any chemical, cleaners, or other corrosive material near combustion air openings or in the room. Avoid locating dryer vents in the vicinity of combustion air openings. Failure to prevent corrosive materials from mixing with combustion air can result in reduced boiler life and unsafe boiler operation.

AVERTISSEMENT

N'entreposer aucun produit chimique, produit nettoyant ou produit corrosif à proximité des bouches d'air de combustion ou dans la pièce. Éviter de placer des tuyaux de ventilation pour sècheuse à proximité des bouches d'air de combustion. Le fait de laisser des matières corrosives se mélanger à l'air de combustion risque de réduire le cycle de vie de l'appareil de chauffage et de compromettre son fonctionnement.

WARNING

Single wall vent pipe must NEVER pass through interior walls or through floors or ceilings! Failure to comply with this warning could result in a fire causing property damage, personal injury, or death!

AVERTISSEMENT

Paroi simple tuyau d'évent doit jamais passer par l'intérieur les murs ou par planchers ou plafonds ! Le non-respect de cet avertissement peut provoquer un incendie causant des dommages matériels ou corporels, ou de mort!

3.E Locations for Vent Pipe Terminator

		Canadian Installations ¹	U.S. Installations ²
A =	Clearance above grade, veranda, porch, deck, or balcony	12 in (30 cm)	12 in (30 cm)
B =	Clearance to window or door that may be opened	<ul style="list-style-type: none"> 6 in (15 cm) for appliances ≤ 10,000 Btuh (3 kW) 12 in (30 cm) for appliances > 10,000 Btuh (3 kW) and ≤ 100,000 Btuh (30 kW) 36 in (91 cm) for appliances >100,000 Btuh (30 kW) 	<ul style="list-style-type: none"> 6 in (15 cm) for appliances ≤ 10,000 Btuh (3 kW) 9 in (23 cm) for appliances > 10,000 Btuh (3 kW) and ≤ 50,000 Btuh (15 kW) 12 in (30 cm) for appliances >50,000 Btuh (15 kW)
C =	Clearance to permanently closed window	See Note 4	See Note 5
D =	Vertical clearance to ventilated soffit located above the terminal within a horizontal distance of 2 ft (61 cm) from the center line of the terminal	See Note 4	See Note 5
E =	Clearance to unventilated soffit	See Note 4	See Note 5
F =	Clearance to outside corner	See Note 4	See Note 5
G =	Clearance to inside corner	See Note 4	See Note 5
H =	Clearance to each side of centerline extended above meter / regulator assy	3 ft (91 cm) within a height of 15 ft (4.6 m)	See Note 5
I =	Clearance to service regulator vent outlet	3 ft (91 cm)	See Note 5
J =	Clearance to nonmechanical air supply inlet to building or the combustion air inlet to any other appliance	<ul style="list-style-type: none"> 6 in (15 cm) for appliances ≤ 10,000 Btuh (3 kW) 12 in (30cm) for appliances > 10,000 Btuh (3 kW) and ≤ 100,000 Btuh (30 kW) 36 in (91 cm) for appliances > 100,000 Btuh (30 kW) 	<ul style="list-style-type: none"> 6 in (15 cm) for appliances ≤ 10,000 Btuh (3 kW) 9 in (23cm) for appliances > 10,000 Btuh (3 kW) and ≤ 50,000 Btuh (15 kW) 12 in (30 cm) for appliances > 50,000 Btuh (15 kW)
K =	Clearance to a mechanical air supply inlet	6 ft (1.83 m)	3 ft (91 cm) above if within 10 ft (3 m) horizontally
L =	Clearance above paved sidewalk or paved driveway located on public property	7 ft (2.13 m)†	7 ft (2.13 m) for mechanical draft systems (Category I appliances). Vents for Category II and IV appliances cannot be located above public walkways or other areas where condensate or vapor can cause a nuisance or hazard*
M =	Clearance under veranda, porch, deck, or balcony	12 in (30 cm)‡	See Note 5

† A vent shall not terminate directly above a sidewalk or paved driveway that is located between two single family dwellings and serves both dwellings.
 ‡ Permitted only if veranda, porch, deck, or balcony is fully open on a minimum of two sides beneath the floor.

Notes:

- 1) In accordance with the current CSA B149.1, Natural Gas and Propane Installation Code.
- 2) In accordance with the current ANSI Z223.1/NFPA 54, Natural Fuel Gas Code.
- 3) If locally adopted installation codes specify clearances different than those illustrated, then the most stringent clearance shall prevail.
- 4) For clearances not specified in CAN/CSA-B149, clearance is in accordance with local installation codes and the requirements of the gas supplier.
- 5) For clearances not specified in ANSI Z223.1/ NFPA 54, clearance is in accordance with local installation codes and the requirements of the gas supplier.
- 6) **IMPORTANT:** Terminal must be placed such that it remains a minimum of 12" above maximum expected snow line. Local codes may have more specific requirements, and must be consulted.

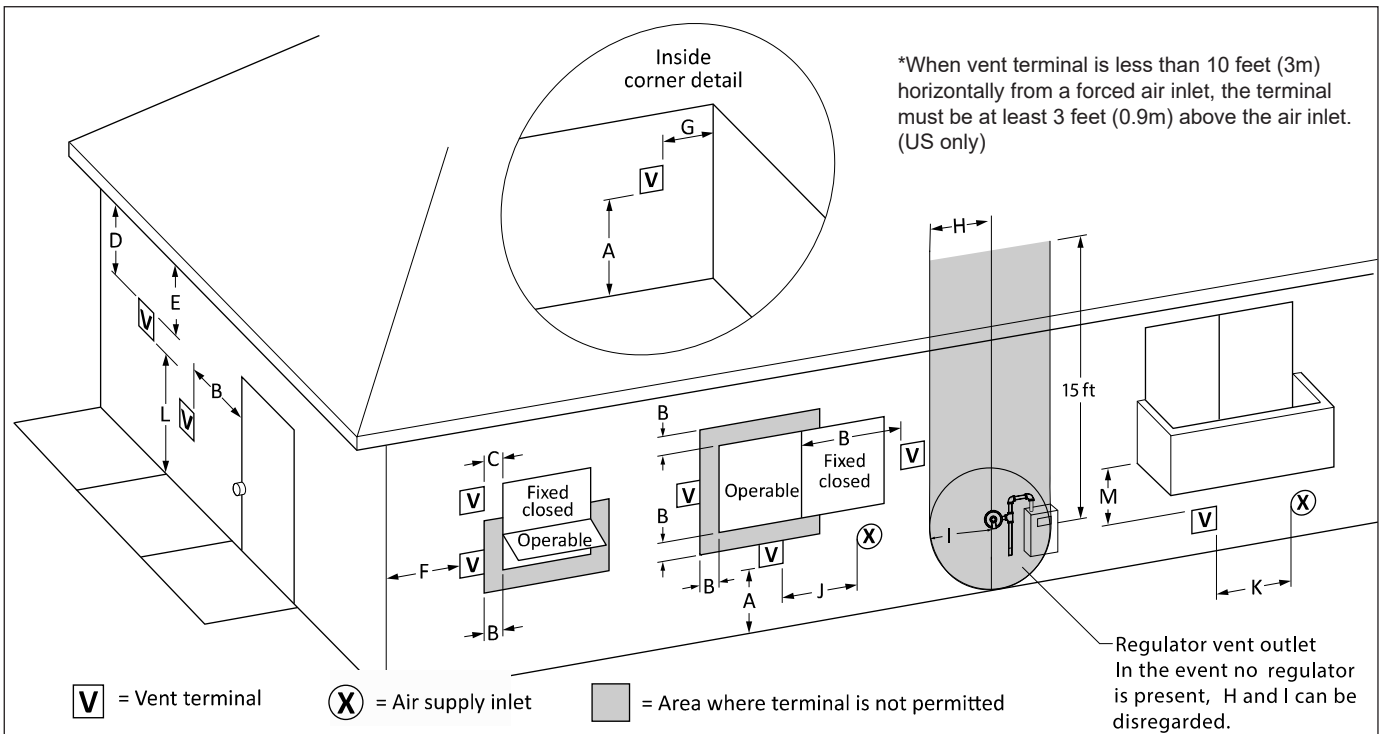

Figure 10. Combustion Air and Vent Through Side Wall

3.F Venting with a Power Venter

This boiler is certified for use with the manufacturer's suggested Power Venter, which is supplied in a kit that includes Installation Instructions. See the accessories list in the Parts Section of this manual. The location of the venter on the outside wall shall be in accordance with ANSI Z223.1/NFPA 54, or in Canada with CAN/CSA-B149.1 and applicable local codes.

3.G Common Vent

WARNING

When an existing boiler is removed from a common venting system, the common venting system is likely to be too large for proper venting of the appliances remaining connected to it.

Please read Section 3.A on page 11

At the time of removal of an existing boiler, the following steps shall be followed with each appliance remaining connected to the common venting system placed in operation, while the other appliances remaining connected to the common venting system are not in operation.

1. Seal any unused openings in the common venting system.
2. Visually inspect the venting system for proper size and horizontal pitch and determine there is no blockage or restriction, leakage, corrosion or other deficiencies which could cause an unsafe condition.
3. Insofar as it is practical, close all building doors and windows and all doors between the space in which the appliances remaining connected to the common venting system are located and other spaces of the building. Turn on clothes dryers and any gas burning appliance not connected to the common venting system. Turn bathroom exhausts, so they will operate at maximum speed. Do not operate a summer exhaust fan. Close fireplace dampers.
4. Place in operation the appliance being inspected. Follow the lighting instructions. Adjust thermostat so appliance will operate continuously.
5. Test for spillage at the burner opening after five minutes of main burner operation.
6. After it has been determined that each appliance remaining connected to the common venting system properly vents when tested as outlined above, return doors, windows, exhaust fans, fireplace dampers and any other gas burning appliance to their previous conditions of use.
7. Any improper operation of the common venting system should be corrected so the installation conforms with the National Fuel Gas Code, ANSI Z223.1. When re-sizing any portion of the common venting system, the common venting system should be re-sized to approach the minimum size as determined using the appropriate tables in Appendix G in the National Fuel Gas Code, ANSI Z223.1/NFPA 54.

3.G Événement Commun

AVERTISSEMENT

Lorsqu'une chaudière existante est retirée d'un système de ventilation commun, le système de ventilation commun est susceptible d'être trop grand pour une ventilation adéquate des appareils qui y restent connectés.

Lisez s'il vous plaît Section 3.A on page 11

Au moment du retrait d'une chaudière existante, les mesures suivantes doivent être prises pour chaque appareil toujours raccordé au système d'évacuation commun et qui fonctionne alors que d'autres appareils toujours raccordés au système d'évacuation ne fonctionnent pas:

1. Sceller toutes les ouvertures non utilisées du système d'évacuation.
2. Inspecter de façon visuelle le système d'évacuation pour déterminer la grosseur et l'inclinaison horizontale qui conviennent et s'assurer que le système est exempt d'obstruction, d'étranglement, de fuite, de corrosion et autres défaillances qui pourraient présenter des risques.
3. Dans la mesure du possible, fermer toutes les portes et les fenêtres du bâtiment et toutes les portes entre l'espace où les appareils toujours raccordés au système d'évacuation sont installés et les autres espaces du bâtiment. Mettre en marche les sècheuses, tous les appareils non raccordés au système d'évacuation commun et tous les ventilateurs d'extraction comme les hottes de cuisinière et les ventilateurs des salles de bain. S'assurer que ces ventilateurs fonctionnent à la vitesse maximale. Ne pas faire fonctionner les ventilateurs d'été. Fermer les registres des cheminées.
4. Mettre l'appareil inspecté en marche. Suivre les instructions d'allumage. Régler le thermostat de façon continue.
5. Faire fonctionner le brûleur principal pendant 5 min ensuite, déterminer si le coupe-tirage déborde à l'ouverture de décharge. Utiliser la flamme d'une allumette ou d'une chandelle ou la fumée d'une cigarette, d'un cigare ou d'une pipe.
6. Une fois qu'il a été déterminé, selon la méthode indiquée ci-dessus, que chaque appareil raccordé au système d'évacuation est mis à l'air libre de façon adéquate. Remettre les portes et les fenêtres, les ventilateurs, les registres de cheminées et les appareils au gaz à leur position originale.
7. Tout mauvais fonctionnement du système d'évacuation commun devrait être corrigé de façon que l'installation soit conforme au National Fuel Gas Code, ANSI Z223.1/NFPA 54 et (au) aux codes d'installation CAN/CSA-B149.1. Si la grosseur d'une section du système d'évacuation doit être modifiée, le système devrait être modifié pour respecter les valeurs minimales des tableaux pertinents de l'appendice F du National Fuel Gas Code, ANSI Z223.1/NFPA 54 et (au) les codes d'installation CAN/CSA-B149.1..

SECTION 4 Gas Connections

4.A Gas Supply and Piping

Follow this guideline checklist for the gas supply installation.

- Gas piping installation must be in accordance with the latest edition of ANSI Z223.1 and all local codes. In Canada, the installation must be in accordance with CSA-B149.1 and all local codes that apply.

Supply Pressure	Minimum	Maximum
Natural Gas	5.5 Inches WC	10.5 Inches WC
	(1.4 kPa)	(2.6 kPa)
LP Gas	10.0 Inches WC	13.0 Inches WC
	(2.5 kPa)	(3.2 kPa)

Table 3. Gas Supply Pressure Requirements

NOTE: The maximum inlet gas pressure must not exceed the specified value. The minimum value listed is for the purpose of input adjustment. Refer to **Table 4**

- Check the gas supply to be sure that it is the same as the gas indicated on the boiler's plate. This boiler, as shipped from the factory, is certified to operate within the altitude range indicated on the rating plate. If a field conversion to a different altitude range or different gas should be necessary, conversion parts are available. See Section 12.B on page 50 for part numbers.
 - Use the figures in Table 4 to size the gas inlet piping from the gas meter to the heater. Check all local codes for compliance before installing the heater.
 - A sediment trap (drip leg) must be installed ahead of the gas controls (**see Figure 11**). Fit the trap with a threaded cap which can be removed for cleaning.
 - Install a manual gas shutoff valve for service and safety. Do not use a restrictive gas cock. Flexible gas connectors, if used, must be CSA rated for the total input rating of the boiler.
 - Disconnect the boiler and its individual shutoff valve from the gas supply system during pressure testing of the system at pressures higher than 1/2 psi (3.45 kPa). If the test pressure is equal to or less than 1/2 psi (3.45 kPa), close the manual shutoff valve on the heater during the pressure test.
 - If the gas supply pressure is less than required, check for undersized pipe between the meter and the boiler, a restrictive fitting, or an undersized gas meter. Gas supply pressures to the heater are listed in Table 3.
- continued on next page.

CAUTION

Permanent damage to the gas valve will occur if the following procedures are not followed.

ATTENTION

Vous endommagerez la soupape de gaz si vous ne respectez pas les procédures suivantes.

Equivalent Distance From Gas Meter	Boiler Size					
	50	75	100	125	150	200
	Needed Pipe Size					
0-50ft 0-15m	1/2 1/2"	3/4 1/2"	3/4 1/2"	3/4 3/4"	3/4 3/4"	1 3/4"
50-100ft 15-30m	1/2 1/2"	3/4 1/2"	3/4 3/4"	1 3/4"	1 3/4"	1-1/4 1"
100-200ft 30-60m	3/4 1/2"	1 3/4"	1 3/4"	1 3/4"	1-1/4 1"	1-1/4 1"

***Note:** These figures are for **Natural Gas (.65 Sp. Gr.)**, and are based on **1/2" water column pressure drop**. For LP (1.5 Sp. 11" wc) and 1/2" water column drop. Check supply pressure with a manometer, and local code requirements for variations. Pipe fittings must be considered when determining gas pipe size. See National Fuel Gas Code or local code requirements for complete pipe sizing requirements.

Table 4. Gas Pipe Size Requirements*

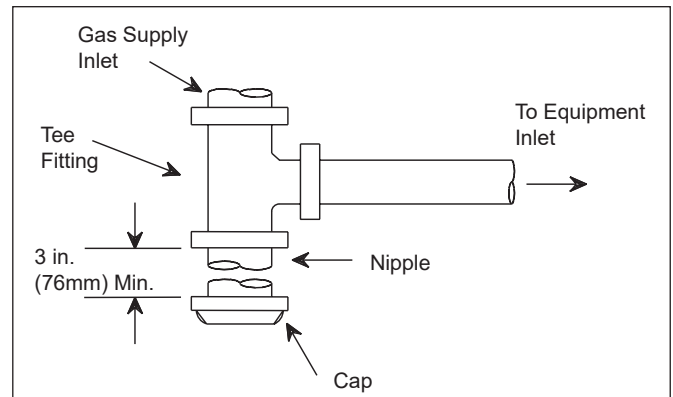

Figure 11. Typical design for a sediment trap/drip leg.

NOTE: The boiler and all other gas appliances sharing the boiler gas supply line must be firing at maximum capacity to properly measure the inlet supply pressure. Low gas pressure could be an indication of an undersized gas meter and/or obstructed gas supply line.

8. The correct manifold gas pressure is stamped on the rating plate. The regulator is pre-set at the factory, and normally requires no further adjustment.
9. Before operating the boiler, the complete gas supply system and all connections must be tested for leaks using approved methods for the authority having jurisdiction. Do not use an open flame.
10. Gas piping must be supported by suitable hangers or floor stands and not supported by the boiler.

CAUTION

Some leak test solutions (including soap and water) may cause corrosion or stress cracking. Rinse the piping with water after testing.

ATTENTION

Certaines solutions d'essai d'étanchéité (y compris l'eau et le savon) peuvent causer de la corrosion ou de la fissuration. Rincez les tuyaux à l'eau après l'essai d'étanchéité.

WARNING

The boiler is designed for use with either natural gas or LP gas, but only ships from the factory as natural gas. Conversion kits are available. **DO NOT ATTEMPT TO CONVERT THIS HEATER FOR USE WITH ANY OTHER TYPE OF FUEL.**

AVERTISSEMENT

Le unit est conçu pour être utilisé avec du gaz naturel ou du gaz LP, mais seulement des navires de l'usine comme gaz naturel. Des kits de conversion sont disponibles. **NE PAS ESSAYER DE CONVERTIR CET APPAREIL À UN AUTRE TYPE DE GAZ.**

4.C Special Precautions for LP Gas

LP (propane) gas is heavier than air and can therefore more readily collect or pool in enclosed areas if provision for proper ventilation is not made. Be sure to pay special attention to proper ventilation for LP gas. Locate boilers a safe distance from LP gas cylinders and filling equipment. In the United States, consult the "National Fuel Gas Code" (NFPA 54 / ANSI Z223.1, latest edition) or in Canada, the Natural Gas and Propane Installation Code (CAN/CSA B149.1), any local codes and fire protection authorities about specific installation restrictions in your area.

4.B LP Gas Conversion Kits

An LP (propane) conversion kit is available to field convert this boiler to use LP gas. The boiler's existing gas valve is converted by changing the valve's outlet regulator spring and resetting the outlet pressure regulator.

See Section 12.B on page 50 for kit part numbers.

The Gas Conversion Kit includes the following:

1. Gas valve regulator spring
2. Main Burner and Pilot Orifices
3. Installation Instructions
4. Conversion Label

SECTION 5 PUMP REQUIREMENTS

This boiler has a water tube design, and requires correct water flow for proper operation and long life.

NOTE: Field Supply System / Zone pump(s) for all models.

Size	Temperature Rise											
	15°F 8°C				20°F 11°C				25°F 14°C			
	Flow Rate		Headloss		Flow Rate		Headloss		Flow Rate		Headloss	
	gpm	l/s	ft	m	gpm	l/s	ft	m	gpm	l/s	ft	m
50	5.3	0.3	0.3	0.1	4.0	0.3	0.2	0.1	3.2	0.2	0.1	0.1
75	8.0	0.5	0.6	0.2	6.0	0.4	0.3	0.1	4.8	0.3	0.2	0.1
100	10.7	0.7	1.3	0.4	8.0	0.5	0.7	0.2	6.4	0.4	0.5	0.2
125*	13.3	0.8	2.2	0.7	10.0	0.6	1.3	0.4	8.0	0.5	0.8	0.2
150*	17.0	1.1	2.5	0.8	12.8	0.8	1.8	0.5	10.3	0.6	1.2	0.4
200*	22.8	1.4	5.0	1.5	17.0	1.0	3.1	0.9	13.7	0.9	1.9	0.6

*Models 125-200 ship with a low loss header with integral pump, so a separate boiler pump does not need to be sized or field-supplied.

NOTES:

1. Shaded area represents typical temperature rise.
2. gpm = water flow in gallons per minute.
3. l/s = water flow in liters per second.
4. ft = pressure drop (headloss) through the boiler in feet of water.

Table 5. Water Flow Requirements and Temperature Rise (boiler pump sizing reference)

5.A Pump Sizing with Low Loss Header and an Integral Pump

Models 125-200 are provided with a Low Loss Header to ensure that the boiler always receives adequate water flow for optimum efficiency, ease of installation and long life. The Low Loss Header, with its integral Boiler Pump, eliminates the need for by-pass piping because it allows the system flow and the boiler flow to be independent of each other without the cost and complexity of a typical Primary / Secondary type system. See Section 6.D

A Low Loss Header Kit is available for the model 50, 75, and 100 as an option for smaller systems that could benefit from its use. See SECTION 12.C

Headloss is only calculated through the individual zones for sizing of the system pump (s).

Zone Pump Size = GPM @Zone Feet of Headloss (See Table 6)

5.B Pump Sizing without a Low Loss Header

A typical residential pump creates enough GPM (gallons per minute flow) for the average, properly-designed, zone system for models 50 and 75. If a zone exceeds 100 equivalent feet of 3/4" pipe, a pump may not be large enough to overcome the resistance and ensure proper water flow through the boiler.

Sizing the boiler / system pump requires the headloss of the zone piping combined with the heat exchanger

NOTE: If small zones are being installed with large boilers, a buffer tank will help reduce short cycling of the boiler and will enhance system performance.

Model Size	GPM	Equivalent Feet of 3/4" Type M Copper	Feet of Head Loss
50	5	75	4.9
		100	6.5
75	7.5	75	10.3
		100	13.8
100	10	75	17.6
		100	23.5

Table 6. Equivalent Feet and Head Loss (zone pump sizing reference)

headloss. Use Table 5 and 6 to approximate the head loss for each zone and ensure the pump selection is adequate. Compare to the manufacturer's pump curve to ensure sufficient flow for the boiler.

Zone Pump Size = GPM @Zone Feet of Headloss (See Table 6) + Boiler Headloss (See Table 5).

Primary/Secondary systems and boilers with LLH systems can be used to avoid needing larger system pumps.

SECTION 6 WATER CONNECTIONS

6.A Water Piping

NOTE: This boiler must be installed in a closed pressure system with a minimum of 12 psi (82.7kPa) static pressure at the boiler.

Section 6.D on page 21 shows typical plumbing installations. Be sure to provide unions and isolation valves at the boiler inlet and outlet so it can be isolated for service. Check local codes for specific plumbing requirements before beginning the installation.

An ASME pressure relief valve is supplied with these boilers, and is pre-set at 30 PSI. The valve outlet piping should be discharged to a drain and must be piped to discharge near the floor. It cannot have a threaded end at its termination point nor be of a closed circuit design.

A pressure reducing valve (automatic feed) must be used to maintain the system at constant proper pressure. Supply properly installed purge valves to eliminate air from each circuit.

A drain valve is installed on the lower right side of the boiler and is used for draining the unit for service. If the boiler is being drained so that it will be left in a space that may freeze, it is critical to remove the two lower plugs from the left side of the heat exchanger. See Section 9.E on page 40 This is the only way to ensure all the water is out of the heat exchanger.

Be sure at least one air elimination device is installed in the system to eliminate trapped air from the system.

Hot water piping should be supported by suitable hangers or floor stands, NOT by the boiler. Due to expansion and contraction of copper pipe, consideration should be given to the type of hangers used. Rigid hangers could transmit noise through the system caused by the piping sliding in the hangers.

A properly sized expansion tank must be included in the system.

6.B Oxygen Permeable Systems

This boiler must not be directly connected to a heating system utilizing oxygen permeable tubing. Provide a water-to-water heat exchanger between systems to prevent corrosion of ferrous metals such as the boiler's piping, wet walls, etc. Air elimination devices are not sufficient protection and corrosion damage is not covered under the limited warranty.

6.C Anti-freeze

Non-toxic HVAC anti-freeze may be added to the hydronic system provided the concentration does not exceed 50%, and the anti-freeze contains an anti-foaming agent and rust inhibitor. Follow the anti-freeze manufacturer's recommendations for yearly or biannual replacement of system anti-freeze. Never use toxic automotive anti-freeze in a boiler system.

The use of an anti-freeze will reduce the heat transfer capabilities of the water.

NOTE: The use of an anti-freeze will reduce the heat transfer capabilities of the water.

NOTE: Not all manufacturer supplied pumps are capable of maintaining the reduced temperature rise required with glycol concentrations greater than 35%. If glycol concentrations required are greater than 35% a field supplied pump should be used.

CAUTION

Different glycol products may provide varying degrees of protection. Glycol products must be maintained properly in a heating system, or they may become ineffective. Consult the glycol specifications, or the glycol company, for information about specific products, maintenance of solutions, and set up according to your particular conditions.

NOTE: The minimum return water temperature of the unit, in order to avoid condensation in the vent, is 130°F. The unit's control is equipped to protect against low temperatures, however the pumps must be installed and wired properly for this feature to function. The system pumps must be wired to the system pump terminals, and a boiler pump must be installed and wired to the boiler pump terminal (models 125 - 200 are built with LLH / boiler pump systems that are wired at the factory). See Figure 28 on page 27. If the system is not setup this way, condensation may occur which could damage venting systems.

6.D Typical Plumbing Diagrams

These diagrams are only meant as a guide. All components or piping required by local code must be installed.

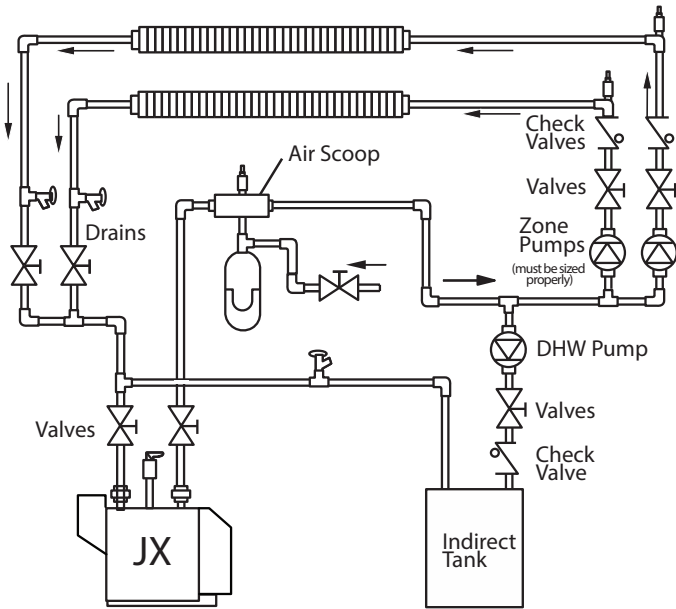

Figure 12. Zone Pumps and DHW
For models 50 - 75

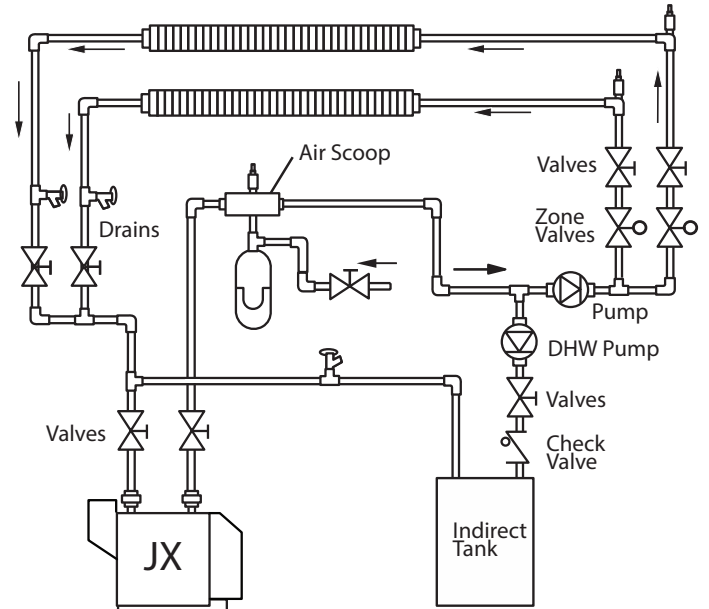

Figure 13. Zone Valves and DHW
For models 50 - 75

NOTE: Pumps are sized for Boiler & Zone Headloss. See SECTION 5

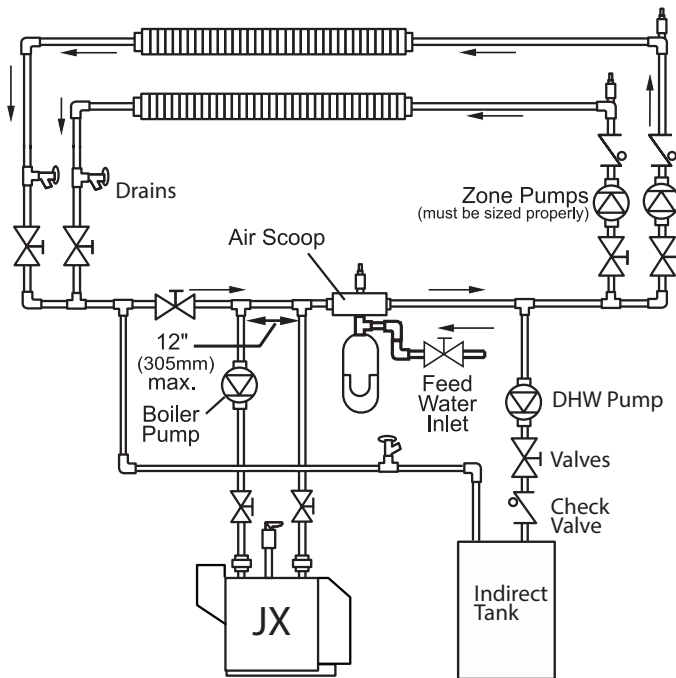

Figure 14. Primary Secondary, Multi-Zone Pump System and DHW
For model 100

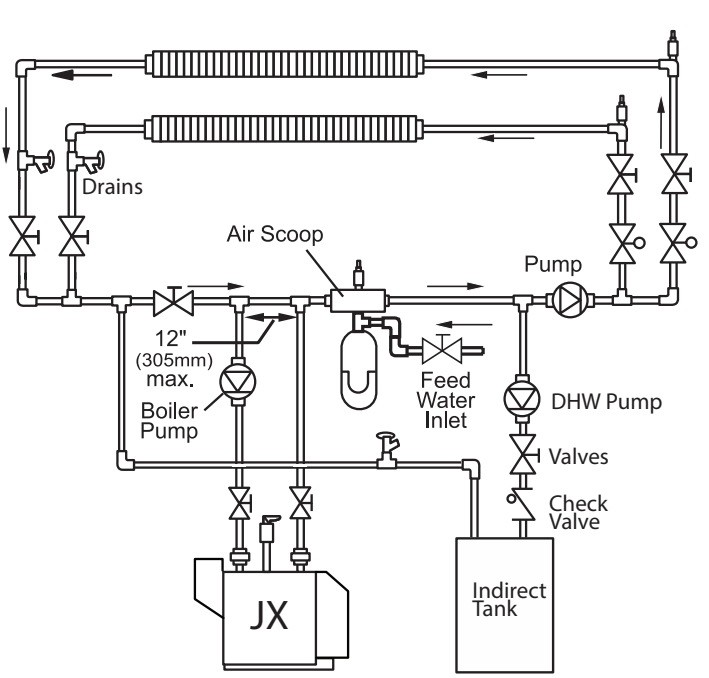
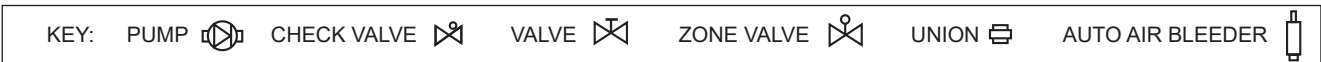

Figure 15. Primary Secondary, Multi-Zone Valve System and DHW
For model 100

NOTE: Primary Secondary piping option OR Low Loss Header are required for the model 100.



Typical Plumbing Diagrams (continued)

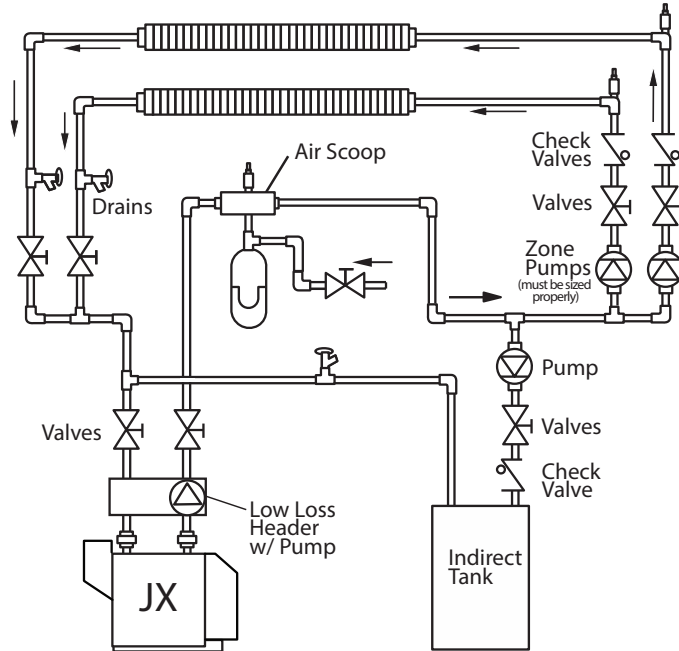

Figure 16. Low Loss Header with Zone Pumps and DHW

Low Loss Header is standard on models 125, 150, and 200 and Optional for models 50, 75, and 100.

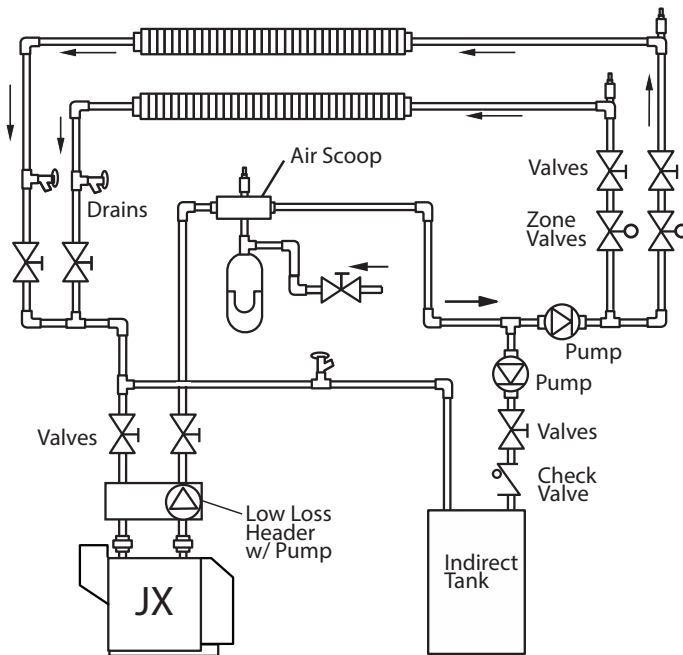

Figure 17. Low Loss Header with Zone Valves and DHW

Low Loss Header is standard on models 125, 150, and 200 and Optional for models 50, 75, and 100.

KEY:	PUMP	CHECK VALVE	VALVE	ZONE VALVE	UNION	AUTO AIR BLEEDER
------	------	-------------	-------	------------	-------	------------------

SECTION 7 ELECTRICAL AND WIRING DIAGRAMS

7.A Safety Warnings

WARNING

This unit must be electrically grounded in accordance with the requirements of the authority having jurisdiction or, in the absence of such requirements, with the latest edition of the National Electrical Code, ANSI/NFPA 70, in the U.S. and with the latest edition of CSA C22.1 Canadian Electrical Code, Part 1, in Canada. Do not rely on the gas or water piping to ground the metal parts of the boiler. Plastic pipe or dielectric unions may isolate the boiler electrically. Service and maintenance personnel, who work on or around the boiler, may be standing on wet floors and could be electrocuted by an ungrounded boiler. Electrocution can result in severe injury or death.

NOTE: All internal electrical components have been pre-wired. No attempt should be made to connect electrical wires to any other location except the terminal blocks and line voltage hanging leads / pigtail.

NOTE: Single pole switches, including those of safety controls and protective devices, must not be wired in a grounded line.

NOTE: All units with manufacturer recommended and supplied boiler pumps may be powered using the supplied voltage.

CAUTION

Label all wires prior to disconnection when servicing controls. Wiring errors can cause improper and dangerous operation.

ATTENTION

Au moment de l'entretien des commandes, étiquetez tous les fils avant de les débrancher. Les erreurs de câblage peuvent nuire au bon fonctionnement et être dangereuses.

CAUTION

Verify proper operation after operation servicing.

ATTENTION

S'assurer que l'appareil fonctionne adéquatement une fois l'entretien terminé.

WARNING

No Power to be applied to terminals 10-12 of TB1. Sensor Connections Only!

7.B Main Power, 120V / 15 Amp Circuit

This boiler has a set of wires for the main power connection. They are located in the area between the control bezel and the conduit anchor plate. The black lead for 120V(H), the white for 120V(N) and a green lead provides an earth ground. Appropriate service switches and circuit breakers need to be installed prior to the boiler based on national and local codes having jurisdiction. The size of the main power supply should be determined by Table 7. This table indicates the unit's Full Load Amperage (FLA), Maximum Overcurrent Protection and Minimum Circuit Ampacity (MCA). An overcurrent protection value should be selected based on these numbers.

	All Sizes	
	with Low Loss Header	without Low Loss Header
Voltage	120 V	120 V
FLA	0.70 A	0.20 A
MCA	0.90 A	0.25 A
MOP	15 A	15 A

Table 7. Boiler Electrical Data

7.C Outdoor Sensor

An optional outdoor sensor can be purchased for the use with the outdoor reset or WWSD with thermal targeting. See the Accessories List, Section 12.B on page 50. The sensor must be installed in a shaded area, preferably on the north side of the structure, and must be installed above the highest expected snow line.

To use the outdoor sensor for warm weather shutdown (WWSD) only: Connect sensor to WWSD and COM terminals. The control will then operate in Economy Mode settings using Thermal Targeting. It will also shut the boiler off at outdoor temperatures higher than the selected WWSD temperature.

To utilize Outdoor Reset: Connect the sensor to OAS and COM Terminals. The control will then operate based on the selected Outdoor Reset settings. It will also shut the boiler off at outdoor temperatures higher than the selected WWSD temperature.

Once the outdoor sensor is installed, see "8.C Sensor Programming" on page 33 for how to adjust the Outdoor Reset using the controller.

7.D Field Connections

This boiler has three Field Connection Terminals. TB1, TB2 and TB3 (TB3 is for optional equipment).

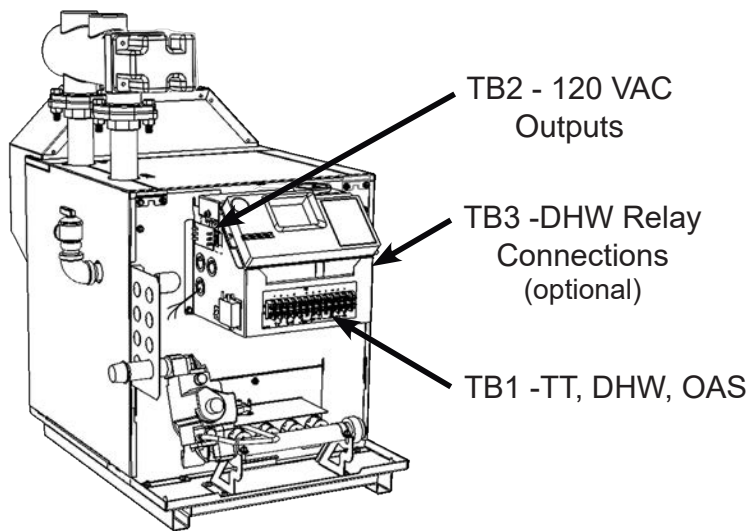

Figure 18. Terminal Block Locations

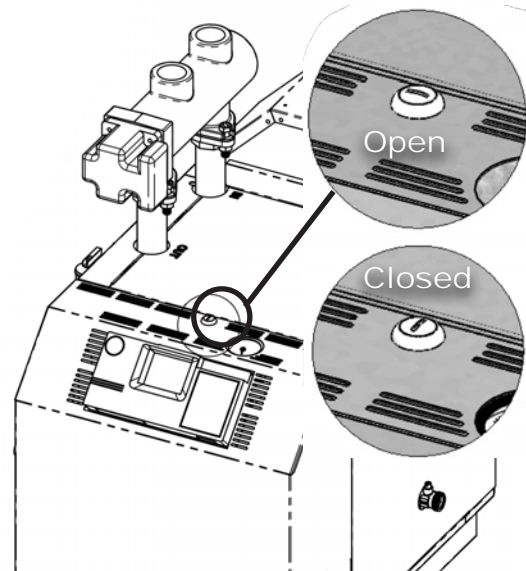

Figure 19. Unlocking the Cover

⚠ WARNING

No Power to be applied to terminals 10-12 of TB1.
Sensor Connections Only!

7.D.1 TB1 (Terminal Block 1) TT, DHW, OAS

7.D.1.a TT (Central Heat)

TT is for the end switch of a zone relay control system or direct thermostat connection. It controls the boiler to maintain the central heating. Do not connect directly to three wire zone valves. Always use an isolation relay or zone valve controller (see Figure 26 and Figure 27 on page 27).

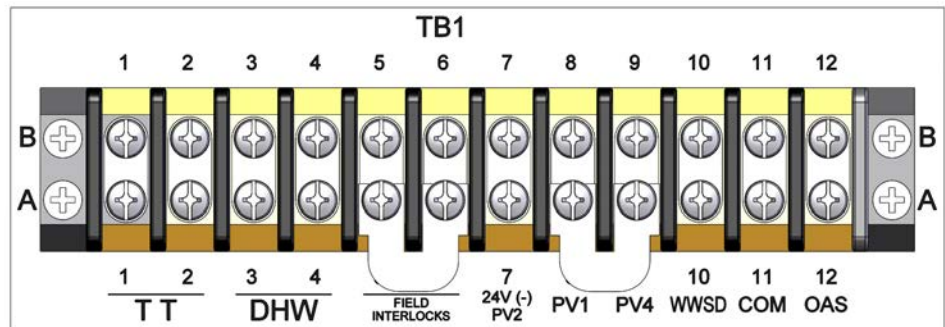

Figure 20. Field Connections (TB1)

7.D.1.b DHW

Either a tank aquastat or the leads from the optional DHW Relay Kit will control the boiler to the high limit setpoint. See SECTION 8 for functionality.

7.D.1.c Field Interlocks

Field Interlocks allow for auxiliary limits or LWCO. Breaking these connections prevents the boiler from operating. The LIMITS LED will flash while these connections are open.

7.D.1.d PV Terminals

PV1, PV2 and PV4 (PV Terminals) are for power venters or air make up equipment (See 7.E on page 26).

7.D.1.e WWSD + COM

10K Ω outdoor air sensor will allow the boiler to operate in economy mode with WWSD feature.

7.D.1.f OAS + COM

10K Ω outdoor air sensor provides outdoor reset control and warm weather shut down, based on control settings.

7.D.2 TB2 (for pumps and aux power)

7.D.2.a Boiler Pump

This terminal and the 120V(N) terminal will provide power to the boiler pump whenever the boiler is running. Use this to power the Low Loss Header (LLH) pump or a boiler pump in a Primary/Secondary application. If not using a LLH then this terminal can run power for a single zone or a zone valve system pump.

7.D.2.b SYS Pump

This terminal and the 120V(N) terminal will provide power to zone pumps or a zone valve system pump. This terminal cannot be used if the boiler does not have a dedicated boiler pump that is connected to the boiler pump terminal. When a system pump and dedicated boiler pump are piped and wired correctly, the control will energize the boiler pump only. Once the control detects high enough supply water temperature, the system pump will be energized. This feature helps protect the boiler from condensation due to low inlet water temperature.

7.D.2.c Aux Power

This terminal and the 120V(N) terminal provide constant high voltage to accessories such as power vent, combustion air and/or zone relay systems. Only the field supplied service switches or the main circuit breaker will interrupt the power to these terminals.

7.D.3 TB3 (for optional equipment)

DHW Kit - This terminal is only available if the accessory kit is purchased. It provides the boiler with the ability to drive a third pump (the DHW pump) for ease of installation.

7.D.3.a DHW Pump

These two terminals along with the GND terminal provide 120V during a DHW call. They are powered continually as long as DHW Aquastat terminals are closed.

7.D.3.b DHW Aquastat

These are 24VAC terminals that energize a relay when they are closed. The relay powers the DHW pump terminals and communicates with the boiler control to switch from heating settings to set point targeting.

Pump contacts rated to 5.8 FLA.

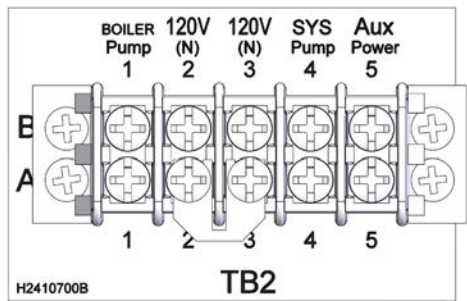
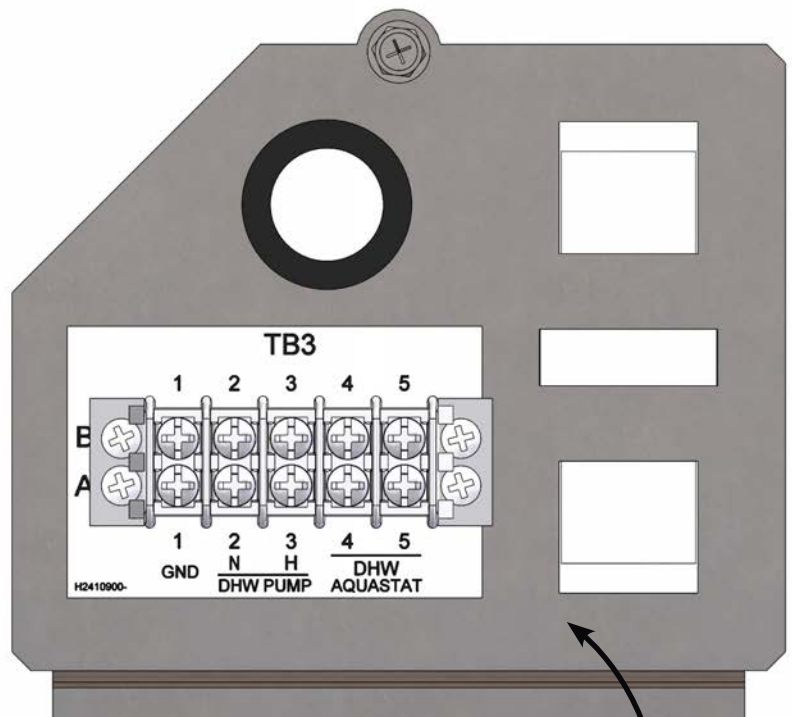

Figure 21. Field Connections (TB2)



DHW Pump contacts rated to 7.5 FLA.

Figure 22. Field Connections (TB3)

Photo of DHW Relay Kit.

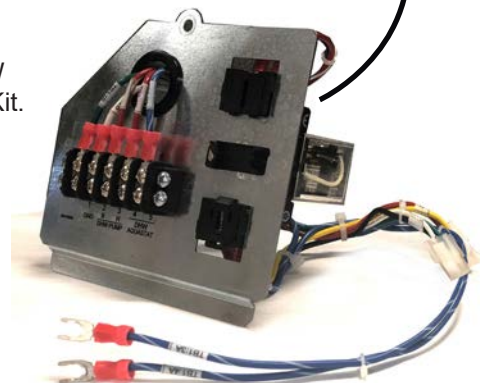

CAUTION

Do not exceed 15 Amp circuit. Additional circuits maybe required for pumps and accessories.

7.E Wiring Connections, Power Vent and Air

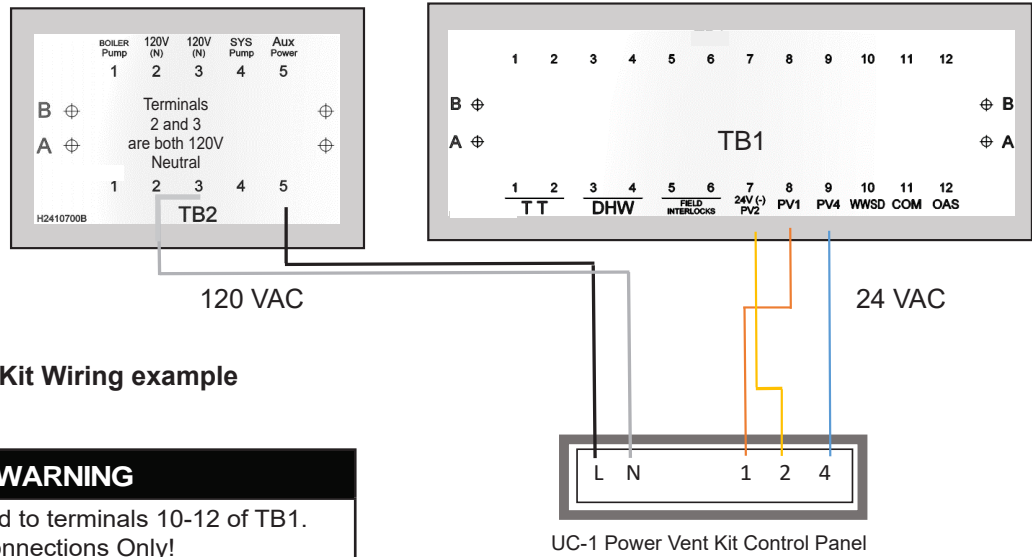

Figure 23. Power Vent Kit Wiring example

⚠ WARNING
 No Power to be applied to terminals 10-12 of TB1.
 Sensor Connections Only!

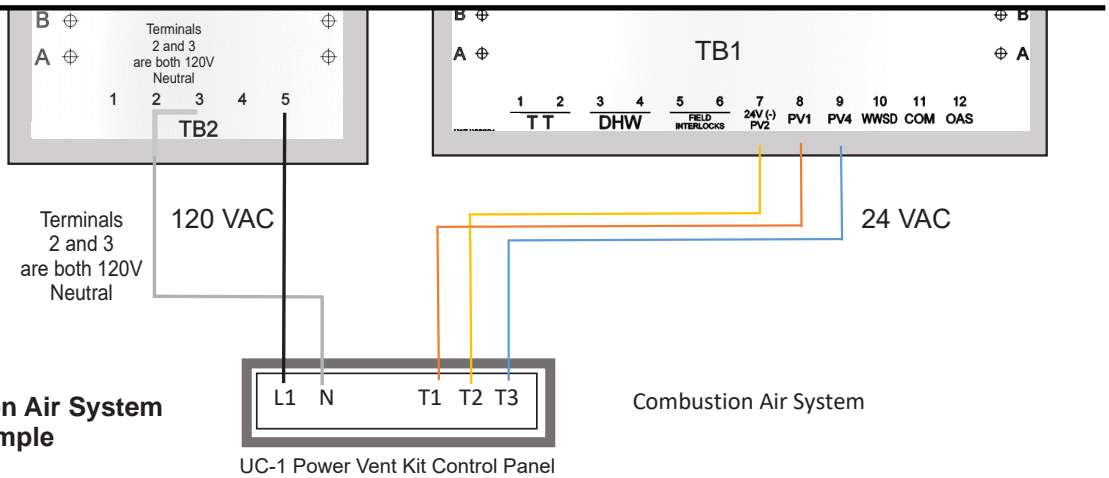

Figure 24. Combustion Air System wiring example

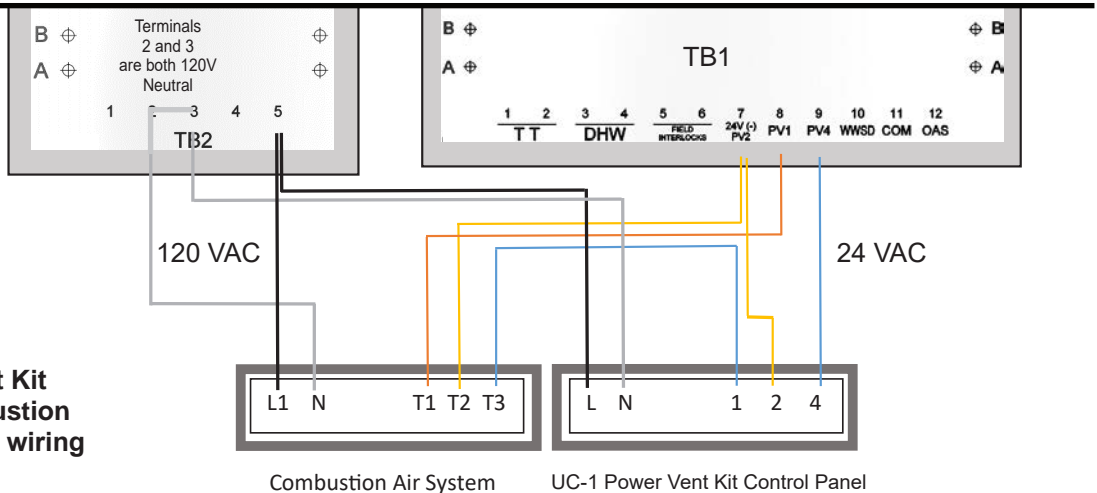

Figure 25. Power Vent Kit and Combustion Air System wiring example

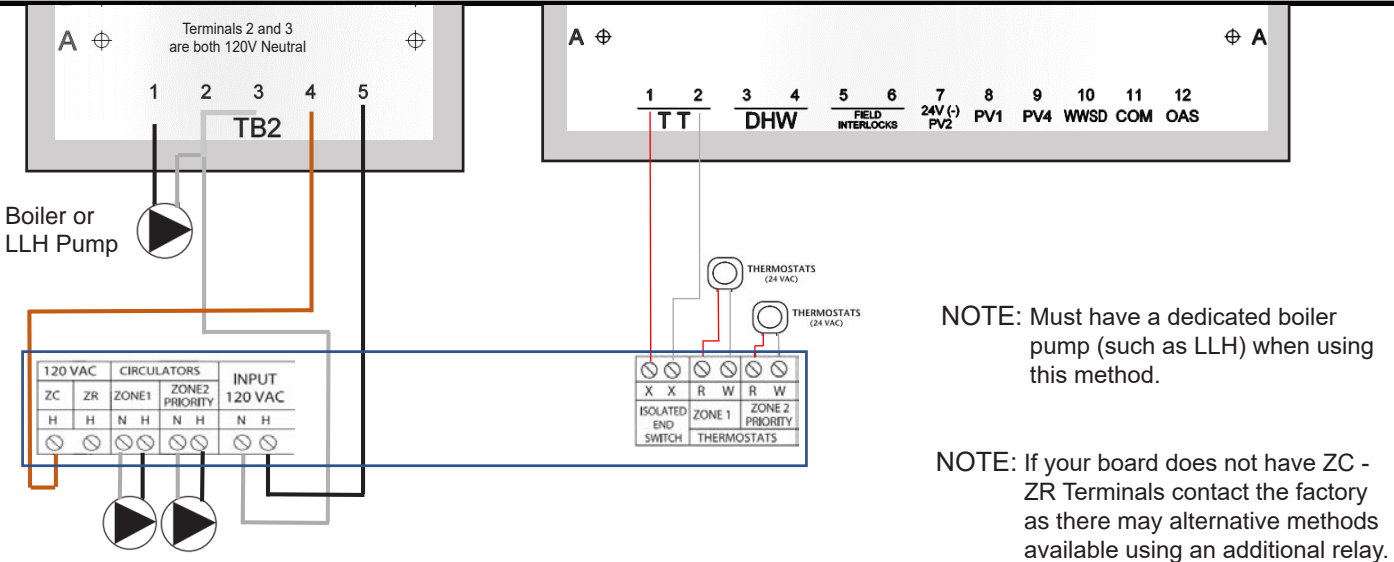
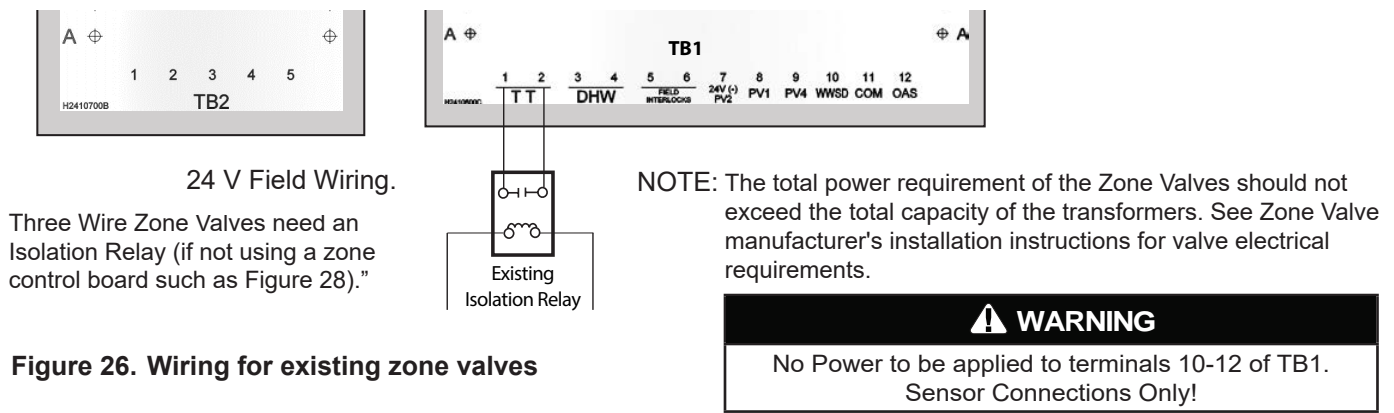

Figure 27. Typical Zone Pump Control Wiring for anti-condensing protection

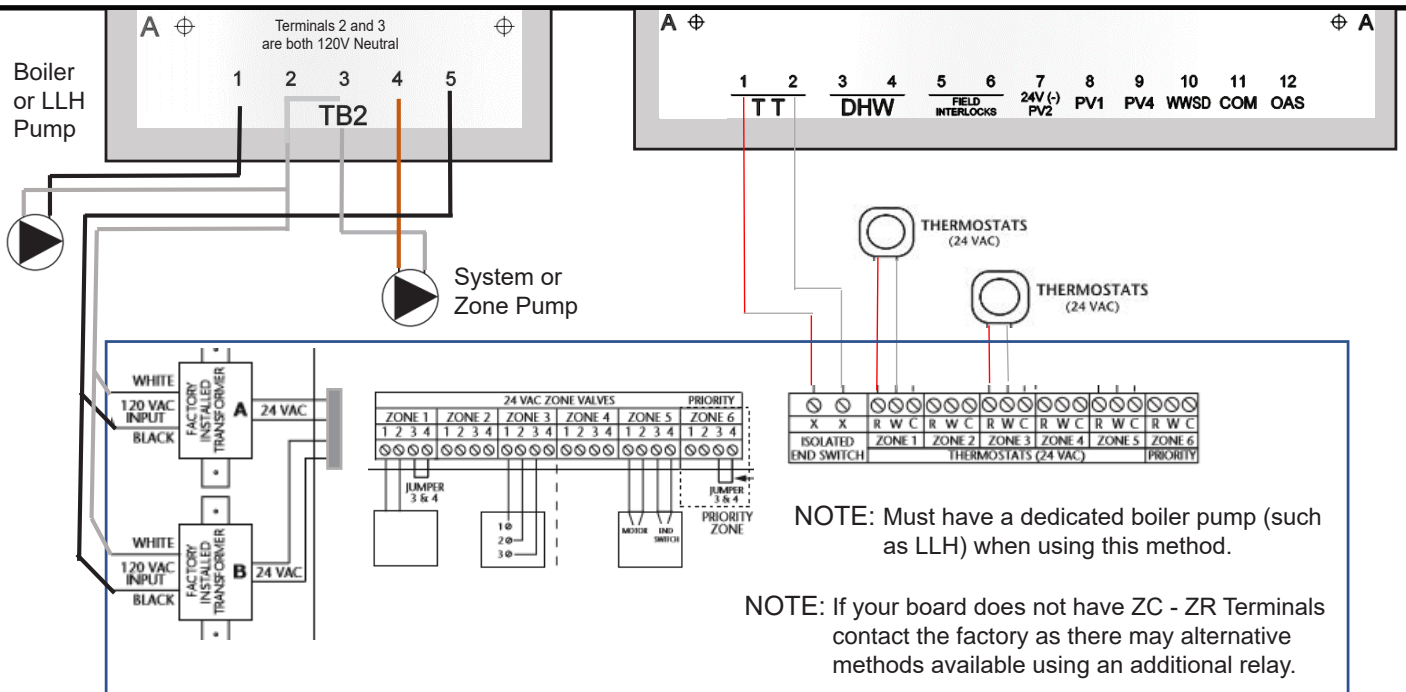

Figure 28. Typical Zone Valve Control Wiring for anti-condensing protection.

7.F Wiring Diagram

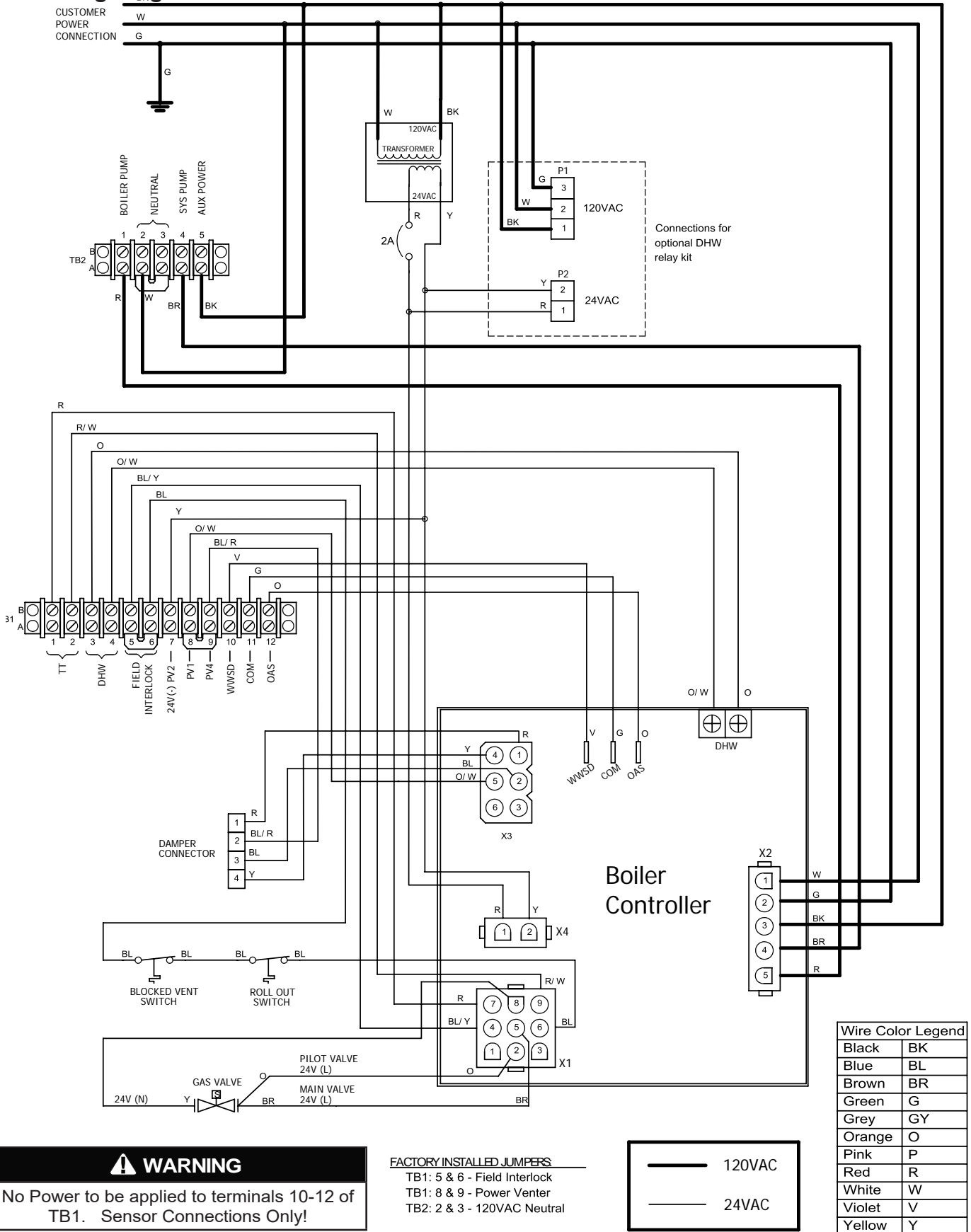

Figure 29. - Wiring Diagram

7.G Logic Diagram

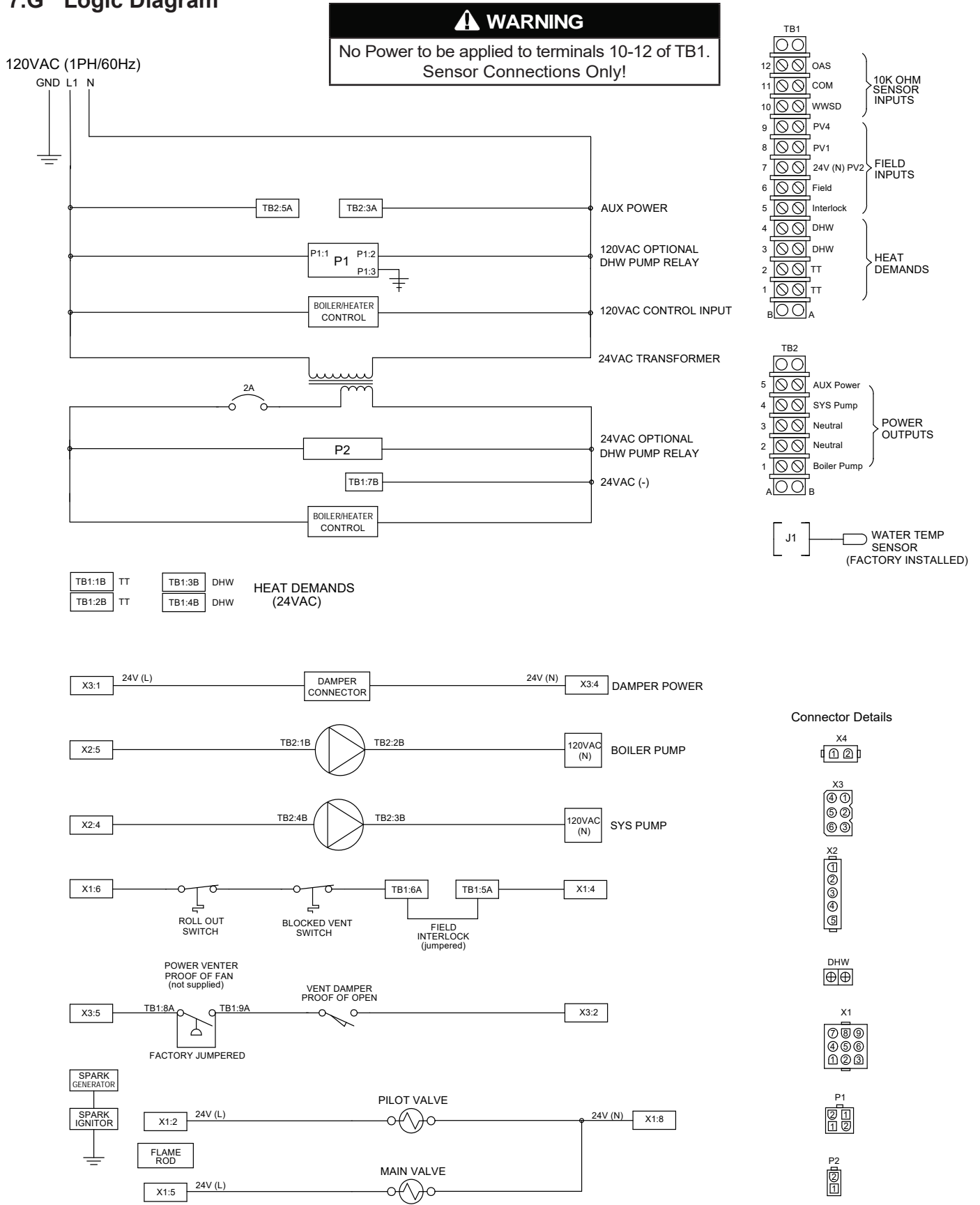

Figure 30. - Logic Diagram

SECTION 8 THE DIGITAL DASHBOARD

8.A Getting to know the Digital Dashboard.

NOTE: Most installations will not require setting anything within the Digital Dashboard.

The reasons for lifting the small transparent cover and adjusting the control are:

- Setting the low water cut-off to manual reset.
- Adjusting high limit to anything other than 190°F / 88°C.
- Installing an outdoor sensor for the purpose of setting the Reset Curve.
- Changing the temp readout from Fahrenheit to Celsius (or back to Fahrenheit).
- To change the economy settings.

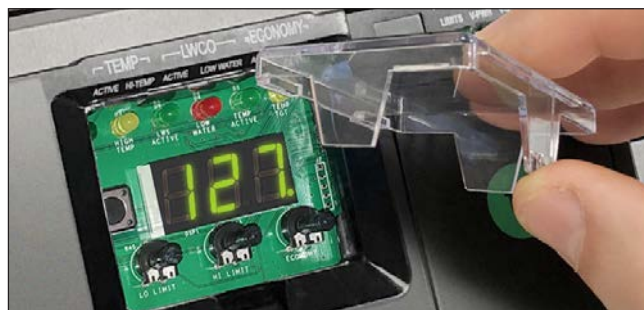

Figure 31. Remove the cover to make adjustments. (always re-position the cover when done)

⚠ WARNING

Dry your hands before removing the cover and touching the Dials or the Mode button. ALWAYS place the cover back into it's original position when you have completed your adjustments.

If you are the installer and have completed the installation (SECTIONS 1 thru 7 of this manual), the next step is to determine if your installation includes any of the **above listed items**. If Yes, then you will need to read THIS SECTION thoroughly and familiarize yourself with the Digital Dashboard. See Figure 32. Once you understand SECTION 8.A and you are familiar with the 3 dials and the Mode button, THEN continue to 8.B "Advanced Programing" on page 32

If the boiler has been installed and you want to adjust the HI LIMIT or the ECONOMY settings. Read SECTION 8.A.2 and 8.A.3 on this page. Be sure that you have a full understanding of what the Economy dial does before you move away from the Default setting of (1)

Under the removable clear cover, there are three (3) dials and one (1) button. (See Figure 32)

The green digital display in the middle shows the boiler outlet temperature.

8.A.1 The LO LIMIT Dial

(Advanced Programing)

This efficient hybrid copper/cast iron heat exchanger does not require a low limit setting, so 'LO LIMIT' has been disabled from the programing. This dial does still have it's secondary functionality for Advanced Programing. See Section 8.B on page 32.

8.A.2 The HI LIMIT Dial (Program Select)

The high limit is factory set at 190°F. To adjust, turn the HI TEMP dial until the desired setting is displayed (Range: 160°F - 220°F). Best operating range is 180°F - 200°F.

8.A.3 ECONOMY Dial (no outdoor sensor needed)

IMPORTANT NOTE: The Economy feature can be turned OFF ONLY FOR SERVICING of the boiler and cannot be left in the OFF position UNLESS AT LEAST ONE OF THE FOLLOWING CONDITIONS IS TRUE:

- Control is functioning in Reset Ratio Mode. See 8.C.3
- An external energy management system is installed that reduces the boiler water temperature as the heating load decreases.
- This boiler is not used for any space heating.
- This boiler is part of a modular or multiple boiler system having a total input of 300,000 BTU/hr or greater.

The Economy feature is factory set at one (1). See Figure 34 on page 35. Economy Mode (Thermal Targeting) works without need of an outdoor sensor. For most installations in colder northern regions, the Economy dial will be set to 1 or 2. If this installation is in a warmer climate and in a highly efficient home with a sufficient system of heat emitters, then the settings of 3 or higher can be used. The control is designed with algorithms that keep track of the time intervals between the calls for heat (the boost intervals) and system temperature that is needed to achieve all of the heat demands (the boosted temperature). For more detail please see "Advanced Programing" on page 32

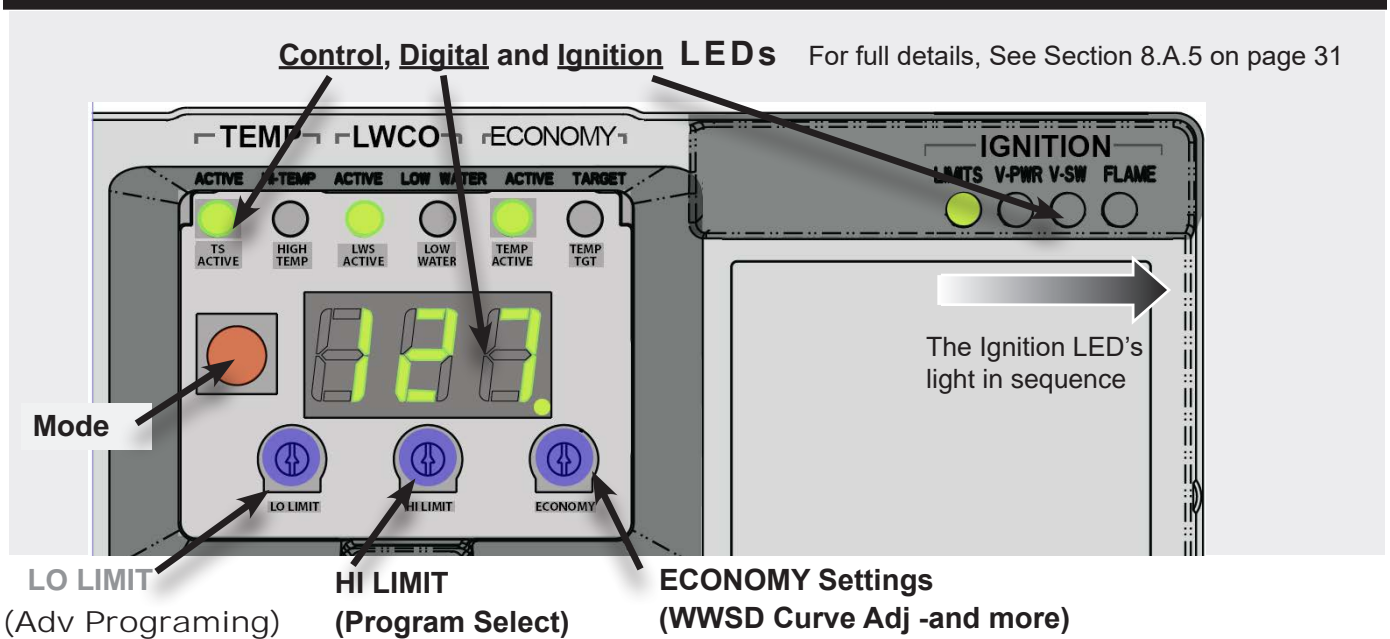

Figure 32. The Dials and Indicators of the Digital Dashboard

8.A.4 Mode

The Mode button performs various functions when testing, viewing, and selecting the settings of your boiler. See Sections "Advanced Programing" on page 32 and "Sensor Programming" on page 33

8.A.5 Control LEDs See Figure 32

8.A.5.a TS ACTIVE (TEMP)

Indicates that the control is powered and that the temperature function is active.

8.A.5.b HIGH TEMP

Illuminates when the boiler water temperature reaches the high limit setting. The control will prevent the burner from operating until the temperature drops below the on differential. The Control prevents burner operation while this LED is on.

8.A.5.c LWS ACTIVE (LWCO)

Indicates that the low water cut-off (LWCO) function of the Control is active.

IMPORTANT NOTE: If the sensor installation has been modified to a single function sensor well, this LED will not illuminate indicating that the control is not providing low water cut-off functionality. Always use a dual purpose temp and LWCO sensor well.

8.A.5.d LOW WATER

⚠ WARNING

Allow the boiler to fully cool before adding water.

Indicates that the boiler is in a low water condition. The control will prevent burner operation during this

condition. The control has been programmed to provide shutdown protection in the event a low water condition is detected. When water is detected, the condition will return to normal. If LWCO condition will not clear, see Section 11.D.1 on page 45 Also See 8.B.2 on page 32 for more info.

8.A.5.e TEMP ACTIVE (ECONOMY)

Indicates that the Thermal Targeting function is active and the control will reduce boiler temperature to conserve fuel. The Economy feature is activated using the ECONOMY dial.

8.A.5.f TEMP TARGET

When the Economy feature or Outdoor Reset is active, the control continually sets target temperatures below the high limit setting to maximize fuel efficiency. When the boiler water reaches the target temperature, the LED illuminates and the burner will shut down. The boiler water will continue to circulate and heat the house as long as the thermostat call continues. The LED will stay lit until the boiler temperature drops below the differential set point at which point the boiler will be allowed to fire again.

NOTE: This LED illuminates regularly during normal boiler operation.

8.A.6 Digital LEDs See Figure 32

The Digital Display is the numeric display in the middle of the control and presents the numeric value of all temperatures and setpoints and advanced programing settings.

8.A.7 Ignition LEDs See Figure 32

8.A.7.a LIMITS

Illuminates on a call for heat to indicate the limits are satisfied. Limits may include flame rollout, spill switch, field interlock terminals (secondary low water cutoff etc). If the limits are open the LED will blink.

8.A.7.b V-PWR

Indicates power has been sent to the vent damper. The damper will open causing its end switch to close.

8.A.7.c V-SW

PV1 and PV4 have a factory installed jumper which needs to be removed when installing a Power Venter or other vent proving switches. The V-SW LED illuminates when the vent damper end switch and PV1 and PV4 terminals (such as power venter and/or air makeup air pressure switch) have closed, indicating the flue is clear. If the damper end switch or the air pressure switch fail to close in 30 seconds the LED will blink. When the problem is corrected it will automatically clear the fault and stay illuminated.

8.A.7.d FLAME

Illuminates when the pilot flame is lit. If pilot flame is not sensed within 75 seconds or if flame is lost the LED will blink.

8.B Advanced Programming

8.B.1 Fahrenheit or Celsius

The control has the ability to operate in Fahrenheit or Celsius. When operating in Celsius, a c will appear in the display next to the temperature whenever the temperature is below 100 degrees.

To change between Fahrenheit and Celsius.

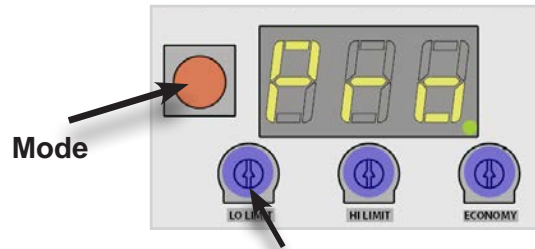

Figure 33. Advanced Programming

NOTE The 'Program Select' dial only stays on that parameter's display setting for 6 seconds before returning to Advanced Programming (Pro).

1. Turn the Advanced Programming dial to access the Program Mode – indicated in the display as Pro (See Figure 33)
2. Turn the HI LIMIT dial to select feature 2.
3. Press the Mode button to c for Celsius or F for Fahrenheit. See Table 8
4. When finished, turn the Advance Programming dial back to OFF or turn the HI LIMIT dial to the next setting (3) to adjust the next feature (See 8.B.2).

8.B.2 Low Water Cut-Off

8.B.2.a RESET, Manual or Automatic

The low water cut-off operation on the control can be set to operate in automatic (default) or manual RESET mode. The control will always shut-down the burner immediately when a low water condition is detected. If the low water condition is sustained for 30 seconds, the low water light will be either blinking or illuminated (depending on your reset mode), indicating that the control has locked out the burner.

Installation Programming Steps!

1	Advanced Programming Fahrenheit or Celsius? LWCO, Auto or Manual High Limit Differential	See 8.B.1 See 8.B.2 See 8.B.3	If you are NOT making changes to these settings, proceed to Step 2.
2	Install Outdoor Sensor Adjust WWSD Adjust Reset Ratio	See 8.C.1 See 8.C.2 See 8.C.3	If you're not using an outdoor sensor, or NOT making changes to these settings, proceed to Step 3.
3	Adjust Economy Dial	See 8.A.3	If you are using outdoor sensor and you've programmed your Reset Ratio, then skip the Economy dial and proceed to Step 4
4.	Set desired High Limit	See 8.A.2	Always finish with Step 4 to ensure the high limit is properly set.

When in the Automatic Reset Mode, the boiler will restart when the low water condition ends.

The manual reset feature meets CSD-1 requirements.

If in the Manual Mode, the control can only be reset by pushing the Mode button. To activate Manual Reset LWCO mode.

1. Turn the Advanced Programming dial to access the Program Mode – indicated in the display as Pro.
2. Turn the HI LIMIT dial to select feature 3.
3. Push the Mode button to A for Automatic Reset. See Table 8. Mode or b (lower case b) for Manual Reset Mode.
4. When finished, turn the Advance Programming dial back to OFF or turn the HI LIMIT dial to the next setting (9) to adjust the next feature (See 8.B.3).

8.B.2.b Testing Low Water Cut OFF

AUTO: To test LWCO while in Auto Reset mode, press and hold the Mode button for 10 to 30 seconds and the LOW WATER LED will illuminate solid red and the boiler will shut off. When you release the Mode button the light goes out and the boiler will re-fire. Auto Reset LWCO is working.

Manual: To test LWCO while in Manual Reset, press and hold the Mode button. The LED will illuminate solid red after 10 to 30 seconds, but continue to hold the Mode button for 60 seconds and the LWCO will shut down the boiler and the LOW WATER light will now flash red. Release and re-press the Mode button again to reset the LWCO and the boiler will restart.

8.B.3 High Limit Differential

This option allows for selecting a 10, 20 or 30 degree (Fahrenheit). These optional differential settings are subtractive from the HIGH LIMIT setting. When in DHW Mode the high limit differential is active. When in Economy mode the Thermal targeting differential is active.

To change the high limit differential.

1. Turn the Advanced Programming dial to access the Program Mode –indicated in the display as Pro.
2. Turn the HI LIMIT dial to select feature 9.
3. Push the Mode button to select a high limit differential of 10, 20, or 30 degrees.
4. When finished, turn the Advance Programming dial back to **OFF**.

Dial Setting	Feature	Options	Description	Default Setting
2	Fahrenheit or Celsius	F C	Degrees Fahrenheit Degrees Celsius	F
3	LWCO Manual or Automatic Reset	A b	Automatic Reset Manual Reset	A
8	Low Water Cut-Off Function	A	Low Water Cut-Off ON	A
9	High Limit Differential	10 20 30	10° Differential 20° Differential 30° Differential	30
dEF	Restore Factory Defaults	Y n	Restore Defaults Do Not Restore Defaults	n

Table 8. Dial Settings for Advanced Programs

8.C Sensor Programming

8.C.1 Outdoor Sensors

IMPORTANT NOTE: The outdoor sensor must be installed if Outdoor Reset Ratio is preferred over Thermal Targeting (Economy Mode) or if Warm Weather Shutdown is desired in either mode. Install sensor prior to setting the Warm Weather Shutdown or Reset Ratio. See Section 7.C on page 23

Outdoor Sensors are activated automatically when the sensor is wired. See Section 7.D.1 on page 24. When connected, Outdoor Reset overrides the Economy Settings. The display will toggle between boiler temperature (8 seconds) and outdoor temperature (2 seconds). If the sensor becomes damaged or disconnected, the control will automatically revert back to the Economy Settings. The display will no longer toggle outdoor temperature.

Before installation, determine the proper location for the sensor.

- Sensor should be mounted on the northern outside wall of the house, shielded from direct sunlight.
- Sensor should be installed high enough off the ground to protect it from accidental damage or drifting snow.
- Sensor should be installed away from potential heat sources such as exhaust fans, windows, or doors.

8.C.2 Setting Warm Weather Shutdown

The warm weather shutdown feature prevents the boiler from providing space heating when the outside temperature reaches a user-selected temperature. Available settings range from OFF or 40°-70°F. The boiler will still operate to satisfy a call for domestic hot water. The factory default setting for the warm weather shutdown is 70°F.

Wiring options are described in 7.C on page 23

To set the desired warm weather shutdown temperature: Press and hold the Mode button and simultaneously adjust the ECONOMY dial to the desired temperature setting.

To turn warm weather shutdown off - which will allow space heating regardless of outdoor temperature - press and hold the Mode button and simultaneously turn the ECONOMY dial fully counter-clockwise. Release the Mode button. After doing this, be sure to reset the ECONOMY dial to the correct setting. Any time the outdoor temp exceeds the WWSD setpoint, the display will toggle boiler temperature (8 seconds), outdoor temperature (2 seconds) and OFF (2 seconds). Boiler will not fire for a call for heat until the outside temperature drops below the WWSD setpoint.

8.C.3 Adjusting Outdoor Reset Ratio

The outdoor reset will regulate the boiler's temperature based on the temperature outside. On cold days, the boiler will run at higher temperatures to meet the heating load in the house. On warmer days, the boiler will run at lower temperatures to save energy while still meeting the heating needs of the house.

The Outdoor Reset uses a reset ratio method to control the boiler temperature. The reset ratio determines how much the boiler temperature is adjusted for changes in outdoor temperature. A reset ratio of 2.0 means that for each 1 degree drop in outdoor temperature, the boiler temperature will increase 2 degrees. See Table 9. Outdoor Reset has a boost function based on a 30 minute time interval using a 10 degree temperature boost. You can check the current target temperature at any time, by pressing the Mode button in four short intervals.

To set the desired outdoor Reset Ratio

1. Locate the Outdoor Design Temperature on the left side of the chart (the coldest outdoor temperature at design load conditions).
2. Locate the Boiler Target Temperature (the required supply water temperature at design load conditions) across from the Outdoor Design Temperature.
3. Follow the column up to the top of the chart to obtain the Reset Ratio setting.
4. Adjust the ECONOMY dial on the control to that Reset Ratio.

8.C.4 Thermal Boost Function

8.C.4.a Outdoor Reset

To ensure that the heating system always satisfies a call for heat, the control is equipped with a thermal boost feature. If in Outdoor Reset Mode, the control will have a fixed 30 minute Thermal Boost Interval.

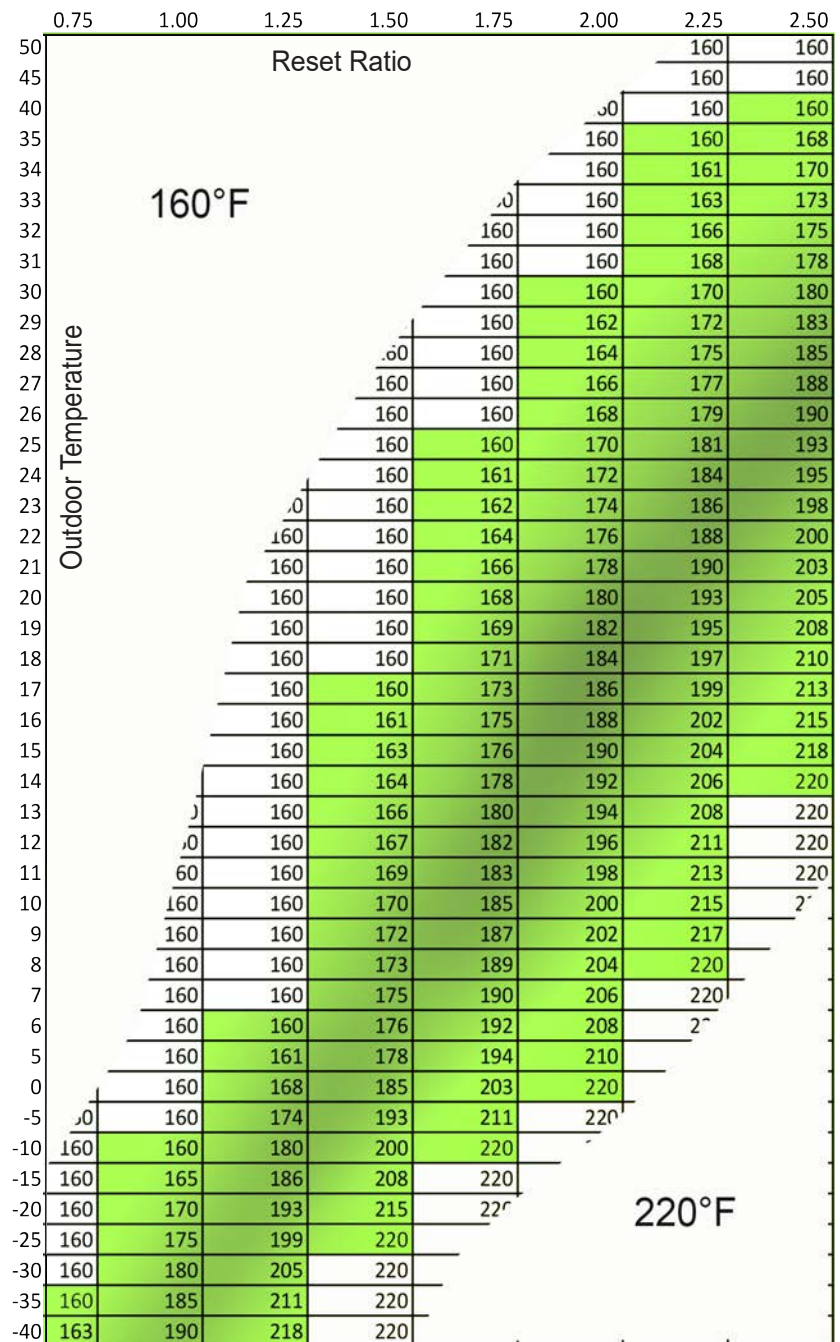

Table 9. Boiler Target Temperature

Example: If the thermostat is not satisfied thirty minutes after the boiler reaches the reset temperature, the control will boost the reset temperature by 10 degrees. It will continue to boost, until the call for heat is satisfied.

8.C.4.b Thermal Targeting

If in Economy mode, the Thermal Boost is increased to various intervals depending on your chosen setting. See Figure 34

Example: Thermal Targeting: Economy
Monitors thermostat activity to adjust the boiler temperature to the minimum output required to meet heating load.

Thermal Boost:
Boosts in 10 degree increments at timed intervals
Up to Hi- Limit setting.

Auto-Reduce:
Reduces 5 degrees with every new call
Reduces 5 degrees every 30 minutes of no demand

	Boost Interval	Boost Temp	On Differential
LO	10 min	10	20
1	15 min Factory Setting	10	20
2	20 min	10	20
3	25 min	10	20
4	30 min	10	20
5	35 min	10	20
HI	40 min	10	20

Figure 34. Economy Settings

8.D Restore Factory Default Settings

To restore advanced settings, to factory default settings (see Table 8 on page 33 for all program settings).

1. Turn the Advanced Programming dial to access the Program Mode – indicated in the display as Pro.
2. Turn the HI LIMIT dial to select feature dEF.
3. Push the Mode button to Y to reset all features to the default settings.
4. When finished, turn the Advance Programming dial back to OFF. ,
5. Reset Economy to 1 for default.
6. Reset HI LIMIT setting to 190 for default.

8.E View Current Settings

The Mode button has several functions when programming the boiler. When used by itself, it has the function of scrolling through and displaying the current settings.

Push the Mode button consecutively and you can stop on any one of the 5 current settings listed in Figure 36

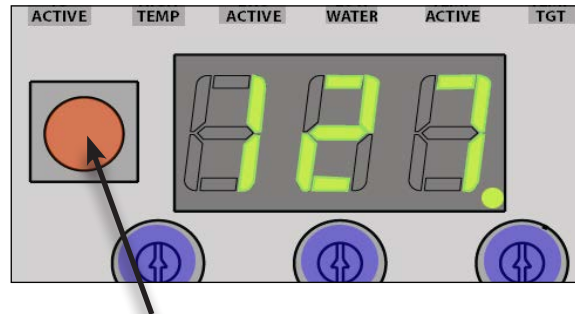
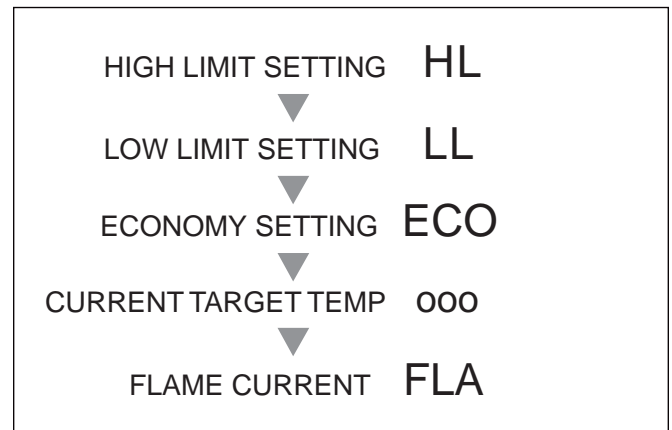

Figure 35. Mode Button



The display will return to the boiler temperature (default) if the Mode button is not pressed for 5 seconds.

Figure 36. Toggle through Current Settings

8.F DHW Functionality

During a call from an indirect water heater, the control will de-energize the System Pump contacts to heat only the indirect tank, ensuring an adequate supply of domestic hot water. The control will target the high limit setting and override Economy and Reset Ratio settings and WWSD settings. The control will re-energize the System Pump when the indirect tank is satisfied or if the boiler temperature reaches 170°F. This feature will allow the boiler to heat both demands from 151°F up to the high limit, until the calls are satisfied. If the indirect call continues for 45 minutes, the control will then override the priority function, energizing the System Pump to provide space heating.

SECTION 9 INITIAL STARTUP

9.A Filling the System

It is crucial to the efficient operation of the system that all air be removed from the circuit. For this reason, an air scoop and vent should be located close to the boiler outlet, and there should be a minimum distance between cold water feed and air elimination system.

1. When the system has been completely installed, and is free of leaks, open all automatic air vents and close all manual vents. Open the makeup water valve.
2. Close isolation valves. Operate purge and waste stations to purge each circuit one at a time, allowing a water makeup system to maintain pressure. During this purging process excess pressure can speed along the air removal but ensure pressure in the boiler doesn't exceed 30PSI or the relief valve will open.
3. Open all valves after all circuits have been purged.
4. Run the boiler pump for a minimum of 30 minutes with the boiler shut off. If using system pump terminals, the control won't start the pump(s) until the outlet exceeds 150°F. To cool purge these zones, turn off power and temporarily connect the lead to the Aux Power Terminal. Turn on power and purge the zones. Then after purging process is complete turn power off and return the lead to Sys pump terminals.
5. Open all strainers in the system, and check for debris.
6. Recheck all automatic air vents to ensure that they are open.
7. Setup boiler according to the procedures described in SECTION 8 and operate the system, including the pump, boiler, and radiation units, for one hour.
8. Close the water makeup valve and re-check all strainers for sediment or debris. Re-open the water makeup valve.
9. Ensure make up regulator is adjusted to maintain 12-15 PSI with matching charge in the properly sized expansion tank. Verify system pressure with the boiler pressure gauge before beginning regular operation.
10. Within 3 days of start-up, recheck and bleed all air vents using these instructions. It's critical that air elimination devices are functioning properly to prevent air locked zones and boiler damage.



Figure 37. Indicates a call for heat

⚠ WARNING

Carbon monoxide hazard. The vent damper must be fully open and the flue must be clear before the main burner fires. If the burner fires when the vent damper is not fully open or the flue is blocked, dangerous flue products such as carbon monoxide will escape into the house causing severe personal injury or death. The vent damper and flue must be checked for proper operation before allowing the system to operate.

9.B System Start Up (Sequence of Operation)

1. Raise the thermostat temperature to call for heat. The third decimal, lower right of the Control display will light indicating a call for heat.
2. The external limits will be confirmed. If the external limits are closed the green LIMITS LED will turn on. If the limits are not satisfied the green LIMITS LED will blink and the start up sequence will stop until the limits are satisfied and the green LIMITS LED is on.
3. Power is sent to the vent damper and the green V-PWR LED will light. The damper will begin to open. Power vent and air make up units will start if connected to PV1, PV2 and PV4.
4. The vent damper, power vents and air makeup units end switches will close. The green V-SW LED will light when the end switches close. If the switches do not close in 30 seconds the green V-SW LED will blink. The startup sequence will stop until corrected.

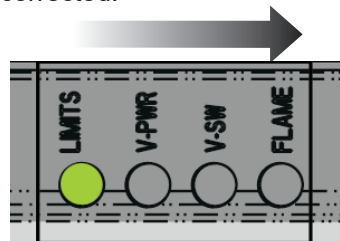

Figure 38. The Ignition LED's light in sequence

5. The spark will energize and the pilot valve will turn on. There will be an audible spark every 1 second until flame is sensed.
6. When pilot flame is sensed the green FLAME LED will turn on. If flame is not sensed in 75 seconds the pilot valve will de-energize, the spark will terminate, and the green FLAME LED will blink. After a 5 minute delay the sequence will retry at step 5. There will be an unlimited number of retries.

NOTE Always test for a complete electrical system ground. High voltage ignition can cause electrical interference if not properly grounded.

⚠ WARNING

Electrical shock hazard. The ignition circuit of the control can produce over 10,000 volts which can cause severe injury or death.

NOTE: Check for good quality pilot flame. See Section 9.C on page 38.

NOTE: Check the flame current and make the necessary adjustments to the pilot valve. See Section 9.C on page 38. Flame current should be set to a minimum of 1.0 micro amp.

7. When pilot flame is sensed, the main valve is energized.

NOTE: The limits, damper switch and pilot flame are continuously monitored during main valve operation. If any of these are opened or pilot flame is lost the main valve is immediately de-energized. A blinking green LED will indicate the cause of the shutdown (limits, v-sw, or flame).

8. Observe the main flame pattern on all burners. There should be minimal pulsing, unstable or lifting flame patterns. For any abnormal flame, check gas pressures and orifice alignment. If the gas pressures and orifice alignments are good, then the air shutter needs to be adjusted. On all burners exhibiting an abnormal flame, use a 5/16 inch wrench to loosen (do not remove) the air shutter locking screw. Slowly close or open the air shutter until a normal flame is observed then re-tighten its associated locking screw. If returning to factory setting is desired, measure one of two ways. 1-Measure. Factory setting is .75" from shutter to burner orifice mounting plate. 2-Use the Mini-Gauge to set to factory starting point. See Figure 40 and Figure 41.

9. After the startup, the ignition system safety device must be tested. To test, close the manual gas valve

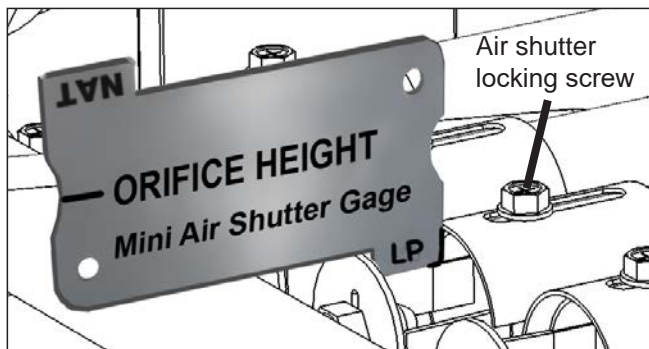

Figure 39. The Mini-Gauge (included with the installation kit) for Orifice Adjustment

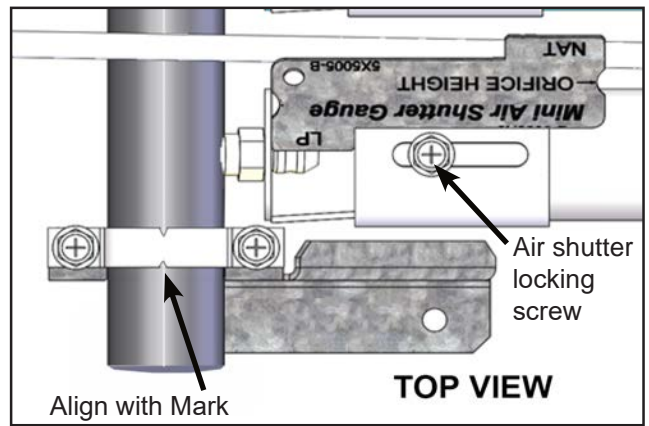

Figure 40. The Mini-Gauge for Shutter Adjustment

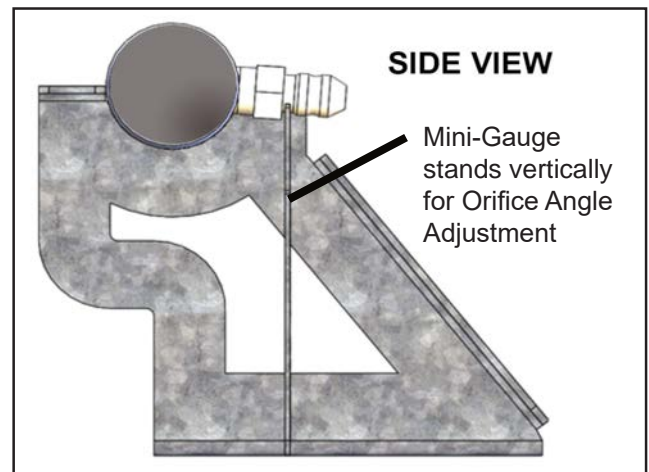

Figure 41. The Mini-Gauge for Orifice Adjustment

and verify that the burner flame is extinguished and the boiler continues to try to restart (continuous retry of pilot). You can then allow the boiler to restart by opening the manual gas valve.

- 10. Allow the boiler to operate until the target temperature or high temperature set point is reached. The yellow TARGET LED or the yellow HI-TEMP LED will light. The main burner and pilot flame will turn off. The FLAME LED will turn off.
- 11. The damper will begin to close and the V-PWR, V-SW and LIMITS LEDs will turn off.
- 12. Lower the room thermostat temperature to remove the call for heat. The third decimal, lower right of the control display will turn off

⚠ WARNING

Fire, explosion, or carbon monoxide hazard. Water damage can lead to unreliable operation or cause the control to malfunction which could lead to severe personal injury or death. Do not install the control module where it can get wet. Always replace the control if it gets wet or if it has any signs of water residue.

9.C Proper Pilot Flame

To view the pilot flame, the cover must be unlocked and removed. A properly adjusted pilot should have a blue, steady flame with an inner cone that engulfs 3/8" - 1/2" of the pilot ignitor sensor. See Figure 45 The pilot ignitor sensor should glow bright orange from the heat and the flame current should be 1.0 μ A to 1.8 μ A.

NOTE: To read flame current see Section "8.E View Current Settings" on page 35

If the pilot flame is over sized, orange in color, and blowing far beyond the pilot ignitor sensor then the pilot is over fired. The flame current will read outside of the nominal range of 1.0 μ A – 1.8 μ A and the pilot should be adjusted down using the valve's pilot adjustment screw, shown in Figure 42.

If the flame is small and the inner cone does not engulf the pilot ignitor sensor then the pilot is under fired. When the pilot is under fired the pilot ignitor sensor does not glow bright orange. The flame current will read below 1.0 μ A and should be adjusted up to a value between 1.0 μ A and 1.8 μ A.

NOTE: If the flame current reads below 0.8 μ A the control will continue to spark as it does not recognize an acceptable flame current.

NOTE: Flame Current reading will remain in the display for 30 seconds to allow for pilot adjustment.

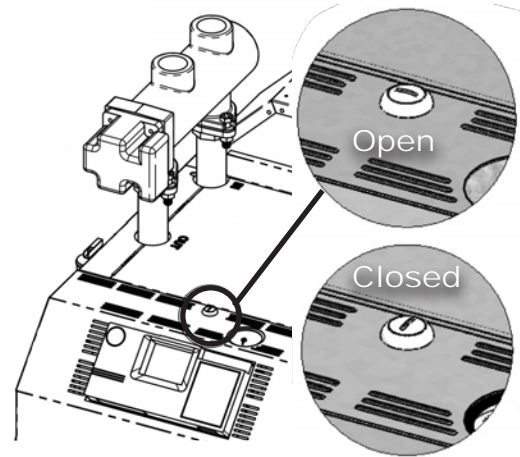

Figure 43. Unlocking the Cover

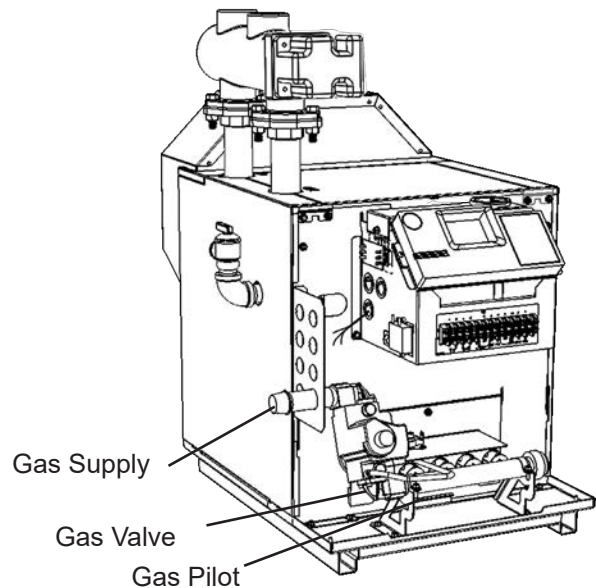

Figure 44. Without the Front Cover

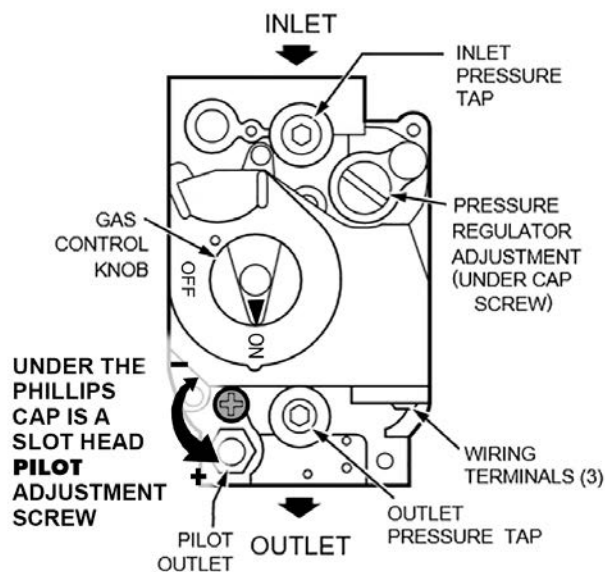

Figure 42. The Gas Valve Adjustment

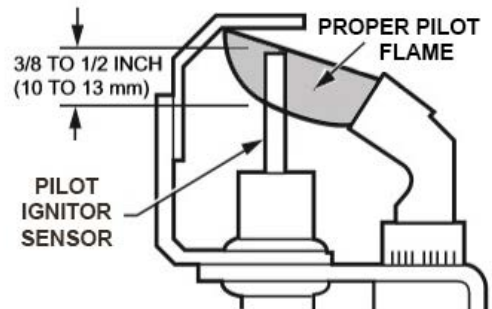

Figure 45. Pilot Flame Example

9.D Lighting Instructions Decal

Lighting instructions are located on a label on the right side of the boiler, and are depicted in this section of the manual.

For details on starting this boiler and what the digital dashboard is showing you as the boiler is started, please see Sections 8.A on page 30 and 9.B on page 36

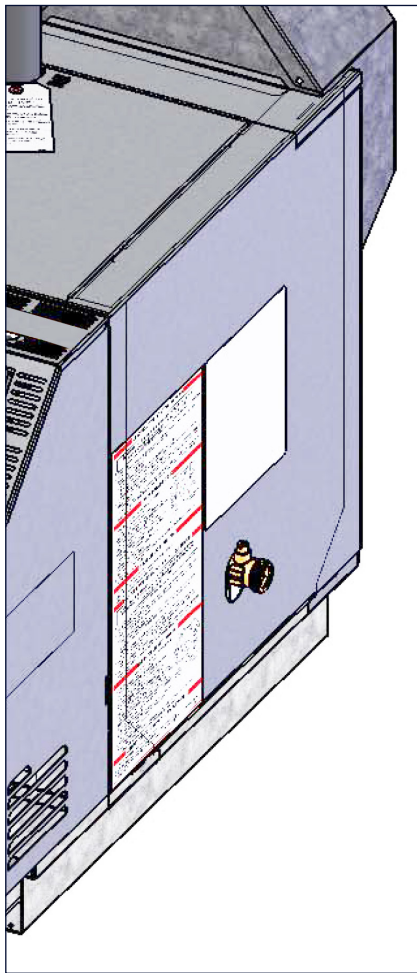

Figure 46. Located on side panel

FOR YOUR SAFETY READ BEFORE OPERATING

WARNING: If you do not follow these instructions exactly, a fire or explosion may result causing property damage, personal injury or loss of life.

- A. This appliance is equipped with an ignition device which automatically lights the pilot. Do not try to light the pilot by hand.
- B. **BEFORE OPERATING** smell all around the appliance area for gas. Be sure to smell next to the floor because some gas is heavier than air and will settle on the floor.
WHAT TO DO IF YOU SMELL GAS
 - Do not try to light any appliance.
 - Do not touch any electric switch; do not use any phone in your building.
 - Immediately call your gas supplier from a neighbor's phone. Follow the gas supplier's instructions.
 - If you cannot reach your gas supplier, call the fire department.
- C. Use only your hand to push in or turn the gas control knob. Never use tools. If the knob will not push in or turn by hand, don't try to repair it, call a qualified service technician. Force or attempted repair may result in a fire or explosion.
- D. Do not use this appliance if any part has been under water. Immediately call a qualified service technician to inspect the appliance and to replace any part of the control system and any gas control which has been under water.

OPERATING INSTRUCTIONS

1. STOP! Read the safety information above on this label.
2. Set the thermostat to lowest setting.
3. Turn off all electric power to the appliance.
4. Remove front access panel.
5. This appliance is equipped with an ignition device which automatically lights the pilot. Do not try to light the pilot by hand.
6. Turn gas control knob clockwise to "OFF"
7. Wait five (5) minutes to clear out any gas. Then smell for gas, including near the floor. If you smell gas, STOP! Follow "B" in the safety information above (to the left) on this label. If you don't smell gas, go to next step.
8. Turn gas control knob counterclockwise to "ON".
9. Place the front access panel back into its original position.
10. Set thermostat to desired setting.
11. Turn on all electric power to the appliance.
12. If the appliance will not operate, follow the instructions "To Turn Off Gas To Appliance" and call your service technician or gas supplier.

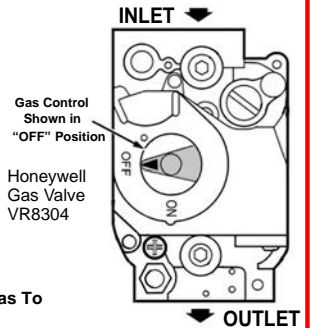

TO TURN OFF GAS TO APPLIANCE

1. Set the thermostat to lowest setting.
2. Turn off all electric power to the appliance if service is to be performed.
3. Remove front access panel.
4. Turn gas control knob clockwise to "OFF".
5. Place the front access panel back into its original position.

POUR VOTRE SÉCURITÉ, LISEZ AVANT DE METTRE EN MARCHÉ

AVERTISSEMENT: Quiconque ne respecte pas à la lettre les instructions dans la présente notice risque de déclencher un incendie ou une explosion entraînant des dommages, des blessures ou la mort.

- A. Cet appareil est muni d'un dispositif d'allumage qui allume automatiquement la veilleuse. Ne tentez pas d'allumer la veilleuse manuellement.
- B. **AVANT DE FAIRE FONCTIONNER**, reniflez tout autour de l'appareil pour déceler une odeur de gaz. Reniflez près du plancher, car certains gaz sont plus lourds que l'air et peuvent s'accumuler au niveau du sol.
QUE FAIRE SI VOUS SENTEZ UNE ODEUR DE GAZ
 - Ne pas tenter d'allumer d'appareil.
 - Ne toucher à aucun interrupteur; ne pas vous servir des téléphones se trouvant dans le bâtiment.
 - Appelez immédiatement votre fournisseur de gaz depuis un voisin. Suivez les instructions du fournisseur.
 - Si vous ne pouvez rejoindre le fournisseur, appelez le service des incendies.
- C. Ne poussez ou tournez la manette d'admission du gaz qu'à la main; ne jamais utiliser d'outil. Si la manette reste coincée, ne tentez pas de la réparer; appelez un technicien qualifié. Le fait de forcer la manette ou de la réparer peut déclencher une explosion ou un incendie.
- D. N'utilisez pas cet appareil s'il a été plongé dans l'eau, même partiellement. Faites inspecter l'appareil par un technicien qualifié et remplacez toute partie du système de contrôle et toute commande qui ont été plongés dans l'eau.

INSTRUCTIONS DE MISE EN MARCHÉ

1. ARRÊTEZ ! Lisez les instructions de sécurité sur la portion supérieure.
2. Réglez le thermostat à la température la plus basse.
3. Coupez l'alimentation électrique de l'appareil.
4. Retirer le panneau d'accès avant.
5. Cet appareil est muni d'un dispositif d'allumage automatique de veilleuse. Ne pas tenter d'allumer la veilleuse à la main.
6. Tourner le bouton de commande dans le sens des aiguilles d'une montre pour le mettre en position d'arrêt "OFF".
7. Attendre cinq (5) minutes pour laisser échapper tout le gaz. Reniflez tout le gaz. Reniflez tout autour de l'appareil, y compris près du plancher, pour déceler une odeur de gaz. Si vous sentez une odeur de gaz, ARRÊTEZ ! Passez à l'étape "B" des instructions de sécurité sur la portion supérieure (à gauche) de cette étiquette. S'il n'y a pas d'odeur de gaz, passez à l'étape suivante.
8. Tourner le bouton de commande dans le sens contraire des aiguilles d'une montre pour le mettre en position de marche "ON".
9. Réglez le thermostat à la température désirée.
10. Remettez le panneau d'accès avant dans sa position d'origine.
11. Mettez l'appareil sous tension.
12. Si l'appareil ne se met pas en marche, suivez les instructions intitulées "Comment couper l'admission de gaz de l'appareil" et appelez un technicien qualifié ou le fournisseur de gaz.

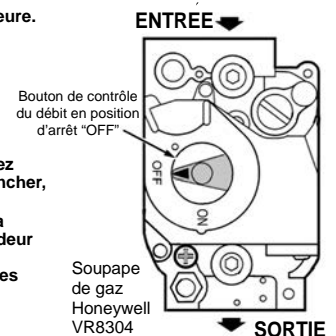

COMMENT COUPER L'ADMISSION DE GAZ DE L'APPAREIL

1. Réglez le thermostat à la température la plus basse.
2. Coupez l'alimentation électrique de l'appareil s'il faut procéder à l'entretien.
3. Retirer le panneau d'accès avant.
4. Tourner le bouton de commande dans le sens des aiguilles d'une montre pour le mettre en position d'arrêt "OFF".
5. Remettez le panneau d'accès avant dans sa position d'origine.

9.E System Shutdown

1. Turn off the main electrical disconnect switch.
2. Close all manual gas valves.
3. These boilers are certified for indoor use only and should not be subjected to freezing temperatures. When shutdown or during and extended power outage, component failure or other condition when freezing is likely, the boiler and system must be drained.

To completely drain the boiler,

- First drain the right side by opening the boiler drain.
 - Remove the PRV and related fittings.
 - Remove the top and left side panels.
 - Remove BOTH 1/2" plugs from the side of the boiler located at the bottom of the casting. Once the water is fully drained, reinstall the plugs and panels. See 10.A.3
4. Be sure to protect the piping in the building from freezing.

⚠ WARNING

This step must be performed by a qualified service technician.

SECTION 10 MAINTENANCE

10.A Removing the covers and panels

10.A.1 Access Cover Removal

To remove the front access cover simply turn the lock at the top center of the panel with a flat screw driver (slot indicates locking arm direction). Lift slightly and tip the top of the panel forward.

Reverse the process to reinstall.

⚠ WARNING

Do not leave this panel off in normal operation. High voltage and temperatures could cause a hazardous condition

10.A.2 Flue Collector Access

After removing the front access cover, the top access panel can then be lifted up and off the unit. This will expose the flue collector. Lift the flue collector using the handle in the front and slide it up and out. This will allow access to the top of the heat exchanger for cleaning.

Re-install the flue collector in reverse order, **ensuring that the front tabs contact the castings and the bottom flange are inserted into the front heat exchanger baffle.** Return the top panel by inserting the rear edge first at approximately a 15-degree angle then dropping the front. There is a slight spring force pushing forward.

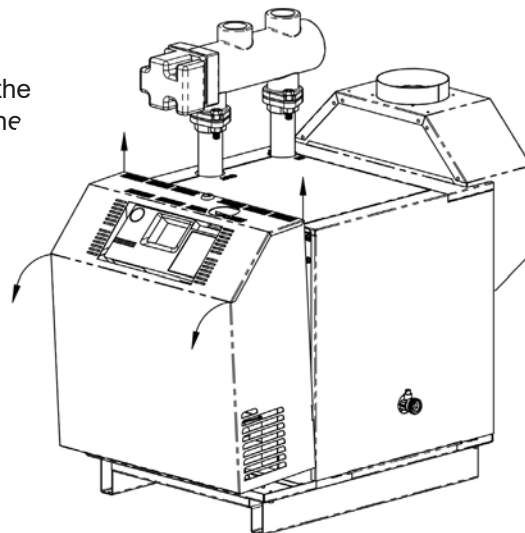

Figure 47. Remove the Front Cover

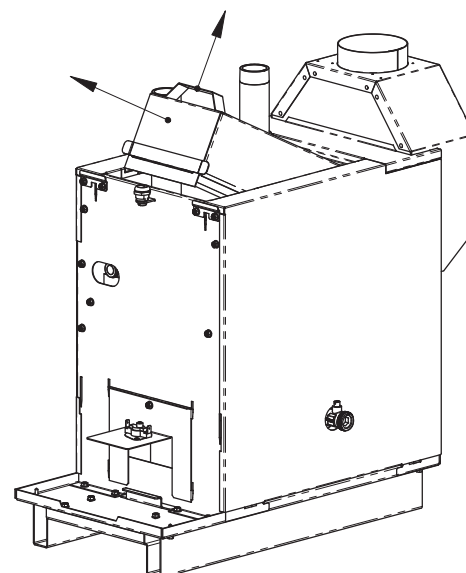

Figure 48. Lift Flue Collector Up and Out

10.A.3 Side Panel Removal

Remove the front access and the top as described previously. Drain the boiler and remove the drain valve and/or the PRV and associated fittings depending on the panel being removed. Then pull upward and inward slightly at the top inside flanges. These are spring type latches which will release as force is applied upward.

Reinstall by placing the panel at a slight angle to line up the bottom flange, tip it in until straight up, then push down until the upper spring catches.

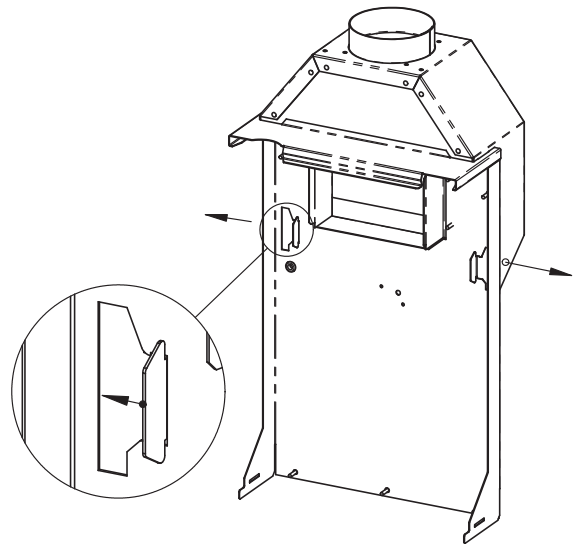
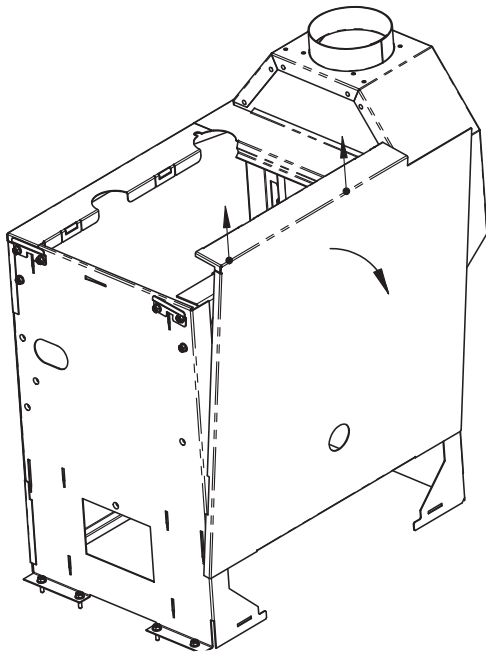
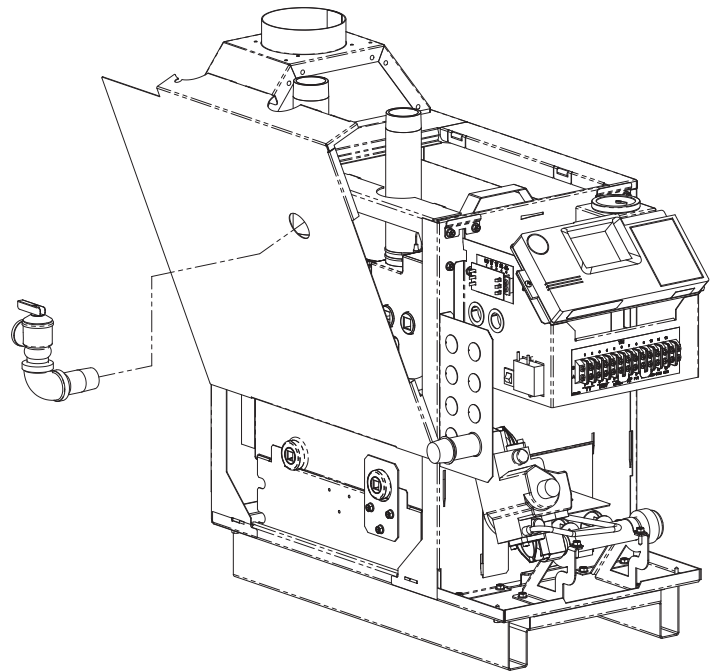

Figure 49. Side Panels and Draft Hood Removal

10.A.4 Draft Hood Removal

First remove the vent pipe. Keep all parts organized for reassembly.

Pull both bottom flanges outward approximately an inch. This frees the latching flanges which then allow the bottom to be pulled away from the boiler. With the hood at a slight angle, slide backward and upward freeing the top flange from the jacket.

Reverse the process to reinstall.

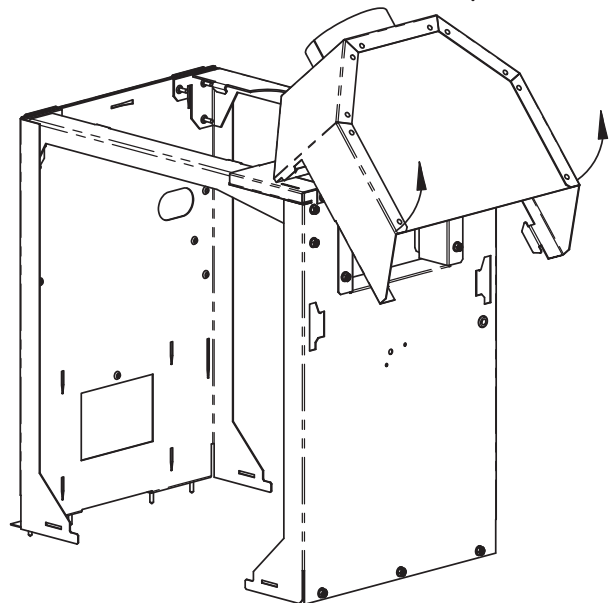

10.B Maintenance

⚠ WARNING

The Warranty does not cover damage caused by lack of required maintenance, lack of water flow, or improper operating practices.

⚠ AVERTISSEMENT

La garantie ne couvre pas les dommages causés par l'absence d'entretien, absence de débit d'eau, ou pratiques de fonctionnement irrégulières

1. Lubricate any motor bearings that are not sealed bearings per the instructions.
2. If a strainer is employed in a pressure reducing valve or the piping, clean it annually or as needed.
3. At start-up, and periodically thereafter, the burner and pilot flames should be observed. If the flame has the appearance of "sooting" tips, check for debris near the orifices. Clean any debris from orifice area and remove burners to ensure they are debris free inside and out. If this doesn't clear the issue the heat exchanger likely needs cleaning.
4. Ensure vent damper motors open and close by watching the connecting rod between the stack and the motor housing. The boiler should never start if the damper is not in the open position. If it does, it is critical to safe operation that this gets repaired.
5. Inspect the venting system for obstruction, leakage or corrosion at least once a year. Any venting system issues must be repaired before restarting the boiler.
6. Keep the boiler area clear and free from combustible materials, gasoline, and other flammable vapors and liquids.
7. Be sure that all combustion air and ventilation openings are unobstructed.
8. If the boiler is not going to be used for long periods of time in locations where freezing occurs, it should be completely drained of all water. To accomplish this, there is a drain valve on the right side of the boiler which can be opened. This will drain the right side of the boiler. There are two plugs located on the left side of the heater which can be accessed by removing the side panel which must be removed to drain that side. **BOTH SIDES MUST BE DRAINED.** See Section 9.E on page 40
9. The gas and electric controls on the boiler are engineered for long life and dependable operation, but the safety of the equipment depends on their proper functioning. It is strongly recommended that these basic items listed be inspected by a qualified service technician every year.
 - a. Water temperature controls.
 - b. Pilot safety system.
 - c. Automatic gas valves.
 - d. Low Water Cut Off (ensuring the sensor well is cleaned of exterior residue periodically based on system conditions)
 - e. Mechanical flue damper operation.
 - f. Pressure Relief Valve. The pressure relief valve lever must be tripped at least once a year to ensure that the waterways are clear. When manually operating lever, water will discharge through drain line and precautions must be taken to avoid contact with the hot water and to avoid water damage.
10. Inspect the heat exchanger for fouling. Fouling on the external surfaces of the heat exchanger is caused by incomplete combustion, and is a sign of venting and/or combustion air problems or too cold of a return water temperature. The heat exchanger can be inspected by using a flashlight and placing a mirror under the burners. An alternate method is to remove the top panel to inspect the exchanger from above. This boiler has easy access through the top cover and the flue collector for inspection of the heat exchanger. It is critical to ensure that the flue collector sits in the proper position so that no flue products will escape into the living area of the building.

If cleaning is required:

 - a. Shut off all power to the boiler.
 - b. Remove the top, flue collector, and heat exchanger baffles.
 - c. Remove the burners.
 - d. Use a hand-operated spray bottle filled with water, and a wire brush to clean soot and loose scale from the underside of the heat exchanger. **DO NOT USE COMPRESSED AIR, HIGH PRESSURE WATER, OR A GARDEN HOSE.**
 - e. Clean any fallen debris from the bottom of the unit.
 - f. Check to make sure the burner ports and pilot assembly are free of debris before returning the burners to their original positions.
 - g. Reassemble the boiler in reverse order, making sure to replace the heat exchanger baffles and flue collector into the proper location.

SECTION 11 Operating Details and Troubleshooting

11.A Operating Details

When power is turned on, the digital display will indicate the boiler outlet temperature. If a demand for heat is received from a room thermostat or a tank aquastat (if provided) the third decimal LED, located at the lower right of the last temperature digit, will illuminate to indicate that a call for heat has been received and the startup has been initiated. See Section 9.B for details. If the LED is not illuminated, that indicates that the System Startup has not been initiated because all system parameters are not in their proper operating range. See Section 11.C and 11.D for details and corrective procedures.

11.B Electrical Troubleshooting

1. Remove the front cover of the boiler.
2. Verify that 120 VAC is reaching the boiler by testing at terminals 2 and 5 on TB2.
3. Verify 24 volt transformer output by placing the meter leads on terminals 1 and 7 on TB1. If 24VAC isn't present, check the circuit breaker located next to the transformer. Reset the circuit breaker if it is tripped. If there still isn't any power at terminals 1 and 7 on TB1, then remove the control panel to gain access to the internal control wiring. Check transformer across the male push on terminals of the transformer.
4. To perform 24 VAC voltage checks attach one meter lead to terminal 7 of TB1. Use the other lead to check for power on any switch on the boiler.
5. To perform voltage checks on 120VAC attach one meter lead to either terminal 2 or 3 of TB1. Use the other lead to check for power at any high voltage terminal or device.
6. Use Section 9.B on page 36 for greater detail on how to follow the sequence of operation. Understanding the control panel's messages will help to localize the fault.
7. Use Section 7.F Wiring diagrams to follow where the power should be based on the information coming from the control panel's lights.

⚠ CAUTION

Label all wires prior to disconnection when servicing controls. Wiring errors can cause improper and dangerous operation. Verify proper operation after servicing.

⚠ ATTENTION

de mise en garde tous les fils avant le débranchement lors de l'entretien. Les erreurs de câblage peut causer le mauvais et dangereux. Vérifier le fonctionnement correct après l'entretien

⚠ WARNING

Follow local regulations with respect to installation of carbon monoxide (CO) detectors and manufacturer's maintenance schedule of the boiler.

⚠ AVERTISSEMENT

Conformez-vous aux réglementations locales pour ce qui est de l'installation de détecteur de monoxyde de carbone (CO) et du programme de maintenance du fabricant de la chaudière.

⚠ CAUTION

Electrical rework and troubleshooting should only be done by a qualified HVAC technician.

⚠ ATTENTION

Les retouches électriques et le dépannage ne doivent être effectués que par un technicien HVAC qualifié.

Temp (F)	Ohms
77	30,000
100	17,300
120	11,200
140	7,400
160	5,000
180	3,500
200	2,400
210	2,100

Table 10. Thermistor Readings

11.C Troubleshooting Table

#	Symptom	Cause	Remedy
1	Boiler Pump not operating	No power. Pump defective. Incorrectly wired.	Check circuit breakers and power source. Replace. Recheck wiring diagrams (System pump will not work if below 160°F or if DHW call)
2	Pilot outage	Inlet gas pressure too low.	Consult gas utility company. Inlet gas pressure to boiler should be 5.5" (1.4 kPa) to 10.5" (2.6 kPa) water column on natural gas. 10.0" (2.5k Pa) to 13.0" (3.2 kPa) on propane gas.
		Inlet gas pressure too high causing an unstable blowing pilot.	Pressure should be regulated within limits shown above.
		Damaged pilot.	Replace.
		Dirty pilot.	Blow dust or lint out of pilot.
		Plugged or undersized pilot.	Replace pilot orifice.
		No power from ignition control.	See Section 11.D on page 45 Refer to Ignition Section in the flow charts
3	Flame roll-out on start-up	Blocked outlet.	Check flue damper operation.
		Pilot out of position (delayed ignition).	Correct pilot position.
		Blocked heat exchanger or flue or dirty burners or orifices.	Clean and correct as necessary. Check orifice alignment.
		Refractory tile out of place.	Correct or replace tile as necessary.
4	Flame has lazy yellow tip	Low primary air.	Correct manifold pressure according to rating plate. Correct orifice size if necessary (see parts list). Clean burner ports if dirty. Check heat exchanger.
5	Not enough heat	Inadequate gas supply.	Gas meter too small. Gas line from meter to boiler too small.
		Low manifold gas pressure.	Gas pressure on boiler manifold. Must be adjusted to 4.0" (1.0 kPa) W.C. natural gas. 9.0" (2.2 kPa) W.C. propane. If the supply pressure is correct the gas valve regulator may be bad and need replacing.
		Boiler size inadequate	Replace with a boiler of a higher input.
		Burned Copper. Boiler was dry fired and copper has been damaged causing a reduced efficiency.	Replace heat exchanger.
6	Pump noisy	Air in volute.	Bleed air from volute. Check pump alignment.
		Worn bearings.	Replace worn parts.
7	Boiler pounding or knocking	Water flow too low through boiler.	Check temperature rise between inlet and outlet boiler piping. 15°F (8°C) to 25°F (14°C) temperature rise is recommended. If temperature rise is over 25°F (14°C), increase pipe size or pump capacity or locate obstruction. Check for stuck closed zone valves. Check for zone pumps not operating. Check for closed valve in system.
8	Boiler condensing	Low water temperature.	Flue product moisture will condense at the start-up until the boiler water temperature reaches the normal operating conditions. Check for proper wiring for anti-condensing protection. Install LLH or other piping arrangement to prevent low return water temperatures from reaching the boiler.
9	Pump cavities or low water pressure at boiler gauge or bubbles in system at high temperature	Defective fill valves or pressure regulator.	Replace and ensure a minimum of 12PSI.
		Expansion tank piped incorrectly.	Re-pipe expansion tank to suction side of pump.
10	Pressure relief valve opens	Waterlogged expansion tank.	Check charge in expansion tank. Replace or refill with proper charge of air.
11	Pilot is lit and ignition light is on, but main burners will not come on.	Main gas valve (MV) terminal is getting 24V power, gas valve is bad.	Check wiring and control, replace control if flame light is lit and no power is going to the MV terminal. Replace gas valve if power is present at MV terminal and valve isn't opening.
12	Boiler short cycles	Heat anticipator in room thermostat set too low.	Increase setting (1.0 is usually satisfactory)
		Low water flow through boiler.	Increase size of pump or increase piping size.
		Hi-limit may be set too low.	Increase differential. Adjust Economy mode or Reset curve. High limit should be set between 180-220F. See 8.B on page 32

11.D Troubleshooting Flow Charts

11.D.1 Troubleshooting Flow Chart 1 (burners off)

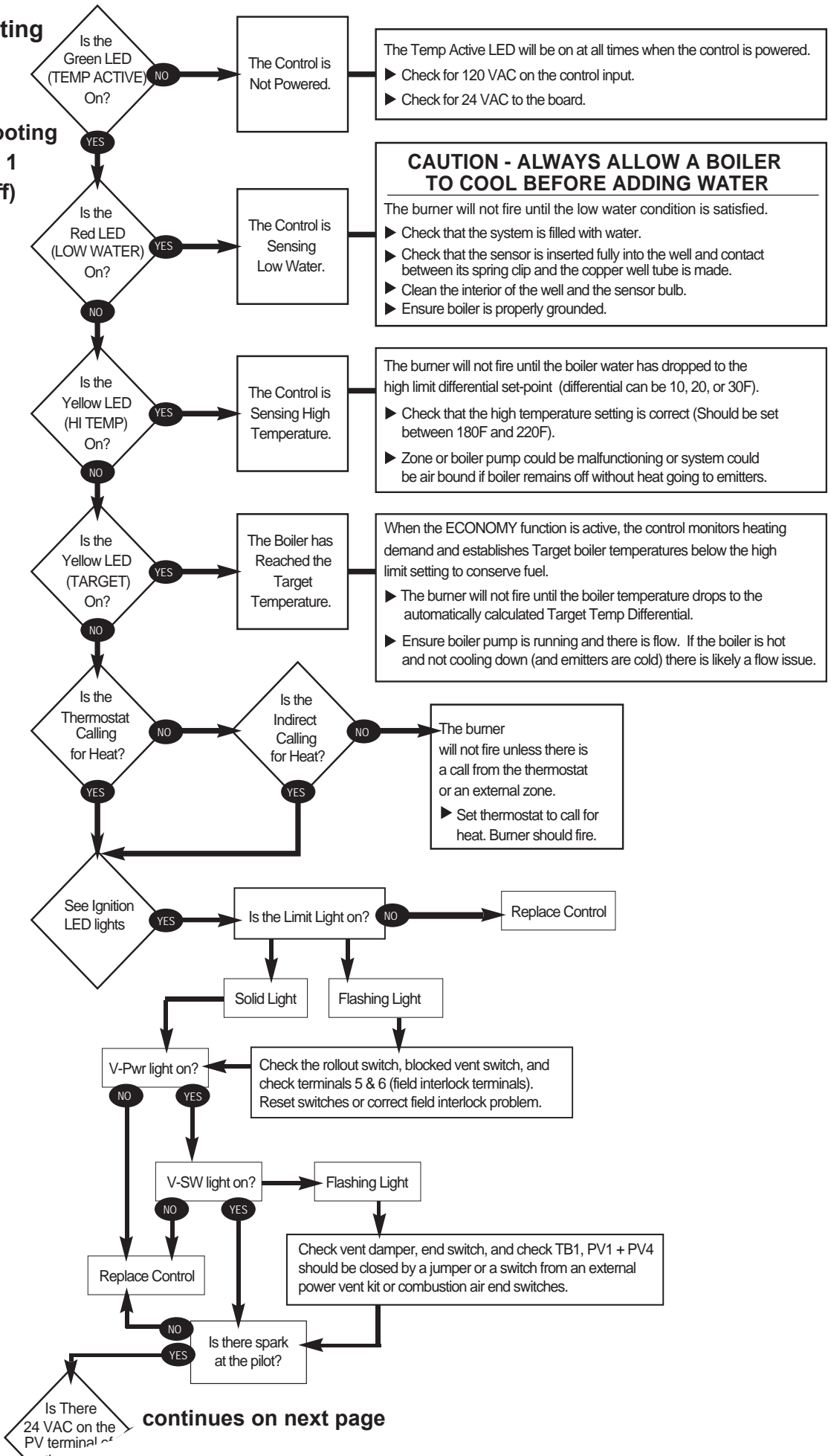

continues on next page

Troubleshooting Flow Chart 1 (burners off) (continued)

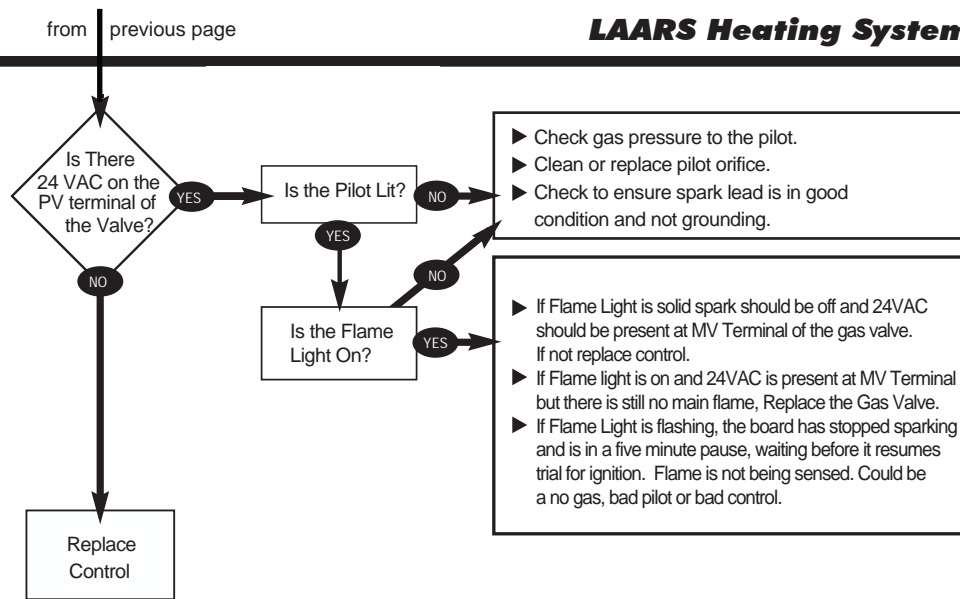

11.D.2 Troubleshooting Flow Chart 2 (burners on)

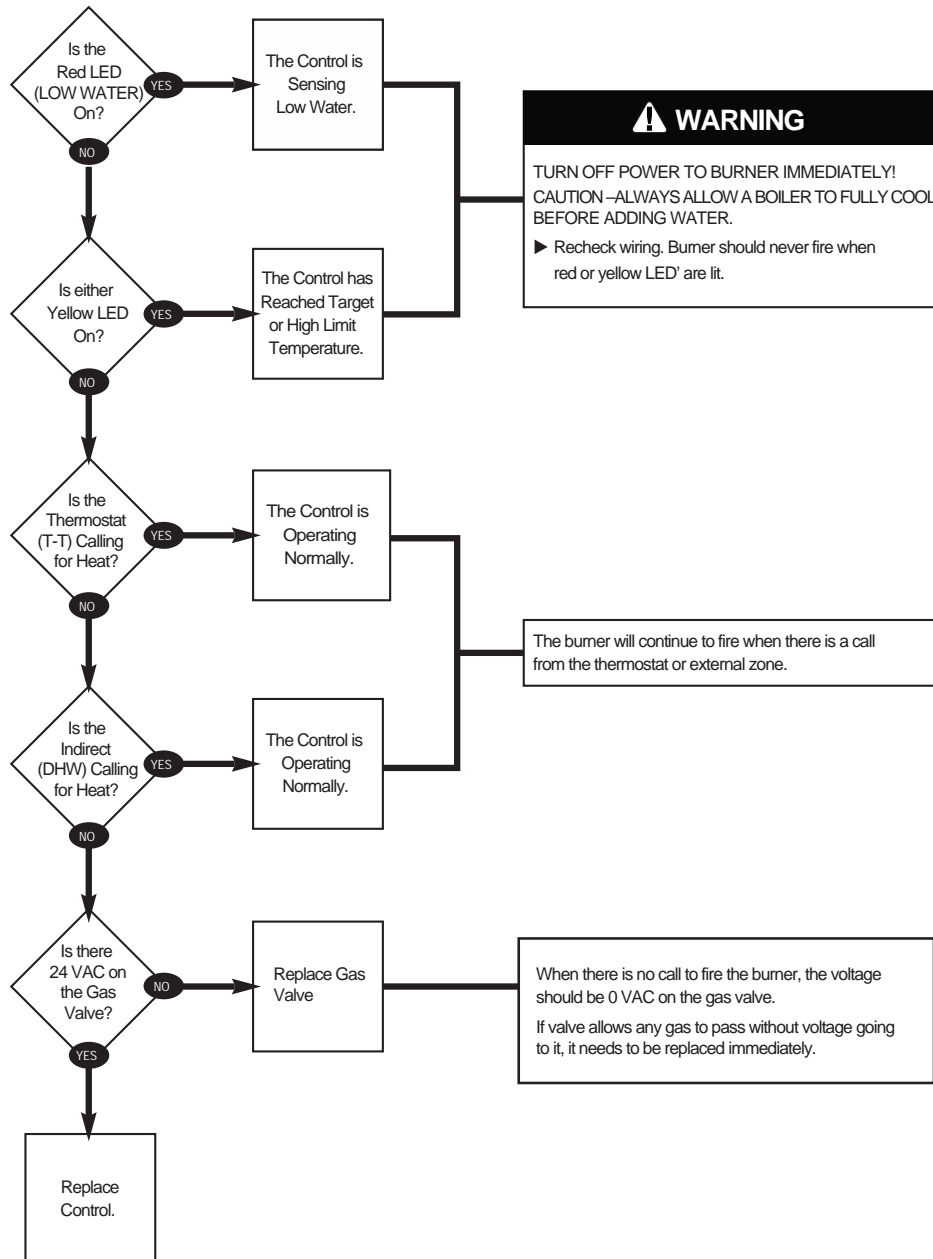

11.E Glossary of Terms

Air Vent

A device used to purge air from the circuit. It should be located at the highest point in the circuit.

Auto-Reduce

Reduces 5 degrees with every new call
Reduces 5 degrees every 30 minutes of no demand.

Branch

The section(s) of supply and return piping, including the heat distribution units connected directly to the trunk.
Also referred to as a "zone".

Circuit

Entire water circulation piping, beginning and ending at the boiler (Series Loop System).

Expansion Tank (Compression Tank)

Installed in the circuit to accommodate excess water produced by heat expansion.

Diaphragm Expansion Tank

Used instead of Expansion Tank (Compression Tank).
Internal bladder separates air and water.

Heat Distribution Units

Transfers heat from the water supplied by the boiler to the area to be heated through the use of baseboard, convector, radiator, finned tube. Also known as "radiation".

Isolation Valve

Used to isolate the boiler from the circuit. It minimizes the amount of water drained from the system.

Low Loss Header

Used to allow boiler flow to be independent of system flow so that Primary/Secondary system piping is unnecessary and system piping is simplified.

Primary-Secondary Piping

Two or more interconnecting circulating loops, each with its own pump. Primary =Boiler Circuit; Secondary=System Circuit.

Reverse-Return Piping

Balanced, equal flow (first in, last out) piping. Utilized with multiple boilers and/or radiation. Applied with single or multiple system pumps.

System Purge Valve

A device used to purge air from the circuit. Should be located as close as possible to the cold-water feed, but not immediately after the cold-water feed.

Temperature Controllers

The primary temperature controller maintains all normal heating operations.

Thermal Targeting

Monitors thermostat activity to adjust the boiler temperature to the minimum output required to meet heating load.

Thermal Boost

Boosts in 10 degree increments at timed intervals Up to Hi- Limit setting. Uses target differential of 20 degrees.

Trunk

The section of piping which connects the boiler return and supply with the branch(es). Also known as a "main" or "header". Should be same size as boiler inlet/outlet connections.

Zone Pump

Circulator installed in branch piping that diverts hot water coming from the boiler into various areas (zones) of a building.

Zone Valve

Diverts hot water from the boiler into various areas (zones) of a building.

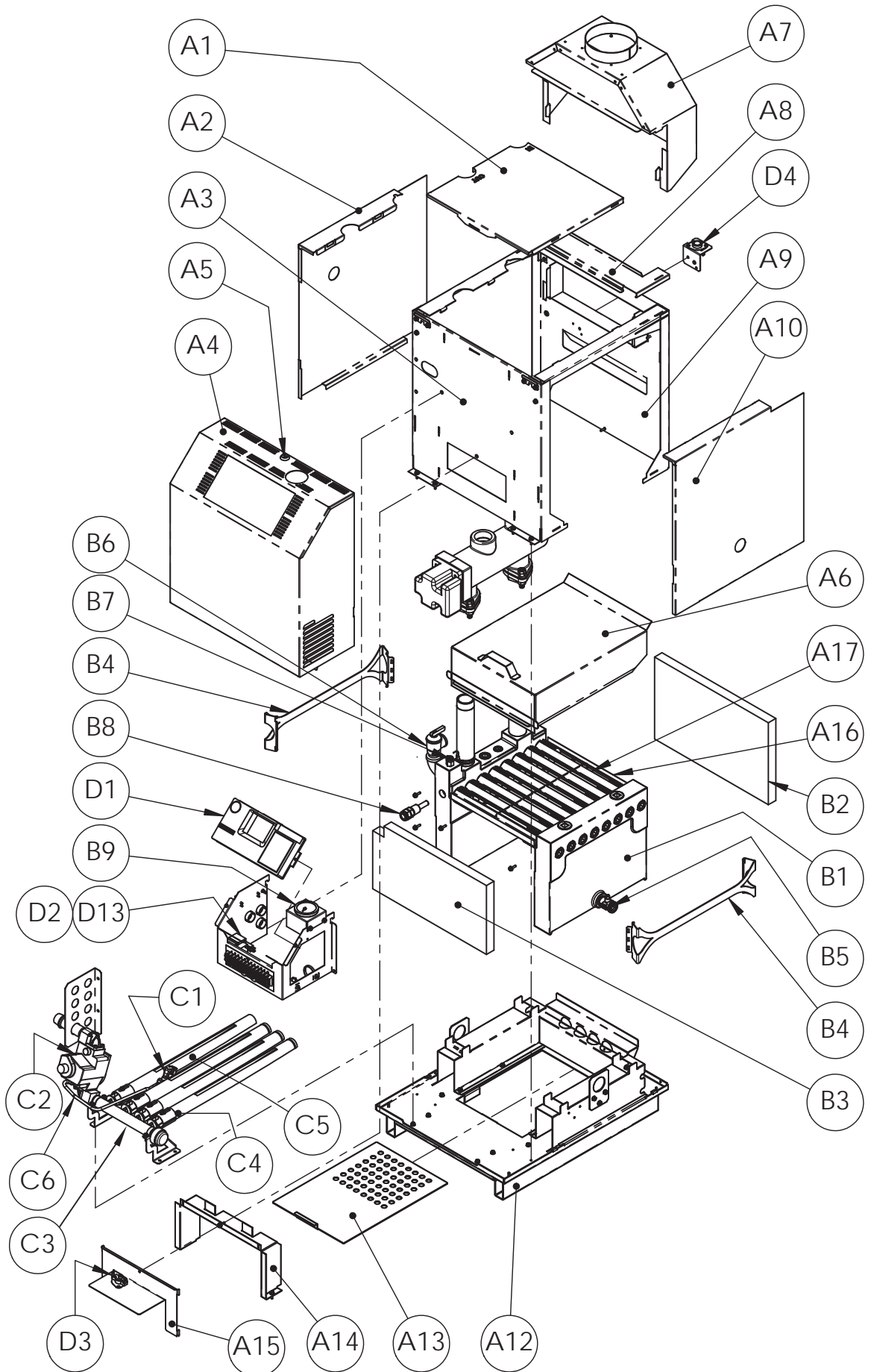

Parts List (continued)

	50	75	100	125	150	200
Main Gas Orifice (not shown)	Note: For complete conversion kits (LP or Nat all altitudes available) see accessory section.					
Natural Gas 0 -2000'	L0032200	L0032200	L0032200	L0032200	L0032200	L0032200
2001'-5000'	L0050700	L0050700	L0050700	L0050700	L0050700	L0050700
5001'-8000'	L0032600	L0032600	L0032600	L0032600	L0032600	L0032600
8001'-10000'	L0050300	L0050300	L0050300	L0050300	L0050300	L0050300
Propane 0 -2000'	L0039000	L0039000	L0039000	L0039000	L0039000	L0039000
2001'-5000'	L0032900	L0032900	L0032900	L0032900	L0032900	L0032900
5001'-8000'	L0032800	L0032800	L0032800	L0032800	L0032800	L0032800
8001'-10000'	L0032700	L0032700	L0032700	L0032700	L0032700	L0032700
C5 Burner W/Pilot Bracket	L0056500	L0056500	L0056500	L0056500	L0056500	L0056500
C6 Tube, Pilot	5X5002	5X5002	5X5002	5X5002	5X5002	5X5002
D Electrical System						
D1 Controller w/ limit sensor 24"	R2087800	R2087800	R2087800	R2087800	R2087800	R2087800
Limit Sensor 24"	E2407200	E2407200	E2407200	E2407200	E2407200	E2407200
D2 Transformer 115/24V (40VA)	R0021300	R0021300	R0021300	R0021300	R0021300	R0021300
D3 Roll-Out Switch, Man. Reset,250F SPST	E2103200	E2103200	E2103200	E2103200	E2103200	E2103200
D4 Blocked Vent Safety Switch	R2061100	R2061100	R2061100	R2061100	R2061100	R2061100
D5 Circuit Breaker, 2 AMP, Panel Mount	E2335100	E2335100	E2335100	E2335100	E2335100	E2335100
D6 Terminal Block Finger Guard	E2402100	E2402100	E2402100	E2402100	E2402100	E2402100
Wiring Harnesses (not shown)						
Low Voltage Harness (TB1 & damper)	E2403400	E2403400	E2403400	E2403400	E2403400	E2403400
X1 Connector Harness (Safety Chain)	E2402700	E2402700	E2402700	E2402700	E2402700	E2402700
LLH Pump Harness	-	-	20071500	E2402800	E2402800	E2402800
Pump Kit Harness	20071500	20071500	-	-	-	-
High Voltage Harness	E2402600	E2402600	E2402600	E2402600	E2402600	E2402600
Hi-Tension Ignition Lead	E2407000	E2407000	E2407000	E2407000	E2407000	E2407000
Vent Damper Assembly (not shown)	RE2071501	RE2071502	RE2071502	RE2071503	RE2071503	RE2071504

12.B Accessories List

	50	75	100	125	150	200
DHW Relay Kit	CA019400	CA019400	CA019400	CA019400	CA019400	CA019400
Relay, 24VAC, DTD	E2327800	E2327800	E2327800	E2327800	E2327800	E2327800
DHW Harness	E2404200	E2404200	E2404200	E2404200	E2404200	E2404200
Terminal Block Finger Guard	E2402100	E2402100	E2402100	E2402100	E2402100	E2402100
Outdoor Sensor	CA005400	CA005400	CA005400	CA005400	CA005400	CA005400
Power Vent Kits	CA019501	CA019501	CA019501	CA019502	CA019502	CA019502
Low Loss Header Kit for 50/75/100	CA019600	CA019600	CA019600	-	-	-
Conversion Kits						
LP 0- 2,000'	CA019901	CA019905	CA019909	CA019913	CA019917	CA019921
LP 2,001-5,000'	CA019902	CA019906	CA019910	CA019914	CA019918	CA019922
LP 5,001-8,000'	CA019903	CA019907	CA019911	CA019915	CA019919	CA019923
LP 8,001-10,000'	CA019904	CA019908	CA019912	CA019916	CA019920	CA019924
Nat 0- 2,000'	CA020001	CA020005	CA020009	CA020013	CA020017	CA020021
Nat 2,001-5,000'	CA020002	CA020006	CA020010	CA020014	CA020018	CA020022
Nat 5,001-8,000'	CA020003	CA020007	CA020011	CA020015	CA020019	CA020023
Nat 8,001-10,000'	CA020004	CA020008	CA020012	CA020016	CA020020	CA020024

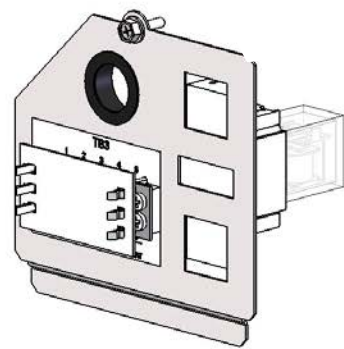
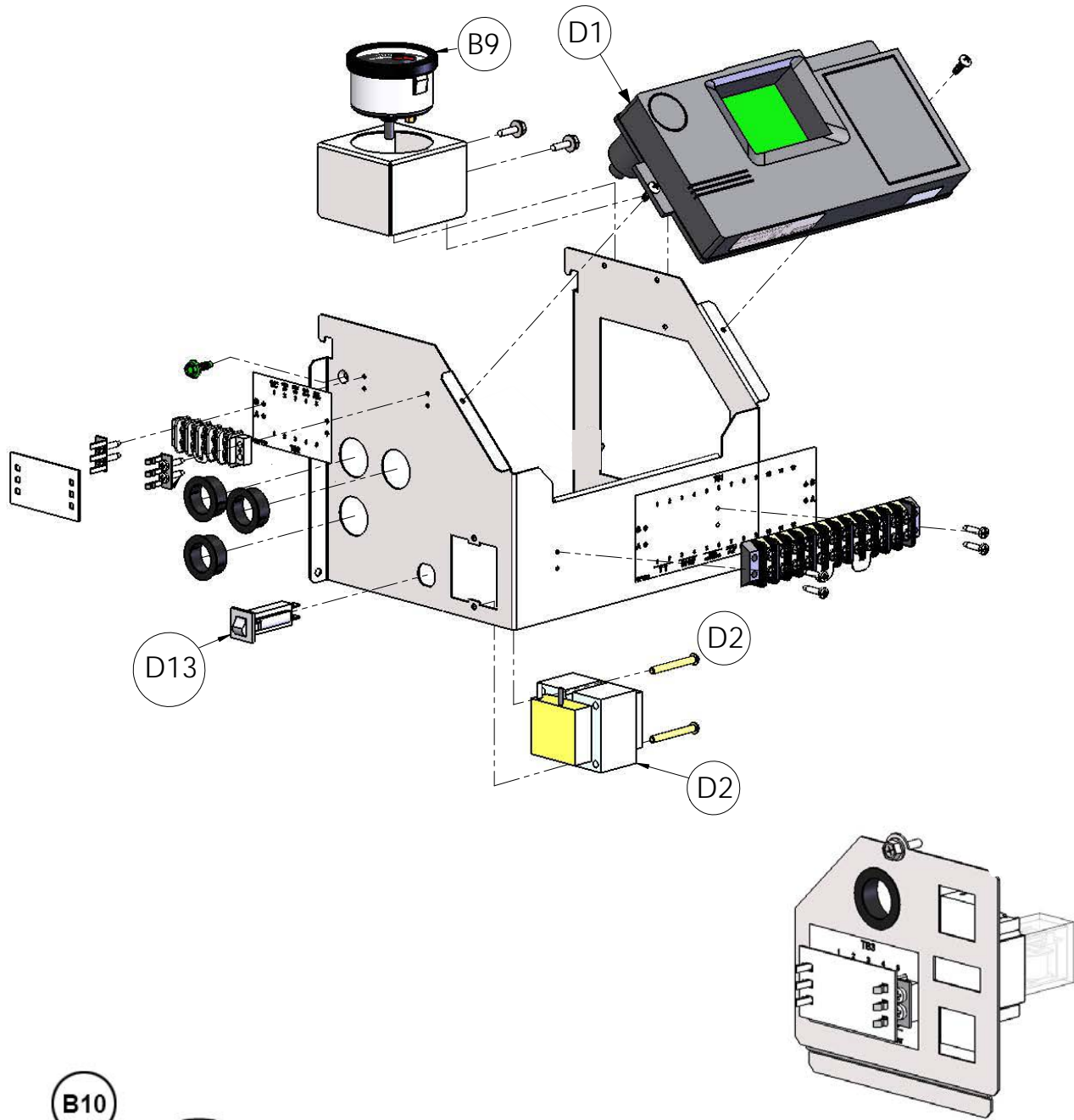

DHW Relay Kit

