



# UPFLOW/DOWNFLOW COILS

## INSTALLATION INSTRUCTIONS

### 1. Important Safety Instructions

The following symbols and labels are used throughout this manual to indicate immediate or potential safety hazards. It is the owner's and installer's responsibility to read and comply with all safety information and instructions accompanying these symbols. Failure to heed safety information increases the risk of personal injury, property damage, and/or product damage.

 <b>WARNING</b>	
<b>HIGH VOLTAGE</b> DISCONNECT ALL POWER BEFORE SERVICING OR INSTALLING THIS UNIT. MULTIPLE POWER SOURCES MAY BE PRESENT. FAILURE TO DO SO MAY CAUSE PROPERTY DAMAGE, PERSONAL INJURY OR DEATH.	

 <b>WARNING</b>	
<b>ONLY PERSONNEL THAT HAVE BEEN TRAINED TO INSTALL, ADJUST, SERVICE OR REPAIR (HEREINAFTER, "SERVICE") THE EQUIPMENT SPECIFIED IN THIS MANUAL SHOULD SERVICE THE EQUIPMENT. THE MANUFACTURER WILL NOT BE RESPONSIBLE FOR ANY INJURY OR PROPERTY DAMAGE ARISING FROM IMPROPER SERVICE OR SERVICE PROCEDURES. IF YOU SERVICE THIS UNIT, YOU ASSUME RESPONSIBILITY FOR ANY INJURY OR PROPERTY DAMAGE WHICH MAY RESULT. IN ADDITION, IN JURISDICTIONS THAT REQUIRE ONE OR MORE LICENSES TO SERVICE THE EQUIPMENT SPECIFIED IN THIS MANUAL, ONLY LICENSED PERSONNEL SHOULD SERVICE THE EQUIPMENT. IMPROPER INSTALLATION, ADJUSTMENT, SERVICING OR REPAIR OF THE EQUIPMENT SPECIFIED IN THIS MANUAL, OR ATTEMPTING TO INSTALL, ADJUST, SERVICE OR REPAIR THE EQUIPMENT SPECIFIED IN THIS MANUAL WITHOUT PROPER TRAINING MAY RESULT IN PRODUCT DAMAGE, PROPERTY DAMAGE, PERSONAL INJURY OR DEATH.</b>	

### 2. Shipping Inspection

Upon receiving the product, inspect it for damage from shipment. Shipping damage, and subsequent investigation is the responsibility of the carrier. Verify the model number, specifications, and accessories are correct prior to installation. The distributor or manufacturer will not accept claims from dealers for transportation damage or installation of incorrectly shipped units.

### 2.1 Handling

Use caution when transporting / carrying unit. Do not carry unit with hooks or sharp object. The preferred method of carrying the unit after arrival at the job site is to carry by two-wheel hand truck from the back or sides or by hand by carrying at the cabinet corners.

### 3. Codes & Regulations

This product is designed and manufactured to comply with national codes. Installation in accordance with such codes and/or prevailing local codes/regulations is the responsibility of the installer. The manufacturer assumes no responsibility for equipment installed in violation of any codes or regulations.

The United States Environmental Protection Agency (EPA) has issued various regulations regarding the introduction and disposal of refrigerants. Failure to follow these regulations may harm the environment and can lead to the imposition of substantial fines. Should you have any questions please contact the local office of the EPA.

### 4. Replacement Parts

Inspect the unit to verify all required components are present and intact. Report any missing components immediately to the manufacturer or to the distributor. Make sure to include the full product model number and serial number when reporting and/or obtaining service parts. Replacement parts for this product are available through your contractor or local distributor. For the location of your nearest distributor consult the white business pages, the yellow page section of the local telephone book or contact:

HOMEOWNER SUPPORT  
GOODMAN MANUFACTURING COMPANY, L.P.  
19001 KERMIER ROAD  
WALLER, TEXAS 77484  
877-254-4729

### 5. Pre-Installation Instructions

#### 5.1 Preparation

Keep this document with the unit. Carefully read all instructions for the installation prior to installing product. Make sure each step or procedure is understood and any special considerations are taken into account before starting installation. Assemble all tools, hardware and supplies needed to complete the installation. Some items may need to be purchased locally. Make sure everything needed to install the product is on hand before starting.



## 5.2 Clearances

Refrigerant lines must be routed depending on configuration of unit to maintain the required 24" minimum clearance for service. Consult all appropriate regulatory codes prior to determining final clearances. In installations that may lead to physical damage (i.e. a garage) it is advised to install a protective barrier to prevent such damage. Always install units such that a positive slope in condensate line (1/4" per foot) is allowed.

## 6. Application Information

Coils are designed for indoor installation only and must be installed downstream (discharge air) of the furnace. The CAPTA product line may be installed in upflow or downflow orientations.

## 7. Condensate Drain Piping

In all cooling applications where condensate overflow may cause damage, a secondary drain pan must be provided by the installer and placed under the entire unit with a separate drain line properly sloped and terminated in an area visible to the owner. This secondary drain pan can provide extra protection to the area under the unit should the primary drain plug up and overflow. For coils with "A" Cabinets (14" wide), use float switch if secondary drain line is not installed. Refer to product nomenclature from product specification literature to identify coil models with "A" cabinets. As expressed in our product warranty, we will not be liable for any damages, structural or otherwise due to the failure to follow this installation requirement.

Condensate drain connections are located in the drain pan at the bottom of the coil/enclosure assembly. Use the female (3/4" FPT) threaded fitting that protrudes outside of the enclosure for external connections. The connectors required are 3/4" NPT male, either PVC or metal pipe, and must be hand tightened to a torque of no more than 37 in-lbs. to prevent damage to the drain pan connection. An insertion depth between .36 to .49 inches (3-5 turns) should be expected at this torque. Insulate PVC drain lines/pipes with high heat resistive tape within 1" furnace flue/vent pipe. Foil-Mastic Sealant tape is the preferred wrapping material.

1. Ensure drain pan hole is NOT obstructed.
2. To prevent potential sweating and dripping on finished space, it may be necessary to insulate the condensate drain line located inside the building. Use Armaflex® or similar material.

A Secondary Condensate Drain Connection, now called for by many building codes, has been provided. Pitch the drain line 1/4" per foot to provide free drainage. Provide required support to drain line to prevent bowing. Install a condensate trap in the primary drain line to ensure proper drainage. If the secondary drain line is required, run the line separately from the primary drain and end it where condensate discharge can be easily seen.

 <b>CAUTION</b>
<b>IF SECONDARY DRAIN IS NOT INSTALLED, THE SECONDARY ACCESS MUST BE PLUGGED.</b>

## 8. Plastic Drain Pan Application

 <b>WARNING</b>
<b>DO NOT USE THE COIL PAN SHIPPED WITH THE UNIT ON OIL FURNACES OR ANY APPLICATION WHERE THE TEMPERATURE OF THE DRAIN PAN MAY EXCEED 300°F. A HIGH TEMPERATURE DRAIN PAN SUCH AS KITS HTP-A, -B, -C, AND -D FOR NORMAL CABINET WIDTHS OF 14, 17.5, 21 AND 24.5 INCHES, RESPECTIVELY, SHOULD BE USED FOR APPLICATIONS WHERE THE TEMPERATURE EXCEEDS 300°F AND BELOW 450°F. A FIELD FABRICATED METAL DRAIN PAN CAN ALSO BE USED FOR APPLICATIONS WHERE TEMPERATURE EXCEEDS 300°F. FAILURE TO FOLLOW THIS WARNING MAY RESULT IN PROPERTY DAMAGE AND/OR PERSONAL INJURY.</b>

If the uncased coil is to be installed on top of a gas furnace, allow enough space between the top to the furnace and the bottom of the plastic coil drain pan to have a free flow of air. A minimum of 2.0" distance from the top of the furnace and the bottom of the coil pan is required.

NOTE: The coil must be installed with the line set and drain openings to the front of the furnace.

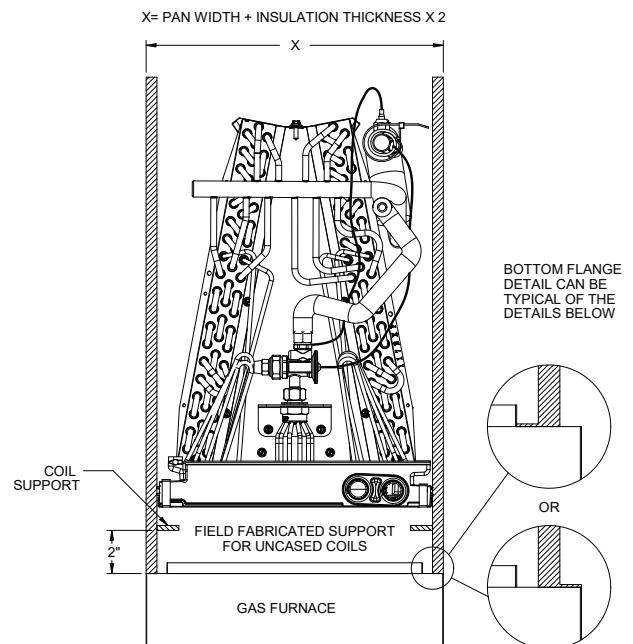

Figure 1

NOTE: Water coming from the secondary line means the coil primary drain is plugged and needs immediate attention. Install a trap in the drain line below the bottom of the drain pan (Figure 1). If using a copper drain line, solder a short piece of pipe, minimum 6" length, to the connector before installing a drain fitting.

DO NOT over torque the 3/4" copper connector to the plastic drain connection. Using a wet rag or heatsink material on the short piece to protect the plastic drain pan, complete the drain line installation. Use Figure 2 as a template for typical drain pipe routing. This figure shows how to avoid interference with vent piping.

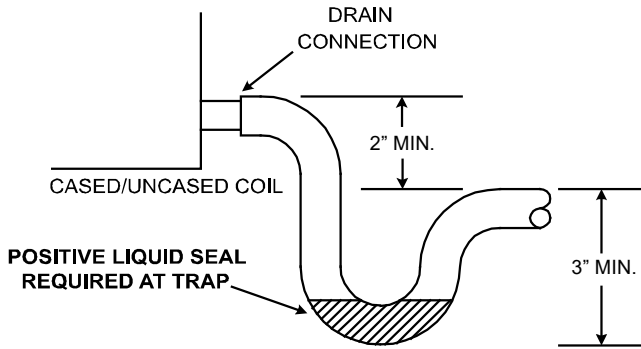

Figure 2

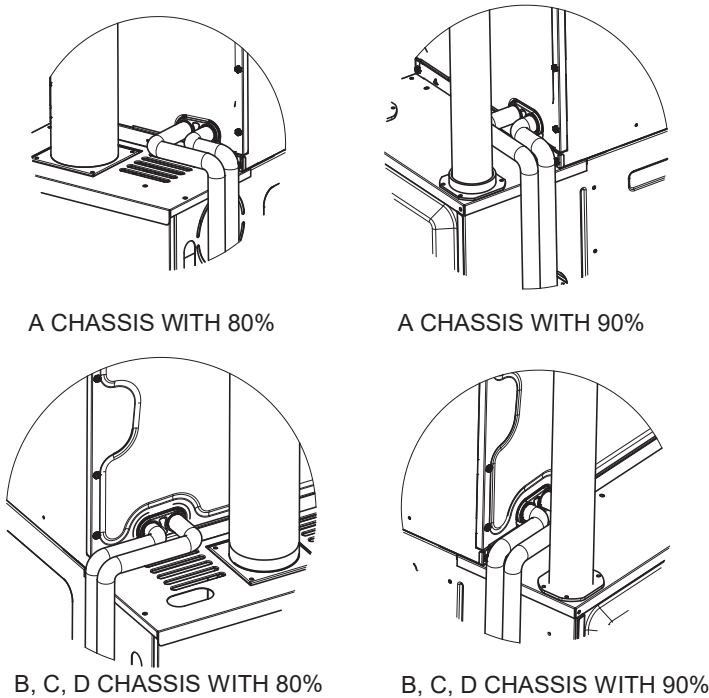

Figure 3

8.1 Condensate Drain Pan Break-away Feature

The drain pan (0161D00116) possesses a break-away feature on the lip located on the front-top and rear-top of the drain pan. This feature is to be used for uncased installations, as necessary. The force required to break the lip is 18lbf uniformly distributed over the feature. A force of 8lbf localized on the corner of the lip can also be applied. (Applies only for A-size Cabinet) See Figure 4

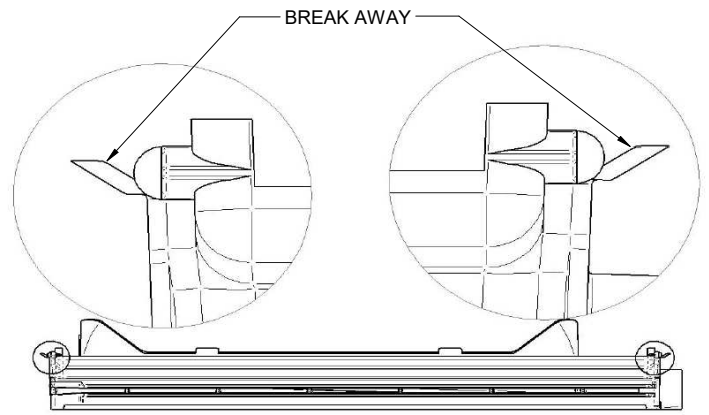

Figure 4

9. Refrigerant Lines

	<b>CAUTION</b>
<p>THE COIL IS SHIPPED UNDER PRESSURE WITH A R-410A GAS MIXTURE. USE APPROPRIATE SERVICE TOOLS AND FOLLOW THESE INSTRUCTIONS TO PREVENT INJURY.</p>	
	<b>WARNING</b>
<p>A QUENCHING CLOTH IS STRONGLY RECOMMENDED TO PREVENT SCORCHING OR MARRING OF THE EQUIPMENT FINISH WHEN BRAZING CLOSE TO THE PAINTED SURFACES. USE BRAZING ALLOY OF 5% MINIMUM SILVER CONTENT.</p>	

NOTE: Refrigerant tubing must be routed to allow adequate access for servicing and maintenance of the unit.

Do not handle coil assembly with manifold or flowrator tubes. Doing so may result in damage to the tubing joints. Always use clean gloves for handling coil assemblies.

9.1 Tubing Size/Length

For the correct tubing size, follow the specification for the condenser/heat pump. Give special consideration to minimizing the length of refrigerant tubing when installing coils. Refer to Remote Cooling/Heat Pump Technical Publication TP-107\* Long Line Set Application R-410A for guidelines for line lengths over 80'. Leave a minimum 3" straight in line set from braze joints before any bends.

9.2 Tubing Preparation

All cut ends are to be round, burr free, and cleaned. Any other condition increases the chance of a refrigerant leak. Use a pipe cutter to remove the closed end of the spun closed suction line.

9.3 Brazing

Braze joints should be made only with the connections provided external to the cabinet. Do not alter the cabinet nor braze inside the cabinet. To avoid overheating after brazing, quench all brazed joints with water or a wet rag.



## CAUTION

APPLYING TOO MUCH HEAT TO ANY TUBE CAN MELT THE TUBE. TORCH HEAT REQUIRED TO BRAZE TUBES OF VARIOUS SIZES MUST BE PROPORTIONAL TO THE SIZE OF THE TUBE. SERVICE PERSONNEL MUST USE THE APPROPRIATE HEAT LEVEL FOR THE SIZE OF THE TUBE BEING BRAZED.

### 9.4 Tubing Connections for TXV Version

TXV models come with factory installed adjustable TXV with the bulb permanently located on the suction tube.

1. Remove coil access panel and rubber grommets.
2. Remove access valve fitting cap and depress the valve stem in access fitting to release pressure. No pressure indicates possible leak.
3. Reinstall the the Coil Access Panel & rubber grommets.
4. Remove the spin closure on both the liquid and suction tubes using a tubing cutter. **DO NOT USE A CUTTING METHOD THAT WOULD RESULT IN THE GENERATION OF COPPER SHAVINGS OR COPPER DUST.**

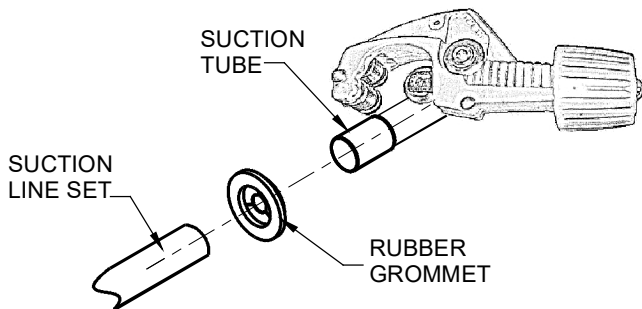

Figure 5.1

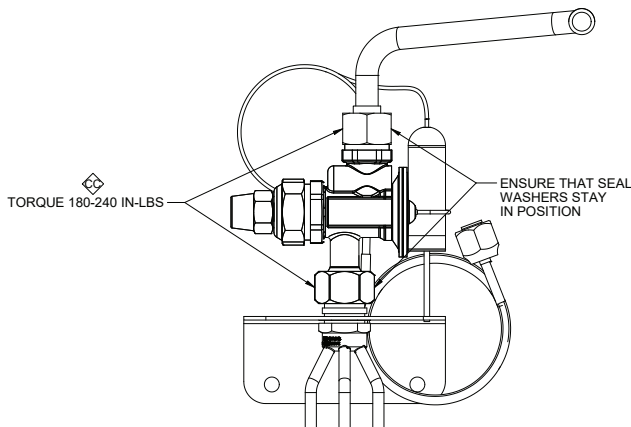

Figure 5.2



## CAUTION

EXCESSIVE TORQUE CAN CAUSE TXV RETAINING RING TO WEAKEN & CREATE LEAK AND WILL BECOME DIFFICULT TO RE-INSTALL TXV. USE THE PROPER TORQUE (180-240 IN. LBS) SETTINGS WHEN TIGHTENING THE TXV OR HAND TIGHTEN PLUS 1/2 TURN.

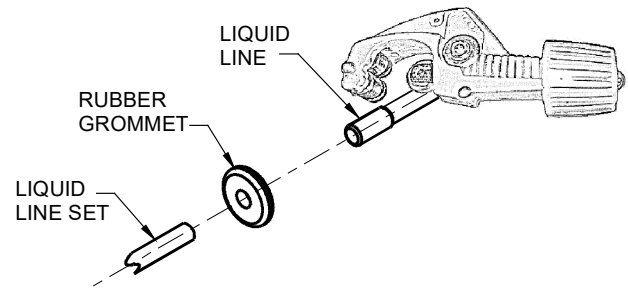

Figure 5.3

5. Insert liquid line set into liquid tube expansion and slide grommet about 18" away from braze joint.
6. Insert suction line set into suction tube expansion and slide insulation and grommet about 18" away from braze joint.
7. Braze suction and liquid line joints.

### 9.5 Thermal Expansion Valve System Adjustment

Run the system at Cooling for 10 minutes until refrigerant pressures stabilize. Use the following guidelines and methods to check unit operation and ensure that the refrigerant charge is within limits. Charge the unit on low stage.

Purge gauge lines. Connect service gauge manifold to base-valve service ports.

Temporarily install a thermometer on the liquid line at the liquid line service valve and 4-6" from the compressor on the suction line. Ensure the thermometer makes adequate contact and is insulated for best possible readings. Use liquid line temperature to determine subcooling and vapor temperature to determine superheat.

Check subcooling and superheat. Systems with TXV application should have a subcooling of 7 to 9°F and superheat of 7 to 9 °F.

- a. If subcooling and superheat are low, adjust TXV to 7 to 9 °F superheat, then check subcooling.  
NOTE: To adjust superheat, turn the valve stem clockwise to increase and counter clockwise to decrease.
- b. If subcooling is low and superheat is high, add charge to raise subcooling to 7 to 9°F then check superheat.
- c. If subcooling and superheat are high, adjust TXV valve to 7 to 9 °F superheat, then check subcooling.

SATURATED SUCTION PRESSURE TEMPERATURE CHART		
SUCTION PRESSURE PSIG	SATURATED SUCTION	
	R-22	R-410A
50	26	1
52	28	3
54	29	4
56	31	6
58	32	7
60	34	8
62	35	10
64	37	11
66	38	13
68	40	14
70	41	15
72	42	16
74	44	17
76	45	19
78	46	20
80	48	21
85	50	24
90	53	26
95	56	29
100	59	31
110	64	36
120	69	41
130	73	45
140	78	49
150	83	53
160	86	56
170	90	60

SATURATED LIQUID PRESSURE TEMPERATURE CHART		
LIQUID PRESSURE PSIG	SATURATED LIQUID TEMPERATURE °F	
	R-22	R-410A
200	101	70
210	105	73
220	108	76
225	110	78
235	113	80
245	116	83
255	119	85
265	121	88
275	124	90
285	127	92
295	130	95
305	133	97
325	137	101
355	144	108
375	148	112
405	155	118
415	157	119
425	n/a	121
435	n/a	123
445	n/a	125
475	n/a	130
500	n/a	134
525	n/a	138
550	n/a	142
575	n/a	145
600	n/a	149
625	n/a	152

d. If subcooling is high and superheat is low, adjust TXV valve to 7 to 9°F superheat and remove charge to lower the subcooling to 7 to 9°F.

NOTE: Do NOT adjust the charge based on suction pressure unless there is a gross undercharge.

Disconnect manifold set, installation is complete.

NOTE: Check the Schrader ports for leaks and tighten valve cores if necessary. Install caps finger-tight.

SUBCOOL FORMULA =  
SAT. LIQUID LINE TEMP. - LIQUID LINE TEMP.  
SUPERHEAT FORMULA =  
SUCTION LINE TEMP. - SAT. SUCTION TEMP.

## 10. Supply Duct Connection

1. Top flanges can be bent for ease in installation to the duct flanges. (See Figure 6)

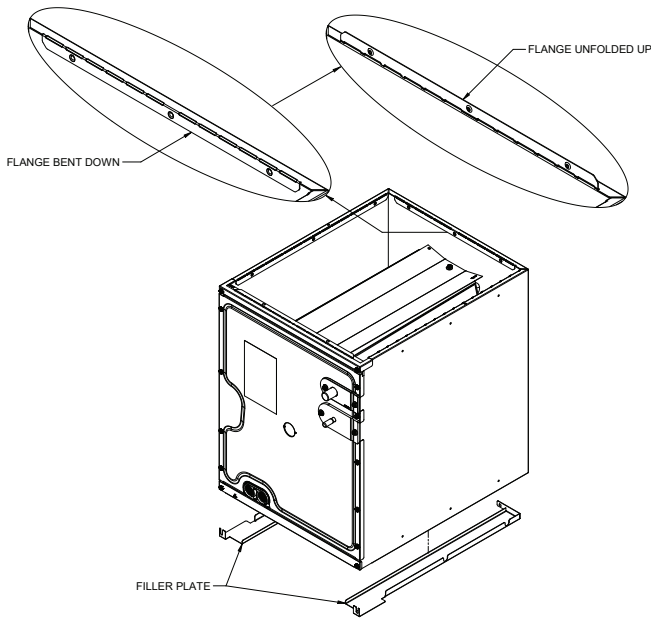

Figure 6

2. A duct flange kit can also be purchased from your distributor. (See Figure 7)

- 14 inch chassis - CLDUCTFLGA
- 17.5 inch chassis - CLDUCTFLGB
- 21 inch chassis - CLDUCTFLGC
- 24.5 inch chassis - CLDUCTFLGD

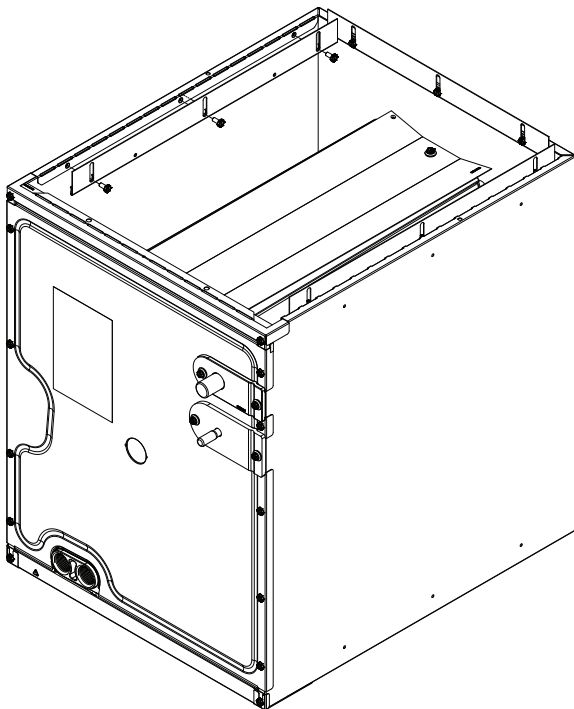

Figure 7

### 11. Filler Plates

Filler plates are supplied on all 17.5, 21, & 24.5 inch chassis to be used for adapting the unit to a furnace one size smaller. If the plenum and furnace openings are the same size, the filler plates must be removed. See Figure 6.

### 12. Return Ductwork

**DO NOT TERMINATE THE RETURN DUCTWORK IN AN AREA THAT CAN INTRODUCE TOXIC OR OBJECTIONABLE FUMES/ODORS INTO THE DUCTWORK.**

### 13. Sealing Along The Panel Gap

**IMPORTANT NOTE:** To prevent cabinet sweating and airflow leak, apply field provided insulation tape along all joining surfaces between the coil, gas furnace, duct work and panels. See Figure 8.

### 14. Removing Coil from Cabinet

In an event of removing taller coils from cabinet to service or replace; remove access panel, remove top tie rail to allow the coils to slide out of the cabinet.

After service or replacement slide the coil back in the cabinet and secure the top tie rail and re-install access panel.

See Figure 9.

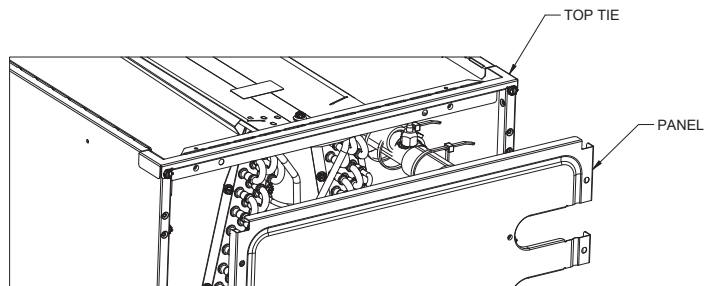

Figure 9

Clean Comfort brand UV coil purifiers also can be purchased from distributor. Maximum UV lamp diameter to be used per delta plate knockout design is 1.375" to reduce the possibility of air leak.

Refer to UV coil purifiers product specification and installation manual for additional details.

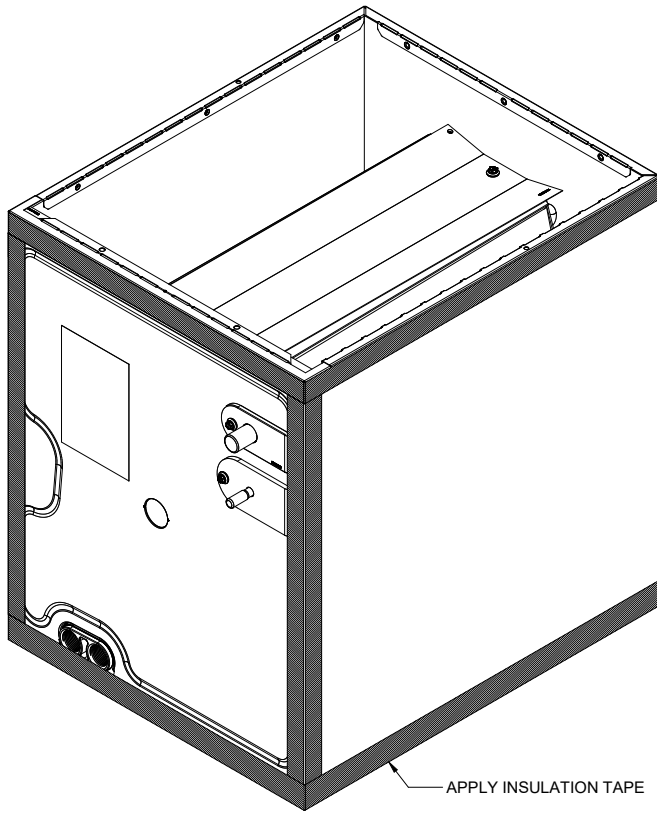

Figure 8

### 15. Aluminum Indoor Coil Cleaning (Qualified Servicer Only)



This unit is equipped with an aluminum tube evaporator coil. The safest way to clean the evaporator coil is to simply flush the coil with water. This cleaning practice remains as the recommended cleaning method for both copper tube and aluminum tube residential evaporator coils.

It has been determined that many coil cleaners and drain pan tablets contain corrosive chemicals that can be harmful to aluminum tube and fin evaporator coils. Even a one-time application of these corrosive chemicals can cause premature aluminum evaporator coil failure. Any cleaners that contain corrosive chemicals including, but not limited to, chlorine and hydroxides, should not be used.

An alternate cleaning method is to use one of the products listed in TP-109\* to clean the coils. The cleaners listed are the only agents deemed safe and approved for use to clean round tube aluminum coils. TP-109 is also available on the web site in Partner Link > Service Toolkit.

NOTE: Ensure coils are rinsed well after use of any chemical cleaners.

### 16. Start-Up Procedure

 <b>WARNING</b>
<p><b>HIGH VOLTAGE</b> DISCONNECT ALL POWER BEFORE SERVICING OR INSTALLING THIS UNIT. MULTIPLE POWER SOURCES MAY BE PRESENT. FAILURE TO DO SO MAY CAUSE PROPERTY DAMAGE, PERSONAL INJURY OR DEATH.</p> 

- Prior to start-up, ensure that all electrical wires are properly sized and all connections are properly tightened.
- All panels must be in place and secured. For Air Tight application, gasket must be positioned at prescribed locations to achieve 1.4% leakage.
- Tubing must be leak free.
- Condensate line must be trapped and pitched to allow for drainage.
- Low voltage wiring is properly connected.
- Auxilliary drain is installed when necessary and pitched to allow for drainage.
- Unit is protected from vehicular or other physical damage.
- Return air is not obtained from, nor are there any return air duct joints that are unsealed in, areas where there may be objectionable odors, flammable vapors or products of combustion such as carbon monoxide (CO), which may cause serious personal injury or death..

**Air Handler / Coil**

Model Number \_\_\_\_\_  
 Serial Number \_\_\_\_\_

**ELECTRICAL**

Line Voltage (Measure L1 and L2 Voltage) L1 - L2 \_\_\_\_\_  
 Secondary Voltage (Measure Transformer Output Voltage) R - C \_\_\_\_\_  
 Blower Amps \_\_\_\_\_  
 Heat Strip 1 - Amps \_\_\_\_\_  
 Heat Strip 2 - Amps \_\_\_\_\_

**BLOWER EXTERNAL STATIC PRESSURE**

Return Air Static Pressure \_\_\_\_\_ IN. W.C.  
 Supply Air Static Pressure \_\_\_\_\_ IN. W.C.  
 Total External Static Pressure (Ignoring +/- from the reading above, add total here) \_\_\_\_\_ IN. W.C.

**TEMPERATURES**

Return Air Temperature (Dry bulb / Wet bulb) \_\_\_\_\_ DB °F \_\_\_\_\_ WB °F  
 Cooling Supply Air Temperature (Dry bulb / Wet bulb) \_\_\_\_\_ DB °F \_\_\_\_\_ WB °F  
 Heating Supply Air Temperature \_\_\_\_\_ DB °F  
 Temperature Rise \_\_\_\_\_ DB °F  
 Delta T (Difference between Supply and Return Temperatures) \_\_\_\_\_ DB °F

**Air Handler / Coil - (Inverter Matched)**

**INVERTER AH / COIL ONLY**

Check EEV and EEV wiring is secure (no adjustment required) \_\_\_\_\_

**Additional Checks**

Check wire routings for any rubbing \_\_\_\_\_  
 Check product for proper draining \_\_\_\_\_  
 Check screw tightness on blower wheel \_\_\_\_\_  
 Check factory wiring and wire connections \_\_\_\_\_  
 Check product for proper clearances as noted by installation instructions \_\_\_\_\_

**°F to °C formula: (°F - 32) divided by 1.8 = °C      °C to °F formula: (°C multiplied by 1.8) + 32 = °F**



THIS PAGE LEFT INTENTIONALLY BLANK

THIS PAGE LEFT INTENTIONALLY BLANK

THIS PAGE LEFT INTENTIONALLY BLANK

#### CUSTOMER FEEDBACK

We are very interested in all product comments.

Please fill out the feedback form on one of the following links:

Daikin Products: (<https://daikincomfort.com/contact-us>)

Goodman® Brand Products: (<http://www.goodmanmfg.com/about/contact-us>).

Amana® Brand Products: (<http://www.amana-hac.com/about-us/contact-us>).

You can also scan the QR code on the right for the product brand you purchased to be directed to the feedback page.



DAIKIN



GOODMAN® BRAND



AMANA® BRAND

#### PRODUCT REGISTRATION

Thank you for your recent purchase. Though not required to get the protection of the standard warranty, registering your product is a relatively short process, and entitles you to additional warranty protection, except that failure by California and Quebec residents to register their product does not diminish their warranty rights.

For Product Registration, please register as follows:

Daikin Products: (<https://daikincomfort.com/owner-support/product-registration>).

Goodman® Brand products: (<https://www.goodmanmfg.com/product-registration>).

Amana® Brand products: (<http://www.amana-hac.com/product-registration>).

You can also scan the QR code on the right for the product brand you purchased to be directed to the Product Registration page.



DAIKIN



GOODMAN® BRAND



AMANA® BRAND

NOTE: SPECIFICATIONS AND PERFORMANCE DATA LISTED HEREIN ARE SUBJECT TO CHANGE WITHOUT NOTICE

19001 Kermier Rd, Waller, TX 77484

© 2021 Goodman Manufacturing Company, L.P.

[www.goodmanmfg.com](http://www.goodmanmfg.com)

**Amana** is a registered trademark of Maytag Corporation or its related companies and is used under license. All rights reserved.