

Cash Acme™ EB45 Pressure Regulating Valve

The Cash Acme™ EB45 Pressure Regulating Valve features the simplicity and performance of a cartridge-based design with the added benefit of direct access to the pressure adjusting screw. The EB45 comes factory set at 45 psi but may be adjusted between 10-70 psi.

Approved Applications

Commercial and domestic water applications.

Specification Data

Performance	
Maximum pressure	400 psi (1/2", 3/4" and 1") 300 psi (1-1/4", 1-1/2" and 2")
Temperature Range	33°F - 180°F (0.6°C - 82.2°C)
Service	Water
Outlet pressure range	10-70 psi

Materials		
1	Body	Lead-Free ¹ Brass
2	Spring Chamber	1/2" and 3/4" Models Reinforced Engineered Polymer or Iron
		1" through 2" Models Iron
3	Adjusting Spring	Steel (Zinc Plated)
4	Diaphragm	Reinforced EPDM
5	Body Seat	1/2" and 3/4" Models Polyphenylene Ether
		1" through 2" Models Polysulfone
6	Seat Disc	EPDM
7	Piston	Stainless Steel/Brass
8	Strainer Screen	Stainless Steel
9	O-ring	EPDM

SharkBite Union Materials	
Body	Lead-Free ¹ DZR Brass
O-ring	EPDM
Grab Ring	Stainless-Steel Tube Support
Liner	Polysulfone

¹ Lead free for all models. Surfaces that are in contact with consumable water contain less than 0.25% lead by weight.

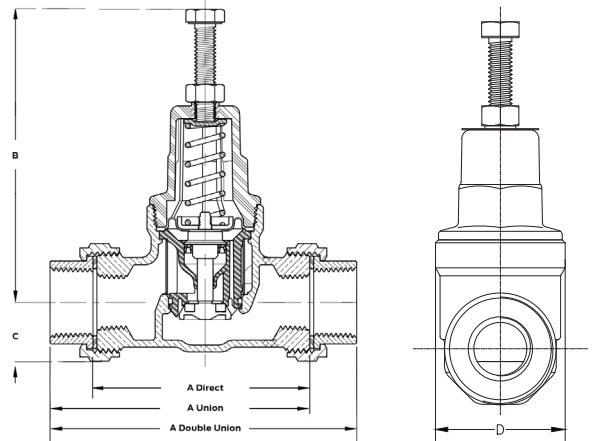

Dimensions (inches)							
Size	Connection Style	A			B	C	D
		Direct	Single Union	Double Union			
1/2"	NPT	3-1/4	4	4-3/4	4-3/8	3/4	1-47/64
	Sweat	-	4	4-3/4	4-3/8	3/4	1-47/64
	Cold Expansion	-	-	5-7/16	4-3/8	3/4	1-47/64
	SharkBite Slip	6-51/64	-	5-57/64	4-3/8	3/4	1-47/64
3/4"	NPT	3-7/16	4-3/16	4-15/16	4-3/8	3/4	1-47/64
	Sweat	-	4-5/16	5-1/4	4-3/8	3/4	1-47/64
	CPVC	-	-	5-3/8	4-3/8	3/4	1-47/64
	Barb	-	-	5-11/16	4-3/8	3/4	1-47/64
1"	Cold Expansion	-	-	6-3/32	4-3/8	3/4	1-47/64
	SharkBite Slip	7-5/8	-	7-3/64	4-3/8	3/4	1-47/64
	NPT	4-3/16	5-3/16	6-3/16	4-3/8	3/4	2-1/8
	Sweat	-	-	6-7/16	4-3/8	1	2-1/8
1-1/4"	CPVC	-	-	6-1/2	4-3/8	1	2-1/8
	Barb	-	-	7	4-3/8	1	2-1/8
	Cold Expansion	-	-	7-7/16	4-11/32	1-3/64	2-1/8
	SharkBite	6	-	8-45/64	4-11/32	1-3/64	2-1/8
1-1/2"	NPT	4-3/16	5-11/16	6-9/16	7-11/16	1-3/8	3-7/64
	Sweat	-	5-7/8	6-15/16	7-11/16	1-3/8	3-7/64
	Cold Expansion	-	-	8-19/32	7-49/64	1-11/32	3-7/64
	SharkBite	9-27/64	-	-	7-49/64	63/64	3-7/64
2"	NPT	4-3/16	5-15/16	7	7-11/16	1-5/8	3-5/32
	Sweat	-	6	7-3/16	7-11/16	1-5/8	3-5/32
	Cold Expansion	-	-	8-61/64	7-49/64	1-37/64	3-5/32
	NPT	4-3/16	6	7-3/16	7-11/16	1-7/8	3-11/16
2"	Sweat	-	6-1/4	7-11/16	7-11/16	1-7/8	3-11/16
	Cold Expansion	-	-	10	7-49/64	1-27/32	3-11/16

Cash Acme EB45 Flow Capacity

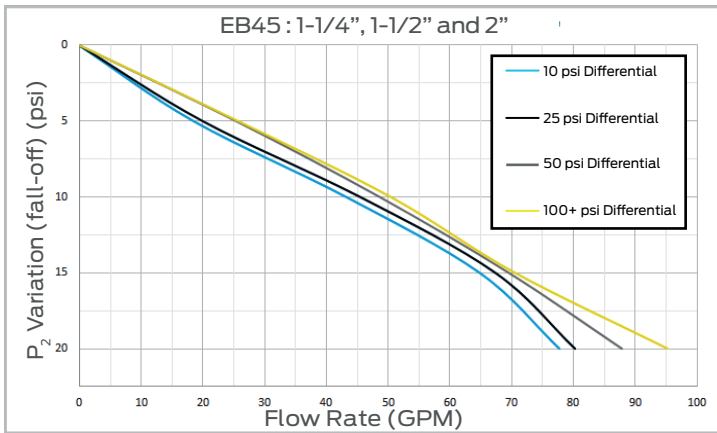
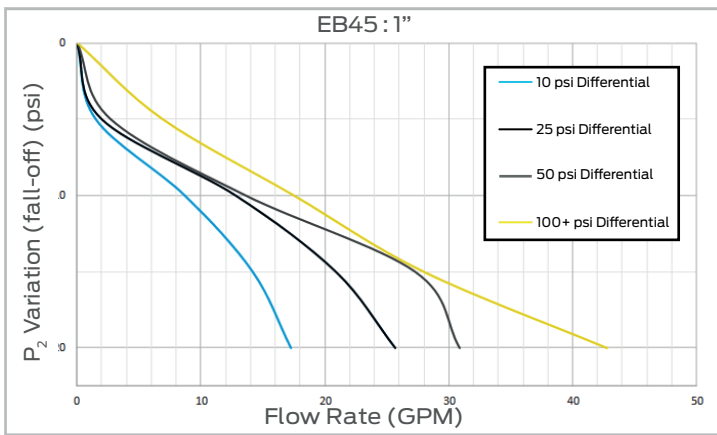
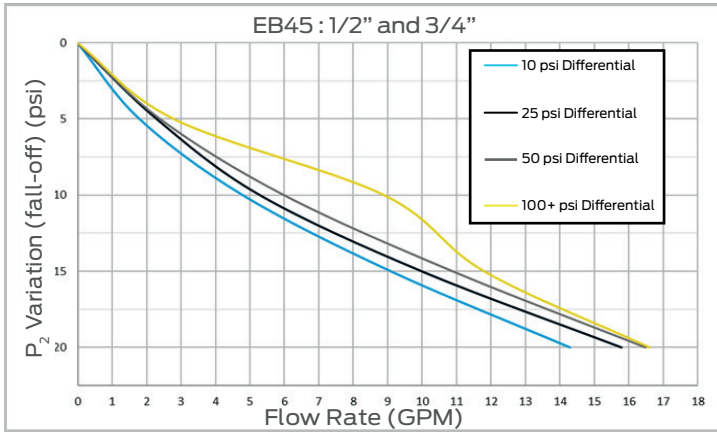

Pressure Differential: Difference between the inlet pressure and the PRV set pressure.

P₂ Variation: Pressure reduction of the outlet due to the demand created downstream when a fixture is opened and water is allowed to flow through the PRV.

Cash Acme PRV Cavitation Chart

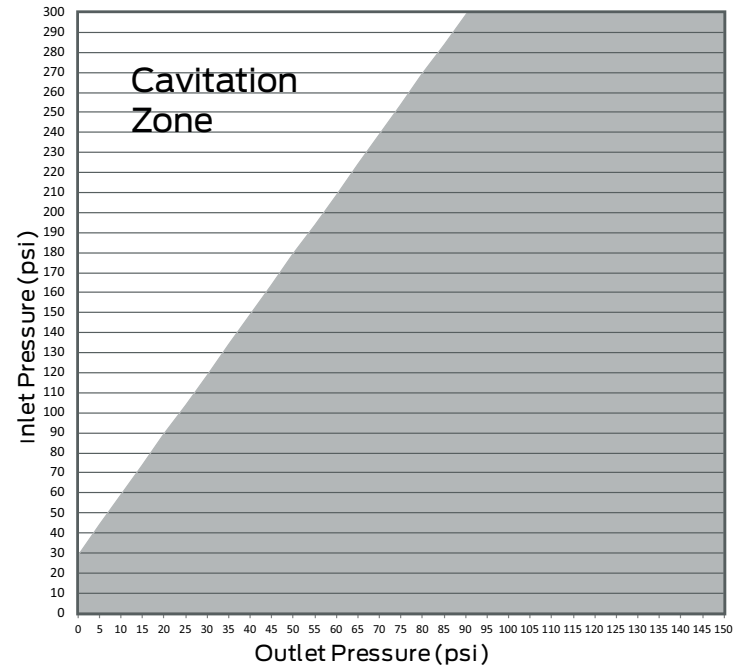

Certifications & Listings

ASSE 1003, CSA B356, NSF/ANSI/CAN 372, NSF/ANSI/CAN 61



Refer to local plumbing code

Product Submittal

Name	
Date	
Architect/Owner	
Contractor	
Tag	
Notes	