

# AprilAire®

## Radon

# Mitigation Fan

## ARN15F



### RADON MITIGATION FAN

AprilAire® fans are specifically designed for radon mitigation. AprilAire Fans provide superb performance, and run ultra-quiet. The ARN15F is ideal for most sub-slab radon mitigation systems with a basement or slab size up to **1500 square feet\***.

### FEATURES

- Energy efficient
- Ultra-quiet operation
- Meets all electrical code requirements
- Housing that stays white
- Water-hardened motorized impeller
- Seams sealed to inhibit radon leakage (ARN15F double snap sealed)
- ETL Listed - for indoor or outdoor use
- Thermally protected motor
- Rated for commercial and residential use

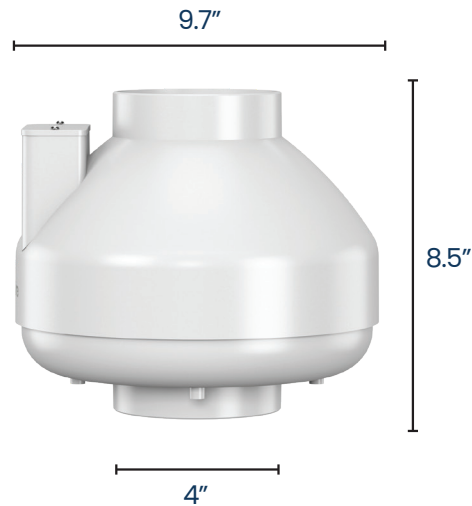

MODEL	FAN DUCT DIAMETER	WATTS	RECOM. MAX. OP. PRESSURE "WC	TYPICAL CFM VS. STATIC PRESSURE WC					
				0"	0.5"	1.0"	1.5"	2.0"	3.0"
ARN15F	4"	41-72	1.7	166	126	82	41	3	-



with U.S. and imported parts.



ETL Listed



All AprilAire Radon Mitigation Fans are covered by our 5-year, hassle-free warranty.

\*Other factors play into fan selection, such as soil/grade type, home construction, etc.

# AprilAire®

## Radon

# Mitigation Kit & Accessories

## RADON MITIGATION KIT – 15F

Everything you need to set up radon mitigation and monitoring in homes. Includes a 4x3 coupling, manometer, and the ARNALM Radon System Alarm.

P/N ARN15K



## RADON TEST KIT

Make radon testing a part of your service and maintenance calls. Available in single packs and 2-packs.

P/N ARNTK1 (1-Pack)  
P/N ARNTK2 (2-Pack)



## RADON SYSTEM ALARM

Install the Radon System Alarm to ensure that the mitigation system is performing without issue.

P/N ARNALM

