



24,000 BTU/H CEILING CASSETTE

SUBMITTAL COVER SHEET

PROJECT NAME _____

LOCATION _____

ARCHITECT _____

ENGINEER _____

CONTRACTOR _____

REFERENCE _____

SUBMITTED BY _____ DATE _____

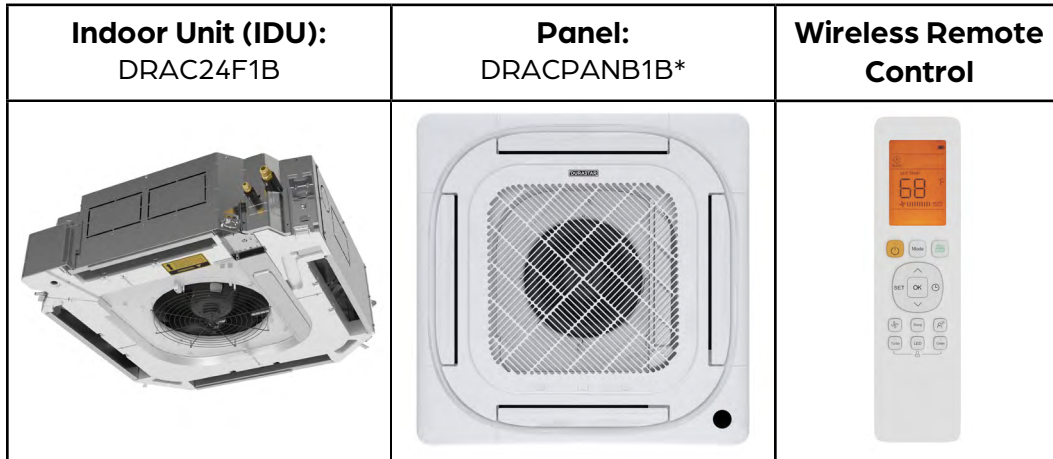

PRODUCT FEATURES

- Wireless Remote Control with "Follow Me" Technology
- Single or Multizone compatible
- High efficiency SEER rating, up to 20.7
- *Panel sold separately

SPECIFICATIONS		
Cooling Capacity (BTU/hr)	24000	
Heating Capacity (BTU/hr)	24000	
Voltage/Phase/Frequency	208-230V, 1 Phase, 60 Hz	
Voltage Range	187-253V	
Indoor Unit Air Flow (CFM)	Low	547
	Medium	635
	High	706
Drain Port O.D. / Drain Hose I.D.	Ø1" (Ø25mm)	
Drain Pump Lift	29 1/2"	
Sound Pressure (dB(A))	Low	43
	Medium	46
	High	49

LINE SET REQUIREMENTS	
Connection Type	Flare
Liquid	Ø3/8" (Ø9.52mm)
Gas	Ø5/8" (Ø15.87mm)

DIMENSIONS AND WEIGHT		
Unit Dimensions	Width	32 11/16"
	Depth	32 11/16"
	Height	8 1/16"
Carton Dimensions	Width	35 13/16"
	Depth	35 13/16"
	Height	9 13/16"
Net Weight	47 lbs.	
Gross Weight	55 lbs.	



Specifications are subject to change without notice.
 © 2022 Ferguson Enterprises LLC
 www.durastar.com



24,000 BTU/H CEILING CASSETTE

IDU DIMENSIONS - DRAC24F1B

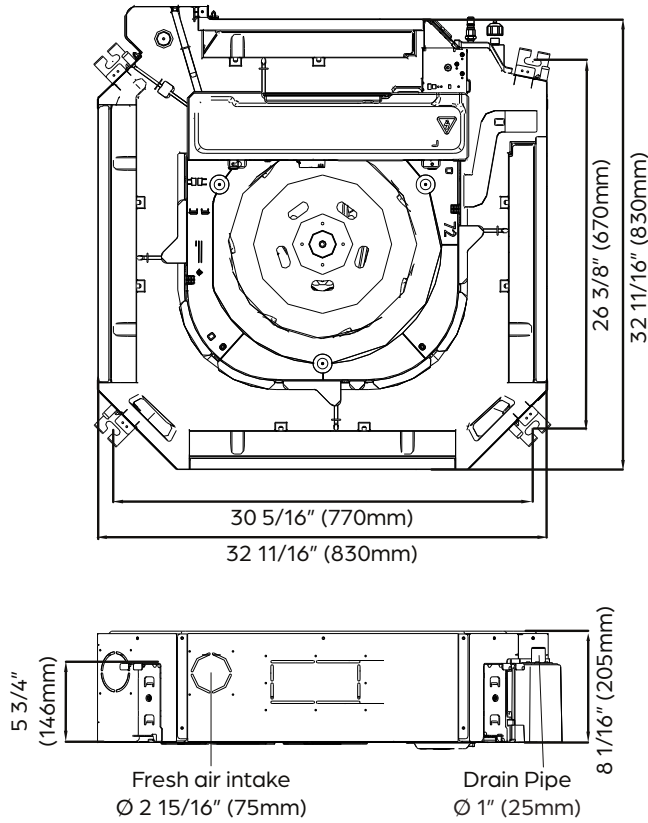

DRACPANB1B:

