

Revision A:

- MSZ-WR09/12NA - U2 have been added.

OBB818 is void.

INDOOR UNIT

**No. OBB818
REVISED EDITION-A**

PARTS CATALOG

Models

MSZ-WR09NA - U1, U2

MSZ-WR12NA - U1, U2

MSZ-WR18NA - U1

MSZ-WR24NA - U1



MSZ-WR24NA



CONTENTS

1. SERVICE PARTS LIST 2
2. OPTIONAL PARTS 13

SERVICE MANUAL (OBH818)

1

SERVICE PARTS LIST

MSZ-WR09NA MSZ-WR12NA

1-1. INDOOR UNIT STRUCTURAL PARTS

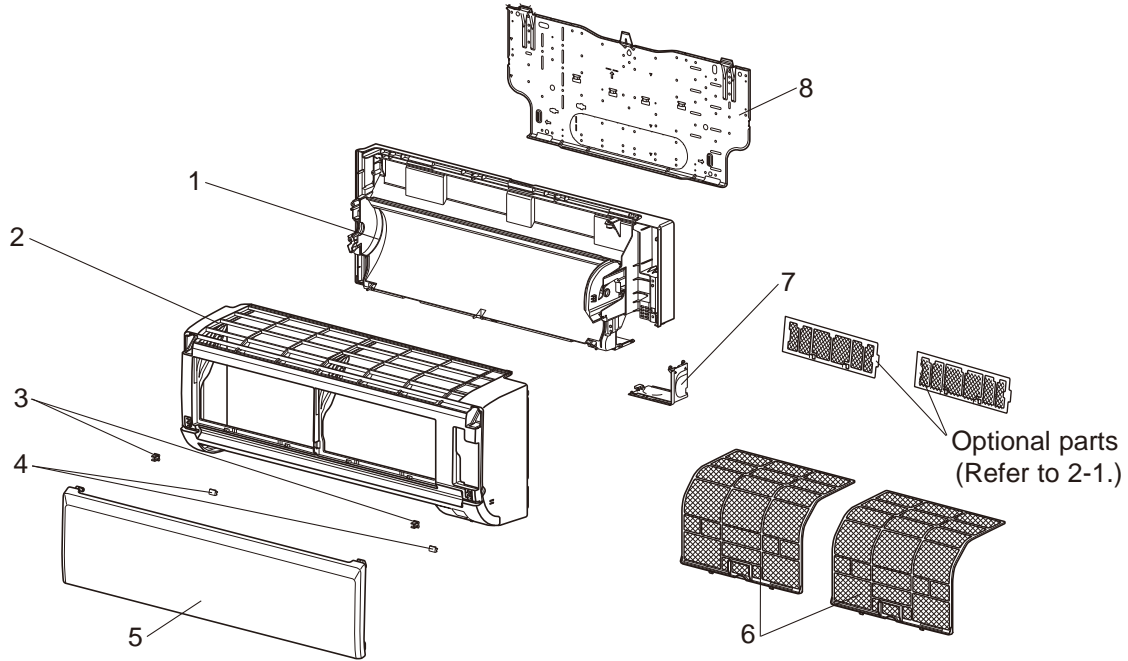

1-2. ACCESSORY AND REMOTE CONTROLLER



MSZ-WR09NA MSZ-WR12NA

1-1. INDOOR UNIT STRUCTURAL PARTS

1. The part quantity below indicates the required number of pieces per unit.

No.	Part No.	Part name	MSZ-WR09NA - U1	MSZ-WR09NA - U2	MSZ-WR12NA - U1	MSZ-WR12NA - U2	Symbol in Wiring Diagram	Remarks
1	U01 A01 234	BOX ASSEMBLY	1	1	1	1		
2	U01 A03 000	PANEL ASSEMBLY	1	1	1	1		Includes No. 3, 4 and 5
3	U01 A01 142	CATCH	2	2	2	2		2 PCS/SET
4	U01 A01 067	SCREW CAP	2	2	2	2		2 PCS/SET
5	U01 A03 010	FRONT PANEL	1	1	1	1		
6	U01 A02 100	ANTI MOLD FILTER	2	2	2	2		1 PC/SET
7	U01 A01 975	CORNER BOX RIGHT	1	1	1	1		
8	U01 A01 970	INSTALLATION PLATE	1	1	1	1		

1-2. ACCESSORY AND REMOTE CONTROLLER

1. The part quantity below indicates the required number of pieces per unit.

No.	Part No.	Part name	MSZ-WR09NA - U1	MSZ-WR09NA - U2	MSZ-WR12NA - U1	MSZ-WR12NA - U2	Symbol in Wiring Diagram	Remarks
9	U01 A05 426	REMOTE CONTROLLER	1	1	1	1		MS16A

MSZ-WR09NA MSZ-WR12NA

1-3. INDOOR UNIT ELECTRICAL PARTS AND FUNCTIONAL PARTS

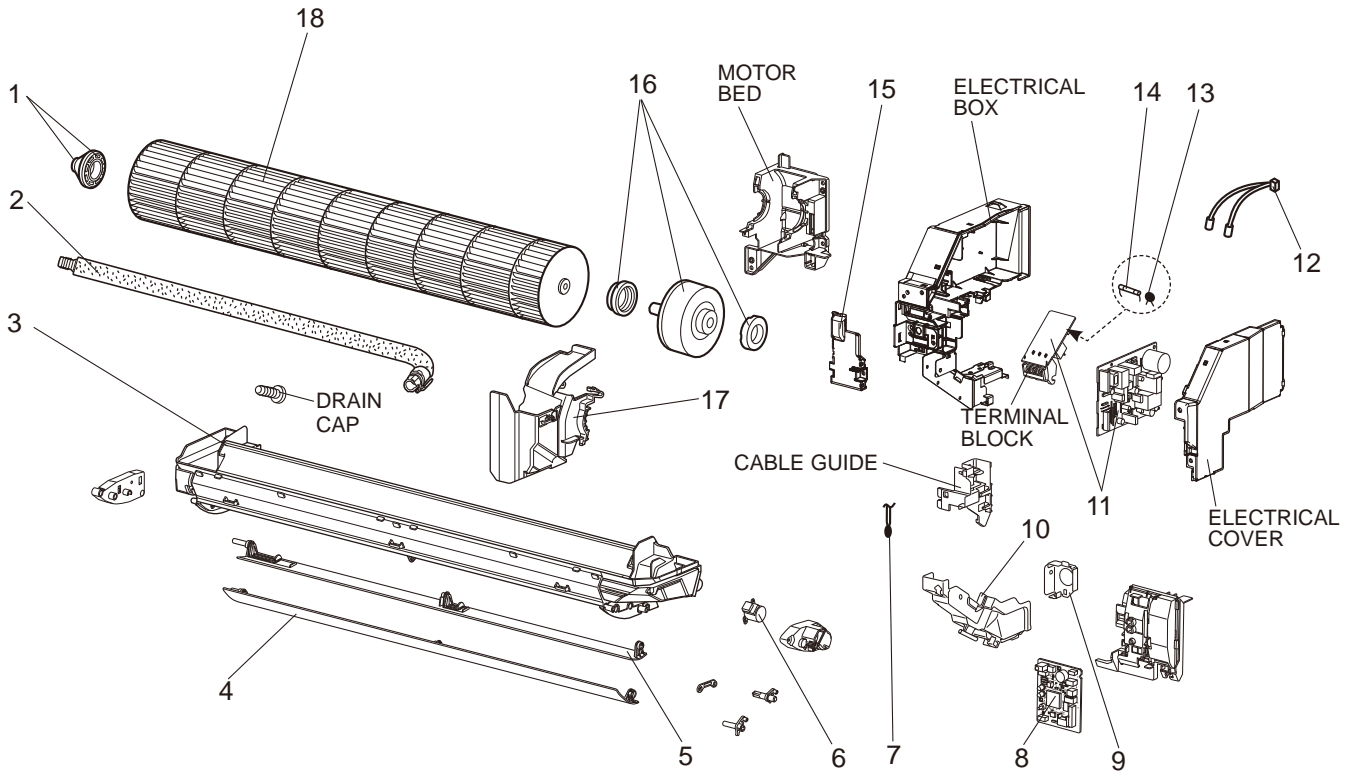

MSZ-WR09NA MSZ-WR12NA

1-3. INDOOR UNIT ELECTRICAL PARTS AND FUNCTIONAL PARTS

1. The part quantity below indicates the required number of pieces per unit.

No.	Part No.	Part name	MSZ-WR09NA - U1	MSZ-WR09NA - U2	MSZ-WR12NA - U1	MSZ-WR12NA - U2	Remarks
1	U01 A02 510	BEARING MOUNT ASSEMBLY	1	1	1	1	Includes sleeve bearing
2	U01 A01 702	DRAIN HOSE	1	1	1	1	
3	U01 A01 235	NOZZLE ASSEMBLY	1	1	1	1	
4	U01 A01 040	VANE-UPPER	1	1	1	1	
5	U01 A01 041	VANE-LOWER	1	1	1	1	
6	U01 A01 303	VANE MOTOR	1	1	1	1	MV UP & DOWN
7	U01 A01 308	ROOM TEMPERATURE THERMISTOR	1		1		RT11
7	U01 A08 308	ROOM TEMPERATURE THERMISTOR		1		1	
8	U01 A32 452	ELECTRONIC CONTROL P.C. BOARD	1				
8	U01 A52 452	ELECTRONIC CONTROL P.C. BOARD		1			
8	U01 A33 452	ELECTRONIC CONTROL P.C. BOARD			1		
8	U01 A53 452	ELECTRONIC CONTROL P.C. BOARD				1	
9	U01 A04 978	CONDUIT PLATE	1	1	1	1	
10	U01 A01 979	CONDUIT COVER	1	1	1	1	
11	U01 A01 440	POWER P.C. BOARD	1		1		Includes TERMINAL BLOCK with TERMINAL P.C. BOARD
11	U01 A03 440	POWER P.C. BOARD		1		1	
12	U01 A04 307	INDOOR COIL THERMISTOR	1		1		RT12, RT13
12	U01 A09 308	INDOOR COIL THERMISTOR		1		1	RT12, RT13
13	U01 A01 385	VARISTOR	1	1	1	1	NR11
14	U01 A01 382	FUSE	1		1		F11 T3.15AL250V
14	U01 001 239	FUSE		1		1	F11 T3.15AL250V
15	U01 A01 784	V.A. CLAMP	1	1	1	1	
16	U01 A01 300	INDOOR FAN MOTOR	1	1	1	1	MF RC0J30-□□, Includes FAN MOTOR RUBBER MOUNT (2 PCS/SET)
17	U01 A01 333	MOTOR BAND	1	1	1	1	
18	U01 A01 302	LINE FLOW FAN	1	1	1	1	

MSZ-WR09NA MSZ-WR12NA
1-4. INDOOR UNIT HEAT EXCHANGER

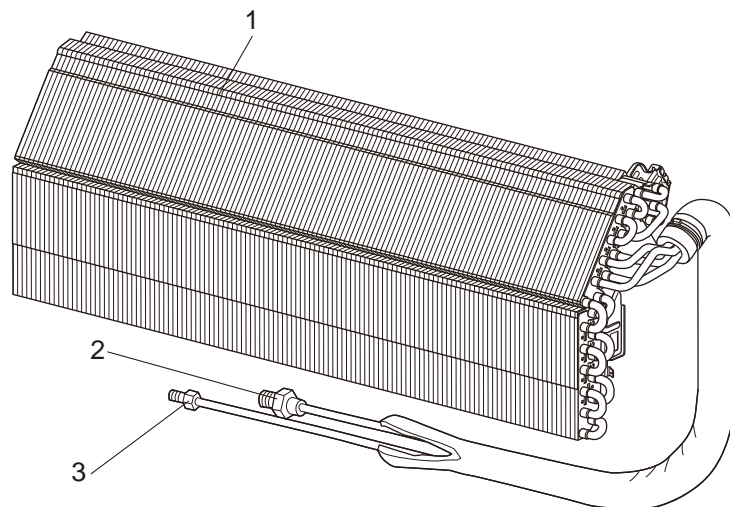

MSZ-WR09NA MSZ-WR12NA
1-4. INDOOR UNIT HEAT EXCHANGER

1. The part quantity below indicates the required number of pieces per unit.

No.	Part No.	Part name	MSZ-WR09NA - U1	MSZ-WR09NA - U2	MSZ-WR12NA - U1	MSZ-WR12NA - U2	Symbol in Wiring Diagram	Remarks
1	U01 A03 620	INDOOR HEAT EXCHANGER	1	1	1	1		
2	U01 A01 666	UNION GAS	1	1	1	1		ø3/8 (ø9.52)
3	U01 A01 667	UNION LIQUID	1	1	1	1		ø1/4 (ø6.35)

MSZ-WR18NA MSZ-WR24NA
1-5. INDOOR UNIT STRUCTURAL PARTS

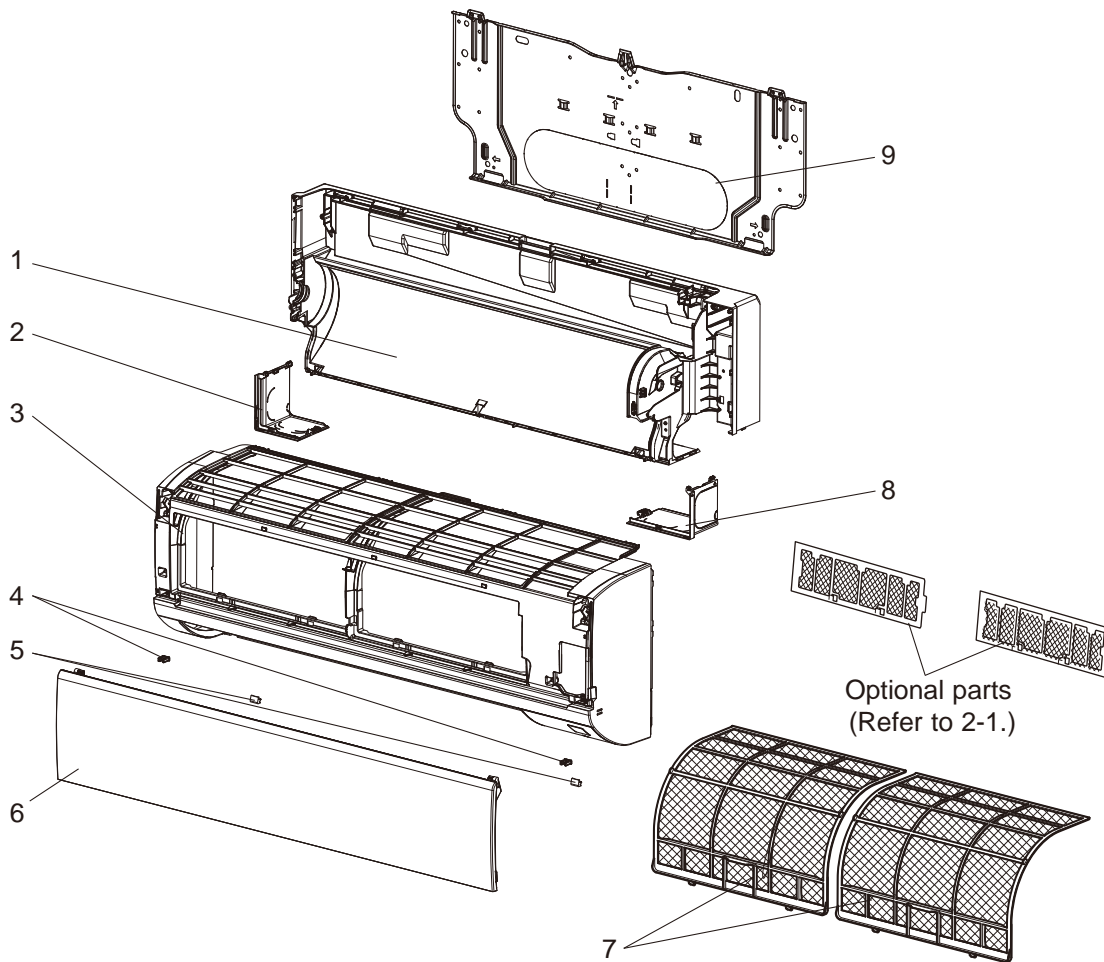

1-6. ACCESSORY AND REMOTE CONTROLLER



MSZ-WR18NA MSZ-WR24NA

1-5. INDOOR UNIT STRUCTURAL PARTS

1. The part quantity below indicates the required number of pieces per unit.

No.	Part No.	Part name	MSZ-WR18NA - U1	MSZ-WR24NA - U1	Symbol in Wiring Diagram	Remarks
1	E22 N87 234	BOX ASSEMBLY	1	1		
2	E22 N87 976	CORNER BOX LEFT	1	1		
3	E22 P88 000	PANEL ASSEMBLY	1	1		Includes No. 4, 5 and 6
4	E22 F95 142	CATCH	2	2		2 PCS/SET
5	E22 913 067	SCREW CAP	2	2		2 PCS/SET
6	E22 P88 010	FRONT PANEL	1	1		
7	E22 N87 100	AIR FILTER	2	2		1 PC/SET
8	E22 N87 975	CORNER BOX RIGHT	1	1		
9	E22 N87 970	INSTALLATION PLATE	1	1		

1-6. ACCESSORY AND REMOTE CONTROLLER

1. The part quantity below indicates the required number of pieces per unit.

No.	Part No.	Part name	MSZ-WR18NA - U1	MSZ-WR24NA - U1	Symbol in Wiring Diagram	Remarks
10	E22 P88 426	REMOTE CONTROLLER	1	1		MS16A

MSZ-WR18NA MSZ-WR24NA

1-7. INDOOR UNIT ELECTRICAL PARTS AND FUNCTIONAL PARTS

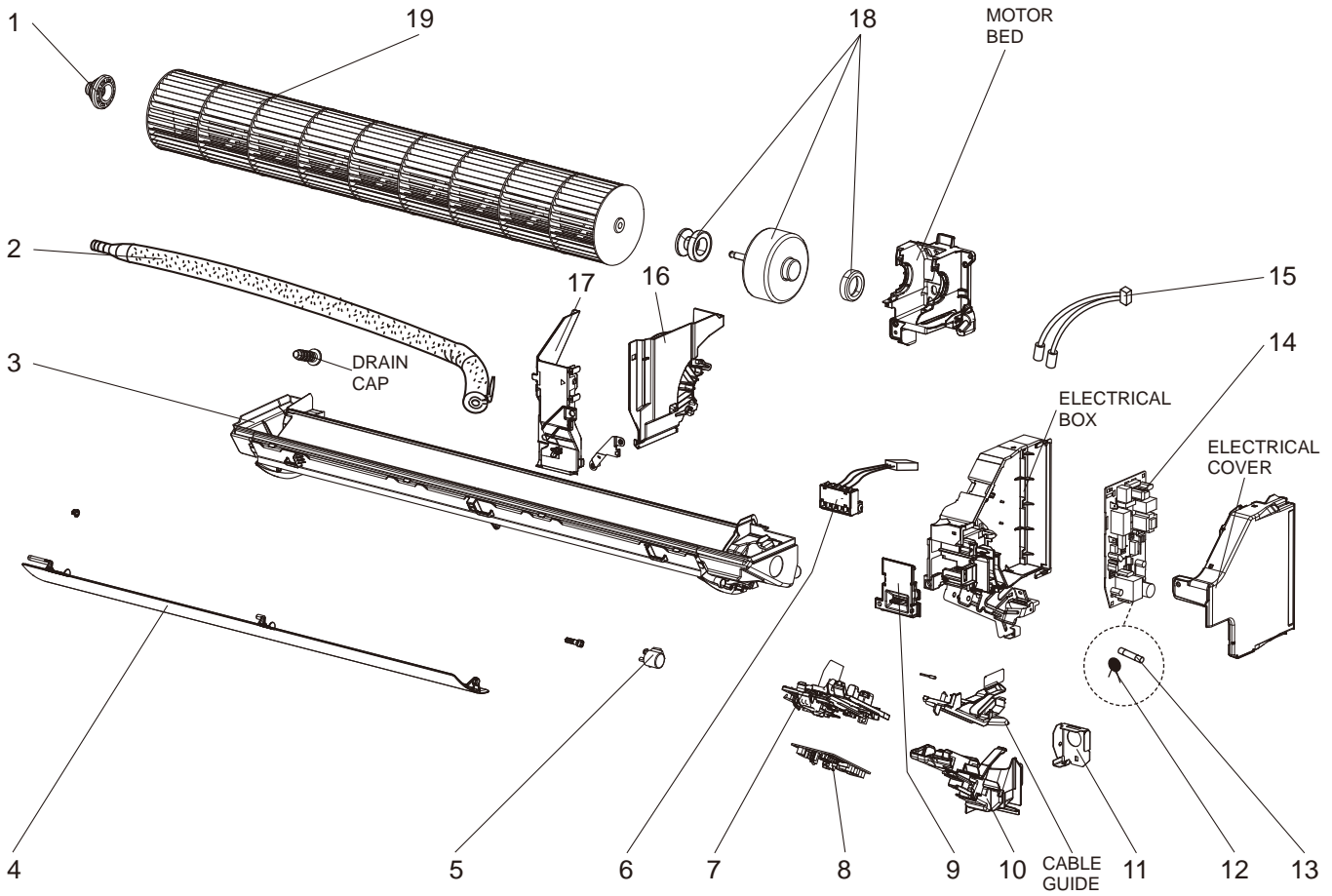

MSZ-WR18NA MSZ-WR24NA

1-7. INDOOR UNIT ELECTRICAL PARTS AND FUNCTIONAL PARTS

1. The part quantity below indicates the required number of pieces per unit.

No.	Part No.	Part name	MSZ-WR18NA - U1	MSZ-WR24NA - U1	Symbol in Wiring Diagram	Remarks
1	E22 A89 509	BEARING MOUNT	1	1		
2	E22 P72 702	DRAIN HOSE	1	1		
3	E22 P88 235	NOZZLE ASSEMBLY	1	1		
4	E22 N87 040	HORIZONTAL VANE	1	1		
5	E22 N87 303	VANE MOTOR (HORIZONTAL)	1	1	MV	UP & DOWN
6	E22 N94 375	TERMINAL BLOCK ASSEMBLY	1	1	TB	
7	E22 N87 095	CONTROL P.C. BOARD HOLDER ASSEMBLY	1	1		
8	E22 22B 452	ELECTRONIC CONTROL P.C. BOARD	1			Includes ROOM TEMPERATURE THERMISTOR (RT11)
8	E22 23B 452	ELECTRONIC CONTROL P.C. BOARD		1		Includes ROOM TEMPERATURE THERMISTOR (RT11)
9	E22 N87 784	V.A. CLAMP	1	1		
10	E22 N94 979	CONDUIT COVER	1	1		
11	E22 N94 978	CONDUIT PLATE	1	1		
12	E22 B75 385	VARISTOR	1	1	NR11	
13	E22 A49 382	FUSE	1	1	F11	T3.15AL250V
14	E22 N94 440	POWER P.C. BOARD	1	1		
15	E22 N87 307	INDOOR COIL THERMISTOR	1	1	RT12,RT13	
16	E22 N87 333	MOTOR BAND	1	1		
17	E22 N87 541	WATER COVER	1	1		
18	E22 L74 300	INDOOR FAN MOTOR	1		MF	RC0J30-□□, Includes FAN MOTOR RUBBER MOUNT (2 PCS/SET)
18	E22 J44 300	INDOOR FAN MOTOR		1	MF	RC0J30-□□, Includes FAN MOTOR RUBBER MOUNT (2 PCS/SET)
19	E22 N87 302	LINE FLOW FAN	1	1		

MSZ-WR18NA MSZ-WR24NA
1-8. INDOOR UNIT HEAT EXCHANGER

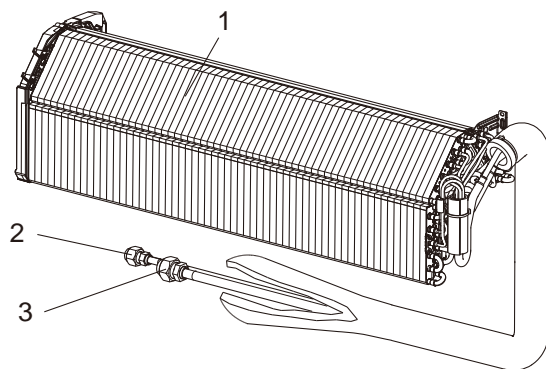

1. The part quantity below indicates the required number of pieces per unit.

No.	Part No.	Part name	MSZ-WR18NA - U1	MSZ-WR24NA - U1	Symbol in Wiring Diagram	Remarks
1	E22 28E 620	INDOOR HEAT EXCHANGER	1			
1	E22 31E 620	INDOOR HEAT EXCHANGER		1		
2	E22 151 667	UNION (LIQUID)	1			ø 1/4 (ø 6.35)
2	E22 151 666	UNION (LIQUID)		1		ø 3/8 (ø 9.52)
3	E22 179 667	UNION (GAS)	1			ø 1/2 (ø 12.7)
3	E22 527 666	UNION (GAS)		1		ø 5/8 (ø 15.88)

2-1. AIR CLEANING FILTER

Every 3 months:

- Remove dirt by a vacuum cleaner.

When dirt cannot be removed by vacuum cleaning:

- Soak the filter and its frame in lukewarm water before rinsing it.
- After washing, dry it well in shade.

Every year:

- Replace it with a new air cleaning filter for best performance.

NOTE 1: Clean the filters regularly for best performance and to reduce power consumption.

NOTE 2: Dirty filters cause condensation in the air conditioner which will contribute to the growth of fungi such as mold. It is therefore recommended to clean air filters every 2 weeks.

(ANTI-ALLERGY ENZYME FILTER)

Model	Part No.
MSZ-WR09NA MSZ-WR12NA MSZ-WR18NA MSZ-WR24NA	MAC-408FT-E

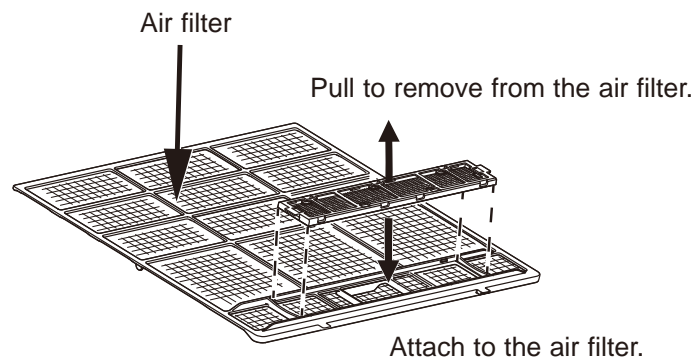

mitsubishi electric corporation

HEAD OFFICE: TOKYO BUILDING, 2-7-3, MARUNOUCHI, CHIYODA-KU, TOKYO 100-8310, JAPAN

© Copyright 2018 MITSUBISHI ELECTRIC CORPORATION

Issued: Feb. 2022. No. OBB818 REVISED EDITION-A

Published: Sep. 2018. No. OBB818

Made in Japan

Specifications are subject to change without notice.