

Elite VWH

Premier Hot Water Supply Boiler

10:1
Turndown
Ratio

Up to
98%

Energy Star Rated
Gas Fired Volume
Water Heater

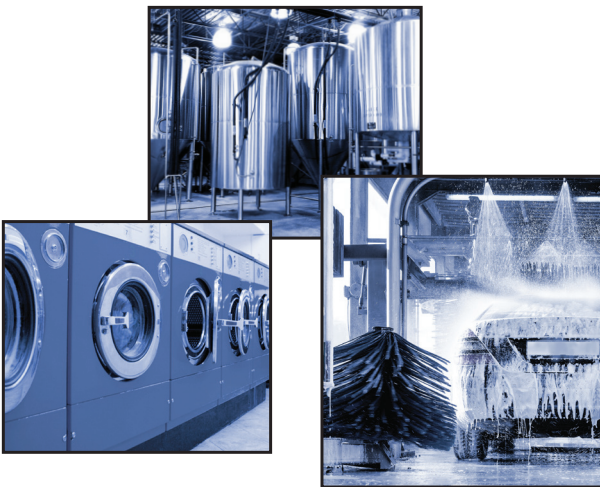

www.htproducts.com



Advanced Heating
& Hot Water Systems

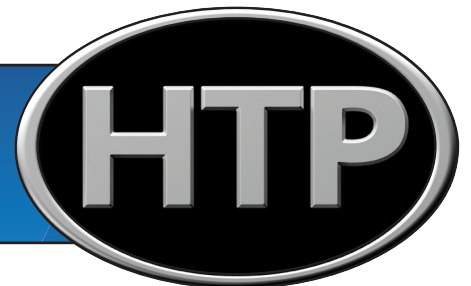

Elite VWH

Premier Hot Water Supply Boiler



Top 10 Features

Advanced modulating
10 to 1 turndown ratio

Up to 98% efficient

Durable 316L stainless
steel heat exchanger

Vents in inexpensive PVC pipe,
up to 200 equivalent feet

Available in
LP or Natural Gas

Eco-friendly and low
NOx combustion system

Total System Control
interface: a 2-line
20-character LCD

Impressive range: 4 models,
ranging from 220,000 to
399,000 Btuh

Floor standing
or wall mount

Cascade up to 8 units

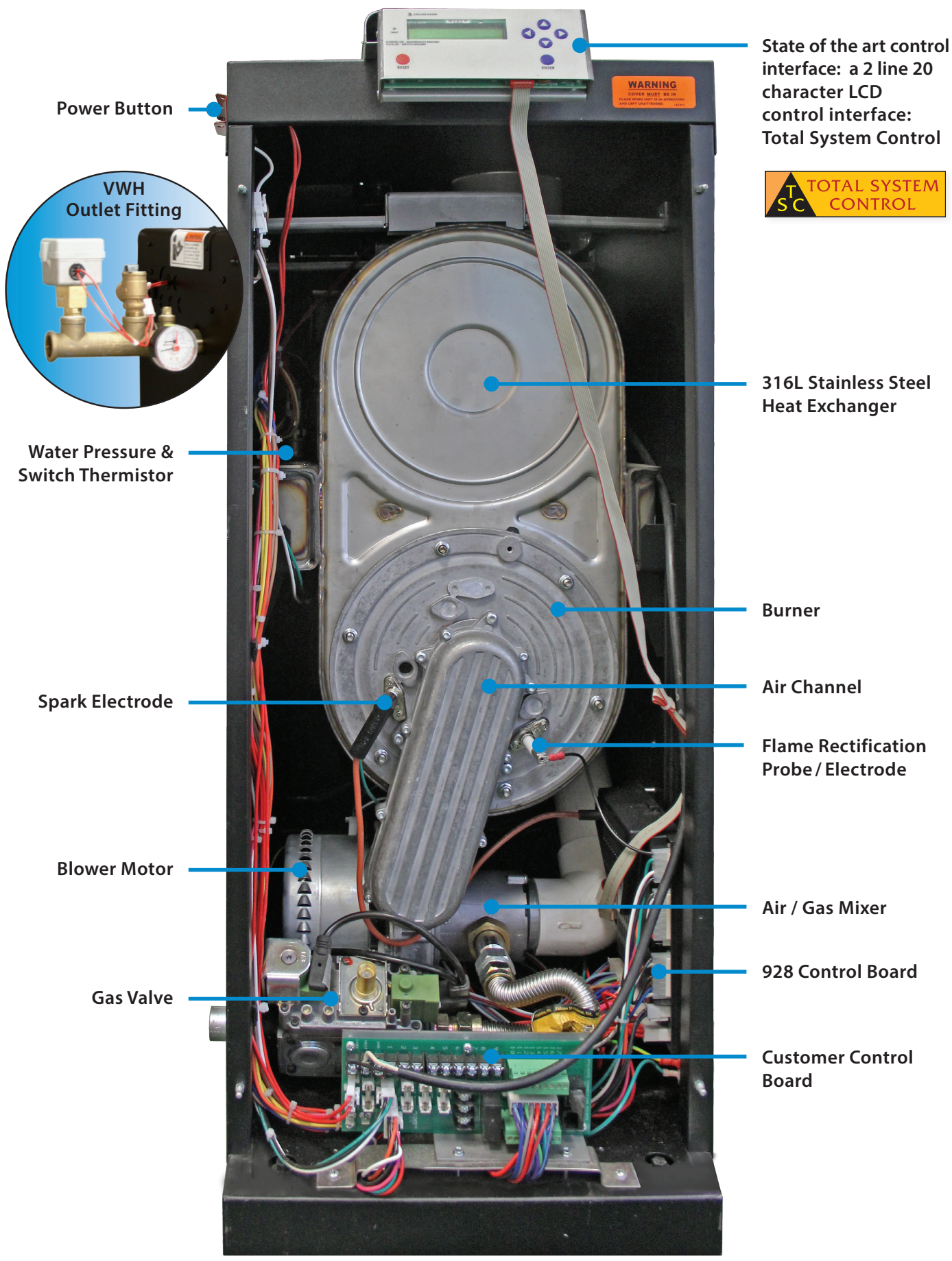

Power Button

State of the art control interface: a 2 line 20 character LCD control interface: Total System Control

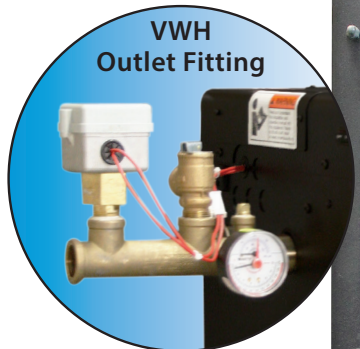

VWH Outlet Fitting

316L Stainless Steel Heat Exchanger

Water Pressure & Switch Thermistor

Burner

Spark Electrode

Air Channel

Flame Rectification Probe / Electrode

Blower Motor

Air / Gas Mixer

Gas Valve

928 Control Board

Customer Control Board

Elite VWH

Premier Hot Water Supply Boiler

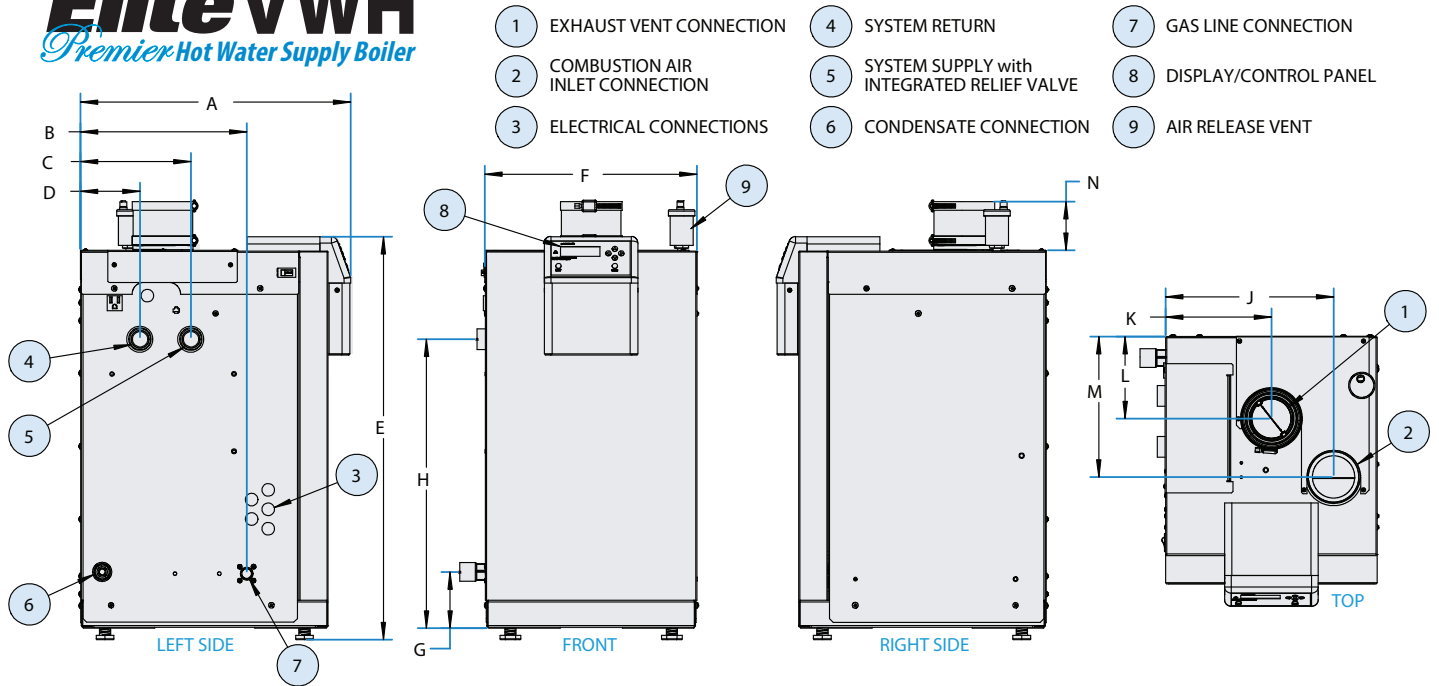

MODELS*	A	B	C	D	E	F	G	H	J	K	L	M	N	Shipping Weight	Energy Star	GPS @ 100° Rise
EP-220 VWH	26.5"	19.5"	15.5"	6.0"	24.25"	14.5"	4.5"	20.0"	11.75"	7.38"	4.25"	8.25"	4.0"	164 lbs.	95%	254

*"N" DENOTES NATURAL GAS
 "LP" DENOTES PROPANE
 ALL DIMENSIONS ARE APPROXIMATE
 AND ARE SUBJECT TO CHANGE

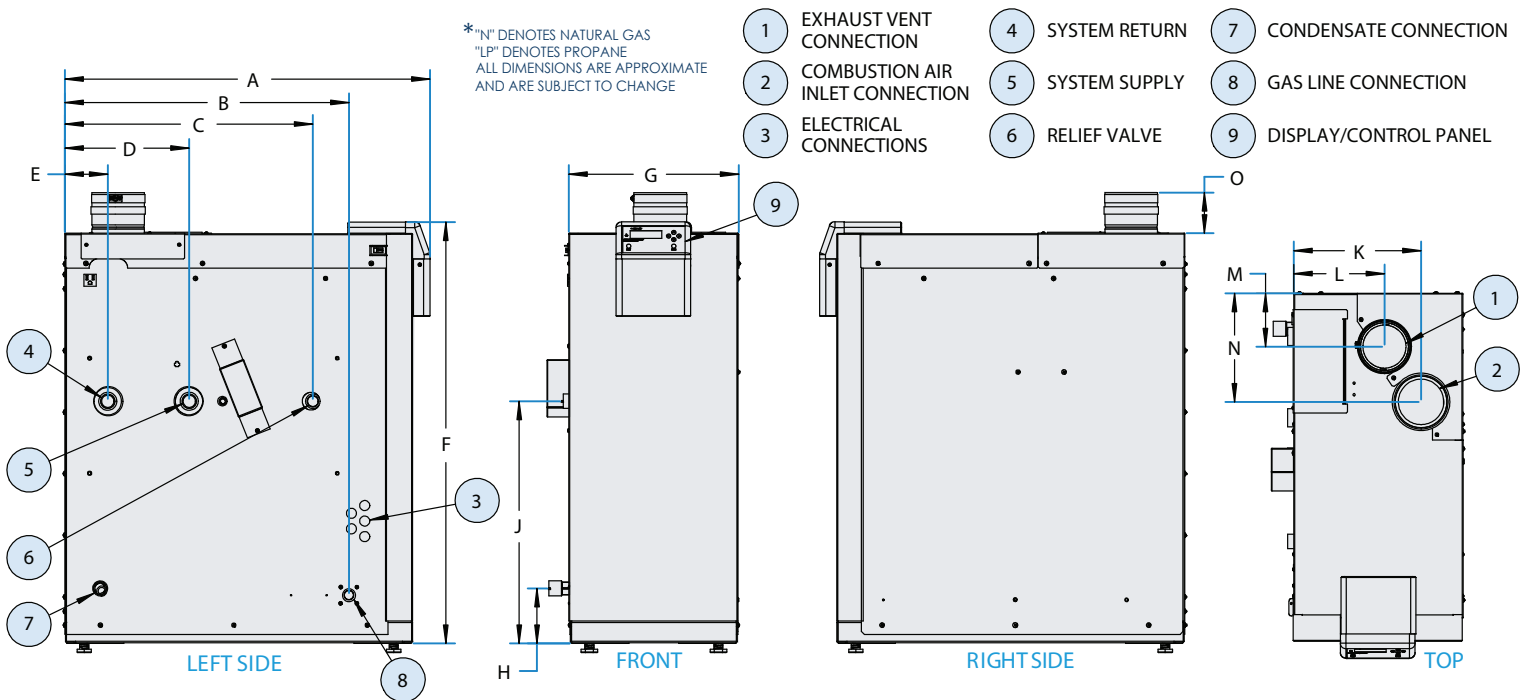

MODELS*	A	B	C	D	E	F	G	H	J	K	L	M	N	O	Shipping Weight	Energy Star	GPS @ 100° Rise
EP-299 VWH	24.75"	17.5"	14.5"	7.38"	3.25"	36.5"	14.5"	4.75"	21.0"	11.0"	7.88"	4.63"	9.25"	3.5"	211 lbs.	96%	347
EP-301 VWH	24.75"	17.5"	14.5"	7.38"	3.25"	36.5"	14.5"	4.75"	21.0"	11.0"	7.88"	4.63"	9.25"	3.5"	211 lbs.	95%	347
EP-399 VWH	31.75"	24.75"	21.5"	10.75"	3.75"	36.5"	14.5"	4.75"	21.0"	11.0"	7.88"	4.63"	9.25"	3.5"	256 lbs.	98%	461

WHAT'S IN THE BOX

- Temperature & Pressure Gauge
- Pressure Relief Valve
- Intake PVC Tee with Screens
- Exhaust PVC Coupling with Screens
- Outlet Combination Fitting
- Flow Switch and Paddles
- Installation Manual
- Warranty

