

June 2023

# Spence D Series Pressure Reducing Pilot



## WARNING

Failure to follow these instructions or to properly install and maintain this equipment could result in an explosion, fire and/or chemical contamination causing property damage and personal injury or death.

Emerson regulator must be installed, operated and maintained in accordance with federal, state and local codes, rules and regulations and Emerson Process Management Regulator Technologies, Inc. (Emerson) instructions.

If the regulator vents gas or a leak develops in the system, service to the unit may be required. Failure to correct trouble could result in a hazardous condition.

Installation, operation and maintenance procedures performed by unqualified personnel may result in improper adjustment and unsafe operation. Either condition may result in equipment damage or personal injury. Only a qualified person shall install or service the Type D.



## WARNING

### CALIFORNIA PROPOSITION 65

This product can expose you to chemicals including lead and nickel which is known to the State of California to cause cancer, birth defects or other reproductive harm. For more information, go to [www.P65Warnings.ca.gov](http://www.P65Warnings.ca.gov).



Figure 1. D Series

## Introduction

### Scope of the Manual

This manual provides instructions for installation, maintenance and parts information for the D Series pressure reducing pilots.

### Product Description

Spence Pressure Regulator is a combination of D Series pilot and a Type E main valve. This regulator reduces a steady or varying initial pressure to a constant, adjustable delivery pressure.

# D Series

## Specifications

The Specifications section gives some general specifications for the D Series pilot. The nameplates give detailed information for a specific pilot as built in the factory.

### Available Configurations

**Type D:** For  $\pm 1$  psi / 0.07 bar control of delivery pressures between 3 and 150 psi / 0.21 and 10.3 bar.

**Type D2:** For control of delivery pressures between 100 and 300 psi / 6.90 and 20.7 bar.

**Type D5:** For  $\pm 1/2$  psi / 0.03 bar control of delivery pressures between 1 and 25 psi / 0.07 and 1.72 bar.

**Type D120:** Fast response controlling delivery pressures between 5 and 300 psi / 0.35 and 20.7 bar. Used on large Type E main valves.

### Maximum Inlet Temperature<sup>(1)</sup>

**Cast iron:** 450°F / 232°C

**Steel:** 750°F / 400°C

### Maximum Inlet Pressure<sup>(1)</sup>

**Cast iron:** 250 psig / 17.2 bar

**Steel:** 600 psig / 41.4 bar

### Pressure Ranges<sup>(1)</sup>

**Type D:** 3 to 150 psig / 0.21 to 10.3 bar

**Type D2:** 100 to 300 psig / 6.90 to 20.7 bar

**Type D5:** 1 to 25 psig / 0.07 to 1.72 bar

**Type D120:** 5 to 300 psig / 0.35 to 20.7 bar

### Construction Materials

**Body:** Cast iron, Steel

**Stem, Disk, Seat and Diaphragm:** Stainless steel

**Gasket:** Grafoil

**Spring:** Inconel®

### Approximate Weights

**Type D:** 7 lbs / 3.2 kg

**Type D2:** 10 lbs / 4.5 kg

**Type D5:** 14 lbs / 6.4 kg

**Type D120:** 16 lbs / 7.3 kg

### Optional Accessories

Spring Chamber

Adjusting Handwheel

Wall Bracket

Locking Device

Composition Disk

Integral Mount Body

Vacuum Spring Assembly

1. The pressure/temperature limits in this Instruction Manual or any applicable standard limitation should not be exceeded.

**Table 1. D Series Spring Pressure Ranges**

TYPE	PRESSURE RANGE, psig / bar	ADJUSTING SPRING		
		Wire Diameter, In. / mm	Part Number	Color
D	3 to 20 / 0.21 to 1.38 <sup>(1)</sup>	3/16 / 4.76	WAL05-05007-00	Aluminum
	5 to 50 / 0.35 to 3.45 <sup>(1)</sup>	1/4 / 6.35	WAL05-05003-00	Orange
	10 to 100 / 0.69 to 6.89	5/16 / 7.94	WAL05-05005-00	Green
	20 to 150 / 1.38 to 10.3	11/32 / 8.73	WAL05-05012-00	Black
D2	100 to 300 / 6.89 to 20.7	7/16 / 11.1	WAL05-04990-00	Aluminum
D5	1 to 10 / 0.07 to 0.69	3/16 / 4.76	WAL05-05007-00	Aluminum
	5 to 25 / 0.35 to 1.72	1/4 / 6.35	WAL05-05003-00	Orange
D120	5 to 25 / 0.35 to 1.72	7/32 / 5.56	WAL05-05016-00	Not Specified on Purchasing Specification, Item Details or Drawing.
	10 to 75 / 0.69 to 5.17	5/16 / 7.94	WAL05-05028-00	
	40 to 150 / 2.76 to 10.3	3/8 / 9.53	WAL05-05030-00	
	100 to 300 / 6.89 to 20.7	7/16 / 11.1	WAL05-04990-00	Aluminum

1. Vacuum Spring Assembly, minimum range is 30 in. Hg / 1.02 bar; maximum is reduced by 15 psig / 1.03 bar.

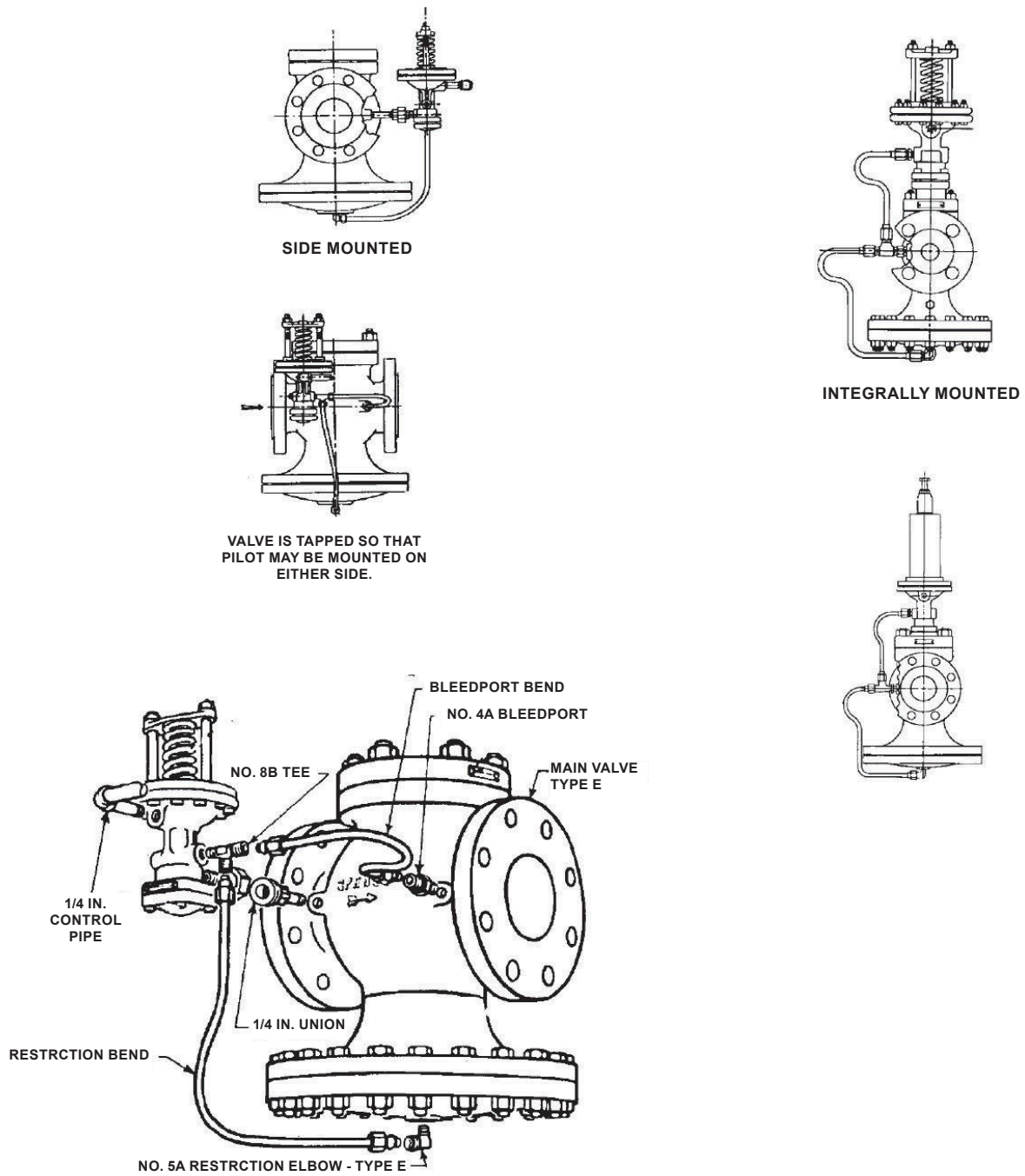

Figure 2. Typical Type ED Installation

# D Series

## Principle of Operation

The regulator is operated by initial steam or fluid pressure. It is normally closed, being held so by initial pressure on the disk and by an internal main spring.

When the pilot is opened, initial pressure flows through the pilot to the 8B tee. Bleedport 4A restricts the flow and pressure builds under the diaphragm and opens the main valve. The 5A restriction elbow steadies the operation of the regulator.

Delivery pressure feeds back through the control pipe to the pilot diaphragm. As this pressure approaches a balance with the air loading signal, the pilot throttles the loading pressure. In turn, the main valve takes a position established by the loading pressure where just enough steam flows to maintain the set delivery pressure.

## Installation



### WARNING

**Personal injury or system damage may result if this pilot is installed, without appropriate overpressure protection, where service conditions could exceed the limits given in the Specifications section and/or pilot nameplate.**

**Additionally, physical damage to the pilot may result in personal injury or property damage due to escaping of accumulated gas. To avoid such injury and damage, install the pilot in a safe location.**

**All pressure equipment should be installed in a non-seismic area; should not be exposed to fire; and should be protected from thunderbolt (lightning) strikes.**



### CAUTION

**The piping system must be adequately designed and supported to prevent extraordinary loads to the pressure equipment.**

## Planning

1. Locate the regulator in a horizontal pipe.
2. Provide a trap ahead of the regulator to prevent water hammer and erratic operation.

3. Use strainer to protect the regulator and avoid damaging effects of scale and dirt in pipelines.
4. Provide a three valve bypass to facilitate inspection of the regulator without interrupting service.

## Main Valve

1. Flush the main piping system thoroughly to clear it from welding beads, scale, sand, etc.
2. Mount main valve with diaphragm chamber down and arrow on body pointing in the direction of flow. Screwed end valve should be mounted in unions.

## Pilot

1. Mount the pilot on either side of the main valve by means of a 1/4 in. / 6.35 mm nipple and union provided. Make this connection to the 1/4 in. / 6.35 mm pipe tap on the inlet of the main valve.

### Note

**As a general rule of thumb, tighten 1.5 to 3 turns past hand tight all NPT connections and use thread sealant with a temperature range up to 450°F / 232°C.**

2. Screw 4A bleedport fitting into 1/8 in. / 3.18 mm pipe tap on the outlet of the main valve body.

### Note

**Bleed orifice in this fitting is vital to operation of regulator.**

3. Screw 8B tee into 1/8 in. / 3.18 mm pipe tap in pilot. Select tap facing downstream.
4. Screw 5A elbow containing restriction orifice into 1/8 in. / 3.18 mm pipe tap on underside of main valve diaphragm chamber. If initial pressure or pressure drop is less than 15 psi / 1.03 bar, a 5B open elbow without orifice is used.
5. Connect tubing bends as illustrated in Figure 2.

## Maintenance



### WARNING

**To avoid personal injury, property damage or equipment damage caused by sudden release of pressure or explosion of accumulated gas, do not attempt any maintenance or disassembly without first isolating the**

pilot from system pressure and relieving all internal pressure from the pilot.

Pilots that have been disassembled for repair must be tested for proper operation before being returned to service. Only parts manufactured by Emerson should be used for repairing this pilot.

Due to normal wear or damage that may occur from external sources, this pilot should be inspected and maintained periodically. The frequency of inspection and replacement of parts depends upon the severity of service conditions or the requirement of local, state and federal rules and regulations.

## Disassembly

1. Release adjusting spring (key 4) compression by loosening adjusting nuts (key 1). Remove nuts, yoke (key 2), adjusting spring and spring button (key 5).
2. Remove diaphragm nuts (key 15) and lift off cowl (key 6). Lift out diaphragm assembly (keys 7, 16 and 17).
3. Disassemble diaphragm assembly by removing diaphragm screw (key 7) from pressure plate (key 16).

### Note

**This step is not necessary if installing a new diaphragm assembly (included in repair kit).**

4. Remove blind flange bolts (key 23) and take off blind flange (key 14). Remove screen (key 20) and gasket (key 13).
5. Hold the pusher plate (key 8) and remove stem nuts (key 22). Lift out stem assembly (keys 8 and 19) and valve spring (key 9). The disk (key 21) will drop off. If the disk is not easily removed from the stem, or the stem does not easily move in the bushing (key 10) is difficult to remove, inspect stem, seat ring (key 11) and disk carefully for notches, scratches or bending.
6. Remove the seat ring (key 11) from the pilot body (key 12) using a socket wrench. Do not remove the seat ring unless replacing the stem assembly (keys 8 and 19) and disk (key 21).

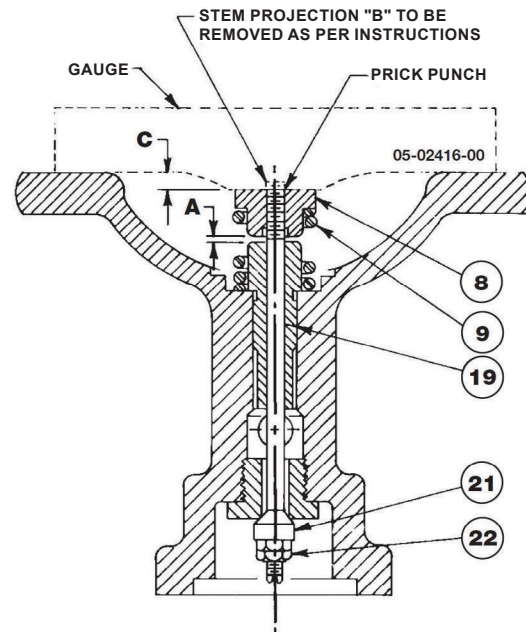

Figure 3. Travel Setting

## Inspection

1. Examine the seat ring (key 11) and disk (key 21) sealing surfaces for nicks or other signs of damage by pipeline debris. Slight imperfections may be removed by lapping the surfaces. Otherwise, replace the seat ring and disk.
2. Examine the stem (key 19) for a build-up of pipeline contaminants or erosion. Remove any build-up with a wire brush and polish with a very fine crocus cloth. Work carefully to avoid bending the stem.
3. Inspect the pilot body (key 12) and its ports for corrosion. Some rust is normal, but if corrosion debris is readily separated from the body, clean body with wire brush and remove debris.

## Lapping Operations

Lap sparingly using 500 grit lapping compound and light pressure. Heavy grinding may cause galling, wide sealing surfaces and a groove disk, all of which tend to produce leakage.

Lapping may be done using a socket wrench to rotate the stem and disk assembly back and forth against the seat for 30 seconds or so. After the sealing surfaces are lapped in, disassemble and clean all parts.

# D Series

## Seat, Disk and Stem Replacement

1. Clean the body threads of old sealing compound using a wire brush.
2. Apply new sealing compound (High-pressure, high-temperature sealant) to the shoulder of the seat ring (key 11). Let stand until tacky before installing in pilot body (key 12).
3. Secure disk (key 21) to stem (key 19) with a stem nut (key 22). Apply lapping compound to the disk and insert this assembly into the pilot body (omit the valve spring C).
4. Use a socket and extender to lap in the disk (key 21) to seat joint. See Lapping Operations for more information.
5. Screw pusher plate (key 8) onto the stem. Holding the disk firmly against its seat, adjust the pusher plate so that dimension C = 11/64 in. / 4.37 mm. A gauge (part number 05-02416-00) is supplied with each repair kit. Be careful not to disturb the pusher plate adjustment, use a prick punch to notch the stem threads above the pusher plate so that the pusher plate will not rotate freely. Work carefully to avoid bending the stem. The valve travel is now set.
6. Remove the stem nut and lift the stem assembly (keys 19 and 8) out of the top of the pilot. Grind off the stem Projection B flush with the upper surface of the pusher plate. This can be done at the bench without removing the stem from the body as long as the grinder does not make contact with the mating surfaces of the pilot body.
7. Reinsert the stem into the pilot body. Install disk (key 21) and a stem nut (key 22).
8. Check that the valve travel A = 3/64 in. / 1.19 mm. This need not be exact. Stem (key 19) should move smoothly. Binding indicates a bent stem.
9. Remove the stem nut (key 22) and disk (key 21); withdraw stem (key 19). Install stem with valve spring (key 19), disk and both stem nuts.

### Reassembly

1. If the seat ring (key 11), disk (key 21) and stem (key 19) were not replaced, reinstall the seat ring first, then slide the valve spring (key 9) over the bushing (key 10) and slide the stem back into place. If they were replaced, skip to step 3.
2. Install the seat ring (key 11) and stem nuts (key 22) one at a time while holding the pusher plate (key 8) with a socket.

Table 2. Number of Diaphragm Disk

ADJUSTING SPRING RANGE		DIAPHRAGM DISK
psig	bar	
0 to 8	0 to 0.55	1
3 to 20	0.21 to 1.38	2
5 to 50	0.35 to 3.45	2
10 to 100	0.69 to 6.89	2
20 to 150	1.38 to 10.3	3

3. Install the screen (key 20) and gasket (key 13). Using the blind flange bolts (key 23), reinstall blind flange (key 14).

### Note

**When replacing gaskets, be sure that any serrated sealing surfaces are cleaned of old gasket material.**

4. Assemble the diaphragm assembly (keys 7, 16 and 17) by sandwiching the diaphragms (key 17) between the pressure plate (key 16) (flat side against diaphragm) and the diaphragm screw (key 7). The number of diaphragm disks depends on the adjusting spring range. See Table 2.
5. Apply sealing compound (High-pressure, high-temperature sealant) to the shoulder of the diaphragm screw. Apply sealing compound to the diaphragm flange of the pilot body for steel body pilots only.
6. Put the diaphragm assembly into place (pressure plate up). Center the assembly and install the cowl (key 6). Install four diaphragm bolts or studs (key 18) and diaphragm nuts (key 15) equally around the cowl to ensure the diaphragm assembly is centered. Install the rest of the diaphragm nuts, bolts and/or studs and tighten in an opposing pattern.
7. Install the spring button (key 5), adjusting spring (key 4), spring yoke (key 2) and adjusting nuts (key 1).

## Parts Ordering

When ordering parts, it is essential that the pilot type, service and serial number be stated.

Select part by item number, but order by part number. Specify complete part number when ordering.

## Parts List

Repair Parts Kit (See Table 3)

D Series and Options Parts List (See Tables 4 to 7)

**Table 3. Repair Parts Kit**

REPAIR KIT	MATERIAL	PART NUMBER
Repair Kit - Hard	Cast iron Pilot	WAL07-04164-00
Repair Kit - Hard	Steel Pilot	WAL08-10375-00
Repair Kit - Soft	Cast iron Pilot	WAL08-08556-00
Repair Kit - Soft	Steel Pilot	WAL08-10379-00

**Table 4. Types D and D5 Series Parts List**

KEY	PART NAME	MATERIAL	PART NUMBER	QUANTITY	REMARKS
1	Adjusting Nut	Steel	WAL05-02874-00	2	----
2	Spring Yoke	Iron	WAL05-06183-00	1	----
3	Standard	Steel	WAL04-05219-00	2	----
4	Adjusting Spring	Steel	See Table 1	1	----
5	Spring Button	Steel	WAL04-01040-00	1	----
6	Cowl	Cast iron	WAL04-01508-00	1	Cast iron Body
	Cowl	Steel	WAL04-1592-00	1	Steel Body
7 <sup>(1)</sup>	Diaphragm Screw	Steel	WAL04-04822-00	1	----
8 <sup>(1)</sup>	Pusher Plate	Steel	WAL04-03718-00	1	----
9 <sup>(1)</sup>	Valve Spring	Inconel®	WAL05-04985-00	1	----
10	Bushing	Stainless steel	WAL04-01080-00	1	----
11 <sup>(1)</sup>	Seat Ring	Seco Metal	WAL04-04057-90	1	----
12	Body, Bushing, Plug	Cast iron	WAL07-03514-00	1	----
	Body, Bushing, Plug	Steel	WAL07-04267-02	1	----
13*	Gasket	Blugard	WAL05-02378-01	1	Cast iron Body
	Gasket	Flexitalic	WAL05-11718-00	1	Steel Body
14	Blind Flange	Cast iron	WAL04-02151-00	1	----
	Blind Flange	Steel	WAL04-11678-00	1	----
15	Diaphragm Nut	Steel	WAL05-02871-00	12	Cast iron Body
	Diaphragm Nut	Steel	WAL05-02845-00	24	Steel Body
16 <sup>(1)</sup>	Pressure Plate	Steel	WAL04-06979-00	1	----
17 <sup>(1)</sup>	Diaphragm	Stainless steel	WAL04-01623-00	3	----
18	Diaphragm Bolt	Steel	WAL05-04764-00	12	Cast iron Body
	Diaphragm Stud	Steel	WAL05-05490-00	12	Steel Body
19 <sup>(1)</sup>	Stem	Stainless steel	WAL04-05229-00	1	----
20 <sup>(1)</sup>	Screen	Stainless steel	WAL04-04700-00	1	Steam Service
	Screen	Stainless steel	WAL04-04701-00	1	Water Service
21 <sup>(1)</sup>	Disk	Seco Metal	WAL04-01772-90	1	----
22 <sup>(1)</sup>	Stem Nut	Steel	WAL05-02888-00	2	Steam Service
	Stem Nut	Brass	WAL05-02886-00	2	Water Service
23	Blind Flange Bolt	Steel	WAL05-04803-00	4	Cast iron Body
	Blind Flange Bolt	Steel	WAL05-11719-00	4	Steel Body

1. This part is furnished in Repair Kit.

# D Series

**Table 5. D Series Options Parts List**

KEY	PART NAME	MATERIAL	PART NUMBER	QUANTITY	REMARKS
<b>Locking Device</b>					
35	Padlock	Brass	WAL05-03204-00	1	----
36	Lock Bar	Steel	WAL04-00436-00	1	----
37	Spring Yoke Assembly	Iron	WAL07-43507-00	1	----
<b>Wall Bracket</b>					
15	Diaphragm Nut	Steel	WAL05-02871-00	1	Iron Body
	Diaphragm Nut	Steel	WAL05-02845-00	4	Steel Body
38	Wall Bracket	Cast iron	WAL04-01029-00	4	----
39	Diaphragm Bolt	Steel	WAL05-04766-00	4	Iron Body
	Diaphragm Stud	Steel	WAL05-05462-00	8	Steel Body
<b>Composition Disk</b>					
25 <sup>(1)</sup>	Disk Assembly	Brass	WAL07-53512-00	1	----
26 <sup>(1)</sup>	Stem	Stainless steel	WAL04-05381-00	1	----
27 <sup>(1)</sup>	Seat Ring	Stainless steel	WAL04-04060-00	1	----
<b>Enclosed Spring Chamber</b>					
28	Adjusting Screw	Steel	WAL05-04860-00	1	----
29	Locknut	Steel	WAL05-02942-00	1	----
30	Spring Chamber	Iron	WAL04-01393-00	1	----
	Spring Chamber	Bronze	WAL04-01395-00	1	----
	Spring Chamber	Steel	WAL04-01394-00	1	----
	Enclosed Spring Chamber Kit	Cast iron	WAL08-01868-00		----
<b>Adjusting Wheel</b>					
31	Handwheel	Aluminum	WAL04-12985-01	1	----
32	Adjusting Screw	Steel	WAL04-04752-02	1	----
33	Locknut	Steel	WAL05-02942-00	1	----
34	Yoke	Cast iron	WAL04-06170-00	1	Iron Body
	Yoke	Ductile iron	WAL04-06167-02	1	Steel Body
	Handwheel Kit	Cast iron	WAL08-01867-00		----
<b>Vacuum Spring Assembly</b>					
40	Floating Plate	Iron	WAL04-03710-00	1	----
41	Vacuum Spring	302 Stainless steel	WAL05-05055-00	1	----
42	Valve Spring	Inconel®	WAL05-09353-00	1	----

1. This part is furnished in Repair Kit.



**Table 6. Type D120 Pilot (Figure 6)**

KEY	PART NAME	MATERIAL	PART NUMBER	REMARKS
1	Adjusting Screw	Steel	WAL4-04760-0	----
2	Locknut	Steel	WAL5-02877-0	----
3	Standard Nut	Steel	WAL5-02877-0	----
4	Spring Yoke	Cast iron	WAL4-06177-0	----
5	Guide Stud	Stainless steel	WAL4-05419-0	----
6	Upper Spring Button	Steel	WAL4-01078-0	----
7	Adjustment Spring, 5 to 25 psi / 0.35 to 1.72 bar	Steel	WAL5-05016-0	Use 2 Diaphragm
	Adjustment Spring, 10 to 75 psi / 0.69 to 5.17 bar	Steel	WAL5-05028-0	Use 2 Diaphragm
	Adjustment Spring, 40 to 150 psi / 2.76 to 10.3 bar	Alloy steel	WAL5-05030-0	Use 3 Diaphragm
8	Standard	Steel	WAL5-05200-0	----
9	Lower Spring Button	Steel	WAL4-01041-0	----
10	Diaphragm Nut	Steel	WAL5-02872-0	Note 1
	Diaphragm Nut	Steel	WAL5-02848-0	Note 2
11	Cowl	Cast iron	WAL4-01513-0	----
	Cowl	Steel	WAL4-01514-0	----
12	Diaphragm	Stainless steel	WAL4-01659-0	A, B See item 7
13	Diaphragm Bolt	Steel	WAL5-04770-0	Note 1
	Diaphragm Stud	Steel	WAL5-05480-0	Note 2
14	Bushing	Stainless steel	WAL4-01132-0	See item 16
15	Stem	Stainless steel	WAL4-05305-1	B
16	Body and Bushing	Cast iron	WAL8-09159-0	----
	Body and Bushing	Steel	WAL8-09160-1	----
17	Screen - Steam	Monel®	WAL4-04700-0	B
18	Pressure Plate	Cast iron	WAL4-03599-0	B
19	Diaphragm Screw	Steel	WAL4-04822-0	B
20	Pusher Plate	Steel	WAL4-03717-0	B
21	Valve Spring	Inconel®	WAL5-04985-0	A, B
22	Seat Ring	Stainless steel	WAL4-04062-0	B
23	Disk	Stainless steel	WAL4-07283-1	B
24	Stem Nut	Steel	WAL5-02891-0	B
25	Gasket	Asbestos	WAL5-02378-0	A, B Note 1
	Gasket	Flexitalic	WAL5-11718-0	A, B Note 2
26	Blind Flange	Cast iron	WAL4-02151-0	----
	Blind Flange	Steel	WAL4-11678-0	----
27	Blind Flange Bolt	Steel	WAL5-04803-0	Note 1
	Blind Flange Bolt	Steel	WAL5-11719-0	Note 2
28	Pipe Plug, 1/4 NPT	Steel	WAL4-03772-0	Not shown
<b>Wall Bracket</b>				
29	Wall Bracket	Iron	WAL4-01028-0	----
30	Diaphragm Bolt	Steel	WAL5-04781-0	----
10	Diaphragm Nut	Steel	WAL5-02872-0	----
A - Recommended Spare Parts B - Furnished in Repair Kit: WAL8-09154-0 Note 1 WAL8-10356-0 Note 2 Note 1: Applies to Iron Body Pilots Note 2: Applies to Steel Body Pilots				

Inconel® and Monel® are marks owned by Special Metals Corporation.

# D Series

**Table 7. Type D2 Pilot Parts List (Figure 7)**

KEY	PART NAME	MATERIAL	PART NUMBER	REMARKS
1	Adjusting Screw	Steel	WAL4-04760-0	----
2	Adjusting Screw Locknut	Steel	WAL5-02953-0	----
3	Guide Stud	Stainless steel	WAL4-05419-0	----
4	Standard Nut	Steel	WAL5-02874-0	----
5	Spring Yoke	Cast iron	WAL4-06179-0	----
6	Upper Spring Button	Steel	WAL4-01078-0	----
7	Standard	Steel	WAL4-05213-0	----
8	Adjusting Spring	Aluminum steel	WAL5-04990-0	----
9	Lower Spring Button	Steel	WAL4-01041-0	----
10	Diaphragm Nut	Steel	WAL5-02871-0	Note 1
	Diaphragm Nut	Steel	WAL5-02845-0	Note 2
11	Pressure Plate	Steel	WAL4-03679-0	B
12	Body and Bushing	Iron	WAL7-03514-0	----
	Body and Bushing	Bronze	WAL8-04265-0	----
	Body and Bushing	Steel	WAL7-04267-2	Screwed
	Body and Bushing	Steel	WAL8-09518-2	Flanged Inlet
	Body and Bushing	Steel	WAL8-09517-2	Secoweld Screwed
13	Diaphragm Bolt	Steel	WAL5-04764-0	Note 1
	Diaphragm Stud	Steel	WAL5-05490-0	Note 2
14	Diaphragm	Stainless steel	WAL4-01623-0	A, B (3 per set)
15	Valve Spring	Inconel®	WAL5-04985-0	A, B
16	Bushing	Stainless steel	WAL4-01080-0	See item 12
17	Gasket	Asbestos	WAL5-02378-0	A, B, Note 1
	Gasket	Flexitalic	WAL5-11718-0	A, B, Note 2
18	Blind Flange	Iron	WAL4-02151-0	----
	Blind Flange	Bronze	WAL4-02153-0	----
	Blind Flange	Steel	WAL4-11678-0	----
19	Blind Flange Bolt	Steel	WAL5-04803-0	Note 1
	Blind Flange Bolt	Steel	WAL5-11719-0	Note 2
20	Cowl	Iron	WAL4-01505-0	----
	Cowl	Steel	WAL4-01591-0	----
21	Diaphragm Screw	Steel	WAL4-04822-0	B
22	Pusher Plate	Steel	WAL4-03718-0	B
23	Stem	Stainless steel	WAL4-05229-0	B
24	Seat Ring	Stainless steel	WAL4-04057-0	B
25	Disk	Stainless steel	WAL4-01772-0	B
26	Stem Nut	Steel	WAL5-02888-0	B
27	Screen - Water	Monel®	WAL4-04701-0	----
	Screen - Steam	Monel®	WAL4-04700-0	B
28	Pipe Plug, 1/8 NPT	Steel	WAL4-03769-0	Not Shown
	Pipe Plug, 1/8 NPT	Brass	WAL4-03770-0	Not Shown

A - Recommended Spare Parts  
 B - These parts furnished in Repair Kit (Steam screen):  
 Stainless steel Disk: Cast iron and Bronze (WAL8-09157-0), Carbon steel (WAL8-10357-0)  
 Composite Disk: Cast iron and Bronze (WAL8-09158-0), Carbon steel (WAL8-10380-0)  
 Note 1: Applies to Iron and Bronze Body Pilots  
 Note 2: Applies to Steel Body Pilots  
 Use Pilot Setting instructions WAL9-98165-0

- continued -

Inconel® and Monel® are marks owned by Special Metals Corporation.

**Table 7. Type D2 Pilot Parts List (Figure 7) (continued)**

KEY	PART NAME	MATERIAL	PART NUMBER	REMARKS
<b>Enclosed Spring Chamber</b>				
29	Spring Chamber	Steel	WAL7-40529-0	----
<b>Adjusting Handle</b>				
30	Handle and Hub Assembly	Steel	WAL8-09774-0	----
31	Adjusting Stud Spacer	Brass	WAL4-05600-0	----
32	Thrust Bearing	Steel	WAL5-00552-0	----
33	Guide Standard Locknut	Steel	WAL5-03016-0	----
34	Cross Bar	Steel	WAL4-00434-0	----
35	Guide Standard Spacer	Brass	WAL4-04936-0	----
36	Support Standard Nut	Steel	WAL5-02942-0	----
37	Adjusting Stud Assembly	----	WAL7-40550-0	----
38	Spring Yoke	Cast iron	WAL4-06173-0	----
39	Support Standard	Steel	WAL4-05223-0	----
40	Guide Standards	Steel	WAL4-05221-0	----
<b>Wall Bracket</b>				
41	Wall Bracket	Cast iron	WAL4-01029-0	----
42	Diaphragm Bolt	Steel	WAL5-04766-0	Note 1
10	Diaphragm Stud	Steel	WAL5-05462-0	Note 2
	Diaphragm Nut	Steel	WAL5-02871-0	Note 1
	Diaphragm Nut	Steel	WAL5-02845-0	Note 2
<b>Flanged Inlet</b>				
44	Gasket	Steel Asbestos	WAL5-02370-0	----
45	Flange Assembly - Female	Steel	WAL7-43516-0	See item 12
46	Flange Assembly - Male	Steel	WAL7-40535-0	----
13	Stud	Steel	WAL5-05490-0	----
10	Nut	Steel	WAL5-02845-0	----
<b>Composition Disk</b>				
47	Stem	Stainless steel	WAL4-05381-0	B
48	Seat Ring	Stainless steel	WAL4-04060-0	B
49	Composite Disk Assembly	Brass	WAL7-53512-0	B
<p>A - Recommended Spare Parts            B - These parts furnished in Repair Kit (Steam screen):                Stainless steel Disk: Cast iron and Bronze (WAL8-09157-0), Carbon steel (WAL8-10357-0)                Composite Disk: Cast iron and Bronze (WAL8-09158-0), Carbon steel (WAL8-10380-0)            Note 1: Applies to Iron and Bronze Body Pilots            Note 2: Applies to Steel Body Pilots            Use Pilot Setting instructions WAL9-98165-0</p>				

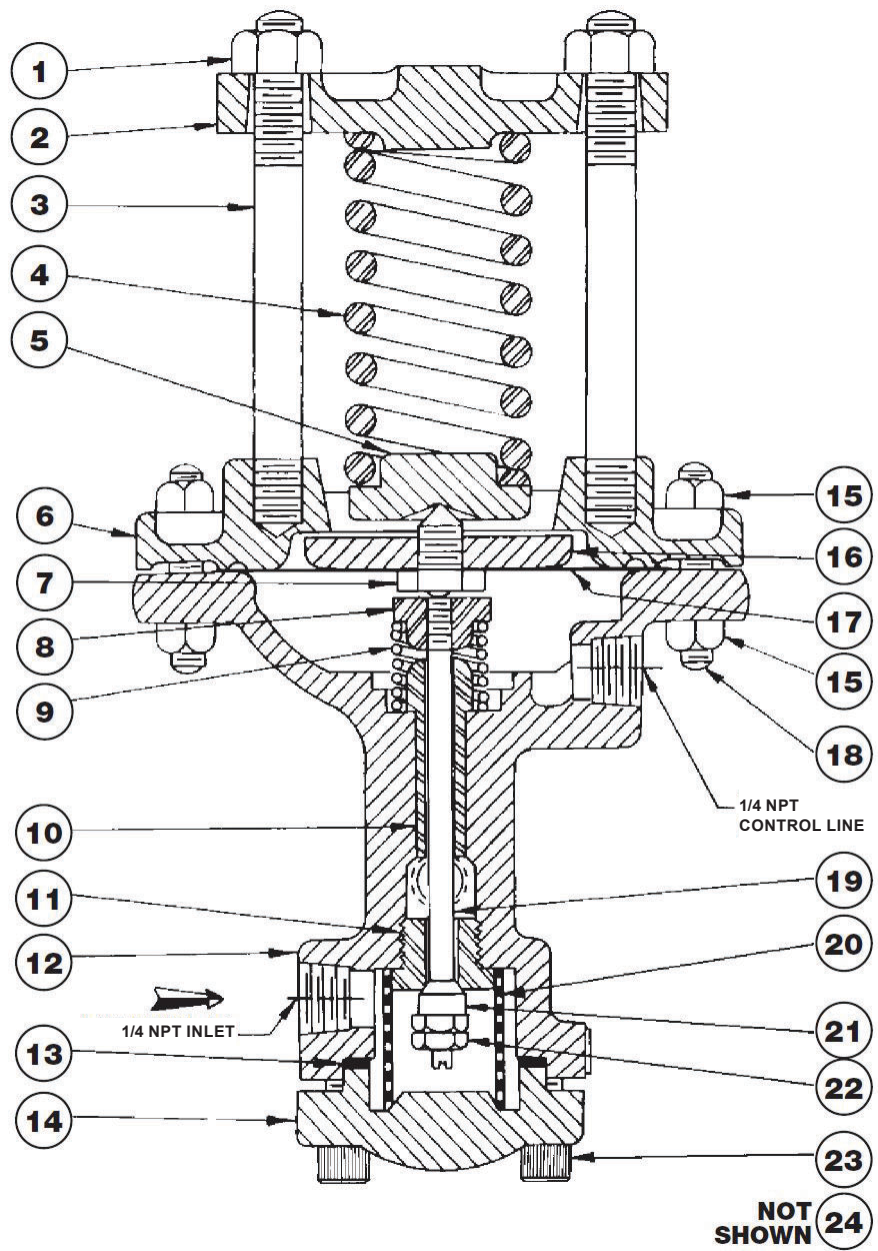

Figure 4. Type D Pilot Assembly

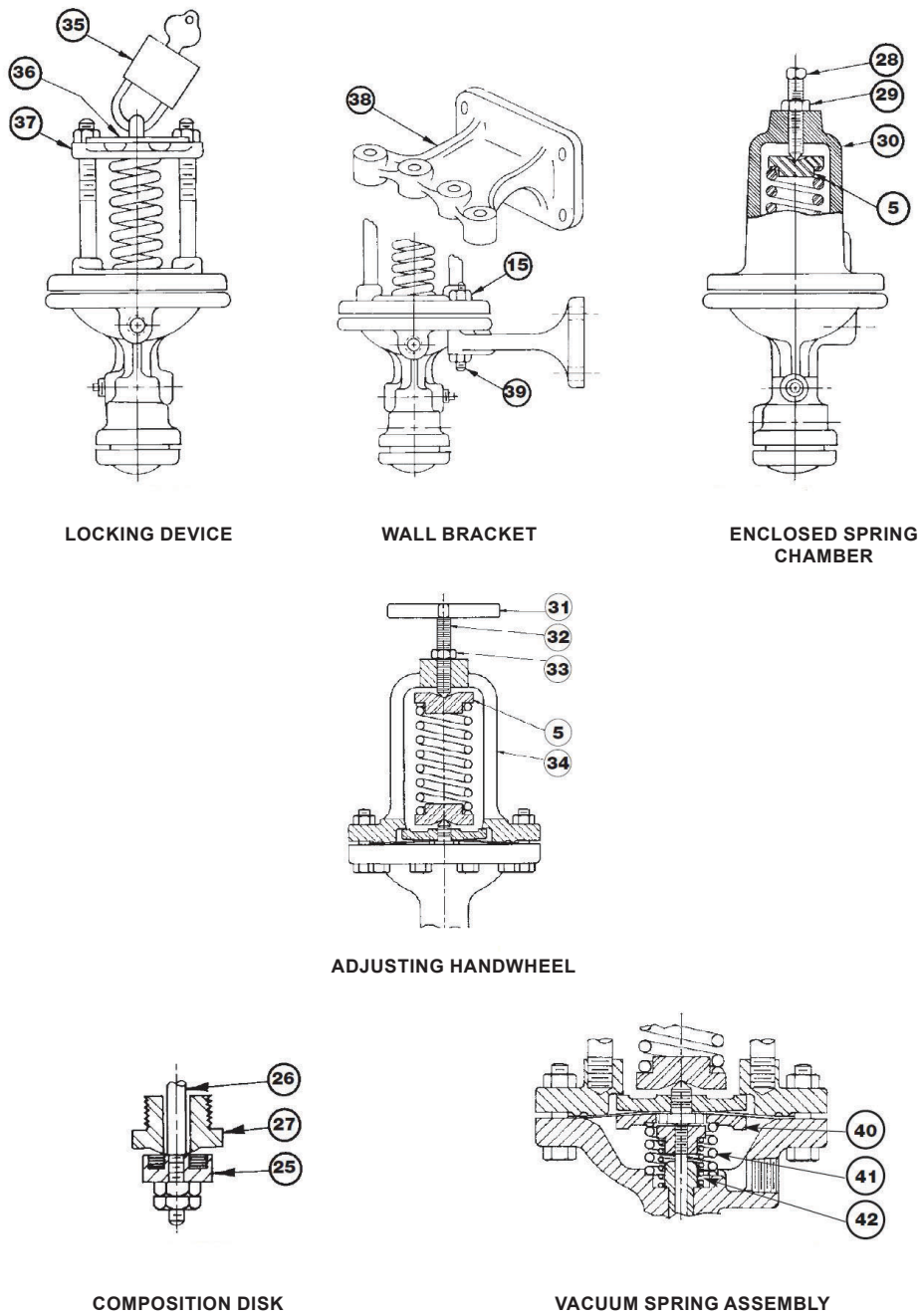
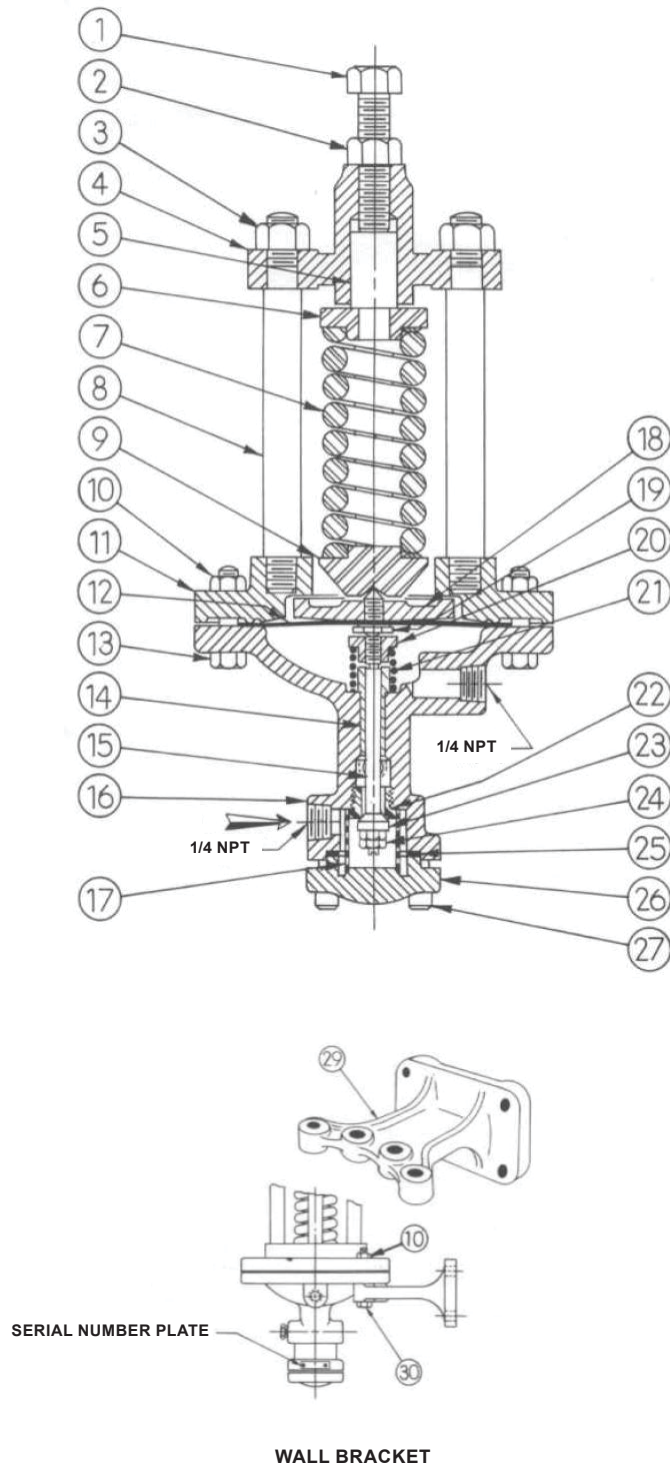
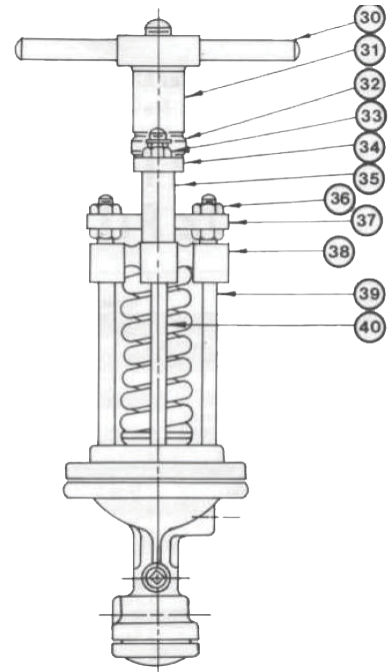
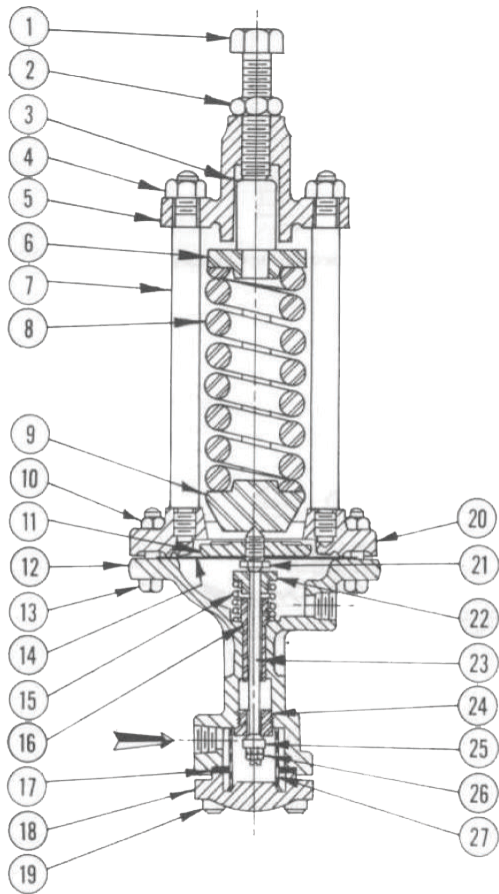

Figure 5. D Series Options Assembly



**Figure 6. Type D120 Pilot Assembly**



ADJUSTING HANDLE

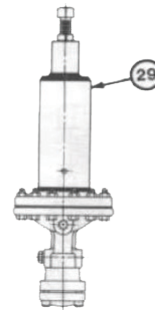

ENCLOSED SPRING CHAMBER

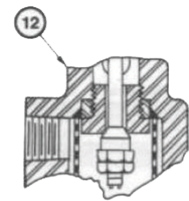

ALTERNATE:  
SECOWELD CONSTRUCTIONS

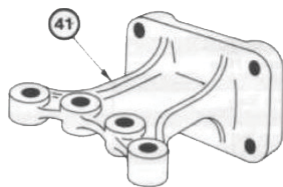

WALL BRACKET

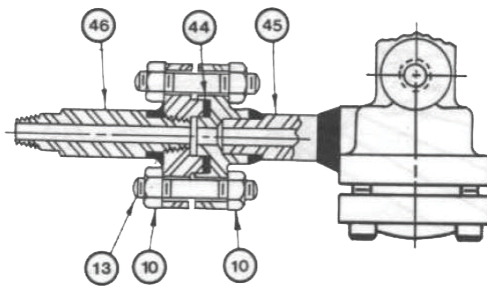
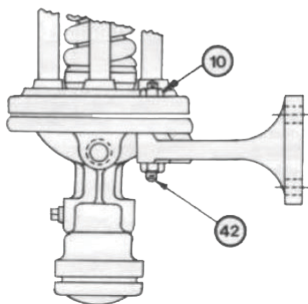

FLANGED INLET

Figure 7. Type D2 Pilot Assembly

# D Series

---

 [SpenceValve.com](https://www.SpenceValve.com)

## Emerson Automation Solutions

### Americas

McKinney, Texas 75070 USA  
T +1 800 558 5853  
+1 972 548 3574

### Europe

Bologna 40013, Italy  
T +39 051 419 0611

### Asia Pacific

Singapore 128461, Singapore  
T +65 6777 8211

### Middle East and Africa

Dubai, United Arab Emirates  
T +971 4 811 8100

VCIMD-14966-EN © 2021, 2023 Emerson Electric Co. All rights reserved 06/23. Spence is a mark owned by one of the companies in the Emerson Automation Solutions business unit of Emerson Electric Co. The Emerson logo is a trademark and service mark of Emerson Electric Co. All other marks are property of their prospective owners.

The contents of this publication are presented for informational purposes only, and while every effort has been made to ensure their accuracy, they are not to be construed as warranties or guarantees, express or implied, regarding the products or services described herein or their use or applicability. All sales are governed by our terms and conditions, which are available upon request. We reserve the right to modify or improve the designs or specifications of such products at any time without notice.

Emerson Electric Co. does not assume responsibility for the selection, use or maintenance of any product. Responsibility for proper selection, use and maintenance of any Emerson Electric Co. product remains solely with the purchaser.

