



Atmospheric Low NOx Commercial Gas Water Heaters

Ideal for Large Residences, Small Restaurants, Apartment Buildings, Office Complexes, Dairy Barns, Salons, Barbershops and Many Other Facilities

■ Five-Year Limited Tank/Heat Exchanger Warranty
– THE INDUSTRY'S FINEST

ezFIT Features:

- 135,000 to 199,000 BTU/hr
- 75/80/100 gallon capacities
- Low NOx certified to not exceed 40ng/J
- Natural gas or propane burner
- 120°F to 180°F adjustable electronic thermostat
- Electronic ignition
- Automatic damper
- Water jet sediment reduction side inlet
- Clean out port
- Optional leg extension kit lifts water heater to NSF-5 standard
- Ecomate® insulation
- 26 to 32-inches wide

Turboflue® High Performance Heat Exchanger:

- Patented helical-fin multi-stage design
- Superior heat conduction and fuel efficiency

Made in the USA



ezFIT *EASILY REPLACES ANY
COMPETITIVE HEATER*

BUILT LIKE A BOCK

BOCK *EZFIT* EASILY REPLACES ANY COMPETITIVE HEATER

This product is available from:

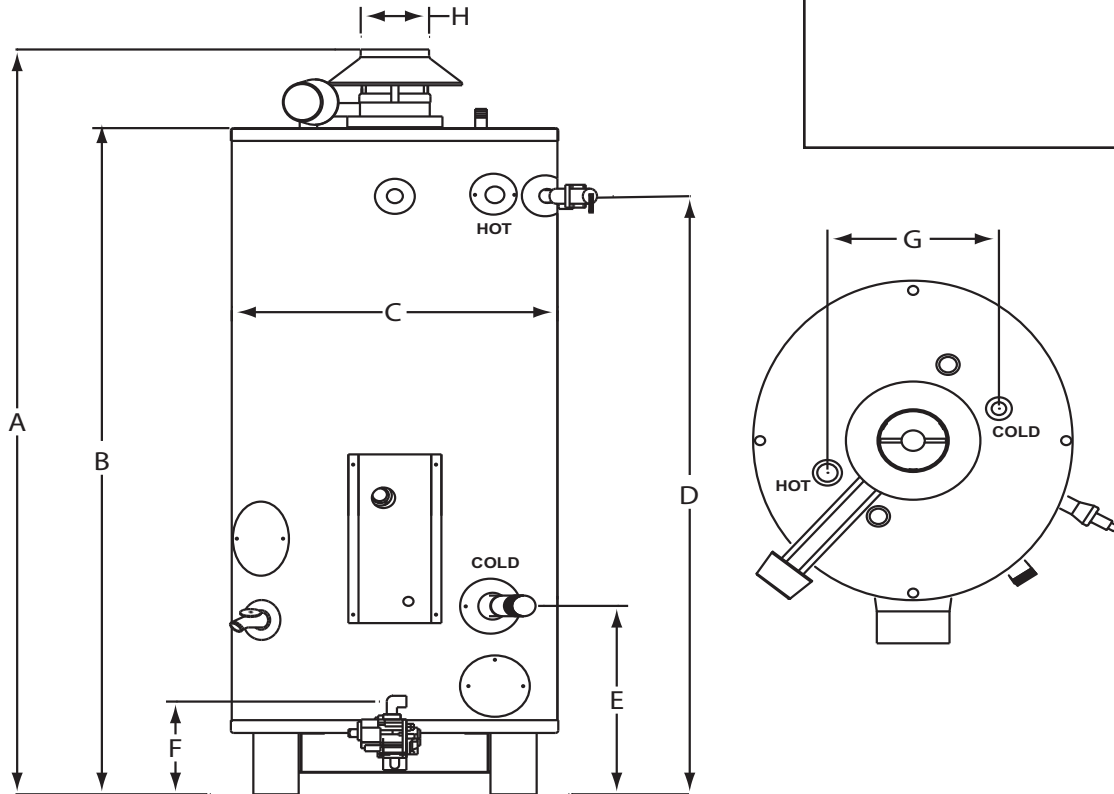

Model	Storage GAL (L)	Rated Input BTU/HR (kW)	Recovery @ 100°F Rise GAL/HR (L/HR)	1st Hr. Del. @ 100°F Rise GAL (L)	Dimensions in Inches (cm)								Aux. Conn. Dia. NPT	Inlet Conn. Dia. NPT	Outlet Conn. Dia. NPT	Gas Conn. Dia. NPT	Shipping Weight LBS (kg)
					A	B	C	D	E	F	G	H					
EZ75-135N	67 (253.62)	135,000 (39.56)	130 (492.10)	183 (692.73)	73.25 (186.06)	65.50 (166.37)	26.00 (66.04)	58.25 (147.96)	20.00 (50.80)	9.00 (22.86)	16.00 (40.64)	6.00 (15.24)	1.50	1.50	1.50	0.75*	410 (185.97)
EZ80-156N	80 (302.83)	156,000 (45.72)	150 (567.81)	214 (810.08)	73.25 (186.06)	65.50 (166.37)	26.00 (66.04)	58.50 (148.59)	18.00 (45.72)	9.00 (22.86)	16.00 (40.64)	6.00 (15.24)	1.50	1.50	1.50	0.75*	440 (199.58)
EZ80-199N	80 (302.83)	199,000 (58.32)	191 (723.01)	255 (965.28)	73.00 (185.42)	65.25 (165.74)	28.00 (71.12)	58.50 (148.59)	18.00 (45.72)	9.00 (22.86)	16.00 (40.64)	6.00 (15.24)	1.50	1.50	1.50	0.75*	500 (266.80)
EZ100-199N	100 (378.54)	199,000 (58.32)	191 (723.01)	271 (1,025.85)	72.75 (184.79)	63.00 (160.02)	32.00 (81.28)	54.75 (139.07)	18.00 (45.72)	9.00 (22.86)	19.00 (48.26)	6.00 (15.24)	1.50	1.50	2.00	0.75*	655 (297.10)

For LP models change suffix "N" to "LP"

*LP Gas valve - .50 NPT

Working Pressure: 150 psi (1034 kPa)

Test Pressure: 300 psi (2068 kPa)

Standard Voltage required: 120V, 60Hz, 1P

For natural gas: manifold pressure = 3.5" w.c. (0.87 kPa); Inlet pressure range = 5 - 14" w.c. (1.25-3.49 kPa)

For propane gas: manifold pressure = 10" w.c. (2.49 kPa); Inlet pressure range = 12 - 14" w.c. (2.99-3.49 kPa)

T&P valve factory installed

All Bock products meet or exceed current ASHRAE standards.

These products are design certified by UL (Underwriters Laboratories) and meet ANSI Z21.10.3/CSA 4.3 requirements for operation up to 180°F (82°C).

Approved for use as an automatic storage water heater.

Warning: Do not install on combustible flooring. Installation should be in accordance with all national and/or local codes.

In the absence of local codes, refer to NFPA 54 or CSA B149.1.

Caution: The recommended maximum hot water temperature setting for normal residential use is 120°F (49°C). Bock recommends a tempering valve or anti-scald valve be installed and used according to the manufacturer's directions to prevent scalding.



(on selected models)

